

THE POST OFFICE ELECTRICAL ENGINEERS' JOURNAL

VOL. 30

APRIL, 1937

PART 1

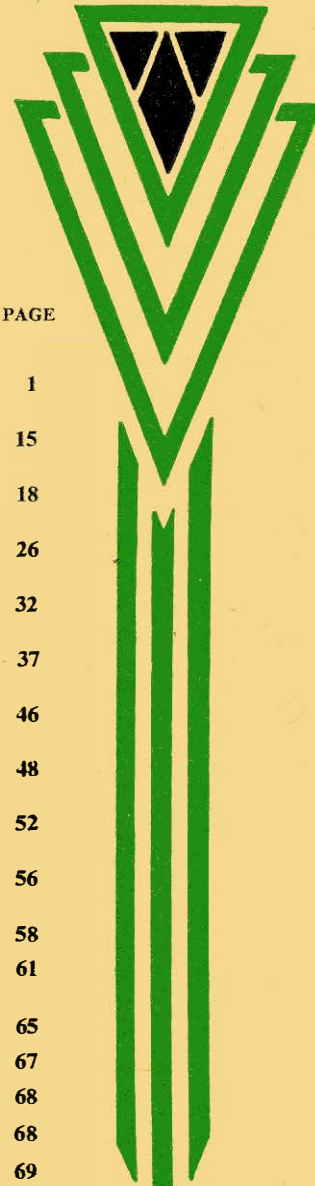
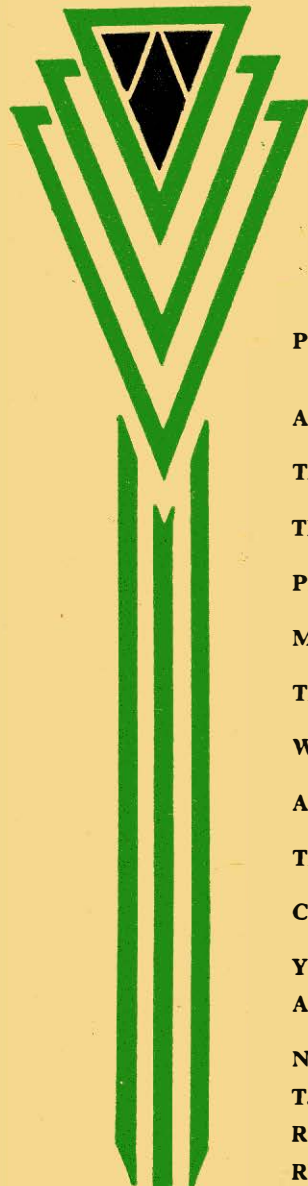

CONTENTS

	PAGE
PRESENT TENDENCIES OF POWER DEVELOPMENT AND THEIR REPERCUSSIONS UPON TELECOMMUNICATION SYSTEMS—P. B. Frost, B.Sc.(Eng.), M.I.E.E.	1
A NOVEL SYSTEM OF DIPLEX TRANSMISSION—A. J. A. Gracie, B.Sc., A.M.I.E.E.	15
THE DEVELOPMENT OF STAMP-SELLING MACHINES IN THE BRITISH POST OFFICE—J. H. Combridge, Graduate I.E.E.	18
THE C.T.O. INLAND PHONOGRAM AND TELEPHONE-TELEGRAM INSTALLATION—T. E. Hogg and J. Sharp	26
PROBLEMS INVOLVED IN THE PREPARATION OF A EUROPEAN TRUNK SWITCHING PLAN—A. C. Timmis, B.Sc., A.M.I.E.E.	32
MODERN DEVELOPMENTS IN TELEVISION Part I.—Transmission Systems—S. T. Stevens	37
THE VARIATION OF THE HOLDING TIMES OF TELEPHONE CALLS—E. D. Glazier, B.Sc.(Eng.)	46
WATERLOO BRIDGE—ALTERATION OF POST OFFICE PLANT—H. Whenmouth	48
A SIMPLE TRANSMISSION MEASURING EQUIPMENT—L. E. Ryall, Ph.D. (Eng.), A.M.I.E.E., and A. G. Burgess, A.M.I.R.E.	52
THE MAINTENANCE ASPECT OF OVERHEAD CONSTRUCTION WORK—R. C. C. Brown	56
CENTRALISED ROUTINER AND MAINTENANCE CONTROL IN AUTOMATIC EXCHANGES—A. E. Brogden	58
YOUNG PEOPLE'S TELEPHONE EXHIBITION—E. C. Baker	61
A ROUTE DISTANCE RECORDER—R. O. Boocock, B.Sc.(Eng.) and W. E. T. Andrews	65
NOTES AND COMMENTS	67
T. WALMSLEY, Ph.D., M.Inst.C.E., A.M.I.E.E., M.I.R.E.	68
R. M. CHAMNEY, B.Sc., Assoc.M.Inst.C.E., A.K.C.	68
RETIREMENT OF CAPT. J. G. HINES, M.I.E.E.	69
BOOK REVIEWS	69, 70, 75
THE INSTITUTION OF POST OFFICE ELECTRICAL ENGINEERS	71
JUNIOR SECTION NOTES	71
DISTRICT NOTES	73
STAFF CHANGES	76

Price 1/- net

THE INSTITUTION OF POST OFFICE ELECTRICAL ENGINEERS



CONTRACTORS TO THE GENERAL POST OFFICE.



TUNGSTONE THE INDEPENDENT BATTERY OF THE BRITISH EMPIRE.

Beware of the Tactics of Maker and Salesman

All of whom are handicapped in the strenuous efforts to disprove or if possible stop the successful progress and increasing Sales of the TUNGSTONE High-Pressure Machine Die-Cast Improved and Strengthened Planté Plate, which has created a World's Record

Self-Defence Against Unfair Comparison

The Salesman's Statement is *Not true*, that a Hand Poured Plate of any make or size or thickness is equal or comes anywhere near to the Metal Density, Weight, Tensile Strength, Rigidity or Long Life of a TUNGSTONE Plate of similar size and thickness.

Exceptional Plate Strength with Greater Density of Metal

TUNGSTONE'S originality of manufacture is the only reliable, mechanical method that guarantees the Heaviest and Strongest Planté Plate, with greater rigidity, exceptional tensile strength and density of Metal.

Nothing Counts except the Plate

All other Battery Makers in the World cast Planté Plates by hand pouring from Ladle using a metal, necessarily of very high temperature into a heated mould causing the metal to burn and lose its nature, producing a plate deficient in capacity and life.

No Plate Metal Poured by Hand

TUNGSTONE Original method by Machine High-Pressure at an extraordinary and yet regulated speed, injects a continuous stream of Metal at a low temperature into a Mould which cannot be distorted. A greater quantity of Metal is forced into any given Plate Area, and evenly distributed to the extreme limits of the Mould.

TUNGSTONE GUARANTEES NO DROSS CAST IN A POSITIVE PLATE

No oxidization or other Chemical changes can take place in the metal during the process of High-Pressure Die-Casting, as the Metal is NOT EXPOSED to the air. Other Makers by Hand Pouring cannot guarantee NO DROSS, as the Metal and Mould are CONTINUOUSLY EXPOSED TO THE AIR.

The Plate is the Nerve Centre of any Battery

TUNGSTONE ACCUMULATOR CO., LTD., St. Bride's House, Salisbury Square, E.C.4.

Telephone: CENTRAL 8156 (4 lines) & 8189.

Telegrams: "Typify, Fleet, London."

Cables: "Dilutum, London."

G.E.C.

TELEPHONES



Thousands upon thousands of Gecophones are in service all over the World, maintaining the reputation of the set as the acknowledged standard in modern telephones. They are used by Administrations demanding :—

Highest overall efficiency • Maximum suppression of sidetone • Advantages of self-contained instrument • Full tropical finish

For eight years no better telephone has been made

THE GENERAL ELECTRIC COMPANY LIMITED
TELEPHONE WORKS **COVENTRY**

Coventry 4111 (8 lines)

ENGLAND

“Springjack”, Coventry

Head Office : Magnet House, Kingsway, London, W.C.2

Temple Bar 8000 (75 lines)

“Electricity, Westcent” London

“Polyphase” London (Cables)

• **Branches and Agencies throughout the World**

TURNER DIFFERENTIAL MILLIAMMETERS G.P.O. No. 17 & No. 18

Meet the most exacting demands for balancing currents in multiplex telegraph circuits.

A quality product of outstanding merit

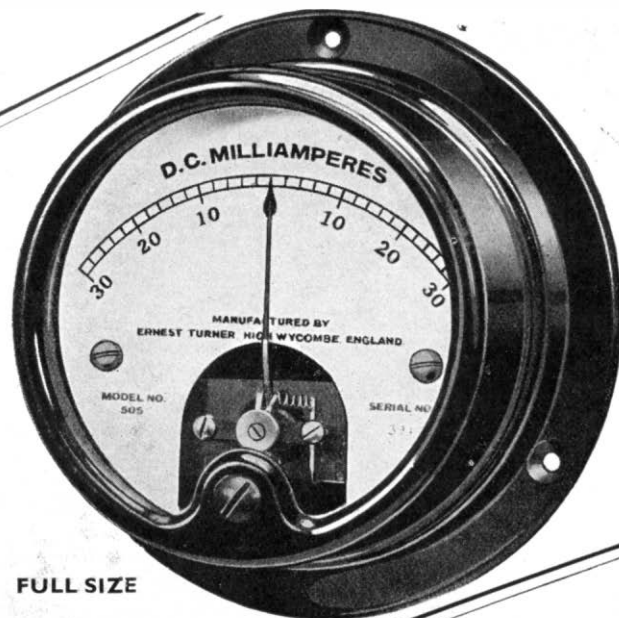

FULL SIZE

Also manufacturers of G.P.O. Detector No. 4, and a comprehensive line of instruments for precision electrical measurements.

ERNEST TURNER ELECTRICAL INSTRUMENTS, Ltd.

**CHILTERN WORKS,
55-73 TOTTERIDGE AVENUE,
HIGH WYCOMBE,**

BUCKS, ENGLAND

Telephone : High Wycombe 301.
Telegrams : Gorgeous, High Wycombe.

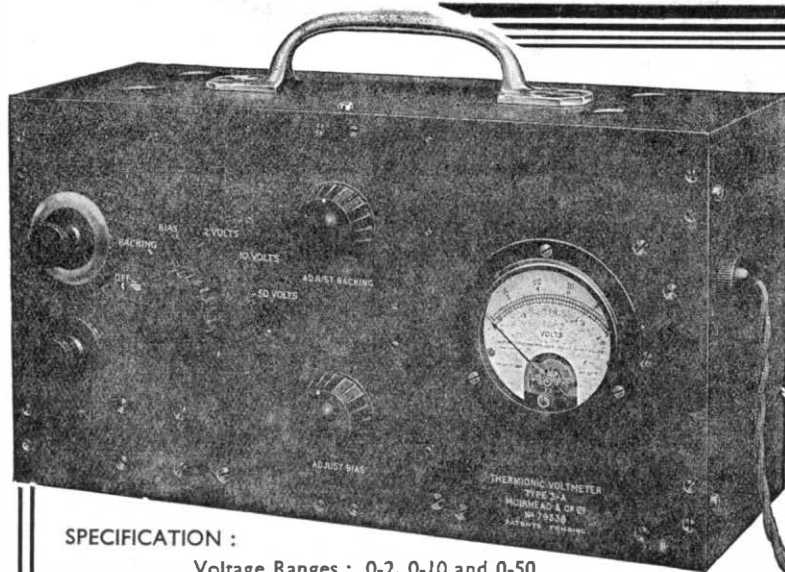

NEW THERMIONIC VOLTMETER

This instrument has been designed to provide an inexpensive high impedance voltmeter for use over a wide frequency range. It is mains operated, robust, and all scales are linear.

SPECIFICATION :

Voltage Ranges : 0-2, 0-10 and 0-50.
Input resistance : 2 megohms.

Input capacity : 9 micromicrofarads.
Dimensions of Container : 13" x 5" x 7" (high).

PRICE £17 . 10 . 0 (nett)

Similar Voltmeters can be supplied for rack mounting and also for battery operation.

MUIRHEAD & CO. LTD.
MAKERS OF PRECISION INSTRUMENTS FOR OVER 50 YEARS
ELMERS END
TELEPHONE

KENT
BECKENHAM 0041-2

A Self Contained

CATHODE RAY OSCILLOGRAPH

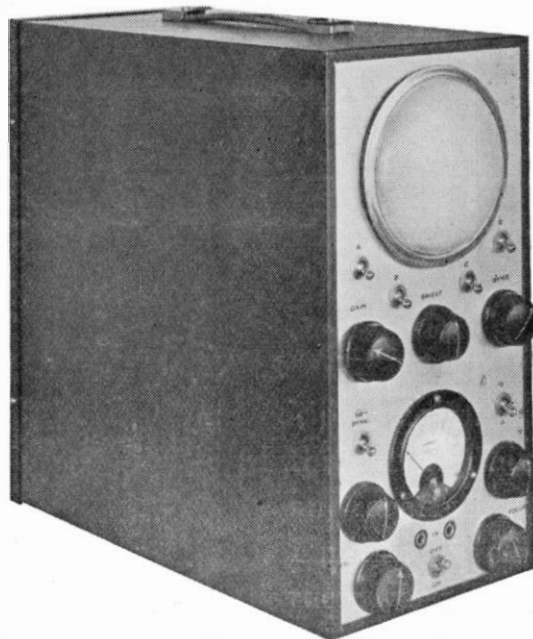

THE "Standard" 74320 Cathode Ray Oscilloscope is a portable, self-contained equipment operating from A.C. mains, and incorporating a linear time base suitable for viewing waves from 15 to 500,000 p.s. It includes a single stage amplifier, accurately linear for outputs covering the whole screen, the gain of which is 17 db. $\pm \frac{1}{2}$ db. (7 : 1) from 15 to 15,000 p.s.

A gas focused tube is used, necessitating only 300 or 700 volts on the anode.

*An example from the range of Cathode Ray
Oscilloscope Equipments manufactured by*

Standard Telephones and Cables Limited

NORTH WOOLWICH

LONDON, E.16

Telephone : Albert Dock 1401

LONDON TO OXFORD



SIEMENS CARRIER TYPE TRUNK TELEPHONE CABLE

Two cables each 63 miles in length, are laid in the same duct. 24 pairs, 40 lbs., air-space, star quad. Designed to operate up to 60 kilocycles per second.

manufactured & laid for the

BRITISH POST OFFICE

by

**SIEMENS BROTHERS & CO., LIMITED,
WOOLWICH, LONDON, S.E. 18**

Telephone : WOOLwich 1161

SIEMENS



"NEOPHONE"
**OPERATOR'S
 TELEPHONE**

The Neophone high-efficiency Operator's Telephone, incorporating the same basic principles which have proved so successful in the Neophone subscriber's telephone, was first introduced in 1933. Since then its ever increasing popularity is clearly indicated by the sales.

IN	1933	we sold	214
"	1934	" "	714
"	1935	" "	5,611
"	1936	" "	41,625



*Standardised by the
 BRITISH POST OFFICE
 and adopted by*

*many important overseas Telephone Administrations
 including Australia, New Zealand, South Africa,
 India, Canada, Egypt, etc.*

SIEMENS BROTHERS & CO., LIMITED,
 WOOLWICH, LONDON, S.E.18.

Telephone: WOOLWICH 2020.



Registered Trade Mark

THE SYMBOL OF PHOTOGRAPHIC SERVICE

For over half a century Ilford Limited have specialised in the manufacture of photographic materials for every industrial and scientific purpose.

The high quality of these products has won for them a world-wide reputation for unvarying consistency and they may be relied upon implicitly for use in every branch of research and record photography, oscillographic service as well as ordinance survey.

*Write for copy of booklet "Photography
as an aid to Scientific Work."*

ILFORD

PLATES — FILMS — PAPERS

MAKERS OF THE FAMOUS

Made in England by
ILFORD LIMITED,
ILFORD, LONDON

SELO & SELOchrome Roll Films



MODEL N°3A TAPE TELEPRINTER



MODEL N°5 PM.
MURRAY KEYBOARD PERFORATOR

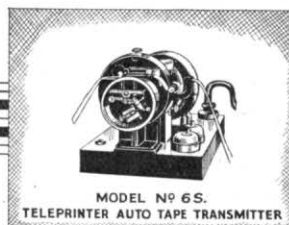

MODEL N° 6 S.
TELEPRINTER AUTO TAPE TRANSMITTER

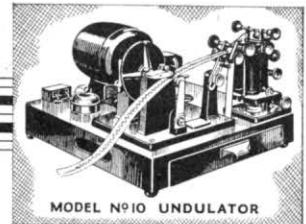

MODEL N°10 UNDULATOR

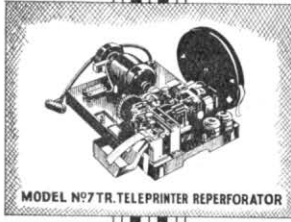

MODEL N°7 TR. TELEPRINTER REPERFORATOR

ILLUSTRATED are some of the instruments manufactured to provide printing telegraph machines to meet all modern communication requirements.



MODEL N° 9
MORSE KEYBOARD PERFORATOR

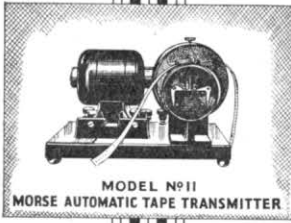

MODEL N°11
MORSE AUTOMATIC TAPE TRANSMITTER



MODEL N°7
PAGE TELEPRINTER
WITH COMMERCIAL TYPEWRITER KEYBOARD

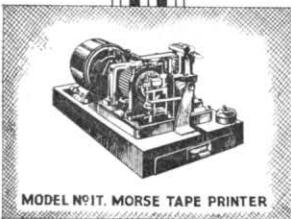

MODEL N°17. MORSE TAPE PRINTER



MODEL N°27 CREED RELAY (Cover removed)

CREED & CO. L^{TD.}

Telephone :—
Croydon 2121

Telegraph House
CROYDON

Telex :—
Croydon Telex 1082

NO INCREASE IN PRICES

Increased production to cope with the rapidly increasing demands of our customers has enabled us to reduce manufacturing costs, thus counterbalancing the increased prices of raw materials for "BERCO" RESISTANCES. We hope that your continued patronage will enable us to continue this policy.

Write for our latest illustrated Catalogue.

BERCO

Advt. of

**BRITISH ELECTRIC
RESISTANCE CO., LTD.**

Contractors to H.M. Admiralty, War Office, Air Ministry, Post Office, etc.

Ohmic Works, Queensway, Ponders End, Middlesex. (Enfield 2252, 2253 and 2763)

A Selection of Books for Engineers and Students

FOUNDATIONS OF TECHNICAL ELECTRICITY

By E. Mallett, D.Sc., M.I.E.E., A.M.Inst.C.E., F.Inst.P., and T. B. Vinycomb, M.C., M.A., F.Inst.P. An invaluable book for students preparing for the National Certificate, City and Guilds, and other examinations. 188 pages. Illustrated. 5/- net (by post 5/5).
"An excellent volume at a moderate price."—*Technical Journal*.

TELEGRAPHY

By T. E. Herbert, M.I.E.E., Superintending Engineer, Post Office Engineering Department. A standard text-book. 1,224 pages. 750 illustrations. Fifth Edition. 20/- net (by post 20/6).

PRIVATE AUTOMATIC BRANCH EXCHANGES

By R. T. A. Dennison, of the Engineer-in-Chief's Office, G.P.O., London. 304 pages. Illustrated. 5/- net (by post 5/4½).

RELAYS IN AUTOMATIC TELEPHONY

By R. W. Palmer, A.M.I.E.E., Assistant Engineer, G.P.O., London. 190 pages. Illustrated. 10/6 net (by post 10/10½).

THE CALL INDICATOR SYSTEM IN AUTOMATIC TELEPHONY

By A. G. Freestone, of the Automatic Training School, G.P.O., London. 124 pages. Illustrated. 6/- net (by post 6/4).

OUTLINE NOTES ON TELEPHONE TRANSMISSION THEORY

By W. T. Palmer, B.Sc., Wh.Ex., A.M.I.E.E. 176 pages. 4/- net (by post 4/5).

PRACTICAL TELEPHONE HANDBOOK AND GUIDE TO THE TELEPHONIC EXCHANGE

By J. Poole, A.M.I.E.E., Wh.Sc. Seventh Edition, revised and enlarged. 895 pages. 685 illustrations. 18/- net (by post 18/6).

AUTOMATIC TELEPHONY SIMPLIFIED

By C. W. Brown, A.M.I.E.E., Engineer-in-Chief's Department, G.P.O., London. 180 pages. 81 illustrations. Second Edition. 6/- net (by post 6/4).

Order from a bookseller or direct from

PITMAN HOUSE, PARKER ST., **PITMAN** KINGSWAY, LONDON, W.C.2

X

A SPOTLIGHT SHINES

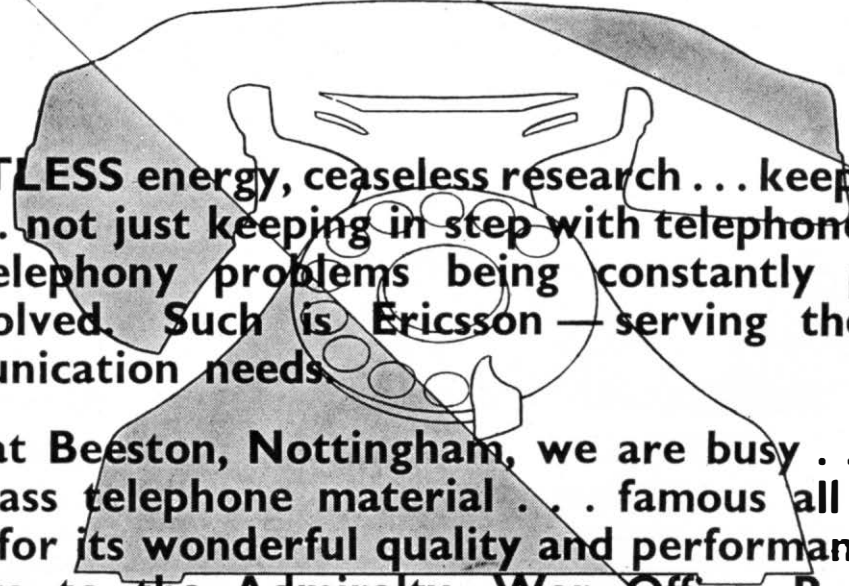

RESTLESS energy, ceaseless research . . . keeping ahead . . . not just keeping in step with telephone progress . . . telephony problems being constantly probed — and solved. Such is Ericsson — serving the world's communication needs.

Here at Beeston, Nottingham, we are busy . . . making first class telephone material . . . famous all over the world for its wonderful quality and performance. Contractors to the Admiralty, War Office, Post Office, Railways, Mines, Colonial Govts., etc.

We manufacture, supply and instal complete automatic exchanges of the "director" and "non-director" types for any number of lines.



*Informative illustrated
literature sent post free.*

Ericsson

TELEPHONES LTD.,
67/73, Kingsway, London, W.C.2
Telephones : 3271/2/3 HOLborn
(FACTORY : BEESTON, NOTTINGHAM)

THE HOME OF A GREAT TELEPHONE SYSTEM

ON *Ericsson* PROGRESS

1. Microscope Examination of the Structure of Raw Materials.

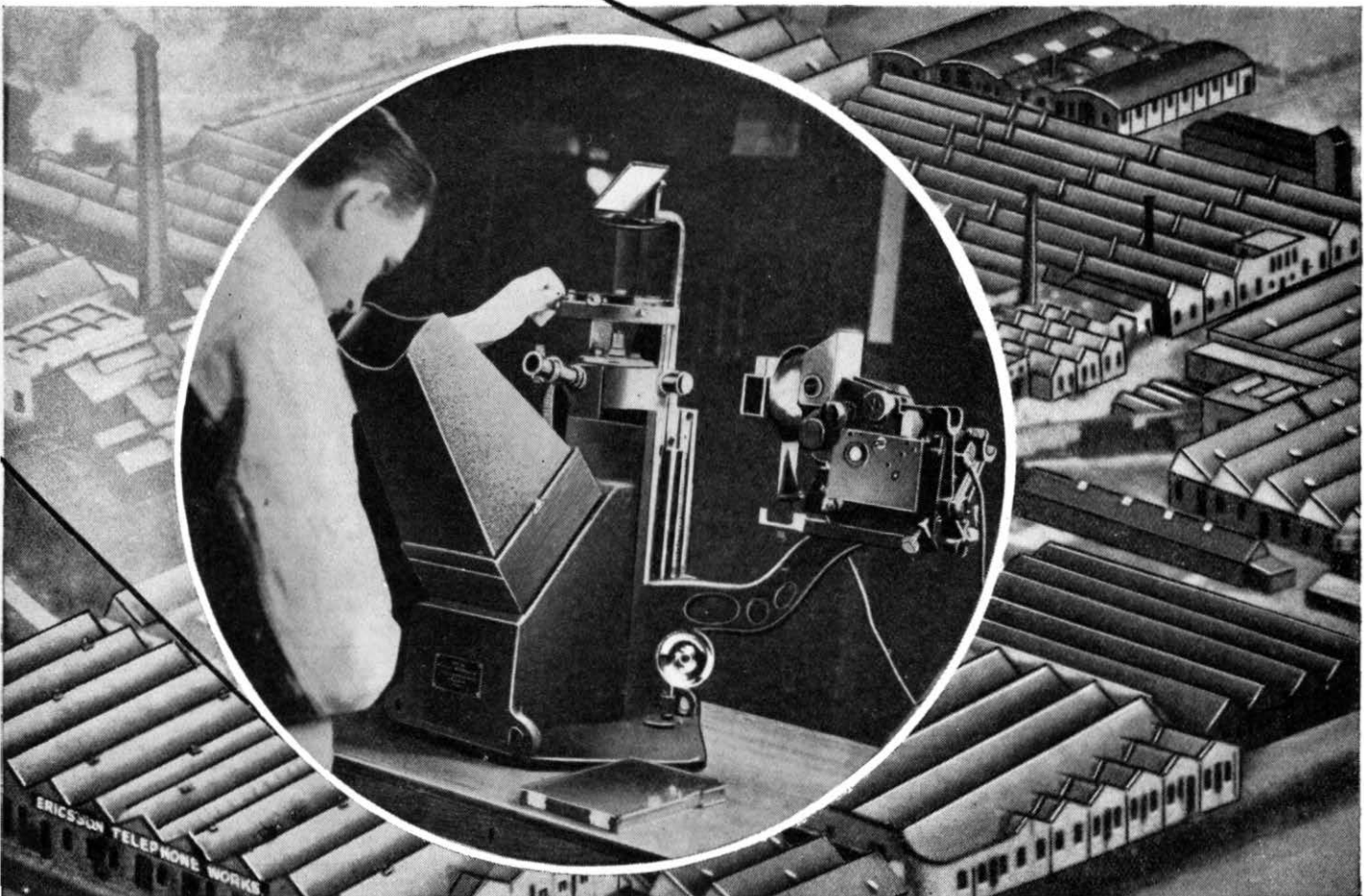

AUTOMATIC STAMP SELLING MACHINE

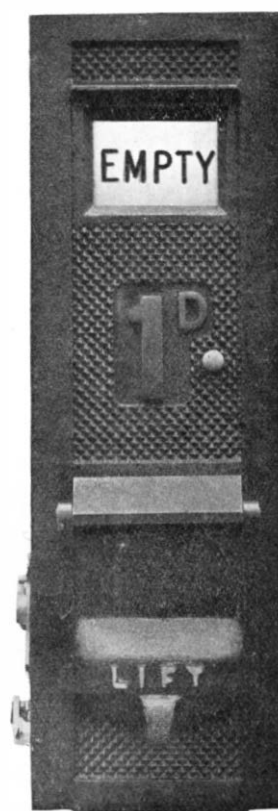
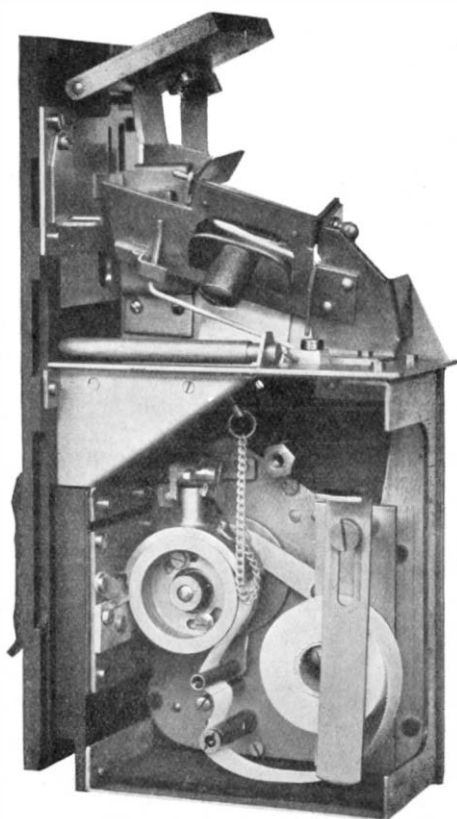

HALL TELEPHONE ACCESSORIES (1928) LIMITED

REGISTERED OFFICE & WORKS:

70 DUDDEN HILL LANE, WILLESDEN, LONDON, N.W.10

TELEPHONE : WILLESDEN 5141 2/3

*Suppliers to the British Post Office, the Air Ministry, the Admiralty, and Dominion and
Colonial Governments.*

MANUFACTURERS OF

PREPAYMENT TELEPHONE MULTI-COIN COLLECTORS, PRE-SELECTING AUTOMATIC DIALS,
AUTOMATIC STAMP SELLING AND AUTOMATIC SLOT MACHINES,
BUS AND TRAM TICKET PRINTING AND ISSUING MACHINES,
FIRE ALARM APPARATUS AND SCIENTIFIC INSTRUMENTS

MARCONI-E.M.I. TELEVISION

The Marconi - E.M.I. Television System embodies complete equipment for the radio transmission of scenes enacted either in a studio or in the open air as well as projected by the usual film process. The Marconi-E.M.I. equipment will transmit any number of lines, as required by local conditions, up to 405 lines, and gives flickerless interlaced pictures.

The Marconi Company's unique experience of radio research and communication, combined with the vast experience in vacuum and electron physics of Electric and Musical Industries Ltd.—in which departments it possesses one of the largest research organisations in Europe—ensures the finest television transmission obtainable to-day.

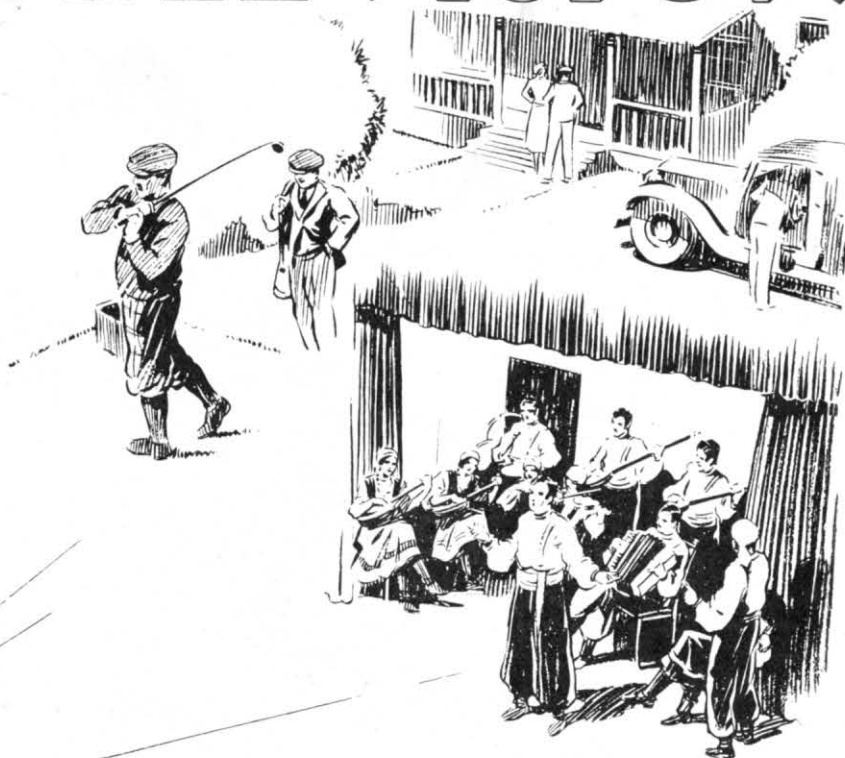

The special aerial system used in connection with these transmitters is the result of intensive Marconi-E.M.I. research. It is designed to direct the radiation horizontally with equal all-round intensity and to provide an even response level over the wide frequency band demanded by the nature of television transmission.

The highly sensitive and flexible Emitron camera enables exterior and interior scenes to be transmitted, without any intermediate processes. It also offers Broadcasting Authorities the most economical facilities possible for the radiation of their existing programmes as television pictures.

The Marconi-E.M.I. Television Company, Ltd., is prepared to tender for all types of television transmitting apparatus and equipment.



MARCONI-E.M.I. TELEVISION CO., LTD.

What . . .

BETTER COMPANIONS

for your Wireman's Tool Kit than . . .



★
**wee-Megger
 Tester and Megger
 Circuit Tester?**

£14.0.0 buys the two instruments illustrated here in a leather sling case with set of three leads and instruction and log books—a complete outfit for INSULATION AND CONTINUITY TESTING. Size 8" x 7" x 4½". Weight 6½ lbs. Write for Publication No. **X.42**

★
Megger
 registered Trade Mark

Announcement of

EVERSHED & VIGNOLES, Ltd., CHISWICK, LONDON, W.4.

Telephone: Chiswick 1370

Telegrams: "Megger", Chisk, London.

SIMPLIFIED CONSTRUCTION OR SPECIAL FINISH with

 **WESTINGHOUSE** 

METAL RECTIFIERS FOR BROADCASTER H.T. SUPPLIES

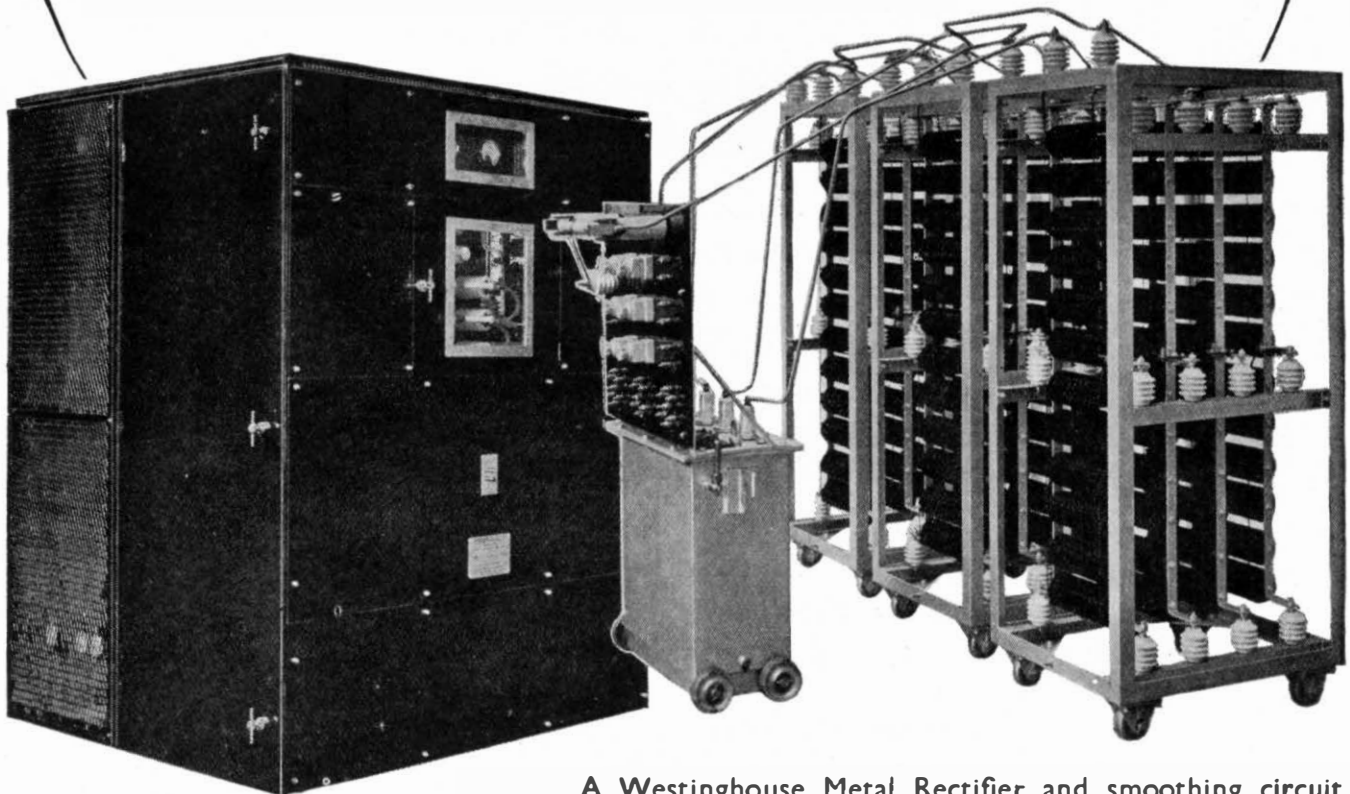

Above is illustrated an H.T. supply unit with an output of 6,000 volts 1 A, smoothed 0.03 per cent. ripple, supplied to the New Zealand Government. This type is specially finished to match the radio equipment, and includes rectifier, mains transformer and full protective and alarm circuits. On the right is a 5,000 V 2 A unit of the simplified construction type and includes rectifier and mains transformer only.

A Westinghouse Metal Rectifier and smoothing circuit has the great advantage that it is a static apparatus requiring neither attention, maintenance nor renewal. Its action is instantaneous. It can be supplied with special finish to match the remainder of the equipment, or as a simple rectifier and mains transformer unit without case.

WESTINGHOUSE BRAKE & SIGNAL CO., LTD., 82 York Rd., King's Cross, London, N.1

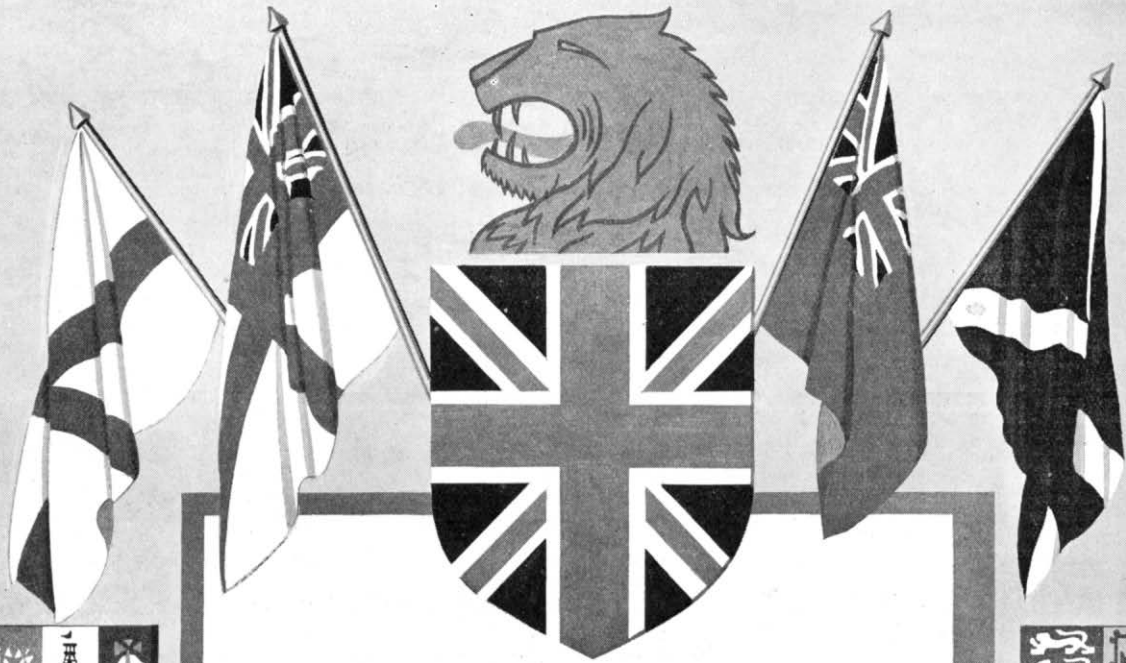

EMPIRE SERVICES

Vital communications and services throughout the British Empire are using and relying upon Alton Batteries of Merit. Under many climes and many conditions these world-famed Batteries are serving as only true British Craftsmanship knows how.

THE ALTON BATTERY CO. LTD.
ALTON, HANTS.

Telephone : Alton 367 & 368. Telegrams : "Battery, Alton."

London Office : Donington House, Norfolk Street, W.C.2



NEW ZEALAND



AUSTRALIA



S. AFRICA

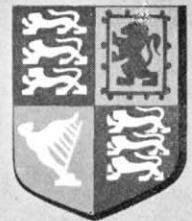

GT. BRITAIN



CANADA



INDIA



YOU HAVE BEEN WARNED BY RADIO

Professor Hilton on November 19th, 1936, from the B.B.C. broadcast a warning. The warning was to the effect that while there are many really good and reliable Colleges teaching by correspondence, there are many others which are colleges by name only. He said some so-called colleges rented a couple of rooms in a large building in a well-known street. Some made great promises which they did not intend to fulfill. Some claimed successes they could not prove. In some cases the names of prominent men were quoted who were in no way connected with the working of the College.

NOW BE ADVISED BY ME

The big name of a College is no proof of its national standing. The Bennett College has been established over 30 years and our entire building is devoted to Bennett College work. No other business of any kind is either on or attached to The Bennett College. We have seating accommodation for over 10,000. We have a permanent staff of over 190 people on the College premises. Our Professional Staff have all passed their examinations, and our tutors are all experts in their own specialised work. We do not send out any homework to be corrected by tired, spare-time tutors. All students' homework is corrected on the College premises the same day that it arrives, and is returned by evening post. This College is Technical, Scientific, General and Commercial, thus enabling us to cater for all requirements; this is important to Cost and Works Accountants, and all who have to deal with rate-fixing, machining-allowance, and it is also of great importance in many of the Civil Service Examinations. This is an entirely British College. Most of our textbooks are written on the College premises by our professional staff, especially for tutorial purposes. Our tutors specialise in teaching students for the examinations they themselves have already passed.

THERE IS NO OTHER COLLEGE IN THIS KINGDOM THAT CAN CLAIM ALL THE ABOVE ADVANTAGES

It is not necessary for students to attend the College: we can send exactly the same tuition to you by post for a reasonable fee payable monthly. Anyone who reads the journals knows that there are many things advertised that one can study, and any kind of study is good. It is training for the

brain, but the best thing to study, surely, is a course specially prepared to teach your own vocation, or prepare you for the examinations which you have in view. Knowing that you are master of your job gives you self-confidence and personality, but a Diploma from a College is absolute proof of your efficiency. We have agencies in all English-speaking corners of the world. The nature of our business makes us keep in touch with employment requirements in all parts of the world, therefore we specialise in preparing students for the good positions which we know exist, and for all worth-while examinations.

THE ABOVE VAST ORGANISATION CAN HAVE BEEN CREATED ONLY BY THE SUCCESS OF OUR STUDENTS

There is a tide in the affairs of man which, if taken at the flood, leads on to fortune and success. There are three things which come not back: the sped arrow, the spoken word and the lost opportunity—this is your opportunity. If it is your desire to make progress and establish yourself in a good career, write to us for free particulars on any subject which interests you, or if your career is not decided, write and tell us of your likes and dislikes, and we will give you practical advice as to the possibilities of a vocation and how to succeed in it. You will be under no obligation whatever. It is our pleasure to help. We never take students for courses unless we feel satisfied they are suitable. Do not forget that success is not the prerogative of the brilliant. Our experience of over 30 years proves that the will to succeed achieves more than outstanding brilliancy.

LET ME BE YOUR FATHER

Let me tell you how to make a success of your career. If your future is undecided or appears unsatisfactory, let us talk it over together. I want to help, and it will cost you nothing to get my help; you will be under no obligation whatever.



J. H. Bennett

DO ANY OF THESE SUBJECTS INTEREST YOU?

- | | | |
|---|--|------------|
| Accountancy Examinations | Matriculation. | Metallurgy |
| Advertising and Sales Management | Mining, all subjects | |
| A.M.I. Fire E. Exam. | Mining, Electrical Engineering | |
| Applied Mechanics | Motor Engineering | |
| Army Certificates | Motor Trade | |
| Auctioneers and Estate Agents | Municipal and County Engineers | |
| Aviation Engineering | Naval Architecture, Pattern Making | |
| Banking, Boilers | Police, Special Course | |
| Book-keeping, Accountancy and Modern Business Methods | Preceptors, College of Pumps and Pumping Machinery | |
| B.Sc. (Eng.) | Radio Service Engineering | |
| B.Sc. (Estate Management) | Road Making and Maintenance | |
| Building, Architecture and Clerk of Works (speciate) | Salesmanship, I.S.M.A. | |
| Cambridge Senior School Certificate | Sanitation | |
| Civil Engineering, Civil Service | Sheet Metal Work | |
| All Commercial Subjects | Shorthand (Pitman's) | |
| Commercial Art (eering) | Shipbuilding | |
| Concrete and Structural Engineering | Structural Engineering | |
| Draughtsmanship. All branches | Surveying | |
| Engineering. All branches, subjects and examinations | Teachers of Handicrafts | |
| General Education | Telephony and Telegraphy | |
| G.P.O. Eng. Dept. | Transport Inst. Exams. | |
| Heating and Ventilating | Weights and Measures Inspector | |
| Industrial Chemistry | Welding (phony) | |
| Insurance. Mathematics | Wireless Telegraphy and Tele-Works Managers | |

If you do not see your own requirements above, write to us on any subject. Full particulars free

We are prepared to produce, on demand, over 10,000 unsolicited testimonials from successful students, or in default we will hand over £100 to charity.

SIGNS OF THE TIMES

ARMAMENTS

means

MASS PRODUCTION

means

JIGS, TOOLS, FIXTURES, ETC.

Our extended course on DRAUGHTSMANSHIP teaches the Design. Our PRACTICAL ENGINEERING teaches the manipulation.

THE AIR FORCE

is to be increased. All branches of

ENGINEERING MUST DEVELOP

CIVIL SERVICE

Suitable to both sexes. Ages 15½ to 24. Pay Cuts have been restored.

G.P.O. ENG. DEPT.

CUSTOMS AND EXCISE; INSP. OF TAXES, Etc. NO EXPERIENCE REQUIRED. OPEN EXAMS.

TELEPHONY, RADIO AND MOTOR ENGINEERING are expanding rapidly. There are lots of vacancies.

MATRICULATION

There are many ways of commencing a career, but Matriculation is the jumping-off board for all the best ones. We prepare Candidates for all.

INSTITUTE EXAMS.

TECHNICAL. ACCOUNTANCY. SECRETARIAL. INSURANCE. Etc.



CAN YOU CHANGE MY EXPRESSION? IF SO, YOU MAY BE THE ARTIST THAT COMMERCE IS WAITING FOR

Just try for yourself, trace or draw the outline and then put in the features.

There are hundreds of openings in connection with Humorous Papers, Advertisement Drawing, Posters, Calendars, Catalogues, Textile Designs, Book Illustrations, etc., etc. 60% of Commercial Work Art is done by "Free Lance Artists" who do their work at home and sell it to the highest bidders. Many Commercial Artists draw retaining fees from various sources; others prefer to work full-time employment or partnership arrangement. We teach you not only how to draw what is wanted, but how to make buyers want what you draw. Many of our students who originally took up Commercial Art as a hobby have since turned it into a full-time paying profession with studio and staff of assistant artists—there is no limit to the possibilities.

Let us send full particulars for a FREE TRIAL and details of our course for your inspection. You will be under no obligation whatever.

Jim Duak

Art Dept. 24.

YOUNG MEN

Young men physically fit and whose careers are not definitely fixed should join the Police Force. We have special Courses for Entrance and Promotion. 1s. per week brings success. Full Particulars Free.

Address:

POLICE DEPT. 24.

ENGINEERS

Engineers, now is your chance to dig yourselves into a Key position and make your future solid. It needs Technical Training; we can give you that by post. Full particulars free, Dept. 24.



NOTE ADDRESS : DEPT. 24 BENNETT COLLEGE, SHEFFIELD



Standard CONDENSERS for ALL REQUIREMENTS

OUR North Woolwich Factory is equipped with the most modern plant for production of Power, Telephone and Radio Condensers of the highest possible quality. If you are in the market for condensers we shall welcome the opportunity of quoting you upon receipt of your requirements.

Standard Telephones and Cables Limited

NORTH WOOLWICH, LONDON, E.15
 Telephone - - - - Albert Dock 1401
 BRANCHES & REPRESENTATIVES THROUGHOUT
 THE WORLD

THE POST OFFICE ELECTRICAL ENGINEERS' JOURNAL

Vol. XXX

April, 1937

Part I

Present Tendencies of Power Development and their Repercussions upon Telecommunication Systems

P. B. FROST,
B.Sc. (Eng.), M.I.E.E.

This article reviews the development in electric power systems and the possible effects on the telephone network from the aspects of danger to personnel, damage to plant and noise interference

GENERAL PRINCIPLES OF TELEPHONE INTERFERENCE

BEFORE telephone interference from power sources can be understood it is necessary to visualise the conditions under which a power system may be capable of causing these disturbances and then to consider the characteristics of a telephone circuit which make it sensitive to the disturbing conditions.

A power system can cause disturbance in a neighbouring telephone line only if it has an external electric or magnetic field.

External Electric Fields.

An external electric field exists when the potentials of the individual line wires are not balanced with respect to one another and to earth. Even when the potentials of the individual wires are so balanced the wires may be so widely separated as to permit each to have an electric field of disturbing strength in its immediate vicinity. It is obvious that a high voltage line in a lead covered cable does not produce an external electric field. A 3-phase system earthed at the neutral, or insulated from earth and balanced in respect to earth by regular rotations, does not give rise to an external electric field except in the close vicinity of individual wires. On the other hand, a single-phase spur from a 3-phase system earthed at the neutral has unbalanced voltages with respect to earth and therefore produces an external electric field.

A 3-phase system insulated from earth and balanced in respect to earth by regular rotations creates no external field unless the balance of the potential to earth of individual wires is upset by an accidental earth on one phase. As a rule, electric fields do not cause trouble except with very high operating voltages or very close separating distances. The effect of an electric field need only be taken into consideration in three cases which occur in practice :

- (1) An insulated 3-phase system which is continued in operation with an earth fault on one phase.
- (2) A single-phase spur from any 3-phase system and
- (3) An electrified railway with overhead contact wire or wires, with return by the rails.

External Magnetic Fields.

An external magnetic field exists when the currents flowing in the power lines are unbalanced, so that a residual current returns from some distant point through the earth. It may also be remarked that even when there is no residual current, if the conductors are not close together an external magnetic field will be formed in the close vicinity of individual conductors of the power line.

When some part of the current in a polyphase system returns by the earth it distributes itself in the earth to a great depth and extends laterally over a very wide area. The effect of the current is to produce a pulsating magnetic field which induces currents in any telephone line roughly parallel with the power line. Fig. 1 indicates a step-up transformer with earthed neutral feeding a high voltage

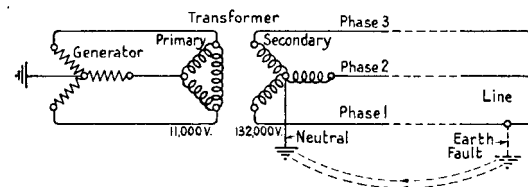

FIG. 1.—EFFECT OF EARTH FAULT ON 3-PHASE SYSTEM.

transmission line. The path of the unbalanced fault current returning through the earth from the fault on phase 1 is indicated.

The conditions under which a power system gives rise to a current of fundamental frequency, flowing in the earth, must now be considered.

A 3-phase system earthed at the neutral carries balanced in-phase currents and balanced capacitance or charging currents, provided that all three lines are balanced in respect of their insulation and capacitance to earth. When a fault to earth on one line occurs the faulted phase line carries, in addition, a current which returns from the fault by way of the earth. The capacitance to earth of the faulted phase is greatly reduced and the capacitance currents in the system also become unbalanced.

An earth fault on an insulated system, by upsetting the balance of the capacitances of the lines to

earth, also leads to an unbalanced residual charging current, which returns by the earth.

An insulated system will also cause a flow of current in the earth when two earth faults exist on different phases simultaneously, at a distance from one another.

Any power line which is built unsymmetrically and is not transposed or rotated will also have an unbalanced or residual charging current, of which the return path is the earth. An extreme example of an unsymmetrical system is an alternating current railway in which the uninsulated rails carry only part of the return current, much of which finds its way back by the earth.

So far the effect of currents at the fundamental frequency only have been considered, but it may be taken that (in 3-phase systems earthed at the neutral) the same remarks apply to any harmonics of odd frequency, such as the 5th, 7th, 11th, 13th, 17th, 19th, etc. The ternary harmonics (3rd, 9th, 15th, 21st, etc.) are, however, always in phase with each other in all the line conductors, and therefore together produce a residual or resultant current in the system as a whole, even in a perfectly symmetrical system; in general any ternary harmonic voltages present in the source may produce charging currents of the same frequency that return by the earth.

No alternating current system is free from harmonics, though every effort may be made to reduce their magnitude. Even direct current systems fed from rotating plant, and especially when fed from rectifiers, contain alternating components superimposed on the direct current, which, if the system is not uniformly balanced in insulation and capacitance to earth, will return by the earth and cause interference in imperfect telephone circuits.

Effect on Telephone Circuits.

The chief causes of the flow of currents in the ground having been briefly indicated, consideration may now be given to their effect on telephone circuits exposed to the pulsating magnetic field. In both wires of a telephone pair E.M.F.'s will be induced, but these will not be equal because the two wires are not in identically strong fields. A perfect system of transposition or rotation of the telephone pair may eliminate this inequality, but any lack of equality of resistance or of insulation resistance or of capacitance to earth of the two wires forming the pair, or any lack of uniformity in the distribution of these characteristics along the line, may cause currents to flow round the loop through the terminal apparatus and therefore may cause noise interference in the receivers. Unbalance to earth of the terminal apparatus produces the same result. Telephone circuits in cables are so nearly balanced and so well rotated as not to suffer appreciably from noise interference due to imperfect balance of the line, but terminal unbalance may still cause noise interference if the circuits are subjected to longitudinal induced noise voltages.

It is also important to note that a perfect telephone line which is exposed to longitudinally induced noise voltage, although silent when connected to a perfectly

balanced termination, will become noisy if it is connected through to an unbalanced local line or even to a balanced line which is connected to unbalanced terminal apparatus.

When an open wire telephone circuit is subjected to the influence of a pulsating electric field, imperfect balance of the capacitances of the two conductors to the power line or to earth, unequal ohmic resistance or unequal insulation resistance of the two conductors, lack of uniformity of the distribution of these characteristics along the line, or imperfect balance to earth of the local line or terminal apparatus, will result in a residual current circulating through the terminal receivers and therefore in noise interference.

A telephone circuit in an earthed lead sheathed cable is, of course, completely screened from the effects of an electric field. The sheath also affords a measure of screening against induced voltages due to the magnetic field, particularly at audio frequencies.

There is one other important aspect of power interference. In the case of severe exposures such as occur with long parallels or with small separating distances the earth fault current of the power line may be so great as to induce in the parallel telephone line very high longitudinal voltages capable of causing the operation of protectors and therefore giving rise to acoustic shock or creating, while they last, a dangerous hazard for linemen. The precautionary measures available to the power engineer on the one hand and to the telephone engineer on the other to keep this effect within bounds are described later. It should be emphasised that, although a perfect telephone circuit is immune from noise interference, the telephone engineer has no defence within his own hands against longitudinal induced voltages. At best he can reduce their magnitude or mitigate their effects.

GENERAL REVIEW OF THE TENDENCIES OF POWER AND TELECOMMUNICATION DEVELOPMENTS.

The following aspects of power development will be briefly considered :—

The extensive development of the grid with its network of 132 kV overhead lines, its secondary lines at 33 kV and the many lower voltage spurs.

The growing demand for multiple earthing of both high and low voltage systems.

The use of electrode boilers and water heaters.

The extensive adoption of mercury arc rectifiers.

The growth of railway electrification.

The gradual suppression of tramways and growth of trolley vehicle systems.

The growing need for joint construction.

The use of P.O. lines for control circuits and indicating circuits between power stations.

The future of transmission by direct current.

Concurrently with these tendencies we should remember what is happening in the development of telecommunication circuits. The main trunk and junction system of the country is rapidly going into

underground cables, a step rendered possible by the development of thermionic valves. A gradual displacement of C.B.S. No. 1 exchanges is taking place and less use is being made of the earth for signalling. Other tendencies include the extension of carrier working, the practical disappearance of earth return talking circuits and a gradual disappearance of earth return telegraph circuits in favour of V.F. telegraphs. It must, however, be remembered that in extending the distances over which dialling into automatic exchanges is practised there may be a considerable extension of battery dialling with earth return. There are also many types of coin box circuits still in use which employ some form of earth return circuit in the calling condition, but their length is generally short, and cases of noise interference during the talking condition are of rare occurrence.

THE DEVELOPMENT OF OVERHEAD POWER LINES.

The development of overhead power lines has progressed very rapidly since the Central Electricity Board was set up in 1926. The Grid is now practically complete and forms the backbone of the system of electricity distribution in bulk. Its effect has, therefore, been to stimulate the growth of an elaborate network of lines in all parts of the country. Overhead power lines have brought problems to the Post Office, which may be considered under three main headings.

1. The danger of physical contact between power lines and telecommunication lines.
2. The dangers arising from high induced voltages in telephone lines caused by heavy earth fault currents from parallel power lines.
3. The general degradation of telephone circuits by noise induction from the residual or unbalanced component currents in power lines.

Physical Contact, Low Voltage Lines.

With low voltage lines the danger of contact can be materially reduced by providing covered conductors at crossings and proximities.

The power wires or the telephone wires may be protected by the use of an insulating covering of P.B.J. or V.C.J. Alternatively, earthed guard wires may be used to prevent contact with 600 volt trolley wires. P.B.J. consists of impregnated paper tapes, a cotton lapping, and a braiding which is impregnated with linseed oil and red lead and ultimately coated with paraffin wax. V.C.J. covering is similar, but varnished cambric is used in place of paper, and gives a higher insulation. This covering has excellent weathering properties. A perfect insulating covering has not yet been discovered, but a number of manufacturers is still investigating the problem.

Such accidents as have occurred have been mainly due to abrasion of the protective covering by the sawing action of a broken bare wire being drawn across it. When the P.O. wires cross above power wires it will generally be arranged in future that the neutral or alternatively an earthed guard wire is strung above the live insulated power wires so as to prevent any direct contact.

Physical Contact, High Voltage Lines.

With high voltage lines the utmost care must be taken, by adequate separation and by more robust construction at crossings, to prevent direct contact with telephone wires. Collapse under exceptional storm conditions may be prevented by additional staying. The risk of a conductor falling may be minimised by the use of duplicate insulators, bridles and stranded conductors. Insulators of a voltage flash-over value higher than that of those on the rest of the line may be used at crossings, so as to prevent a flash-over which might burn the conductor through if the arc persisted. Arcing horns are often used to prevent the burning of the conductor and to deflect the arc from the insulator.

At the majority of crossings of Post Office wires substantial earthed guards are provided between the power wires above and the telephone wires below, so that a broken power wire will be caught by the guard and also so that a broken telephone wire may not be blown by wind into contact with a power wire. At sharp angles separate vertical side guards may be used.

At the 132 kV crossings the more certain precaution of placing the telephone wires in U/G cable has always been adopted—indeed this form of crossing is accepted as an alternative to guarding at the lower high voltages where the telephone lines are subscribers' lines or short junction lines, and the loss of transmission efficiency, which undergrounding involves, can be tolerated. Although at such underground crossings a special low capacitance cable is employed, the losses due to reflection, when a number of crossings of one route occur, are considerable and are to be avoided if possible on long lines. Fortunately, long overhead lines are becoming rare.

Longitudinal Induced Voltages.

It has been stated that where power lines and telephone lines run even approximately parallel for long distances, a heavy unbalanced current due to a fault on one phase, which current returns by the earth to the earthed neutral point of a power system, will induce magnetically a high longitudinal voltage in the telephone lines. Every effort is therefore made to avoid such severe exposures as would result in the voltage in the telephone lines exceeding 300 during the short time, sometimes only a fraction of a second, but sometimes several minutes, between the occurrence of the fault and the operation of the circuit breaker which cuts the current off. In many power systems such circuit breakers are arranged to close automatically three times before remaining open.

A great deal of experimental work has been necessary to verify the truth of the formulæ derived by Carson and Pollaczek concerning the coupling between parallel lines with earth return. It was necessary to study the depth and lateral distance to which the alternating earth currents spread and this was found to depend upon the soil resistivity, not only near the surface but of the rock substrata, and also upon the frequency. The separating distance between the lines plays an important part. The principles were only thoroughly established after

experimental work had been done in several countries under widely varying conditions.

When the Post Office receives a notice of the intention to construct a new power line it is necessary to refer to the map record of high voltage power lines in order to ascertain what is the most severe coupling between the new line, including any section of the existing power network of which it forms an extension, and the most severely exposed telephone line. In making this computation attention must be paid to the varying separation between power and telephone lines and in calculating each component part of the induced voltage the appropriate ground resistivity must be obtained from the resistivity map, which is reproduced to a small scale in Fig. 2. In important cases the resistivity may have to be checked by measurement on the site, or, where the ground is known to be stratified, the equivalent resistivity may be computed with sufficient accuracy from the curves referred to below.

When the appropriate resistivity has been determined the mutual inductance curves shown in Figs. 3 and 4 enable the induced voltage to be computed.

These curves are suitable for use when the soil is homogeneous, but where the earth is stratified and there is a wide difference between the conductivity of the upper and lower layers their use would lead to errors.

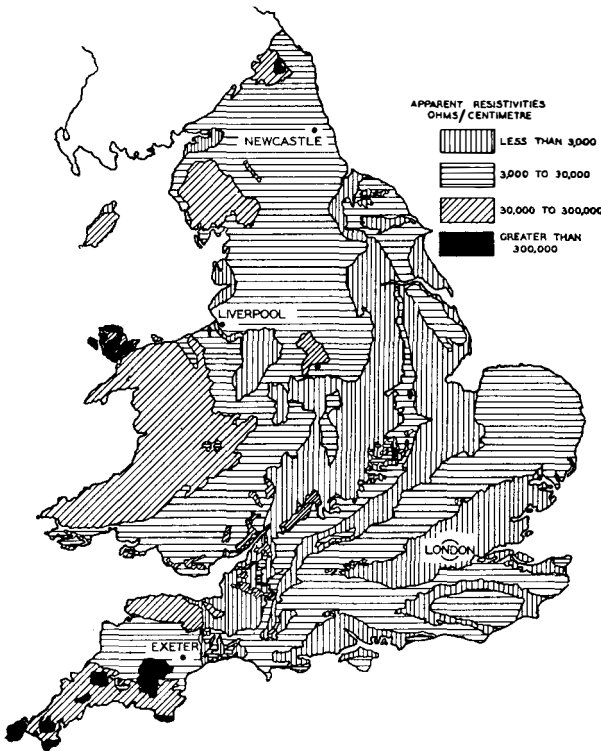

FIG. 2.—MAP SHOWING EARTH RESISTIVITY.

The P.O. Research Branch has recently prepared a set of curves based on mathematical calculations from which the equivalent resistivity of the soil may be computed if the conductivity of each of the two

assumed homogeneous layers and the depth of the upper one are known.

When the equivalent resistivity has been determined the curves of Figs. 3 and 4 are used in the

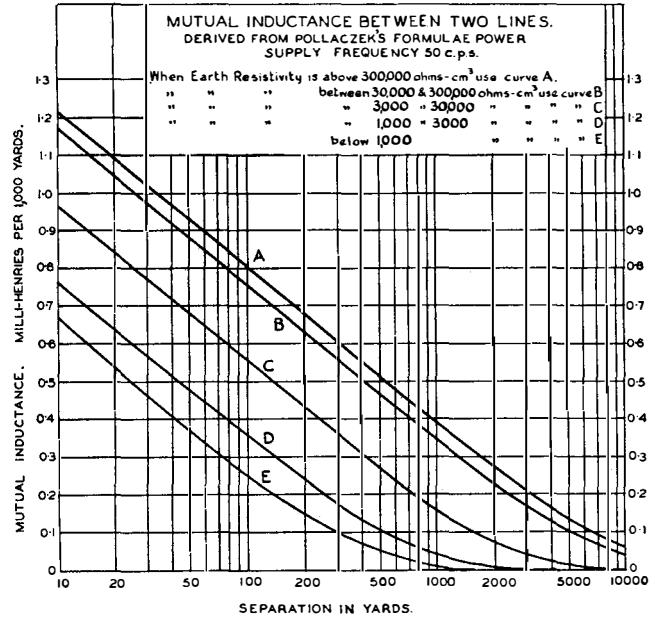

FIG. 3.—CURVES FOR THE CALCULATION OF MUTUAL INDUCTANCE.

normal way to find the corresponding induced voltage for the separating distance of each section of exposure.

When the total induced voltage per ampere of fault current has been calculated, it is a simple matter to determine what maximum fault current can be tolerated, assuming that the total induced voltage must be limited to 300 V. or in exceptional cases to 420 V.

The power undertaker is then advised what is the maximum fault current that can be tolerated and is expected to ensure that it is not exceeded by the use, if necessary, of an impedance between the neutral point and earth or by the use of series reactances in the lines.

An alternative available to the power engineer is to avoid earthing the neutral and to employ a system completely insulated from earth. In this case it requires simultaneous earth faults on two phases, some distance apart, to give rise to serious induced voltages in neighbouring communication lines.

Another development of comparatively recent application in this country is to earth the neutral through a very high inductance often known as a Petersen coil. If the inductance of this coil is carefully balanced against the joint capacitance of two of the line wires, an earth fault on the third conductor will not result in any appreciable current flowing through the fault. Providing the not unusual practice of short-circuiting the Petersen coil to clear those faults which are not self-suppressing is prohibited, the use of Petersen coils promises to be a satisfactory solution of the induced voltage problem.

In some of the Grampian Co.'s lines involving extremely long parallels this scheme is being

adopted, but several Petersen coils located at different points on the system are being used.

In demanding that a considerable impedance of any kind be connected between neutral and earth it must be remembered that the additional expense of

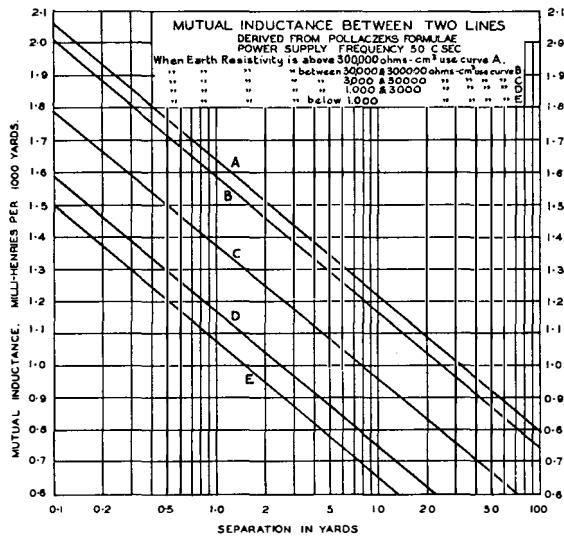

FIG. 4.—CURVES FOR THE CALCULATION OF MUTUAL INDUCTANCE.

insulating the transformers for the full phase voltage even at the neutral point will have to be faced, whereas it is not uncommon to grade the insulation of very high voltage transformers to save expense.

The objections to high induced voltages in telephone lines are that they may

- (1) create a dangerous hazard for linesmen both on overhead lines and to a lesser extent on lines in cable.
- (2) cause the operation of protectors and, as the protector on one leg always operates before that on the other, a heavy rush of current will occur through the terminal apparatus, including the receiver, as will be clear from Fig. 5. Such a rush of current may be the cause of acoustic shock.
- (3) in some circumstances cause damage to apparatus and give rise to exchange fires.

Safety Precautions on Telephone Lines.

Cases arise in which it is impracticable for any further measures of precaution to be taken by the power undertaker and it is therefore inevitable that precautionary steps should be taken by the Post Office. On overhead lines exposed to the risk of high longitudinal voltages the risk of shock can be reduced by removing the pole earth wires from contact with the arm bolts and also by cutting out about a foot of the earth wire at ground level, a step which has been found not to impair the value of the earth wire as a protection against atmospheric disturbances. Insulators may also be inserted in stay wires.

The lines themselves can be broken up by means of one to one transformers into sections of such length that not more than 300 volts would be induced in any one, under the most severe conditions. This step

is naturally limited by the transmission loss permissible and by the requirements of dialling and junction circuit signalling.

Transformers suitable for speech transmission with minimum loss are not suitable also for trans-

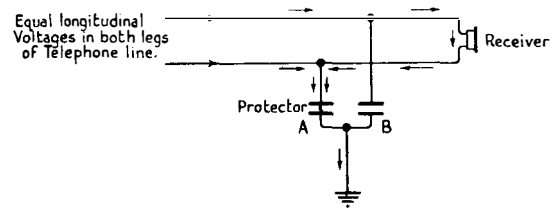

FIG. 5.—CAUSE OF CURRENT IN RECEIVER WHEN A LINE SUBJECTED TO HIGH LONGITUDINAL VOLTAGE DISCHARGES THROUGH ONE PROTECTOR BEFORE THE OTHER. GAP A HAS BROKEN DOWN BEFORE GAP B.

mitting signalling currents at $16\frac{2}{3}$ c.p.s. Signalling at 500/20 c.p.s. is practicable, but the available apparatus is too expensive and bulky for use where the number of circuits is very small and furthermore the accommodation in small country offices is limited.

An important step towards the solution of the problem will have been taken when a method of signalling which employs signalling currents within the frequency range effectively transmitted by underground lines has been made available at low cost.

The only other protective method available at present is to provide gas-filled protectors at suitable intervals to ensure low impedance paths to earth which will break down under the influence of a longitudinal induced voltage of dangerous magnitude and allow a current to flow in the line sufficiently high to dissipate the induced voltage. As such protectors may be damaged by lightning they should be shunted by a spark gap, a small inductance being used in series with each tube protector. Lightning

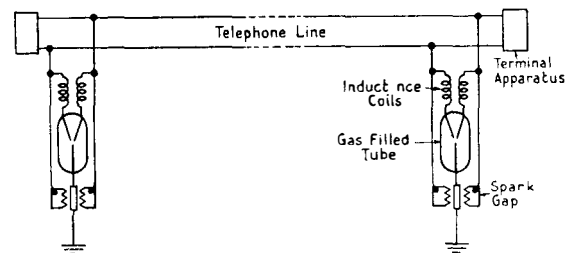

FIG. 6a.—DIAGRAMMATIC ARRANGEMENT OF TWO GAS-FILLED DISCHARGE TUBES CONNECTED TO A TELEPHONE LINE.

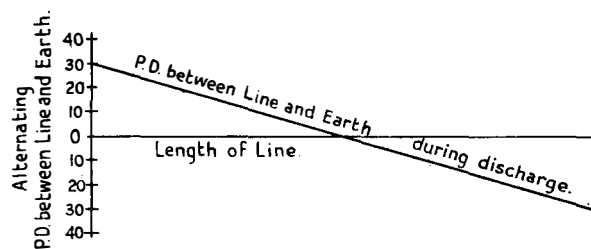

FIG. 6b.—CURVE SHOWING INSTANTANEOUS VALUE OF P.D. BETWEEN LINE AND EARTH AT ANY POINT ON THE LINE BETWEEN TWO GAS-FILLED TUBES WHEN THEY ARE DISCHARGING. THE EXPOSURE TO THE POWER LINE IS ASSUMED TO BE UNIFORM THROUGHOUT THE LENGTH OF THE TELEPHONE LINE.

will discharge through the spark gap, whereas power induced voltages at 50 c.p.s. will discharge through the protector tube and its series inductance relatively easily.

The tubes which are about to be used for the first time in a practical case exhibit a slight glow discharge at 150 volts and break down and form an arc at less than 250 volts. As the current rises to the capacity of the tube the voltage across the tube falls to less than 30. During operation of the tubes, therefore, no part of the lines protected should exceed this voltage to earth.

Fig. 6 shows the theoretical circuit arrangements and potential of a line protected by gas-filled tubes and Fig. 7 is a photograph of a tube suitable for

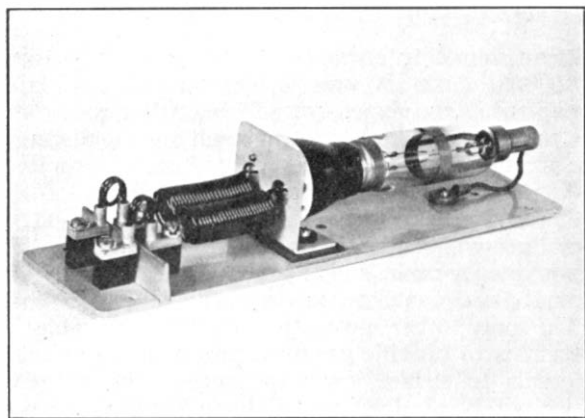

FIG. 7.—GAS-FILLED DISCHARGE TUBE.

discharging repeated impulses of 10 amperes for 10 seconds from each line wire, an interval being allowed between successive discharges for cooling. When further experience has been gained, the use of gas-filled tubes will form the subject of a separate article in this Journal.

In the comparatively rare case when it is necessary for the Post Office to lay a telephone cable in a situation in which it will be seriously exposed to power induction, recourse may be had to special types of cable sheath.

The screening factor of a cable sheath of full size, the conductivity of which is increased by the provision of a layer of heavy copper conductors under the sheath and in contact with it, may be such as to reduce the voltage induced in the conductors to one-tenth of that which would appear in open wires. The screening effect may also be materially improved by the provision of a double iron tape armouring.

The particular grade of iron used for the tape may be chosen to give the maximum screening at commercial frequencies and in the strong fields produced by heavy currents in neighbouring power circuits, or to give a maximum effect in weak fields at speech frequencies such as would be required if noise interference were anticipated.

Where the sheath is depended upon for screening it is of vital importance that it should be well earthed at frequent intervals. As good earths are difficult to construct and maintain, the continuity of the sheath should never be interrupted.

The following precautionary measures are available for reducing the risks to men working upon circuits in cables, exposed to high induced voltages.

Trunk circuits terminated on transformers may sometimes be interrupted by transformers without other drawback than transmission loss. The screening factor of the sheath of a large cable may reduce the voltage induced in the conductors to less than one-half of what it would be on open wires, similarly exposed. When a sleeve is to be slipped, therefore, the sheath must be bridged across in advance to maintain its conductance. Something can be done by providing special rubber boots and protective clothing for the men and by ensuring, by the use of dry wood guards, that during work upon conductors they do not make direct contact with earth or manhole walls.

Cable sheaths can be covered up with insulation such as old motor tyres during actual jointing work. It would not be possible to use rubber gloves.

The difficulty of the Department's problem of ensuring safety is considerably greater than that of ensuring the safe jointing of live low voltage mains, for the very reason that the presence of an induced voltage is a rare and unexpected occurrence and is usually of short duration.

Noise Interference.

With regard to the third difficulty introduced by power lines, that of noise interference, it may be said that no power system is free from the presence of a considerable number of parasitic currents of higher frequency than the fundamental of which the 3rd, 5th, 7th, 9th, 11th, 13th, 15th, 17th, 21st, harmonics are the most common. These harmonics may originate in the generating plant or may be introduced by transformers in which the iron is over-saturated.

Fig. 8 indicates the effect upon a sine wave of a third harmonic component. It will be noticed that

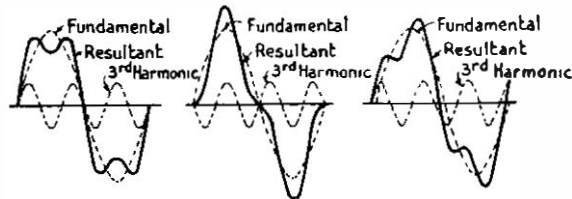

FIG. 8. RESULTANT WAVE-SHAPES OF FUNDAMENTAL AND THIRD HARMONIC.

the phase relationship between the fundamental and the third harmonic affects the form of the complex wave.

The disturbing effect upon a telephone conversation of the various individual frequencies that may be present is by no means equal. Fig. 9 gives the relative values of the average disturbing effects of the different single frequencies when the value of the voltage of each frequency, at the receiver terminals, is the same.

When endeavouring to assess objectively the disturbing effect of a power noise comprising a mixture of harmonics, it is necessary to use an instrument which will make a suitable allowance for each frequency present. Such an instrument has been

designed and comprises a weighting network based on Fig. 9, a valve voltmeter or amplifier and indicating instrument. The instrument, known as a Psophometer, is now in use by many administrations and

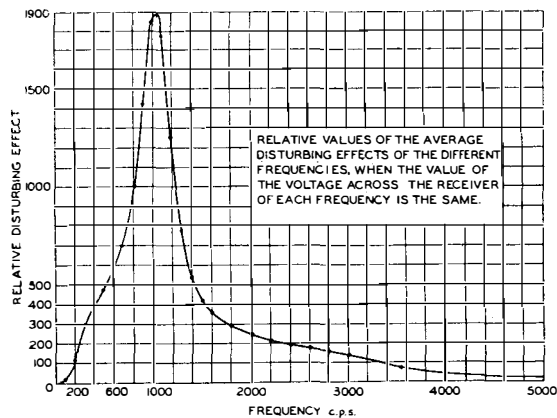

FIG. 9.—RELATIVE VALUES OF THE DISTURBING EFFECT OF DIFFERENT FREQUENCIES.

has already aroused considerable interest among power manufacturing and operating companies.

When dealing with the general principles of interference a reference was made to the fact that the residual current in a power line consists mainly of the ternary harmonic currents, as the non-ternary harmonics should balance out in the three lines. Harmonic analyses of residual currents, however, frequently reveal the presence of a certain proportion of non-ternary harmonics generally of low amplitude, due presumably to imperfect balance of the system. The use of a delta winding of sufficiently low impedance, primary, secondary or tertiary, on the line will go far to eliminate ternary harmonics from the line by providing a local path for their circulation. This precautionary step is adopted by the Central Electricity Board and is generally recognised as necessary by undertakers.

It has been pointed out that no telephone circuits even in cable are so perfectly balanced as to be entirely insensitive to noise interference, though cabled trunk circuits terminated on transformers approach closely to this ideal.

In practice it is generally found that providing the danger of high induced voltages is avoided by adequate separation, the question of noise interference arising from lines fed by large modern plant need not be closely considered. Noise interference is largely reduced by a suitable system of transpositions of the open wire telephone lines, by balanced line characteristics of the two wires and by the use of terminating equipments which are properly balanced to earth. Telephone lines must therefore be carefully constructed and maintained, and when the power undertaker's line is suspected of being the cause of interference, the first step is to make sure that the Post Office line is balanced in all respects.

Earth return telegraph lines affected by exposure to a power line over part of their length, and continued over trunk telephone routes elsewhere, have frequently caused noise interference on the telephone

lines by secondary induction. In such cases diversion has generally been adopted as the only effective cure.

MULTIPLE EARTHING.

High Voltage Networks.

With the development of the grid and its secondary lines there has been a tendency to interconnect systems and to establish ring mains.

Power systems are earthed in order to limit the stress upon the insulation and to ensure the rapid clearing of faults. A section of a large system which is earthed at one point only may be cut off from the earthing point by the operation of circuit breakers under fault conditions so that the disconnected section is left unearthed. To avoid this danger, operating authorities frequently desire to earth at a number of different stations. Research tests upon representative high voltage lines show that noise interference is not necessarily increased by multiple earthing. On the condition that steps are taken to limit fault currents, approval has already been given to multiple earthing in numerous instances, and operating experience has confirmed the results of the tests.

High voltage lines are generally built across country and close coupling with telephone routes on roads does not often occur. When it is remembered that the harmonic currents of audio frequencies spread less far afield in the earth than does the fault current of fundamental frequency, it will explain why noise interference between widely separated lines has not caused appreciable trouble.

Low Voltage Networks.

The requirements of voltage regulation, particularly where loads cannot be sufficiently well balanced between the different phases, involve the general interconnection of low voltage networks. A single earth connection on a large interconnected network fed by a number of transformers may be too remote from a fault to provide certain operation of overload protective gear. Where interconnecting switches interrupt the neutral as well as the phase conductors there is some danger that a fault will isolate a section of the network from the single connection with earth. These considerations have led to the need for earthing the neutral points of all the transformers feeding an interconnected network. Where it is particularly difficult to ensure a good earth on account of rocky or sandy soil the need for such multiple earthing is greater.

A further development of multiple earthing, new in this country, is likely to be widely adopted in rural areas where sufficiently low earths cannot be obtained for the safe earthing of consumers' apparatus. This involves earthing the neutral conductor not only at the substation but at all consumers' premises and at other convenient points. If the precautions referred to below are taken it is considered that the neutral conductor may then be safely used for earthing consumers' apparatus and that this practice will overcome the difficulty of clearing faults by ensuring the rapid operation of overload protective apparatus.

The neutral wire must be of sufficient sectional area to prevent more than a total overall drop of

50 V. in it when it is carrying a heavy fault current. It must be well earthed at frequent intervals and in addition at every consumer's premises. A suitable disposition of the earthing points must be chosen so that even with a total drop of 50 volts in it no part is more than about 30 volts above or below earth.

No part of the low voltage earth electrode system must be within the voltage gradient of the electrode used for earthing the high voltage apparatus at the substation, for this would cause all consumers' apparatus to rise to a dangerous potential above earth if a fault occurred on the high voltage side at the substation. To avoid a break in the neutral, no fuses can be tolerated on the neutral side of the circuit though links may be provided for testing.

The objections to this system are that real leakage current can no longer be measured or detected, and that by providing a neutral conductor and allowing consumers to use it for earthing a supply authority is accepting a serious responsibility and perhaps a liability gratuitously.

Effects of Multiple Earthing.

From the Post Office point of view such multiple earthing, which undoubtedly increases the flow of currents in the earth, might be expected to cause noise interference by induction and false signalling on subscribers' bells, where the bell circuit is earthed as in C.B.S. No. 1 systems. Reasonable separation of the earth plates used for the telephone installations (say 30 ft.) from earths used by the power system will generally prevent the latter trouble. In extreme cases bell adjustment may be necessary. Noise interference need not be feared in small rural systems, though its possibility must be borne in mind if the joint use of the same pole line for power and telephone circuits is contemplated.

Multiple earthing in high resistivity soils appears in some circumstances to increase radio interference, but further research is needed to show in what way.

Earth Leakage Protection.

The only safe alternative to using the neutral for earthing in areas where no large public water system exists (which is the only safe means of individual earthing) is the universal use of earth leakage switches. These devices are circuit-breakers, fitted with a tripping coil designed to operate the breaker and cut off the supply when any apparatus frame connected to them assumes, through leakage, a dangerous voltage above earth. The principle of earth leakage protection is illustrated in Fig. 10. This system, which has been largely used abroad, and to some extent in this country, is a good one, and is considered preferable from the Post Office point of view. Before acquiescing in the principle of multiple earthing described above, the Post Office has carried out very full and convincing tests. Ample evidence exists that there is little to fear. The eventual disappearance of the C.B.S. No. 1 system will remove the last remaining important objection in rural areas.

It is to be expected that our cable systems will pick up some alternating current from the earth, but as

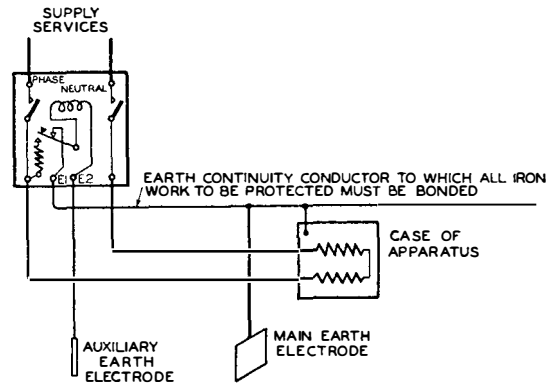

FIG. 10.—PRINCIPLE OF EARTH LEAKAGE PROTECTION, WHERE RESISTANCE OF MAIN EARTH EXCEEDS ONE OHM. THE PROVISION OF THE MAIN EARTH ELECTRODE IS NOT ESSENTIAL.

corrosion by alternating current electrolytic action is barely 2 per cent. of that caused by the same value of direct current there is little to object to on this score.

DEVELOPMENTS LIABLE TO CAUSE INTERFERENCE.

Electrode Boilers.

Another recent development is the use of electrode boilers for water heating and steam raising. Current is passed between electrodes in contact with the water and the water container is earthed.

Voltages up to 11,000, 3-phase, are commonly employed for boilers of several hundred kW capacity and smaller boilers are used on low voltage systems. The arrangement is only economical if special low rates are given at restricted hours of the day or night, and this involves the use of enormous water containers to act as thermal reservoirs.

Three practical applications of electrode boilers will be of interest.

In the first a large cotton factory in a mountainous Swiss valley is the proprietor of a waterfall, from which about 2,000 horse-power is continuously available. The power is distributed electrically in the factory during the working day and instead of running to waste for the remaining 16 hours, is converted into heat and stored as hot water in vast containers, which supply hot water and steam during the daytime for use in the factory.

In the second case a Swiss paper mill requiring heat for certain of its processes receives electrical power during off load periods at a far lower cost than would be incurred by the use of coal, of which the cost of importation and transport is very high in the remote locality in which the mill is situated.

In the third case the Charing Cross Electricity Supply Co. has installed large electrode boilers and hot water reservoirs at its Maiden Lane substation. These boilers provide a load for filling up the hollows in the power station load curve and the hot water is circulated to two theatres in the near vicinity for heating purposes.

There was some reason to anticipate that the use of electrode boilers would result in leakage currents in the earth and therefore interference, but elaborate tests on many installations have proved reassuring.

The only precaution which has been found desirable is to fix low limits for the load unbalance which can be permitted before the boiler is cut off from the supply. The normal leakage current to earth from such installations has been found to be extremely small.

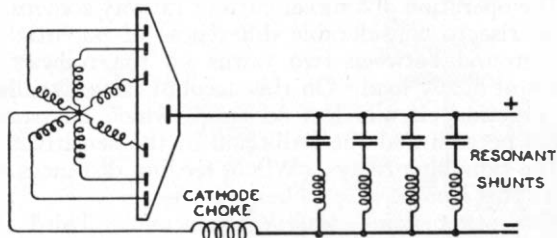

FIG. 11.—6-PHASE RECTIFIER CATHODE CHOKE AND RESONANT SHUNTS.

Low voltage electrode boilers of moderate size are also used to a limited extent, but it is not often that existing street mains are capable of supplying the heavy currents involved unless the distance from the substation is small. In these circumstances any earth leakage current will be restricted to comparatively short distances. It has also been agreed that such boiler shells shall be bonded to the cable sheath and armoring so that true earth leakage current shall be kept to a minimum.

Another form of water heater for domestic use is that in which a metallic element, heated by the current, is immersed directly in the water. Such electric geysers will shortly be available for attaching to the domestic tap, but it is to be hoped that their use will not be widespread, because in the aggregate large leakage currents may be anticipated. Obviously they could not be allowed for use with direct current.

Unless precautions are taken, dangers from shock and explosion are to be feared.

Mercury Arc Rectifiers.

The standardisation of alternating current for distribution has been largely responsible for the very important increase in the use of all types of rectifiers, not only the many small rectifiers used for commercial, industrial, and even domestic purposes, but the larger mercury arc rectifiers used for the conversion of power from A.C. to D.C., for distribution in the inner parts of large cities, where D.C. has been retained and extended. In this connection the influence of the restricted space in underground substations, and the fact that rectifiers may be remote controlled and operated in unattended substations should not be overlooked.

Rectifiers are very extensively used for new traction substations, including those supplying tramway and trolley vehicle systems, and also D.C. railways. The most important development in design is that of Grid Control, which provides a means of regulating the output voltage and has also enabled the operation of a rectifier to be reversed so that D.C. power may be converted to A.C.

This important feature has reopened the whole question of long distance transmission by means of direct current, at very high voltages.

Rectifiers are now constructed for large outputs up to 16,000 amperes, and can be manufactured for voltages up to 30,000. Their efficiency is high and fairly uniform down to one quarter of full load.

From the point of view of telecommunication interests, the extended use of rectifiers has to be watched with care, as this type of apparatus is liable to cause telephone interference due to the alternating components of important amplitude which are superimposed on the D.C. output. The output from 12-phase rectifiers usually contains large components at 600, 900 and 1,200 cycles per second, and that from the six-phase type contains a 300 c.p.s. component in addition. Many other components of higher frequencies but of relatively low amplitude are often present.

The use of a large rectifier on a relatively low capacity A.C. network may also give rise to additional harmonics on the A.C. side which may cause or increase telephone interference. These additional harmonics differ in frequency by that of the fundamental from the frequencies present on the D.C. side and therefore any of the following may appear in a 50 c.p.s. A.C. supply network:—250, 350, 550, 650, 850, 950, 1,150, 1,250 c.p.s.

If any of these harmonics are in the voltage wave form of the A.C. supply, the presence of the rectifier may increase, or in some instances decrease, their amplitude according to the phase relationships. The alternating components on the D.C. side can be materially reduced by the use of anode and cathode chokes, and more effectively by a group of resonant shunts. Four resonant shunts usually suffice for the four frequencies named. Each shunt comprises an air cored inductance and capacitance in series, carefully tuned, and shunted across the output side.

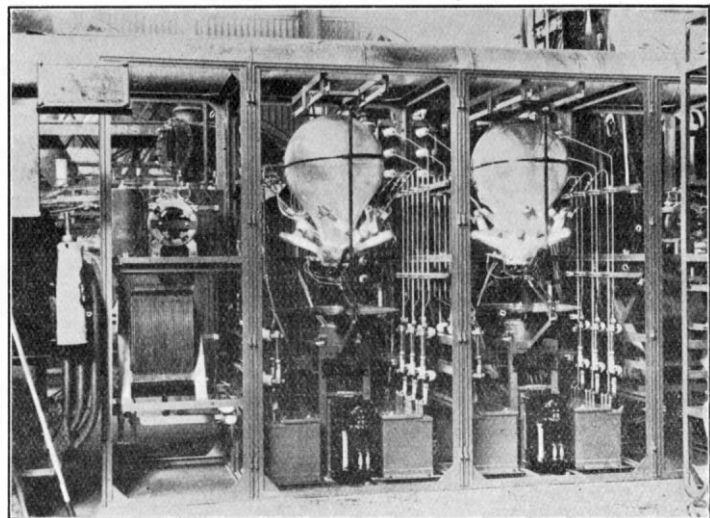

FIG. 12.—Two-BULB RECTIFIER EQUIPMENT FOR 600 kW BY HEWITTIC COY. THE SMOOTHING EQUIPMENT IS SHOWN IN THE LEFT-HAND CUBICLE.

Figs 11 and 12 indicate the method of connecting and the general appearance of a group of shunts. Unfortunately resonant shunts or other filter

circuits are expensive and certain manufacturers and users have so far shown a considerable unwillingness to provide them until they have been proved absolutely necessary in normal operation.

The number and amplitudes of the alternating components on the D.C. side are considerably higher when grid controlled rectifiers are employed and increase as the degree of voltage control is increased. The reason for this will be made clearer by a reference to Fig 13, which indicates the form of the ripple of a grid controlled 6-phase rectifier. It will

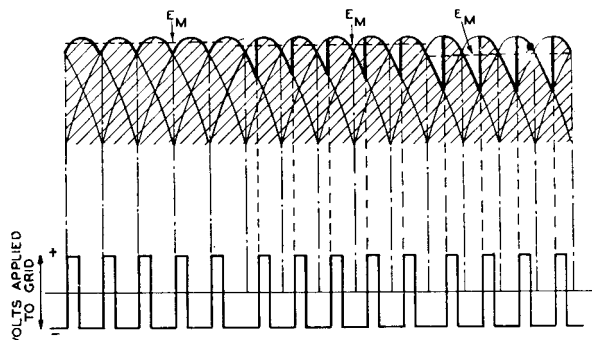

FIG. 13.—MERCURY ARC RECTIFIER. EFFECT UPON THE AMPLITUDE OF THE RIPPLE OF VOLTAGE REGULATION BY GRID CONTROL. E_M GIVES THE AVERAGE D.C. VOLTAGES CORRESPONDING TO DIFFERENT DEGREES OF GRID CONTROL.

be seen that the longer the transfer of the arc from one electrode to the next is delayed, by the A.C. potential imposed on the grid, the more distorted is the wave form.

Mercury arc rectifiers, and a variant "the hot cathode rectifier" may profoundly affect the eventual use of D.C. at high voltage for long distance transmission, a subject which is referred to later.

Direct Current Traction.

Although mercury arc rectifiers are liable to cause interference because of the alternating components in the output to which they give rise, they have at least one counteracting advantage. Being suitable for use in unattended substations it follows that it is economically possible to use a large number of small substations relatively close together. Not only does this permit the use of low voltage and third rail distribution, but feeding distances are relatively short, a circumstance which has some advantages from the telecommunication point of view.

The length of parallel between a telephone line and any section of track fed from one substation is necessarily small and both noise interference and longitudinal voltages due to transient effects, such as fault currents and their sudden interruption, will be correspondingly less important.

Short feeding distances mean low rail drop and, therefore, little leakage current to earth. For this reason there is good ground for hoping that the electrification of the main line railways will not seriously increase the Department's trouble from electrolytic action upon cable sheaths. The results of tests have been on the whole favourable, but as electrolytic

action often takes years to reveal itself, it is too early to form a definite conclusion. Wood sleepers and the well drained ballast track contribute much to reduce leakage current as compared with street tramways.

The operation of a direct current railway sometimes gives rise to considerable differences of potential in the ground between two towns on the railway at times of heavy load. On this account false signalling on junction circuits has occurred, which has sometimes necessitated the reduction of the sensitiveness of the signalling relays. Where feeding distances are short this trouble is less likely to arise.

One other point deserves mention. Third rail operation gives less trouble from transient effects than overhead contact line operation. The rate of change of current in a circuit depends upon the time constant R/L . Although the self-inductance per mile of an overhead line is about twice as great as that of a third rail system, the resistance of the former is very much lower than that of the latter. It follows that the rate of change of current, upon which the induced voltage in the telephone line depends, is far lower for third rail than for overhead contact line operation.

Street Tramways

The tramway rails are laid on a concrete bed flush with the road surface and practically uninsulated from ground so that leakage current to earth is inevitable. Moreover, the sheaths of feeder cables, tramway standards and feeder pillars are often bonded to the track and extend the uninsulated conductor to the footway.

Excessive raildrop due to badly maintained bonds and insufficient negative feeders, coupled with enormous increases in the weight, speed and number of cars in use, has greatly increased the tendency for current to leave the track for earth, and some of this current finds its way inevitably on to Post Office cable sheaths, gas pipes and water pipes. Where the current leaves the cables or pipes for earth on its way back to the negative bus-bar of the station, electrolytic damage occurs and Post Office losses from this cause are very heavy.

Trolley Vehicles.

The Post Office warmly welcomes the introduction of trolley vehicles because it is a simple matter to insulate the negative from earth at all points except at the deliberate earth at the station.

The London Passenger Transport Board has gone a step further by adopting the principle of insulating the negative as thoroughly as the positive at all points.

The one difficulty is that where guard wires are needed to prevent Post Office wires making contact with live contact wires, there is some difficulty in earthing them sufficiently well for safety. It is hardly suitable to continue as in tramway practice to connect guard wires to the negative line, which at its far end may be 120 volts about earth on heavy load, and the alternative of earthing them locally in the street

presents real difficulties. Where, however, both positive and negative lines are insulated from earth at all points as in the L.P.T.B. system, a guard wire earthed moderately well in the street affords ample

JOINT CONSTRUCTION

By this term is meant the use in common of one route of poles for the support of both telephone and power wires.

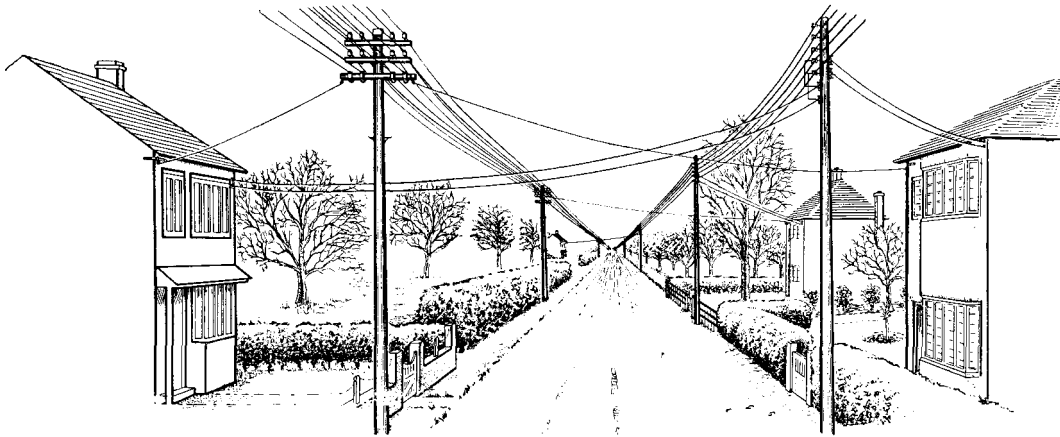

FIG. 14.- DIAGRAM SHOWING DIFFICULTY OF SERVING HOUSES FROM SEPARATE TELEPHONE AND POWER ROUTES.

protection, because if a broken telephone wire makes simultaneous contact with either the positive or negative contact line and a guard wire, the former is immediately reduced to approximately earth potential and all danger is removed.

Trolley vehicle systems are rather worse from the point of view of radio interference than tramways, and it is now the recognised practice to include radio interference suppressors on all vehicles. In difficult cases not only are inductance coils fitted in both

It is in extensive use in America, where even very high voltage lines are run on the same poles as telephone lines, more particularly where they pass through small towns and villages, but for various reasons there has been very little development in England. It is most suitable for roads where natural obstructions or local objections prohibit more than one line of poles and where the development does not justify underground cable either for power or telephone distribution.

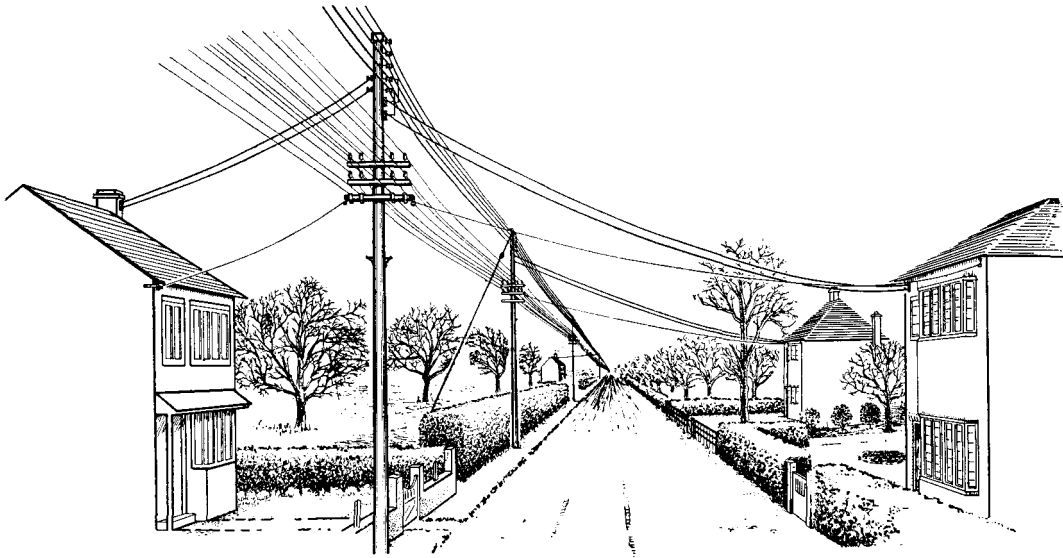

FIG. 15.- EXAMPLE OF THE USE OF JOINT CONSTRUCTION TO AVOID THE DISTRIBUTION DIFFICULTIES ILLUSTRATED IN FIG. 14.

positive and negative boom circuits, but condensers to earth from both contact wires are provided at short intervals along the route. It has also been found necessary to fit filter equipments to all items of trolley vehicle equipment liable to cause interference.

When a telephone route and a power route occupy opposite sides of a road it is not often practicable to ensure that all service lines (1) are 20 ft. above the road; (2) have a clearance of 4 ft. from the wires of the other route under or over which they have to

pass, under all conditions of sag ; (3) can be terminated on some parts of the house or bungalow to which they are run.

An attempt has been made in Fig. 14 to show how difficult or impossible it would be to meet all these conditions.

Fig. 15 indicates how these difficulties are to a great extent avoided by joint construction. It will be noticed that where the houses are very near the road, on the side on which the route is built, the clearance between power services and the telephone route must be considerably less than four feet. As, however, the wires between which the risk of rubbing contacts must be avoided are carried on the same poles and are close to their points of support, the effect of varying sag need not be taken into consideration and a clearance of two feet as a minimum would be adequate.

It will be seen that the power wires are run above the telephone wires with a clear space of four feet between them so as to give the telephone lineman adequate working space. As it is not practicable, in general, to switch off the power, the power wires and services must be insulated.

Although joint construction presents attractive features, the following considerations will indicate that it may not prove to be more economical.

- (1) Poles must be about 7 ft. taller than would be required for the telephone route.
- (2) Poles must be heavier to suit the extra loading and to provide for the higher factor of safety required by regulations for power lines.
- (3) Insulators must be interposed in stay-wires.
- (4) The power wires must be insulated conductors.
- (5) Shorter spans are used for power distribution, of 49 to 50 yards instead of the 50 to 70 yard spans used by the Post Office. More poles, arms and insulators will therefore be required for the telephone route.

When the route is of appreciable length, the risk of noise interference at such close separating distances must be borne in mind.

It is not Post Office practice to adopt joint construction with high voltage power lines and there is good reason for avoiding its use with low voltage power lines in those cases in which the latter are run elsewhere along poles carrying high voltage lines.

It is, of course, necessary to come to some agreement with the power undertaker in regard to the sharing of initial costs or in regard to rentals. Extensions and maintenance responsibilities also require catering for.

Where the anticipated telephone development makes it possible, as in some new estates, to adopt joint construction from the outset, it should prove a very useful solution, but where one authority is already *in situ* it is improbable that the subsequent advantages to be gained will be held to justify the cost of the necessary reconstruction.

TELECOMMUNICATION LINES TO POWER STATIONS.

Telephone installations in power stations and private wires between power and transformer stations for control purposes are very extensively used.

Private lines are rented from the Post Office for control purposes and are used for signalling automatically actual instrument readings, indicating the "in" and "out" positions of switches, the position of transformer taps, the number of switch reclosures still available, etc. They are also used for the remote closing and tripping of switches, for controlling tap changing gear and for the starting and stopping of rectifiers and other plant.

This development presents problems of protection for the Post Office, but has the desirable effect of making power engineers dependent upon the Post Office system, and therefore gives them a direct interest in such protective measures as will ensure the reliability of the Post Office system *in spite of* and particularly *during* fault conditions on their own system.

We must now consider what happens at a high voltage station operating with earthed neutral when a fault to earth occurs on an outgoing line. The fault current passes through the station earth electrode system, which is of appreciable resistance, and causes a drop of potential in this resistance. The electrode system and all steelwork of the building, all apparatus frames, etc., which are generally bonded to the earth electrode, are raised in potential with reference to the potential of earth at a distance from the station. A moderate fault current for a large grid station would be 5,000 amperes and, seeing that the earth resistance may be of the order of an ohm, the rise of potential of the whole station above true earth potential may be in the neighbourhood of 5,000 volts or more.

The voltage gradient is very steep close to buried metalwork in contact with the earth system, but falls off rapidly so as to disappear altogether at a few hundred feet away. This would lead to no trouble if it were not for the fact that communication lines are roughly at the potential of the earth, since they are earthed through the apparatus at the distant exchange.

All communication lines and apparatus in the vicinity of the station may be subjected to this high voltage between their sheaths or cases and the conductors inside, but the insulation provided on telephone circuits is only suitable for a pressure test of about 500 volts and would break down at 1,200 to 1,500 volts.

In this country the difficulty is overcome by complete isolation of the telephone installation from the earthed structure of the station.

Instruments are fixed in situations which are well separated from earthed metal work of the station, cable with special insulating covering is used for internal wiring, and lead-covered cable with a similar covering of rubber wax mixture for the underground portion of the leading-in cable.

The use of this type of cable is confined to places where the cable approaches within 20 ft. of any buried metal connected to the station earth system,

as, for example, power cable sheaths and armoring, within a radius of one hundred yards.

The special insulating covering withstands 5,000 volts for one minute and 15,000 volts momentarily.

Fig. 16 illustrates the extent of the danger zone around a high voltage power or transformer station.

Fig. 17 gives examples of the arrangements made to lead in telephone or control lines to high voltage power or transformer stations.

If the lead-in is overhead, the protector earth must be well outside the area over which a steep voltage gradient may be expected and a wire is run to it along the pole route, about a span distant.

Where a small private exchange exists at the station and the internal wiring to extension instruments is extensive, the latter may be carried out by ordinary methods providing the exchange line is isolated at the point of entry to the station from the internal wiring by a 1 to 1 transformer capable of

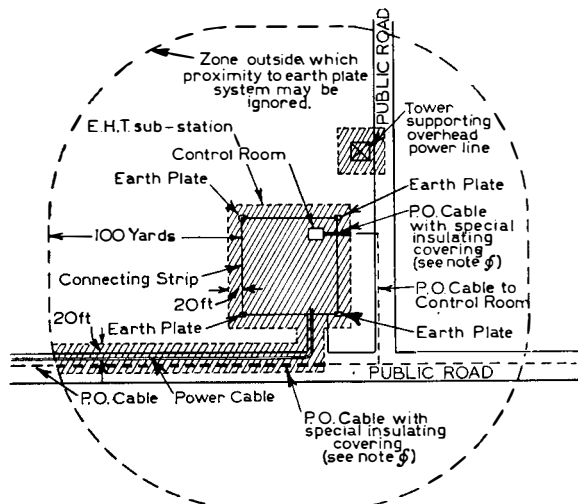

Note g. Shaded areas represent Zones in which P.O. Cable-sheaths must be specially insulated (in practice the special covering will generally extend to the nearest joint-box or manhole).

FIG. 16.—EXTENT OF DANGER ZONE AROUND H.V. POWER OR TRANSFORMER STATION.

withstanding a very high voltage between windings. In Switzerland, where dialling to an automatic exchange is in use, a special form of repeater passes the impulses inductively through the transformer, and at the exchange a relay-set is required to change them to ordinary trains of interruptions.

An alternative to the use of a transformer, in the case of single exchange lines, is to use internal wiring of a high breakdown strength and to mount the telephone in a wood cabin adequately insulated from walls and floor. The Central Electricity Board do not consider there is any danger to staff from the use of telephones because they are mounted in control rooms, usually situated outside the substation fence and outside the area of steepest voltage gradient. There is much to be said, however, for avoiding situations where the use could make good contact with earthed bodies such as steel stanchions.

Control lines are subject to conditions as to the maximum voltage and current which they may be

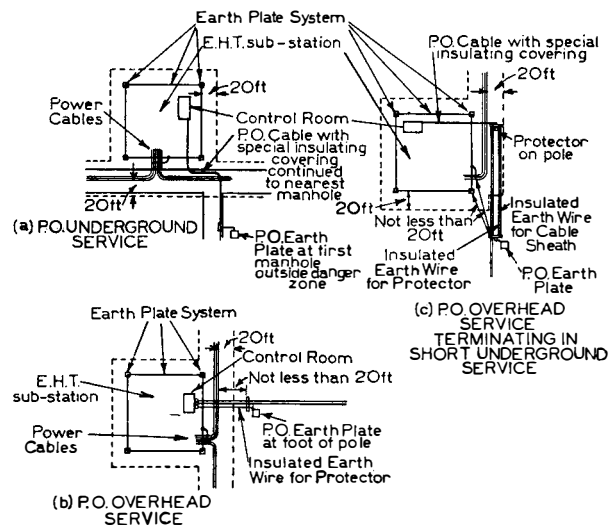

Note. Dotted line indicates zone of possible dangerous potential

FIG. 17.—EXAMPLES OF LEADING-IN ARRANGEMENTS AT H.V. POWER OR TRANSFORMER STATION.

made to transmit. Extremely careful arrangements are insisted upon to isolate these lines by means of highly insulated transformers from the instrument transformers of the power circuits to which they are linked, and special heavy spark gaps are provided to ensure that no breakdown of insulation would result in high voltage getting on to the Post Office line.

The leading-in cable and internal wiring are of the special type already referred to.

Power undertakers who have a private communication system of their own are not permitted to interconnect their system to rented Post Office lines

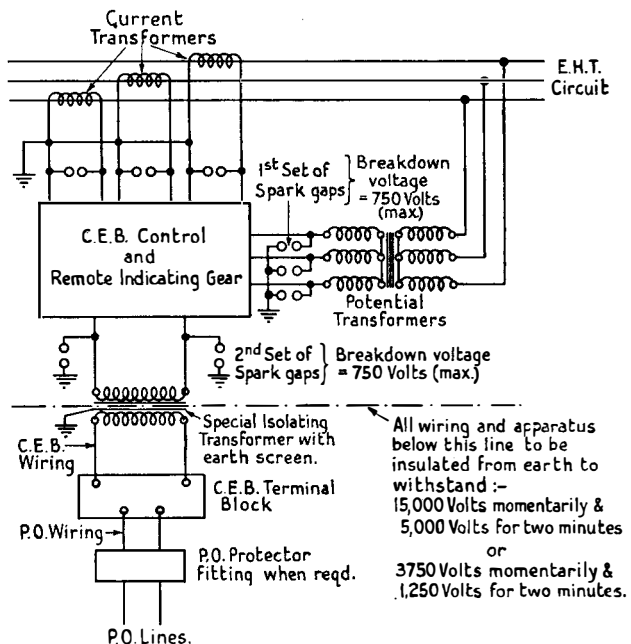

FIG. 18.—SCHEMATIC DIAGRAM OF CONNECTIONS OF P.O. LINES USED AS CONTROL CIRCUIT.

except through a special transformer of which the windings are insulated from earth and from each other to withstand a high test voltage.

Fig. 18 illustrates the means adopted for ensuring the safety of a Post Office line rented for use as a control circuit.

DIRECT CURRENT TRANSMISSION.

Owing to the heavy wattless charging currents comparable in magnitude in some cases with the load current, the distances over which power can be transmitted by alternating current are limited. An increase in operating voltage may not materially increase this range because it is accompanied by an increase in charging current in addition to an increase in dielectric and corona losses.

These considerations, together with the development of the control of rectifiers by grid potential, have focused attention once more upon high voltage transmission by direct current. This applies more particularly to foreign countries where transmission lines of exceptional length are contemplated, such as that which was proposed for transmitting by direct current at 400 kV one million kilowatts derived from water power in the Norwegian fiords through Sweden and Denmark to industrial Germany, several cabled sections over-sea crossings up to 12 miles in width being involved.

Grid controlled rectifiers would be used for converting alternating to direct current and for the still more vital problem of converting direct current back to alternating current for distribution. Large individual rectifiers are unlikely to be suitable for more than 30,000 volts, but there is no insuperable difficulty in working a number of them in series.

The economy of direct current transmission may be visualised by comparing the performance of an existing double circuit 3-phase line with 0.175 sq. in. equivalent-copper conductors, 100 miles, at 132,000 volts. This line could transmit 80,000 kW. If both circuits were operated as 3-wire D.C. circuits at 185+185 kV, *i.e.*, 370 kV between outers, the same line with the same insulators could transmit 320,000 kW.—four times as much, and with a slightly lower overall loss.

The advantages are that the insulators will withstand equally safely a much higher voltage, no wattless charging current has to be transmitted, and the copper losses and dielectric losses are lower.

The influence that such lines would have on communication lines must therefore be considered. The equivalent disturbing current in lines fed with D.C. from rectifiers is considerably greater than that associated with A.C. lines carrying an equivalent load current. The effect of earth fault currents would result in extremely high voltage impulses of short duration in parallel telephone lines.

But the most alarming feature of these projects is the avowed intention to consider using the earth

as a spare conductor in the event of one line having a fault to earth—some writers have even proposed using a single insulated line with normal return by the earth.

Such transmission lines would result in such high equivalent disturbing currents as would make it impossible to work overhead telephone lines within, for example, 1½ miles where the length of parallelism was as much as 25 miles.

The other vital matter to be considered is that of the local rise of ground potential in the neighbourhood of the earth connection, even when this is of very large proportions and is made at a depth of several hundred feet. No communication circuits could be employed having an earth of any sort within a mile or more of such an earth connection.

Further, the dangers of electrolytic corrosion would prohibit the use of bare cables within an extremely wide area.

Conclusion.

From the foregoing brief summary of the trend of power development it will be obvious that the need for co-operation with the power industry and for an intimate study of the power problems concerned has become a matter of vital importance. This co-operation is assured by the numerous committees of the Electrical Research Association on which the Post Office is represented and also by the many elaborate field tests carried out jointly by the Post Office Research Branch and the E.R.A.

Close liaison with engineers from all countries of the world is assured by the Post Office representatives at the C.C.I.F., C.C.I.T., and C.M.I. conferences. The first two study the power interference problems affecting telecommunications and decide the lines along which research is required. The C.M.I. is a joint body of power and telecommunication engineers whose function is to collect and circulate information from all sources and to organise experimental work involving the co-operation of both parties.

The tendency to make less and less use of the earth as part of a telecommunication circuit has been accompanied by a tendency on the part of power engineers to make more use of it.

The very general substitution of underground cables for long overhead lines has naturally resulted in a great improvement of lines and terminating apparatus and has therefore played an important part in solving what would otherwise have been a more formidable problem.

Interference with broadcasting, upon which so much public interest has been focused, is an entirely different problem and has barely been touched upon in this article, but it has had a certain influence in helping to demonstrate that telephone interference is not merely a Post Office problem, but a matter of public interest and importance.

A Novel System of Diplex Transmission

A. J. A. GRACIE, B.Sc., A.M.I.E.E.

Recent increases in radio telegraph traffic to ships at sea have necessitated the provision of additional channels. The author describes how this has been accomplished at the Portishead Radio Station by adding diplex equipment, thus enabling one transmitter and aerial system to transmit two messages simultaneously.

Introduction.

A FEW years ago the range of any ship transmitter was relatively small. Medium wavelengths were used and the only method of passing a message to England from a ship some thousands of miles away was for the ship to send a message to the nearest country and have it forwarded to England by cable, or to have it relayed through other ships situated at intermediate distances. The advent of short wavelength working and the discovery of the ease by which, under favourable conditions, even low powered equipments using such wavelengths could be used to effect communication over immense distances completely altered the situation, and the majority of large vessels are now equipped with short wave apparatus by means of which they are able to transmit messages directly to this country from almost any point on the seven seas. Relatively simple apparatus is usually employed, the transmitter on the ship frequently using a power of only 100 watts or even less and the receiver usually being a three or four valve set of simple pattern. All traffic is sent at hand speed. Messages so sent are received at the Post Office reception station at Burnham in Somerset and the outward messages are handled through the complementary transmitting station at Portishead.

Growth of Short Wave Traffic on Ship Service.

In order to encourage long distance ship traffic a "letter telegram" service was introduced on short waves, at very attractive rates, at the beginning of 1934, the message in such a service being sent by ships to Burnham by radio-telegraph and posted on from there to the addressee by mail. The response to this service was enormous, and within a few months additional apparatus became necessary at Burnham and Portishead to cope with the increased volume of traffic.

The "letter telegram" service is at present confined to one direction only, i.e. from ships to this country and not vice versa. It follows, therefore, that the actual number of paid words received at Burnham is considerably in excess of the paid words transmitted from Portishead, since the transmitters at this latter station are largely used to give acknowledgment of messages received or to request the re-transmission of incomplete messages. This led to a method of operation whereby three operators each with independent receivers shared the use of one transmitter, an arrangement which gave the transmitter a considerably improved load factor but inevitably gave rise to some delay in clearing traffic to any individual ship.

In order to reduce this delay without incurring the relatively heavy expense involved in the provision of additional transmitters, means were considered whereby two messages could be sent simultaneously from one transmitter. Methods of achieving this might have been to use the "Abraham" system or to employ double frequency modulation of the high frequency

carrier wave by two auxiliary low carrier frequencies, but the somewhat complicated and expensive equipment necessary for reception of signals sent on either of these systems ruled out these methods for the service in question.

New "Diplex" Circuit.

A circuit was therefore developed on the lines shown schematically in Fig. 1. Two quartz crystal oscillators having slightly differing frequencies are employed and these feed two associated amplifying valves,

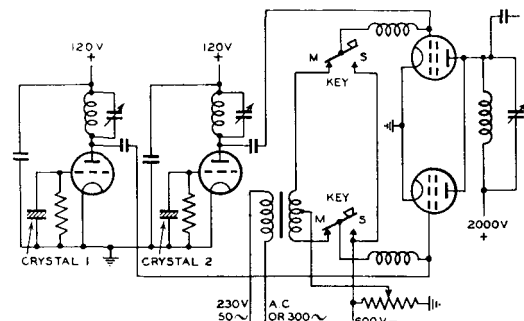

FIG. 1.—SCHEMATIC DIPLEX TRANSMITTING CIRCUIT.

the outputs of which are connected in parallel. A steady bias is fed to the grids of these amplifying valves, but superimposed on the steady voltage is an alternating voltage derived from a suitable valve oscillator. The amplitudes of the steady and A.C. voltages applied to the grids can be so chosen that during the negative half-cycles of the applied A.C. voltage the amplifying valves are rendered inoperative, but during the positive half-cycles of the A.C. voltage the valves function as amplifying devices in the normal manner. Since the A.C. voltages on the grids of the two valves are 180° out of phase, it follows that, under the above conditions, the output from one crystal oscillator is amplified during one half-cycle of the applied A.C. grid voltage and suppressed during the other half-cycle, while the output from the second crystal oscillator during the corresponding periods is suppressed and amplified respectively. As a result, two frequencies are emitted, the frequency being changed from one to the other value at a rate corresponding to the frequency of the A.C. supply impressed on the grids of the amplifying valves. If a relay is inserted in the grid of each of the amplifying valves following the crystal oscillators, by means of which a heavy negative bias can be thrown on the grid of either valve, the emission of the frequency associated with that particular valve will be completely suppressed. It is possible, therefore, by the use of such relays to send a message on either frequency by "keying" the appropriate relay. Since it is the practice in a short wave transmitter to follow the crystal-driven frequency generating apparatus by two frequency doubling stages before the output is passed to the power amplifying equipments, it follows that, if the crystal frequencies differ by, say, two

kc.p.s., the difference in the frequencies of the actual emissions radiated from the aerial will be 8 kc.p.s.

Owing to the action of the frequency doubling circuits previously mentioned, the power output from the transmitter rises rapidly as the grids of the amplifying valves associated with the crystal oscillators become less negative under the action of the applied A.C. grid voltage. As a result the envelope of the outgoing signals on either frequency is somewhat square topped. This is advantageous from the point of view of radiating the maximum amount of power, but is disadvantageous from the aspect of causing radiation over a wide band of frequencies due to the high harmonic content in such a wave form.

Initial Tests.

In order to ascertain whether signals sent by such a device could be satisfactorily received on the simple ships' receivers without mutual interference between

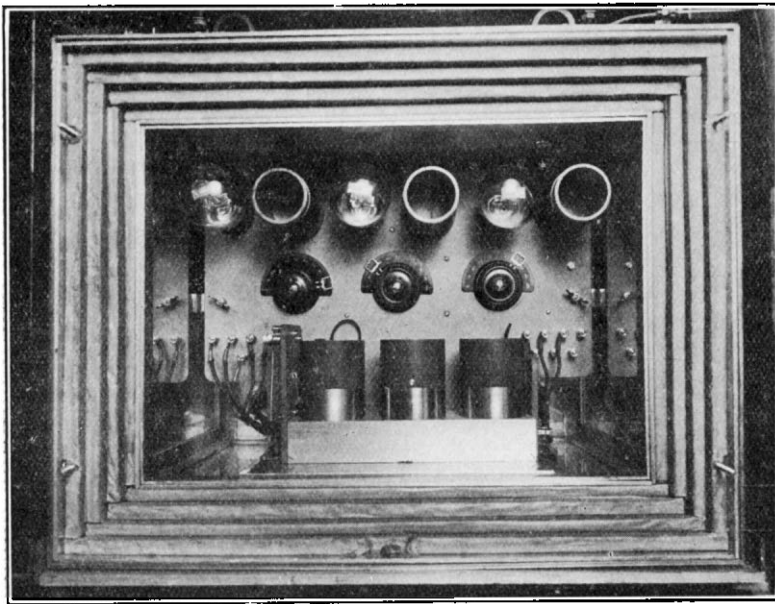

FIG. 2.—CRYSTAL OSCILLATORS.

the two frequencies employed, some preliminary tests were carried out by adapting an existing short wave transmitter at Leafield Radio Station. The A.C. grid bias utilised for frequency switching purposes was obtained from the 50 c.p.s. A.C. mains and the difference between the radiated frequencies was approximately 7 kc.p.s. The reason for employing frequencies relatively close together was two-fold: (1) because the attenuation-frequency characteristics of the later stages of the transmitter precluded the use of widely differing frequencies without undue attenuation of one or other signal and (2) because it was a simpler matter with a close spacing, to avoid interference with other services. Reception of the test transmission was carried out by a large number of ships in various parts of the world and reports were promising in-as-much as nearly all ships reported that the two messages sent out on the individual frequencies could be received without mutual interference. The main criticism was directed against the low note of the received signals due to the 50 c.p.s. modulation resulting from the switching over from one frequency to the other 50 times per second. A

further test was therefore carried out employing a switching frequency of 300 c.p.s. and in practically all cases reports of satisfactory reception of both messages were obtained. Theoretical considerations, however, showed that with the higher switching frequency there was danger that appreciable radiation might take place outside the maximum frequency band which is likely in future to be permitted by international agreement and this was confirmed by actual field strength measurements. A compromise was, therefore, struck and a decision was made to employ a switching frequency of 200 c.p.s.

Permanent Installation at Portishead.

The circuit in a slightly modified form was incorporated in a new transmitter which was in course of construction at Portishead, and commercial transmissions with the new system commenced in the early part of 1936.

Fig. 2 shows one group of crystal oscillators contained within an oven the temperature of which is maintained at a constant value by thermostatic control. Three crystals are mounted in the oven, two being of nearly the same frequency and used for duplex transmissions, the third one being a lower frequency crystal for simplex working on another wavelength. Two such ovens are provided and the crystal frequencies are such that the transmitter is capable of simplex working on wavelengths of approximately 17 and 47 metres and duplex working on wavelengths of approximately 24 metres and 36 metres, the latter wavelengths being those on which the majority of the traffic is carried.

Fig. 3 shows the crystal frequency amplifiers and the two frequency doubling stages. The top of the oven containing the crystal oscillators is just visible on the extreme bottom of the picture; in the compartment immediately above this are, at the rear, the two amplifiers, the outputs from which can be suppressed by the two keys shown in the foreground; and the top two compartments contain the frequency multiplying stages.

Fig. 4 shows a general view of the complete transmitter. The final power amplifier is equipped with two silica-envelope valves operating with a plate voltage of 10,000 volts—supplied by a glass bulb mercury-arc rectifier—and giving a high frequency power output of about six kilowatts. It is perhaps of interest to mention that all wavechanging operations can be effected, by controls mounted on the front of the transmitter, in less than two minutes.

Fig. 5 is a drawing from oscillograph traces of the rectified aerial current (a) with one duplex frequency only radiated, (b) with the other duplex frequency only and (c) with both frequencies in operation. These oscillograms were taken under "marking" conditions. Since the duration of a dot with hand speed working is approximately one-twentieth of a second, there are approximately ten pulses of power on either

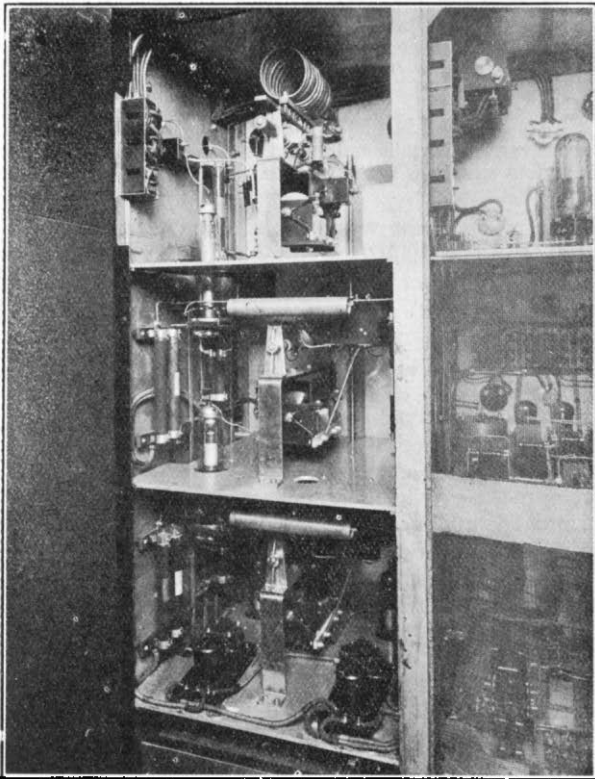

FIG. 3.—CRYSTAL FREQUENCY AMPLIFIERS AND FREQUENCY DOUBLING STAGES.

frequency during the duration of one dot. Hence variation in the total length of a dot due to the periodic complete interruption of the signal is very small. It will be appreciated of course that, under diplex conditions of working, the transmitter radiates on either frequency rather less than one-half of the total power output available from the transmitter. This is a disadvantage inherent in any diplex system and, in fact, in the system under discussion the reduction in power output is considerably less and the overall efficiency considerably higher than in the more usual

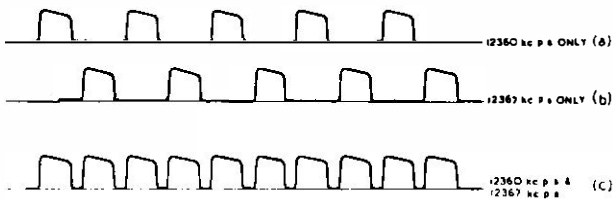

FIG. 5. OSCILLOGRAPH TRACES OF THE RECTIFIED AERIAL CURRENT.

method wherein the high-frequency carrier wave is modulated by two auxiliary low frequencies. In the radio-telegraph service to ships, the loss of power can be tolerated in the majority of transmissions ; but in order to obtain the maximum signal strength in difficult radio conditions, a key is provided on the transmitter by means of which one of the diplex frequencies can be cut out and the whole of the transmitter power concentrated in the remaining frequency. The change from one condition to the other can be effected in the course of a few seconds. The setting up of the transmitter to give approximately

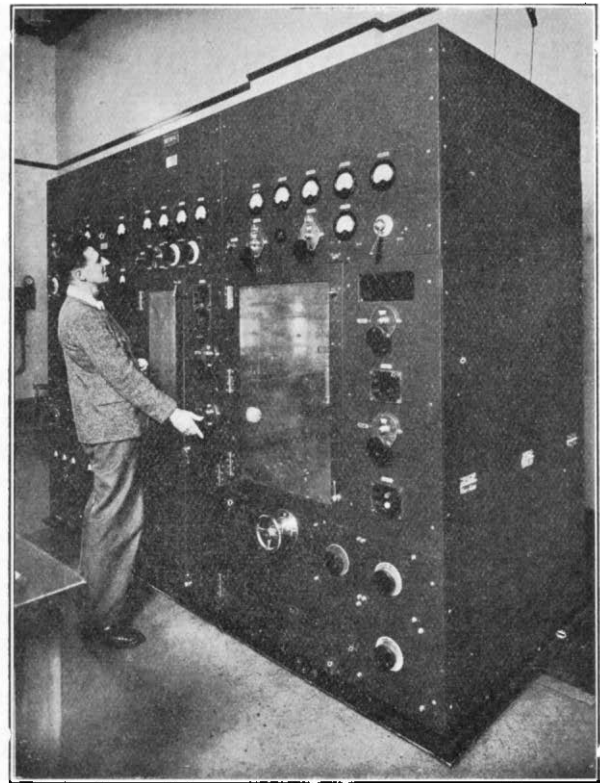

FIG. 4.—GENERAL VIEW OF COMPLETE TRANSMITTER.

the same radiated power on the two frequencies under diplex conditions has proved a simple matter as a cathode ray oscillograph was provided by means of which a visual check on the outgoing signals can be made at any time.

Results.

The system has proved remarkably satisfactory in traffic use and diplex working is employed during the majority of the twenty four hours of each day. As a result, arrangements are being made to modify another existing short wave transmitter at Portishead to incorporate the new system and when the modifications are carried out, the power output of the transmitter will be increased by doubling the number of valves in the final high power amplifier, thus compensating for the decreased period during which signals on either frequency are radiated under diplex conditions. The cost of these modifications will be very small compared with the cost of providing a completely new transmitter, and further savings, both in expense and in site requirements will accrue from the fact that the system will provide another transmitting channel without involving provision of additional aerial systems.

In conclusion, the author desires to pay acknowledgment to Mr. H. S. Robertson of the Telecommunications Department, W.T. Section, who contributed the suggestion that two crystals of slightly differing frequencies might be employed and who arranged for the listening tests carried out by ships ; and to several colleagues in the Radio Branch of the Engineering Department who participated in the construction and tests of the equipments.

The Development of Stamp-Selling Machines in the British Post Office

J. H. COMBRIDGE, Graduate I.E.E.

This article traces the history of stamp-selling machines and describes the constructional details and method of operation of the present standard mechanism. Details of cases for use in various situations are also given.

Introduction.

AN article on Stamp-selling Machines, written by Mr. H. J. Loney, appeared in this Journal in 1921¹. Since that date the number of machines in use in the Post Office has risen from a hundred or so to about 13,000 (Fig. 1), excluding the machines installed and maintained at sub-Post Offices by Messrs. Hall Telephone Accessories (1928), Ltd. The purpose of the present article is to describe the technical developments which have accompanied this expansion.

Automatic vending machines in general have for long attracted the minds of inventors, and machines for the sale of postage stamps have been no exception. The automatic sale of a small, flimsy, and sometimes sticky, article such as a postage stamp is, however, no easy matter, and although the number of inventions has been considerable, only a few of them have been capable of development as working propositions.

Among the early designs submitted to the Post Office was one which, originated in New Zealand by Messrs. Dickie & Brown, was brought to this country by Mrs. G. Kermode and later developed by the British Automatic Stamp and Ticket Delivery Co., now succeeded by Messrs. Hall Telephone Accessories (1928), Ltd. In spite of some difficulties in the early stages it was soon decided that this design showed more promise than any of its competitors, and there has as yet been no reason to alter this decision. The basic design has, however, been in a more or less continuous state of evolution, the course of which will now be traced.

INDOOR MACHINES

Submission of First Model.

The machine was first submitted to the Post Office in 1906. The original model was a coin-freed machine; that is, the insertion of a coin only freed the mechanism, which then had to be operated by raising a sliding knob. It was designed to work with a strip of stamps, not perforated in the usual way, but having a series of large holes punched for the engagement of the pins of a feeding sprocket. The stamps were to be severed by a guillotine, as is still done in certain machines in use abroad. It was decided that the machine would have to employ stamps perforated in the usual way, and this requirement was successfully met by fitting small pointed pins to the feed wheel. It was also found possible to dispense with the manual operation, since the stamps could be severed by pulling the perforations against a toothed edge. The feeding mechanism was henceforth driven by a weight which was raised in the act of inserting a coin, and was released to do its work by the fall of the coin into the cash container after it had been tested.

The first machine was tried out for a short period in 1907, and in 1908 twelve machines were hired by the Post Office for an extended trial in service, six being installed in London Post Offices and six in Post Offices in large provincial towns. The maintenance of these machines was first undertaken by the Engineering Dept. in January, 1909. After a prolonged trial with these machines an arrangement was made early in 1911 whereby the British Automatic Stamp and Ticket Delivery Co., who had taken up the development of the machines, supplied 100 pairs of $\frac{1}{2}$ d. and 1d. machines for installation in Post Offices, and received a payment in proportion to the number of stamps sold through the machines. This arrangement was continued throughout the War and until 1920.

Alterations in Postage Rates.

From the first, machines had usually been installed in pairs, one selling $\frac{1}{2}$ d. stamps for $\frac{1}{2}$ d. coins, and the other 1d. stamps for 1d. coins. When the Inland

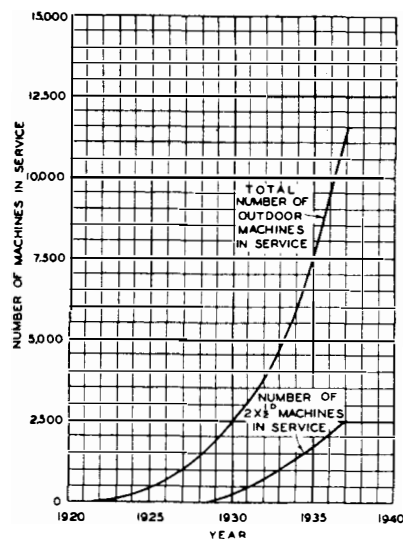

FIG. 1.—GROWTH IN NUMBER OF STAMP-SELLING MACHINES IN SERVICE.

Letter postage rate was raised to $1\frac{1}{2}$ d. in 1918, a few machines selling $1\frac{1}{2}$ d. stamps were installed. In 1920 the rate was raised to 2d., and the 1d. and $1\frac{1}{2}$ d. machines were modified to sell a 2d. stamp for two pennies. This modification of the 1d. machines was made by increasing the counterbalance weight on the escapement arm so that it required two coins to release the mechanism. While this modification was being done the $\frac{1}{2}$ d. machines were also overhauled, and it was decided to terminate the arrangement with the B.A.S. and T.D. Co., and to purchase the renovated

¹ P.O.E.E.J., Vol. XIV, p. 122.

machines. 106 pairs of $\frac{1}{2}$ d. and 2d. machines were so purchased during 1920. 30 pairs (converted to $\frac{1}{2}$ d. and 1d.) remain in use to this day, and give very little trouble.

Machines Installed Privately.

Machines were installed by the B.A.S. & T.D. Co. in public places other than Crown Post Offices under a general licence for the sale of postage stamps; machines were also installed on private premises, no licence being necessary in this case. These branches of business, as well as the sale of machines abroad, are still carried on by Messrs. Hall Telephone Accessories, who also own and maintain about 3,000 outdoor machines at sub-Post Offices, and there is no doubt that throughout the development of the machines great benefit has accrued from the manufacturer's experience of maintenance.

● OUTDOOR MACHINES

Type A.

In 1909 a pair of indoor machines was fixed to the area railings outside the branch Post Office at 294 Regent Street. (This was before Regent Street was rebuilt in its present style). The machines worked in this position with moderate success for several years. As a result of their experiences with machines fixed out-of-doors elsewhere, however, the B.A.S. & T.D. Co. developed a machine with an enclosed chamber for the stamps and feeding mechanism, in order to reduce troubles caused by dampness. The coin tester was also altered. The adoption of outdoor machines by the Post Office was delayed by the War, but in 1921 an order was placed for 240 pairs of 2d. and $\frac{1}{2}$ d. machines.

The machines purchased, later designated "Type A," are described and illustrated in Mr. Loney's article.² They were fixed in frames on the doors of Post Offices, or in cast iron cases in the front walls of Post Office buildings. Difficulties in obtaining access for loading the machines with stamps soon became apparent, especially in wall cases opening from the back, and in 1922 an attempt was made to improve matters by mounting each machine on a pivot so that the stamp chamber could be turned towards the operator for loading. In the same year the postage rate was reduced to 1 $\frac{1}{2}$ d., and the 2d. machines previously supplied were modified to sell 1d. stamps. 100 pairs of $\frac{1}{2}$ d. and 1d. type A machines are still working satisfactorily.

Type B.

After a year or two's experience with the type A machines, it became apparent that further modifications would be necessary to meet the operating conditions, which were found to be considerably more onerous than those of indoor machines. The design of an improved model was therefore started.

The difficulty in obtaining access to the mechanism for loading was lessened by substituting, in place of the hinged door, a removable sliding cover to the side and back of the stamp chamber which was enlarged to take a roll of 1,920 stamps. Changes in

the EMPTY shutter mechanism, to avoid premature operation caused by vibration and in the method of securing the feed-wheel cover, had been made on the later type A machines and were also incorporated in the type B. An effort was made to lessen the noise of operation of the machines by fitting an air dashpot to the driving weight, but this proved ultimately to be disadvantageous, as it slowed down the operation of the machine so much that coins were frequently lost by being inserted before the delivery of the previous stamp had been completed; the dashpots were removed from the machines in 1930.

The redesigned machines were introduced in 1924, and were designated "Type B," 1,500 pairs of $\frac{1}{2}$ d. and 1d. machines being purchased at various dates up to 1929.

Type B1.

In 1928 the manufacture of stamp-selling machines was taken over by Messrs. Hall Telephone Accessories, Ltd., and changes in the methods of manufacture of the machines were begun. Hitherto great use had been made of brass castings, and the working parts of the machines had been polished and lacquered in a manner reminiscent of the old forms of telegraph apparatus. The working parts were now exclusively fabricated from sheet brass stampings and nickel plate was applied to most of the parts except the face plate, which continued to be oxidised.

In previous machines the stamp roll had been placed in a rectangular well at the bottom of the stamp chamber, and the necessary tension for the retention of the EMPTY mechanism had been provided by a loose cylindrical weight. Embarrassment had frequently been caused to officers loading the machines by this weight eluding their grasp and rolling into the gutter, if not down the nearest drain. On the new design this was avoided by mounting the stamp roll on a central stud, and applying the necessary tension by an additional pin around which the stamps were led on their way to the feed wheel. The rack-and-pinion drive as used on the present-day machines was first introduced on this design, and a multiple-tooth escapement was substituted for the geared single-tooth escapement used on previous types. The method of securing the feed wheel cover was also changed again.

The design was adopted in 1929 as "Type B1." 1,000 pairs of $\frac{1}{2}$ d. and 1d. machines were purchased between the date of adoption and the end of 1931.

Machines for use on Pillar-boxes : Types C and C1.

After consideration of the requirements of a machine for attachment to pillar letter boxes it was decided that a machine should be introduced which would sell two halfpenny stamps for one penny. A suggestion to use a machine which would sell either one or two halfpenny stamps according to the coin inserted was dropped on account of the greater complication of the mechanism. In 1926 fifteen machines of the B type, but modified to sell two stamps for a penny, were purchased for a trial, and as a result of this trial an order was placed for 950 2 \times $\frac{1}{2}$ d. machines which were designated Type C1.

² Loc. cit.

The necessary changes from the B1 design to sell two stamps per coin were carried out by increasing the stroke of the driving bar, and omitting alternate pairs of teeth on the escapement wheel. Machines for the sale of two halfpenny stamps for a penny have since been manufactured alongside those for the sale of penny and halfpenny stamps for a single coin. The growth in the number of $2 \times \frac{1}{2}$ d. machines in service is shown in the lower curve of Fig. 1.

Types B2 and C2.

At the end of 1930 Messrs. Hall Telephone Accessories submitted a model in which stampings replaced the casting for the main body of the machine, leaving only the front plate and lift flap as castings. The appearance of this machine, apart from the escapement mechanism, was similar to that of the present standard machine. Machines of this design, which was identical in mechanical details to the preceding one, were introduced as types B2 and C2, and 175 pairs of $\frac{1}{2}$ d. and 1d. machines, and 100 $2 \times \frac{1}{2}$ d. machines were purchased.

Types B3 and C3.

During 1932 Messrs. Brecknell, Munro & Rogers, a firm well known in the automatic vending machine trade, submitted a machine similar to the B1 Type, but incorporating a coin tester of their own design. A feature of this coin tester was that coins were tested for over-diameter and thickness independently of the dimensions of the coin insertion slot and that under-thickness and magnetic tests were incorporated. Over-size, bent, or magnetic discs were trapped in the tester; in order to eject these without necessitating the provision of a separate press-button, the movable leaf of the coin tester was linked up to the flap over the stamp delivery aperture in such a way that the

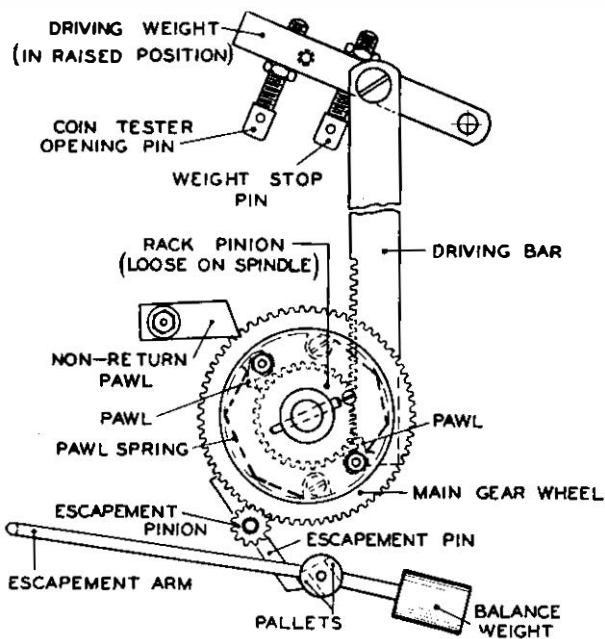

FIG. 2.—DRIVE AND ESCAPEMENT MECHANISM, TYPE B4 MACHINE.

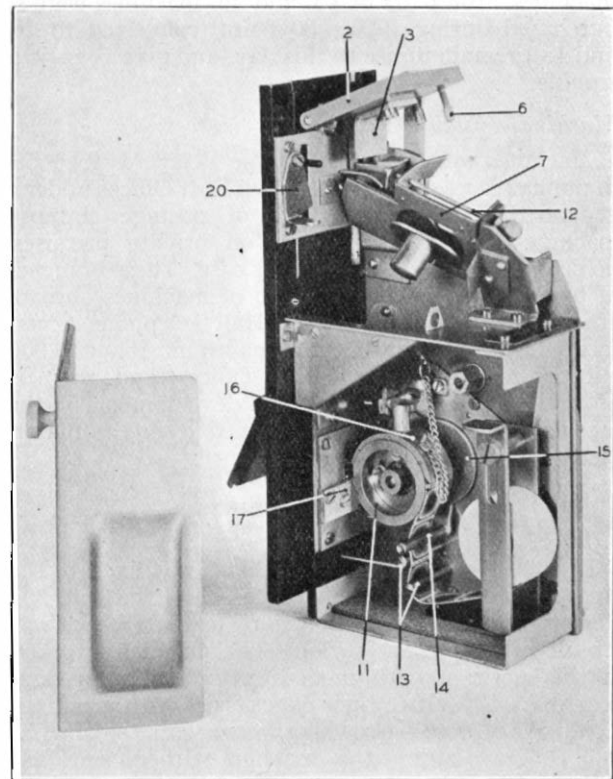

FIG. 3.—TYPE B4 MACHINE. SHOWING COIN ROLLING DOWN COIN TESTER AFTER INSERTION.

coin tester was agitated in the act of lifting the flap, thus ejecting any coin caught in the tester. Later, to avoid the ejection of good coins the action was modified to come into effect only during the lowering of the flap.

Between 1932 and 1935, 1,525 pairs of $\frac{1}{2}$ d. and 1d. type B3 machines, and 1,000 $2 \times \frac{1}{2}$ d. type C3 machines, were supplied to the Post Office. Machines of this and of modified designs have also been supplied by the manufacturers to administrations abroad.

Types B4 and C4.

As a result of their experience with the machines maintained by them at sub-Post Offices, Messrs. Hall Telephone Accessories had in the meantime come to the conclusion that the multiple-tooth escapement was not as satisfactory as the old type of geared single-tooth escapement as used on the Indoor, A, and B machines. They had therefore developed from the B2 a modified design incorporating a geared escapement, but retaining the rack-and-pinion drive, as shown in Fig. 2.

The new machine incorporated ball bearings for the main spindle and various other improvements, and was introduced by the Post Office in 1935 as the B4 type, accompanied by the C4 with the appropriate gear ratio for the sale of two halfpenny stamps for a penny. Various changes, mostly of a minor character, have since been made, and this machine has now been adopted as a Post Office standard, full manufacturing drawings having been prepared by the Department, in collaboration with Messrs. Hall, for use in the

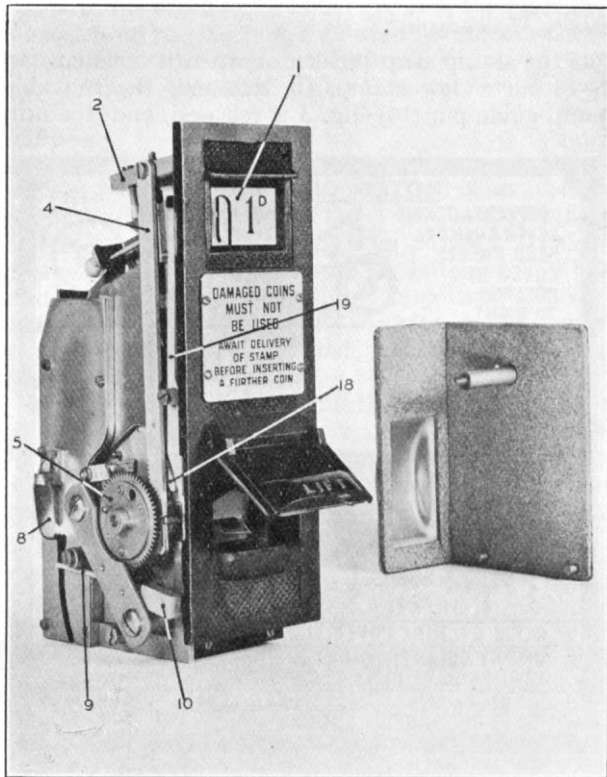

FIG. 4.—TYPE B4 MACHINE. AFTER DELIVERY OF STAMP.

manufacture of future supplies. "Standardisation" is not intended to prevent further changes, should these be found desirable, but will ensure that further changes are introduced in a systematic manner, without upsetting the performance of the machine in other directions, and so far as possible without affecting interchangeability of parts for maintenance purposes. A recently manufactured machine is illustrated in Figs. 3 and 4.

OPERATION OF TYPE B4 MACHINE

Drive, Coin Testing and Escapement.

As the coin is inserted it slightly raises the EMPTY plate (1) Fig. 4, which overlaps the coin slot by a small distance, for a reason that will be explained later. It then lifts the driving weight (2) Fig. 3 by means of an angle-piece (3) fixed to its lower surface. The work in these operations is performed by the intending purchaser of a stamp. During the lifting of the weight the rack cut on the driving bar (4) Fig. 4 rotates the rack pinion which is loosely mounted on the main spindle, and the weight is retained in its raised position by the engagement of one of the pawls mounted on the inner face of the main gear wheel (5), which at this stage is held stationary by the escapement mechanism. Lifting of the weight removes the Coin Tester Opening Pin (6) Fig. 3 from engagement with the overhanging arm of the coin tester (7) and allows the latter to fall into position to receive the inserted coin.

After raising the weight the coin is allowed to fall over to an angle of about 20° from the vertical, and in this position it rolls down the coin tester, its upper edge being supported by the coin test rail, see Fig. 5. The edge of an under-diameter coin or disc will pass beneath the coin test rail, which is pivotally mounted to prevent jamming, and allow the coin to fall over so far that its lower edge cannot rest on the bottom rail of the coin tester, which is made narrow at the appropriate point, so that the coin drops down into the reject shute, and is returned to its owner via the well of the stamp delivery cavity.

A coin which passes the coin tester correctly falls down a vertical shute on to the end of the escapement arm (9) Fig. 4, passing on the way a pawl (8) fitted to prevent the withdrawal of any disc which may be secured on a thread or wire. Provided that its weight is near the correct value it depresses the arm, and the first pallet permits the escapement pin to pass, with a small rotation of the gear wheels.

The coin then leaves the escapement arm and falls to the cash till, and the escapement arm is returned to normal by the counter-balance weight (10), removing the second pallet from the path of the escapement pin. This allows the wheels to revolve under the force transmitted from the driving weight through the rack, pinion and pawls, see Fig. 2. The main gear wheel completes its step of one-sixth of a revolution carrying with it the main spindle and feed wheel (11) Fig. 3, and the driving weight returns to normal. On C4 machines the step is required to be one-third of a revolution and the gear ratio is designed accordingly. At the end of the fall of the weight, the Coin Tester Opening Pin strikes the arm of the movable part of the coin tester, and rotates this part on its spindle (12) in order to remove it from below the coin slot, so that any rubbish subsequently inserted will fall straight to the reject shute.

Feed and Delivery.

The roll of stamps is supported on a rotatable stud, and the stamp strip passes round two fixed guide pins (13) Fig. 3 and then behind a pin (14) mounted on a pivoted arm (15); this arm actuates the

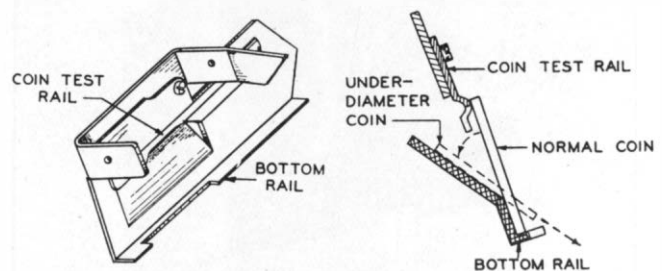

FIG. 5.—COIN TESTER.

EMPTY mechanism, to be described later. The strip then runs on to the feed wheel (11) from circumferential ribs on which small pointed pins project radially, as shown in Fig. 6, to engage with two perforations in each row. To emphasise the need for care when loading the machine with stamps, an

etched brass plate with notes and sketches as shown in Fig. 7 will be fixed on the stamp-chamber cover of the standard machines.

The strip is held in position by the feed wheel cover (16) Fig. 3, the under surface of which is grooved for the passage of the pins just referred to. On previous machines the weight of the cover rested on the stamps, but on the B4 and C4 types it is transferred to the flanges of the feed wheel by projecting pins at the sides of the cover, the object of this arrangement being to reduce the sticking of the stamps to the feed wheel in wet weather. The cover is expanded during manufacture to a slightly larger radius than the feed wheel, and the clearance dimension, also the degree of freedom allowed to the cover, are critical factors in the correct functioning of the machine.

When the feed wheel rotates one step, a stamp (or on C4 machines 2 stamps) is projected through the delivery slot by the peeler (17) Fig. 3, which has curved fingers passing either side of the ribs on the feed wheel, as shown in Fig. 6. The rotary position of the feed wheel with relation to the escapement mechanism is so adjusted during manufacture that the perforations behind the delivered stamp come beneath the sharpened teeth of the tearer, which is fixed to the front of the feed wheel cover. One or more stamps

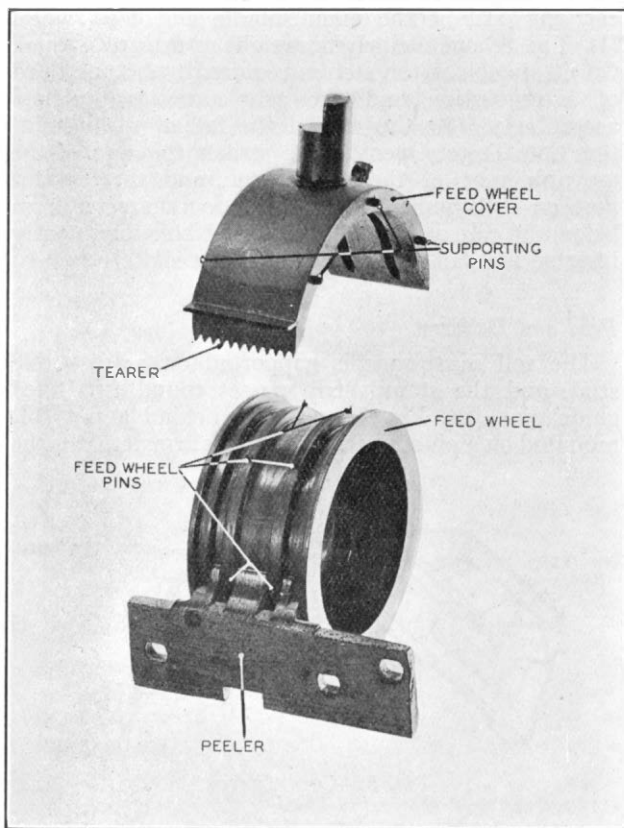

FIG. 6.—FEED WHEEL AND ASSOCIATED PARTS.

may be purchased before being torn off. The shape of the peeler and associated parts is such that when the delivered stamp is pulled it is severed at the perforations by the teeth of the tearer.

Empty Mechanism.

If the stamp strip breaks, or when it is exhausted to within a few stamps of the end, the movable stamp guide pin (14) Fig. 3 is released, and the arm

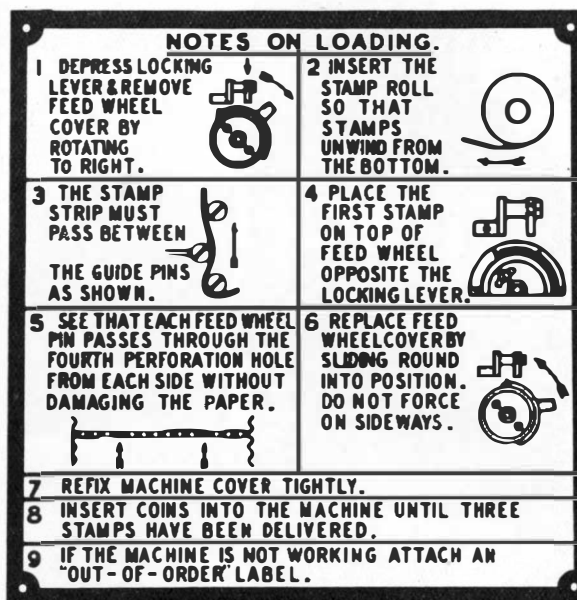

FIG. 7.—LOADING INSTRUCTION PLATE.

(15) on which it is fixed falls under gravity. A cam (18) Fig. 4, on the other end of the spindle on which the arm is fixed, then rests against the lower end of a vertical lever (19) pivoted near its middle, the notched upper end of which supports the EMPTY plate (1). Upon the insertion of the next coin the EMPTY plate is raised slightly, and the lever (19) then swings clear and allows the plate to fall after the coin has passed. The plate is retained in its lower position by a latch (20) Fig. 3, and bears the word EMPTY on the part which now covers the coin slot. On the part which is normally in view is marked the denomination of coin by which the machine is operated—this can be seen in Fig. 4. The EMPTY plates on B4 and C4 machines are vitreous enamelled in black and white for better visibility in partial darkness.

CASES AND MOUNTINGS

Types A, B, C and D.

Various methods of mounting outdoor machines had been used before the machines were taken up by the Post Office. Some of them provided for a posting box in the same structure as the machine housing.

The first machines used by the Post Office, except those mounted in doors and windows, were fixed in cast iron cases built into the front walls of Post Offices and accommodating either one or two machines. In cases types A and C the front was hinged, whereas in types B and D the front was fixed and access to the machines was reached by a door at the back.

Objections were raised to these cases on the grounds that their large size interfered too much with the structure of the building. At the same time adequate

access to the machines was not given in the cases that opened from the back, and efforts to improve matters by mounting the machines (type A) on pivots were only partially successful. These cases are now obsolete.

Type E.

For mounting in windows or doors a brass mounting plate or frame was used. This was fixed in an aperture cut in the door, or in a wood panel fixed in the window, and the machine was clamped in position by metal clamps at the top and bottom. Later the bottom clamp was replaced by a rectangular well cast integrally with the frame in order to prevent water getting in at this point, and the mounting in this form is widely used at the present time.

When possible, this mounting is also used for machines fixed in walls, a special aperture being cut in the wall to receive a wooden panel to which the mountings are secured; the machines are reached from the inside of the building.

Type F.

When the type B machines were introduced, an effort was made to meet the difficulties in loading,



FIG. 8.—F TYPE CASE.

while keeping the dimensions of the case small, by introducing the type F cast iron case, shown in Fig. 8. As will be seen, the machines are mounted on separate doors opening downwards. The coins are conveyed to the inside of the office through metal tubes from below the machines in order to avoid deepening the case to accommodate cash tills.

Type K (Fig. 9).

This case was designed in 1930 for use in railway stations. It has recently been used extensively in open-air situations generally. Two machines are accommodated, with cash tills below, and the case can be fixed to or in a wall, or on a pedestal as shown in the illustration.

Types H, J, L, M, P and Q.

These cases were introduced to house the $2 \times \frac{1}{2}$ d. machines attached to pillar boxes. Types H and J



FIG. 9.—K TYPE CASE.

were the first produced, but were later superseded by types L and M, which are similar to the former, but with larger cash containers. Types L and M are illustrated in Fig. 10; the two types are identical in



FIG. 10.—L OR M TYPE CASE.

design, but are fitted with differently curved packing castings for adaptation to the two standard sizes of pillar-boxes. Types P and Q are for fixing to the left-hand sides of pillar-boxes; the machines in these cases are fixed to doors opening downwards, as a side door would not give access to the stamp chamber, which in these cases faces the body of the pillar-box.

Type R.

This is a self-contained case for a single machine, suitable for building into a wall. It is formed by fixing a flat side plate to the body of a P or Q case, in place of the casting normally used to conform to the curvature of a pillar-box.

ACCESSORIES

A number of accessory items has recently been introduced to improve the service given to the public by stamp-selling machines. Apart from explanatory and cautionary notices regarding the working of the machines, the most interesting of these are the following :—

Hoods.

The effect of dampness on the working of the machines is sometimes serious. Even when actual stoppage of the delivery is not caused by the sticking up of the stamp roll or by the adhesion of stamps to the feed wheel, difficulties in the operation of the feeding mechanism may be caused which lead to the stamp strip getting out of register with the feed wheel pins, and so resulting in the delivery of torn stamps. Although it is probable that condensation causes a portion of the dampness trouble, there is no doubt that in many instances the cause is the entry of rain into the machine. To minimise this trouble small

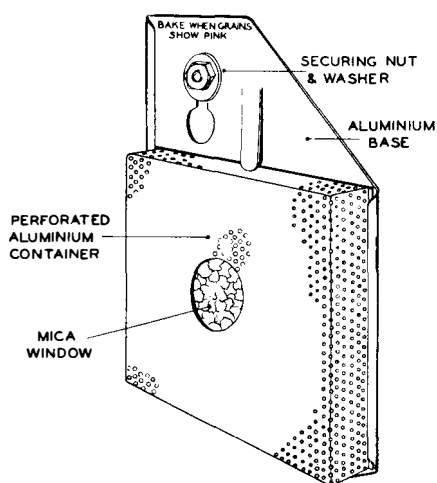

FIG. 11.—SILICA GEL DEHYDRATOR.

hoods will in future be fitted over machines on exposed sites. The hoods have glass tops to allow light to fall on the coin slot and project about 3 inches in front of the machine face.

Silica Gel Dehydrators.

Under favourable conditions dampness in the stamp chamber, whether due to condensation or otherwise, can be absorbed by silica gel. This method is not successful where the quantity of moisture is great, but its non-success in such an instance should serve to call attention to the need for an improvement in the protection of the machine from adverse conditions. Trials with a small dehydrator, consisting of a container of perforated aluminium, having a mica window and filled with silica gel, have shown some success, and a further provision of these items is to be made. The silica gel used is impregnated with a cobalt salt which shows dark blue when the gel is dry and pink when it is saturated. The complete container (Fig. 11) is baked in a domestic oven for a few hours to expel the absorbed moisture from the gel, and is then ready for re-use. When in use it is fixed to the inside of the stamp-chamber cover opposite the position occupied by the stamp roll.

Heating Devices.

The use of a heating device provides an apparently satisfactory, if expensive, means of combating dampness caused by condensation. An interesting example is at Princetown, on Dartmoor, where in foggy weather the Sub-Postmaster uses a small oil lamp to protect the machines, which in this case are the property of Messrs. Hall. Several installations in various parts of the country have been fitted with electric lamps for heating purposes. A 15 W lamp hanging between the two machines of a pair, and either left permanently in circuit or switched on in damp weather, has been satisfactory. Experiments are now in progress to find whether sufficient heat is given by a 10 or 5 watt lamp, and if satisfactory the use of the remedy may be found economical where electric supply is available.

Out-of-Order Labels.

When a machine is faulty, it is desirable to prevent the insertion of further coins at once, pending removal of the fault. This is done by fixing an Out-of-Order label over the coin slot. The improved labels now being introduced have a specially-shaped lug which is inserted in the coin slot and is automatically clipped in position by the small amount of lift and fall normally provided for the EMPTY plate of the machine. It has recently been decided to engrave the words "NOT IN USE" in place of "OUT OF ORDER" on the labels, which are of brass, copper-oxidised.

Testing Rolls.

In order to give the maintenance staff a reliable means of testing the machines, it has been found necessary to use dummy stamps printed with an arbitrary design, as the blanks previously used behaved differently in the machines, apparently due to the different coefficients of friction of plain and printed paper. The machine shown in Fig. 3 is loaded with dummy stamps.

STAMP BOOKLET MACHINES

2/- Booklet Machines.

In 1931, 25 machines for the sale of 2/- stamp booklets were installed experimentally in the public offices of important Post Offices. These machines were operated either by a florin or by two separate shillings. Difficulties were experienced from the large numbers of florins in circulation of various Victorian issues, the dimensions of which were different from the present standards; it was also found that the large value of the items sold tempted the makers of spurious coins, at the same time making the owners of good coins somewhat cautious lest the machine should fail to deliver the goods. The popularity of the machines was small and they have now been withdrawn from all but a few of the busiest sites.

6d. Booklet Machines.

An experiment is now in progress with outdoor machines for the sale of booklets to the value of 6d. The experimental machines are of types familiar in use for the sale of cigarettes and sweets. Twelve machines have been fixed at various sites in London to test the public's reaction to a machine of this denomination, and if this is favourable the adaptation of the design to meet Post Office requirements will be proceeded with. Obviously the booklets may be

made up of stamps of any desired combination of values. Those in use for the trial consist of two leaves each of two 1½d. stamps, stitched between two card covers, and the overall thickness is about 0.035 in.

CONCLUSION

Although the main work of the Post Office Engineering Department is concerned with the telephone and telegraph services of the country, there is a rich field in the application of engineering methods to the postal services, not the least important of which is the 24 hours' sales service of stamps. There is, in fact, a large proportion of the general public whose good opinion of the Post Office depends in the maintenance of a high grade of service on stamp-selling machines. Every effort has been made in the design of the machines to ensure reliability of action, but a first-class service can only be achieved if the staff responsible for its maintenance are thoroughly trained in the work and apply themselves to it with the enthusiasm and diligence they display in the maintenance of the telephone and telegraph services.

The author wishes to express his thanks to the Director of Postal Services and the Engineer-in-Chief for permission to make use in this article of information from official records, and to Mr. F. W. Hall for the verification of historical details.

TELEGRAPH AND TELEPHONE PLANT IN THE UNITED KINGDOM TELEPHONES AND WIRE MILEAGES. THE PROPERTY OF AND MAINTAINED BY THE POST OFFICE IN EACH ENGINEERING DISTRICT AS AT 31st DECEMBER, 1936.

Number of Telephones	Overhead Wire Mileages.			Spare	Engineering District	Underground Wire Mileages			
	Telegraphs	Trunk	Exchange*			Telegraphs	Trunk	Exchange†	Spare
1,023,662	379	3,535	53,366	7,668	London	37,620	290,760	4,078,374	79,606
126,048	1,771	13,243	54,212	9,547	S. Eastern	6,370	122,080	405,111	51,805
151,563	2,868	33,928	103,229	8,395	S. Western	25,528	94,531	319,506	107,511
105,122	3,336	35,707	87,379	15,619	Eastern	15,976	102,764	205,699	71,480
120,685	3,348	29,169	65,221	20,791	N. Midland	5,664	196,569	260,332	79,404
129,391	1,820	19,590	79,083	17,041	S. Midland	10,086	158,724	363,544	63,854
85,611	1,682	24,297	72,629	10,938	S. Wales	6,947	89,884	172,846	67,536
171,716	2,976	17,050	72,497	18,644	N. Wales	10,341	165,470	494,156	89,525
212,152	1,061	3,450	31,847	8,076	S. Lancs.	8,166	144,640	737,899	57,132
92,430	837	7,474	35,004	18,618	N. Western	6,780	122,654	272,130	62,932
35,881	2,971	11,347	16,957	1,342	N. Ireland	412	8,893	91,863	20,190
255,832	5,053	36,535	88,244	23,206	N.E. Region	16,553	256,046	699,890	122,267
237,153	6,795	45,218	98,874	20,917	Scot. Reg.	12,585	212,591	494,988	106,744
2,747,246	34,897	280,543	858,542	180,802	Totals	163,028	1,965,606	8,596,338	979,986
2,650,299	35,706	288,533	832,238	177,069	Totals as at 30 Sept., 1936	161,106	1,863,669	8,526,223	981,324

* Includes low gauge spare wires (*i.e.*, 40 lb. in open routes and 20 lb. or less in aerial cables).

† Includes all spare wires in local underground cables

The C.T.O. Inland Phonogram and Telephone-Telegram Installation

T. E. HOGG and J. SHARP

A description is given of the phonogram and telephone-telegram equipment recently installed in the Central Telegraph Office, London, which is believed to be the largest installation in the world for this class of service.

Introduction.

THE provision of the installation described completes another step in the comprehensive reorganisation of the phonogram and telephone-telegram sections of the Post Office telegraph system, undertaken as a result of the recommendations of the Simon Report.¹ It allows the replacement of morse systems by telephone working on short distance circuits of low traffic capacity, and provides a central point for the dictation of telegrams by and to telephone subscribers over the telephone network.

As there may be some doubt as to the distinction between the terms, Phonogram and Telephone-Telegrams, these are defined below:—

Phonogram. A phonogram is a telegram which is transmitted by telephone, between a post office and a telephone subscriber.

Telephone-Telegram. A telephone-telegram is a telegram which is transmitted by telephone, between two post offices.

In the C.T.O. the received phonograms and

by asking the local exchange for "telegrams." Telephone subscribers in automatic areas gain access to the Phonogram section by dialling "Tel." and subscribers in manual areas ask the local exchange for "telegrams," the calls being completed over direct junctions or via Tandem. A number of junctions has been provided between Tandem and the C.T.O. for the purpose of carrying this traffic.

Outgoing telephone-telegram traffic from the C.T.O. is disposed of over the direct telephone-telegram circuits, or via the exchange system, to post offices for delivery in the respective areas. Out-going phonogram traffic is disposed of by dialling the required subscribers direct, or by obtaining them via manual exchanges where necessary, and then dictating the telegram over the circuit.

Unlike telephone exchange work, where an operator is required to spend only a relatively short time on each call, the handling of a phonogram, or a telephone-telegram, occupies the undivided attention of the operator for an appreciable and widely variable period of time. It was therefore necessary to take into account this factor, as well as the incidence of calling, when determining the equipment required to maintain a reasonable standard of service.

Equipment provided.

The main equipment is of the standard, double tier, continuous panel type,² and the whole of the installation work with the exception of the Vee belt conveyors was carried out by the local Post Office engineering staff.

The telephone-telegram equipment comprises six suites of sixteen positions each, with a 5-panel multiple appearing four times on each suite. In addition, there are four suites of deconcentration positions, each suite having fourteen positions. Any one of these positions can be connected to a selected telephone-telegram circuit by means of plugs and cords at a deconcentration switchboard. There are also two distribution positions, which facilitate the distribution of messages that have to be forwarded

over the direct telephone-telegram circuits.

The phonogram equipment comprises twelve suites of sixteen positions each, making a total of 192 phonogram positions in all, with a 5-panel multiple appearing four times on each suite.

A general view of the phonogram suites appears in Fig. 1. A 12-position suite handles all enquiry



FIG. 1.—GENERAL VIEW OF PHONOGRAM AND TELEPHONE-TELEGRAM SUITES.

telephone-telegrams are typed down direct from verbal dictation.

Where the traffic and economic conditions are favourable, direct junctions, known as direct telephone-telegram circuits, are provided between the C.T.O. and certain post offices. Where direct telephone-telegram circuits are not provided, the post office gains access to the C.T.O. telephone-telegram section by dialling "C.T.O.," or, in manual areas,

¹ "Modernising the Telegraph Service," A. O. Gibbon, *P.O.E.E.J.*, Vol. 25, Page 25.

² The standard arrangements and circuits for this type of equipment were covered in "Modern Developments in Phonogram and Telephone-Telegram Working," G. Spears, *P.O.E.E.J.*, Vol. 26.

work in connection with the phonogram and telephone-telegram traffic. A portion of this suite can be seen on the left of Fig. 1.

Foot switch transmitter cut-outs of the non-locking type are fitted on the floor at each position. The operators are thus able to make full use of this important facility while using both hands for typing. Single stage amplifiers, for increasing the strength of received speech, are associated with each position.

A Vee belt conveyor below the centre of each suite of positions carries the received messages to their appropriate circulation points.

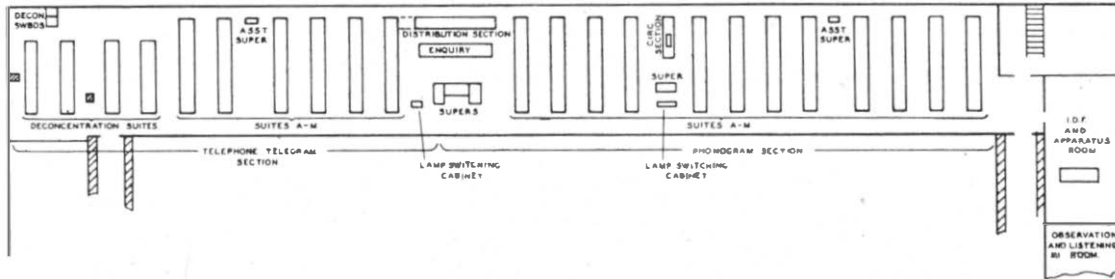

FIG. 2.—GENERAL LAYOUT OF EQUIPMENT.

The remainder of the equipment consists of one listening-in position, two observation positions, three supervisors' desks, two supervisors' panels and five ancillary switching cabinets.

The accessory apparatus is in a separate room, so that noise from the relays, switches, etc., may not give rise to hearing difficulties in the phonogram room.

Accommodation.

In view of the number of operators to be accommodated in the one room and the fact that type-writer reception was to be adopted, a high room noise level was anticipated. To counteract this the whole of the ceiling of the phonogram and telephone-telegram room was treated with sound absorbing material, and the results amply justify this precaution. The general layout of the equipment, which occupies the whole of the West Gallery and part of the North Gallery on the fourth floor of the building, is shown in Fig. 2.

Cabling.

The Traffic Department expressed a desire for concealed cabling between the suites and the accessory apparatus, etc. This involved the provision of cable chases in the floor, and as the existing floor was not sufficiently deep to accommodate the required number of cables, a new floor six inches deep was built over the old one. The work of providing the chases was proceeded with concurrently with the building of the new floor. The chases, which extend down the whole length of the West Gallery, are lined with sheet metal, and have removable metal covers.

Owing to the long distance between the apparatus room and the suites of positions it was decided that the cables connecting these two points should be paper insulated. These were tail-ended with silk and

wool cable. The use of lead cables made it necessary to provide a terminating point so that connection could be made to the switchboard cables feeding the jacks, lamps, etc., on each suite. This was conveniently done by mounting connection strips on a small iron frame designed to fit beneath the end of each double table.

Telephone-Telegram Cord Circuit.

The whole of the cord circuit apparatus, excepting the keys, plugs and lamps, is contained in an auxiliary apparatus unit of the "jack-in" type, known as

"Unit Auxiliary Apparatus TL 1643." In Fig. 3 two of the units can be seen in position under the desk. The cover has been removed from one of them so that the arrangement of the relays, etc., may be seen. The foot switch transmitter cut-out can be seen immediately beneath the right-hand unit. The transmission portion of this circuit is the well-known Stone system of cord circuit feed. On short direct telephone-telegram circuits the current for the operation of a distant transmitter is supplied from

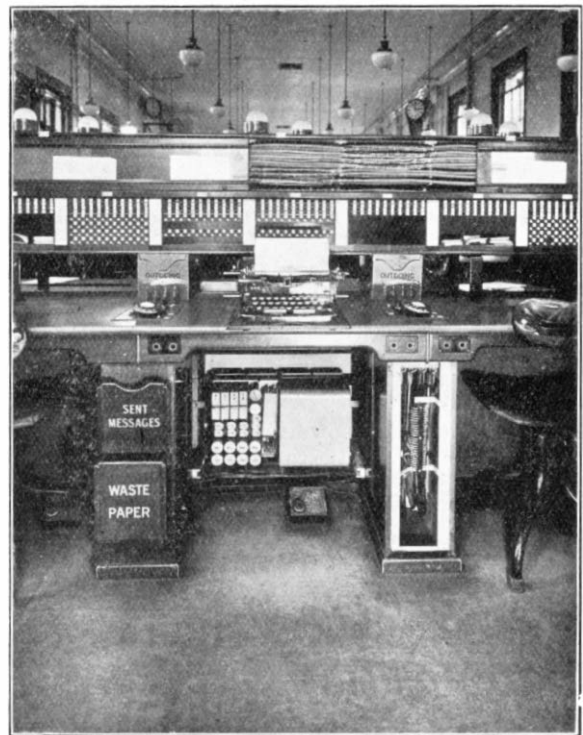

FIG. 3.—TELEPHONE-TELEGRAPH POSITION

the telephone-telegram cord circuit. For this reason it is essential that, when using a battery of 22 or 24 volts, the combined D.C. resistance of each cord circuit feed shall not exceed 100 ohms. This cord circuit is used in conjunction with the distribution positions, and as the arrangement is somewhat exceptional it is proposed to describe it rather fully.

Distribution Positions.

Each distribution position consists of a panel having a field of position lamps and a field of circuit busy lamps and circuit keys. The keys are of the push button type. A photograph of one of the positions appears in Fig. 4. Each position lamp is associated with a particular telephone-telegram position, and is designated with the number of that position. Each circuit busy lamp is associated with a particular direct telephone-telegram circuit, and is designated

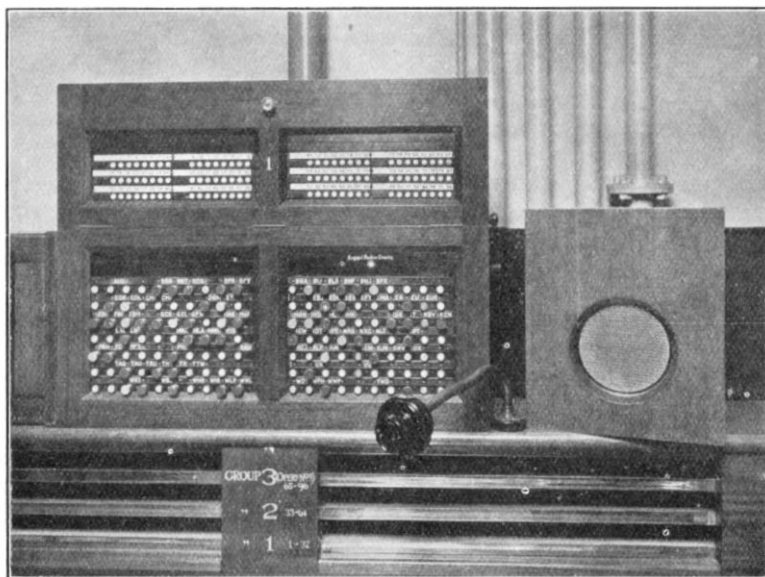

FIG. 4.—DISTRIBUTION POSITION.

with the code of that circuit. A circuit key is associated with and fitted immediately below each circuit busy lamp, the key being labelled with the same circuit code as the lamp with which it is associated. The panels are adjacent to a conveyor drop point where messages are received for forwarding over telephone-telegram circuits.

The facilities provided by the distribution positions are :

- (1) Visual indication of all direct telephone-telegram circuits that are engaged with incoming or outgoing traffic.
- (2) Visual indication on the operation of a circuit busy key of the number of the position which is engaging that particular direct telephone-telegram circuit.
- (3) Visual indication to the engaging position operator that a further message is being circulated to that position for transmission over the circuit which is engaged there.

The circuit is shown in Fig. 5, and a brief description of its operation follows.

When the calling plug of a telephone-telegram position cord circuit is inserted into the outgoing jack of a direct telephone-telegram circuit the line circuit K relay operates. Contact K 3 lights the circuit busy lamp associated with this circuit on the distribution panels. Cord circuit relays HC, HCC, HD and HDD operate. Contact HDD 3 operates relay I, which at contact I 2 prepares a circuit for the lighting of the circuit lamp on the position keyboard. Contacts HCC 3 and HDD 2 prepare a circuit for the lighting of the position lamp.

Assuming that a message came to hand for transmission over the above circuit, the operator at the distribution position, observing from the glowing of the circuit busy lamp that the circuit was already engaged, would operate the circuit key associated with the lamp. The operation of this key causes relays A and D to operate to earth via the uniselector wiper W 1. Contact A 1 provides a holding circuit for these two relays. Contact D 2 removes a short-circuit from across the 3,000-ohm resistance in the sleeve circuit of the engaged line. This reduces the current flowing in the sleeve circuit and results in relay HDD releasing. Contact HDD 2 extends battery via relay HA, metal rectifier, "close down" and "reserve" keys and wiper W 3 of the uniselector to earth, thus causing relay HA to operate. Contact HA 3 lights the required position lamp on the distribution panel and also operates relay L. Contact L 1 operates relay F, which, at F 1, lights the circuit hold lamp and operates relay G. Contact G 1 locks the G relay, thus maintaining the circuit hold lamp alight.

The operator at the distribution panel notes the required position number and marks it on the message. The message is then placed on a conveyor serving the suite containing this position. When it is received at the drop point serving this suite a circulation officer delivers the message by hand to the position concerned, and at the same time operates the reset key on the position keyboard. This breaks the locking circuit of relay G which releases and thereby extinguishes the circuit hold lamp. The position lamp darkens immediately the operator at the distribution panel releases the circuit key, but the circuit busy lamp remains glowing as long as the circuit is engaged.

The circuit operation, when the incoming side of a direct telephone-telegram circuit is concerned, is similar to the above.

During busy periods it is necessary to staff both distribution positions, and the operators staffing each position must have access to every direct telephone-telegram circuit. The whole of the circuits must therefore appear on each distribution panel. It was not possible to have a simple multiple of the lamps and keys, because under such conditions a key operated on either panel would light the position lamp on both panels. This would cause serious

inconvenience when both operators were pressing different circuit keys simultaneously as two position lamps would glow on each panel, and neither operator would be able to determine which of these lamps was associated with her particular circuit key.

The difficulty was overcome by arranging for the whole of the 96 telephone-telegram positions to be connected to each panel alternately. A uniselector stepping under the control of earth pulses supplied by a special cam on the ringing machine is used to effect the switching of the positions, which are connected to each panel in turn for approximately four seconds. Under this scheme, if a key is operated on one panel when the positions are connected to the other it is only necessary to hold the key for a very short period, at the end of which time the positions will be connected to the panel concerned. This period of waiting, when it occurs under actual working conditions, is barely perceptible. A key is provided so that the uniselector may be switched in or out of circuit as required. Another key is provided to bring in a spare uniselector should a fault develop on the working switch.

Distribution Speaker Circuit. When a message is received at the distribution position for a circuit which does not show engaged, the message is placed, unmarked, on a conveyor. When the message arrives at the drop point it is circulated to a disengaged operator, who disposes of it in the normal way. During busy periods it often transpires that, during the time taken for a message to circulate from the distribution panel to an operator in the above circumstances, the circuit becomes engaged. Therefore the operator desiring to dispose of the message encounters engaged click on the circuit jack. In order to minimise delay arising from this cause a speaker circuit has been provided between the distribution position and the telephone-telegram positions. The circuit appears in the outgoing multiple on every telephone-telegram suite, while at the distribution position it is terminated on a lamp. A loud-speaker associated with a 2-valve amplifier is provided for receiving incoming speech from the operators. The transmitter at the distribution position is fixed to a flexible arm mounted vertically on the desk. This arrangement releases the distribution operators of the necessity of wearing a headgear receiver and breastplate transmitter, thus allowing them full freedom of movement for the circulation of messages. The loud speaker and transmitter can be seen on the right of the distribution position in Fig. 4.

When an operator has a message for a direct telephone-telegram circuit which tests engaged, she plugs into the speaker circuit jack. This causes the calling lamp to glow at the distribution position and draws attention to the fact that an enquiry is about to be made. The operator then quotes the code of the engaged circuit, and, on being informed of the number of the position engaging this particular circuit,

marks the message accordingly and arranges for it to be delivered to the required position.

The action of the distribution operator when ascertaining at which position the circuit is engaged results in the glowing of the circuit hold lamp at the engaging position. Thus the operator at this position is warned that another message is being circulated to her for transmission over the circuit she is engaging.

Telephone-Telegram Deconcentration Positions.

Although the 96 telephone-telegram positions are sufficient to handle the normal traffic there are certain days in the year, e.g., Christmas, Easter, race days

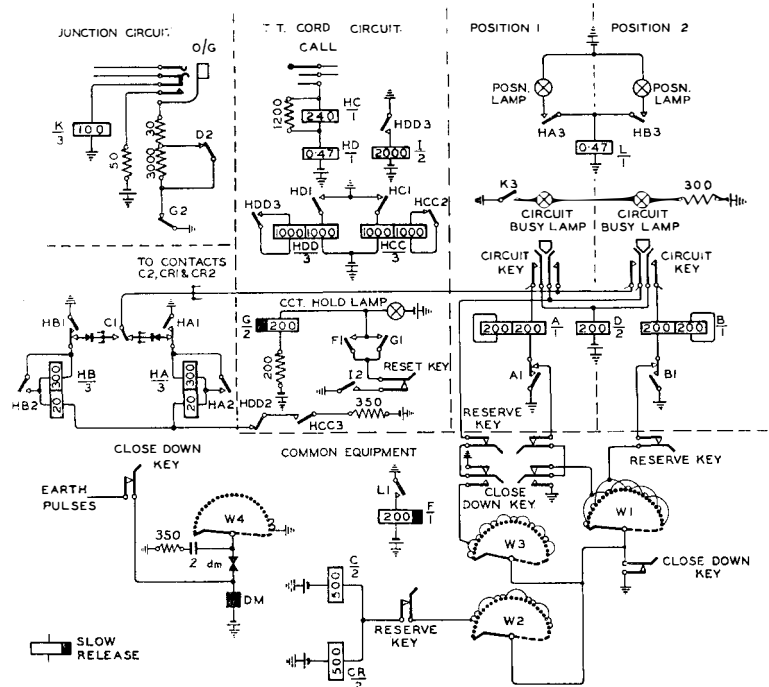

FIG. 5.—DISTRIBUTION POSITION CIRCUIT.

and Saturday mornings, when they are unable to deal efficiently with the increase in traffic. To ease the load on the normal positions during these exceptionally busy periods the deconcentration positions are staffed. Fig. 6 is a photograph of the deconcentration positions. The deconcentration switchboard can be seen on the right of the photograph. A certain number of selected direct telephone-telegram circuits and incoming exchange telephone-telegram circuits are wired permanently to jacks and lamps on the switchboard. These jacks and lamps are in parallel with the normal jacks and lamps, and a key is provided on each circuit at the switchboard so that the lamp may be cut out when not required. The deconcentration positions are terminated on plugs at the deconcentration switchboard.

In order to connect any one of the selected circuits to a deconcentration position it is only necessary to insert the plug of that position into the required circuit jack on the deconcentration switchboard. A listening circuit is provided so that the officer

extending the circuits may, by listening on the line, ensure that a call is not in progress before the circuit is extended. It is possible that a circuit may be left through to a deconcentration position when the latter is unstaffed. In this case the line lamp at the



FIG. 6.—DECONCENTRATION POSITIONS.

position would glow on receipt of a call but, being on the keyboard, would probably escape notice for some considerable time. As a guard against this a lamp has been provided on each circuit in the switchboard jack field and is switched in whenever the circuit is extended. Should the circuit be left extended after the operator has vacated the position any further calls will light this lamp, which will readily be seen by staff who are always in the vicinity of the switchboard. A telephone circuit is provided on the switchboard so that the controlling office may give assistance when required.

When a direct telephone-telegram circuit is extended to a deconcentration position its appropriate circuit keys on the distribution panels are designated with the number of the particular position to which the circuit is connected, thus indicating to which point messages for this particular circuit should be circulated.

Phonogram Cord Circuit.

The phonogram cord circuit arrangement is shown in Fig. 7. The whole of the cord circuit apparatus, with the exception of the keys, plugs and lamps, is contained in an auxiliary apparatus unit similar to the telephone-telegram cord circuit unit, and is known as a "Unit Auxiliary Apparatus TL 2041." The answering side of the circuit is simply the standard C.B. arrangement. The calling side is arranged to discriminate between junctions to automatic exchanges and junctions to manual exchanges. Briefly, the circuit operation is as follows:—

When the calling plug is inserted into a jack outgoing to an automatic exchange it meets a high resistance earth on the sleeve of the jack. This results in the cord circuit relays HC and HCC operating, but not HD or HDD. Contact HCC 3 disconnects the engaged test circuit while HCC 2 lights the calling supervisory lamp. Loop dialling conditions now exist on the calling cord, and the operator completes the call in the normal manner. When the called party answers the reversal of the battery and earth at the automatic exchange causes the polarised relay DC to operate. Contact DC 1 extinguishes the calling supervisory lamp, thus giving standard supervisory conditions. If the calling plug is inserted into a jack outgoing to a manual exchange it meets a low resistance earth on the sleeve of the jack. This results in relays HC, HCC, HD and HDD operating. The first two relays perform much the same function as on a call to an automatic exchange, while contacts HDD 1 and 2 substitute CB conditions for loop dialling conditions on the calling cord.

Position Lamps and Traffic Indicators.

Two lamps, one red and one green, contained in one fitting, are provided on top of the suites at each operator's position. When the position is staffed, but not actually engaged on a circuit, the green lamp glows. When the operator plugs into an outgoing

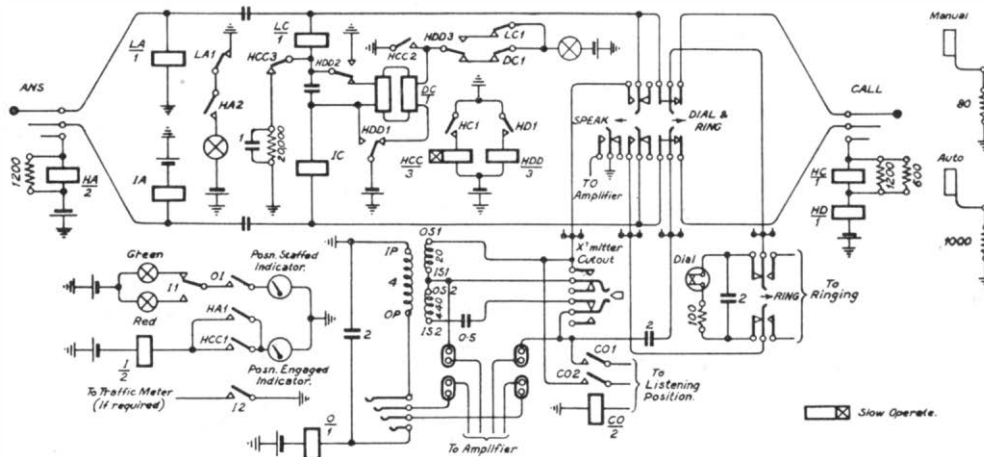

FIG. 7.—PHONOGRAM OPERATOR'S CORD AND TELEPHONE CIRCUIT.

or incoming jack, the green lamp darkens and the red lamp glows. These lamps facilitate the distribution, to operators, of messages to be forwarded, the officer distributing the message being able to see at a glance which positions are disengaged. Referring to the cord circuit diagram in Fig. 7 it will be seen that it is the condition of relay I which determines whether the red or green lamp glows.

Traffic indicators consisting of milliamperemeters fitted with suitable shunts, and calibrated to indicate numbers of positions, are mounted on the supervisors' desks. One "Positions Staffed" and one "Positions Engaged" indicator are common to a certain number of phonogram and telephone-telegram positions. The indicators serving the phonogram suites can be seen in position on a supervisor's desk, on the right in Fig. 1.

By comparing the readings of the two indicators for each group of positions the supervisors are able to see at a glance whether the staffing arrangements require attention. The circuit arrangement, which is quite simple, is shown in Fig. 7.

Free Line Signalling Facilities.

To provide an outlet to exchanges which have no direct junctions to phonograms, 7-digit dialling conditions are provided on a large group of outgoing junctions to National exchange. In order to save time in testing these junctions for engaged click, free line signalling facilities have been provided. The current for the lamps is drawn from the A.C. mains supply, and in order to prevent mains hum interfering with adjacent speaking circuits great care had to be exercised with the cabling and wiring.

Listening Facilities.

Facilities are provided for listening-in to any operator on the phonogram or telephone-telegram-suites by wiring out the secondary winding of the induction coil at each position via the contacts of a relay to jacks accommodated on a listening-in panel.

As the listening-in position is situated some considerable distance away from the suites of positions it was necessary to take precautions against cross-talk between operating positions arising from the long length of cable carrying the listening-in leads. It is for this reason that a relay has been provided in the circuit at each position. The listening-in taps are thus disconnected from the operator's circuit until listening-in is actually in progress on the circuit. A transformer has been provided in the common listening-in circuit to ensure that the action of listening-in does not introduce any appreciable loss on the circuit under observation.

Any position may be extended from the listening-in panel to the supervisors' desks by means of double-ended cords and extension jacks. The arrangements are such that even when a position is extended in the above manner the listening-in taps are not connected to the operator's circuit unless the supervisor is actually listening on the circuit.

Observation Facilities.

In the observation circuits, clip connections on the I.D.F. have been avoided. The points on the line

circuits which have to be connected for observation purposes are cabled out to "Jacks, Test No. 17." The observation tapping circuits are also cabled out to "Jacks, Test No. 17." The jacks are mounted on the observation apparatus rack, where connections between the line circuit apparatus and the observation equipment are made by means of "Clips, Test, No. 1/18B." The line connections on the M.D.F. are made in the usual manner by means of the standard test clip.

There are two observation panels equipped to accommodate thirty line circuits. The line jack and line lamp fields of the panels are connected in multiple. Immediately above each strip of line jacks is a designation strip to carry labels bearing the appropriate circuit code for each jack. The labels consist of "Pegs No. 15, White," suitably engraved, and are changed by the traffic staff to agree with the circuits connected to the panels at any time. The red and green lamps indicating exchange and phonograph operator conditions respectively are fitted at the bottom of the panel.

When a line is connected up for observation, but is not actually being observed, the circuit arrangements are such that the tapping equipment is short circuited. This ensures that there is no loss on the circuit unless it is actually under observation.

Earthing Scheme.

Owing to the distance between the suites and the line relay equipment it was found necessary to devise a special earth wiring scheme for the whole installation, the purpose being to obviate false engaged conditions arising on the sleeves of the outgoing jacks at times when the load was heavy. In general, the arrangement consists of earthing the sleeve circuits of the outgoing junctions near the switchboards and not, as is usual, on the apparatus racks. In this way the P.D. between the tip of a plug and the sleeve of the jack of a disengaged junction is kept to a minimum.

Photogram Concentration Facilities.

The phonogram section gives a 24-hour service, and must necessarily be staffed day and night. Arrangements have therefore been made to concentrate on two suites (C and D) :

- (1) all the incoming exchange lines within the phonogram section ;
- (2) all the incoming exchange lines from the foreign section (on the second floor) ; and
- (3) all the incoming exchange lines from the telephone-telegram section.

Ancillary Switching Cabinets.

In order to make full use of the standard phonogram and telephone-telegram ancillary scheme, all the keys controlling the ancillaries are concentrated at one point in the phonogram and telephone-telegram sections. The keys are mounted in special cabinets and are adequately labelled. The operation of the keys cuts in or out the different ancillaries as required. The keys are also used for closing down or opening up suites as the traffic load varies.

Problems Involved in the Preparation of a European Trunk Switching Plan

A. C. TIMMIS, B.Sc., A.M.I.E.E.

A "Commission" of the C.C.I.F. has been established to prepare a trunk switching plan for Europe. This article gives information concerning the problems involved and the investigations being carried out.

Introduction.

THE rapid growth of the international telephone service, which is now generally admitted to have attained a high degree of efficiency, is due to the successful co-ordination of effort brought about by the C.C.I.F. A network of cables and repeater stations serves the greater part of western Europe, and a satisfactory telephone service is assured almost from any exchange to any other. Methods of operating and maintaining the international lines and the apportionment of the revenue have been settled. The next step is technical co-ordination of the national and international systems in such a way that the line plant may be designed and operated most economically. At the present time the general standard of transmission is by no means unsatisfactory, but as telephone instruments improve and long distance telephony becomes more widespread a still higher standard will be demanded.

In 1934 the C.C.I.F. appointed a technical sub-committee to study the problem and prepare the framework of a "Plan of Interconnection," or trunk switching plan, for Europe. The American Telephone and Telegraph Co., which operates a trunk system of continental dimensions, covering the whole of the U.S.A., has already a "Toll Switching Plan" which among other things enables on-demand service to be given all over the system. Engineers of the American Telephone and Telegraph Co. have given the sub-committee information regarding their plan and its application in America. Research work is now proceeding here and on the Continent.

During the assemblée plénière of the C.C.I.F. at Copenhagen in June, 1936, the sub-committee was elevated to the rank of a "mixed commission" with technical and traffic members. The British Post Office is represented by one engineer from the Research and one from the Lines Branch, and one traffic member. A questionnaire has been issued by the commission with the object of finding out the present conditions in all European countries as regards the national lines which are used for international service.

Technical Problems.

Throughout this article the nomenclature adopted by the C.C.I.F. is used as far as possible. The "equivalent" of a line or speech channel is the apparent attenuation measured with an appropriate power at any speech frequency, usually 800 c.p.s. It is sometimes called "overall equivalent" and is usually a positive quantity, being the total losses in the circuit less the total gains. The American term "net loss" expresses this idea, whereas the term "equivalent" comes from "standard cable equivalent," now obsolete.

Although a modern 4-wire circuit may be extended almost without limit, certain factors which are negligible on the majority of inland trunks become increasingly important when we have to deal with distances of the order of 1,000 miles. Generally, but not invariably, these factors can be dealt with by increasing the equivalent of the circuits, but the overall equivalent of the whole chain of connections is limited as regards its maximum value by the agreed standard of transmission. Hence the equivalent of the national circuits used to extend the international lines must be reduced. Though shorter than the international lines, they are more numerous and in some cases may be necessarily unrepeated lines, the equivalent of which can only be reduced by using heavier conductors. Every decibel added to the equivalent of the international link means, sooner or later, heavy increase in the cost of the national lines. It is therefore essential to determine the best overall equivalents at which international lines can be worked, not only under present conditions but also after those improvements which may be indicated by a technical and economic study have been made.

The most important of the C.C.I.F. rules (avis) which govern the design of national and international lines at present may be summarised as follows:

(1) The "reference equivalent" of an international call (from subscriber to subscriber) should not exceed 40 db. in 10 per cent. of the connections and 34 db. in 90 per cent. of the connections. With the telephone instruments and subscribers' lines most generally in use this means that the total equivalent of the lines between terminal exchanges, including exchange losses, must not exceed 28 db. at 800 c.p.s. in 10 per cent. and 22 db. in 90 per cent. of the connections. An international line (which may be made up of 1, 2 or even 3, international trunks) should have an equivalent of 2.6 db. when connected to national trunks at each end. This is derived as follows:

An international trunk should be practically zero, say, 0.1 ± 0.1 neper to allow for variations. The equivalent of three such trunks joined together (the most severe condition which need be considered) would be 0.3 ± 0.2 neper or 2.6 ± 1.7 db.

(2) An international line should transmit frequencies up to 2,600 c.p.s., the equivalent at this frequency being not more than 9 db. higher than at 800 c.p.s.

(3) Limits of noise, crosstalk and variation of repeater gain are stipulated for international but not for national lines.

(4) Certain limits (by no means severe) of stability and echo effect are recommended for national lines.

A complete trunk switching plan must obviously include rules covering the various characteristics of both national and international lines when used in conjunction, but there are certain matters, such as echo effects with and without echo suppressors, which have not yet been fully investigated. These will be discussed in the following section, under the appropriate headings.

FACTORS WHICH LIMIT THE WORKING EQUIVALENT OF CIRCUITS.

These limitations may be arranged more or less in order of importance as follows :

- (1) Variations of repeater gain and line attenuation.
- (2) Stability.
- (3) Echo effects.
- (4) Crosstalk and line noise.
- (5) Propagation time.

Room noise has been omitted from the list because it may be assumed that a subscriber who is making an expensive long distance call will take care to have the room reasonably quiet. Moreover, room noise is outside the control of the designer.

(1) *Variations of Gain.*

Variations of gain are due mainly to variations of filament or anode battery voltage ; but there are slower changes such as those due to ageing of valves. When a valve is nearing the end of its useful life the gain varies considerably with change of filament current, so that the effect of battery variations is aggravated. The attenuation of underground cable pairs varies with temperature but in a slow and regular manner, so that periodical adjustments of the repeaters suffice to correct the equivalent of the circuit. With open wires or aerial cables, however, the variations are rapid and automatic alarms or compensating devices are required. At present most repeater stations of Europe depend on batteries for filament current. The anode current is often supplied through rectifiers from A.C. mains. In general the voltage regulation is such that overall equivalents do not vary enough to interfere with the service, but the variation should be reduced to enable the longer international circuits to be worked at a lower equivalent. To this end the C.C.I.F. has just recommended that repeater gains be maintained within ± 0.03 neper (± 0.02 for circuits with more than 12 repeaters) by the use of automatic regulators on filament and anode supplies. Assuming random addition, a change of ± 0.02 neper corresponds to $\pm 0.02 \times \sqrt{25} = \pm 0.1$ neper for a circuit containing 25 repeaters. When this source of variation has been practically eliminated there will remain the slow changes mentioned above, but with a reasonable period between adjustments a range of less than ± 0.2 neper (say ± 2 db.) may be assumed on any international circuit.

Variations have two distinct effects :

(1) Long trunks have generally to be adjusted to equivalents several decibels higher than the minimum possible, lest the actual equivalent be reduced due to these variations to a point where the circuit

becomes unstable. Before this happens echo or other effects may become intolerable, but instability is the most serious, as it makes the circuit definitely unworkable. Hence, for through connections, pad switching, cord repeaters or similar devices must be used in order to keep the overall equivalent within the prescribed limits.

(2) Satisfactory transmission cannot be assured over the whole system if the main links are liable to have a loss several decibels more than their normal values.

The second effect is by far the more serious, for it cannot be overcome by cord circuit repeaters or by any means other than upgrading the shorter lines. As the shorter lines are much more numerous than the main trunks and are generally unrepeated, their attenuation can only be reduced by using heavier conductors. It is evident that every decibel reduction in the equivalent of these lines will cost a very large sum of money, whereas the cost of repeated lines does not depend so directly on their equivalents. Within a certain range, for instance, it may only be a matter of adjusting repeater gains.

Pad switching offers a simple way to overcome the first effect, but if it is used variations do not call attention to themselves by producing instability and the second effect may easily be overlooked. The general standard of transmission must inevitably suffer in consequence. This is perhaps the strongest argument against the general use of pad switching.

The method will be referred to again under "stability."

In addition to these unavoidable variations, erratic changes occur due to varying contact resistances in jacks, potentiometers, etc. Such variations can be prevented almost entirely by the use of U links with firm contacts, as in the latest English and German practice, but there are many thousands of less satisfactory contacts on international lines which must remain for some years.

It will be quite evident that the variation factor overrides all the others. Hence it is put first in order of importance.

(2) *Stability.*

A 4-wire circuit is stable, with both ends disconnected, when the equivalent measured in the usual way is between zero and 2.8 db., according to the terminal transformers. But a 2-wire circuit is only stable, under the same conditions, when its equivalent is from 1 to 12 db. or more, depending on the number of repeaters and the accuracy of the balances. This is the main reason why nearly all international trunks are now 4-wire circuits. When echo-suppressors are fitted, as they are in the longer trunks, the most severe condition as regards stability occurs when the local lines connected to each end have an impedance so different from the 600-ohm compromise balance that together they provide a "stability" of about 5 db.; i.e., the equivalent in each direction may be reduced 5 db. before actual singing occurs.

In a very few cases somewhat worse conditions may occur, but the chance of two extensions with

worse impedances being connected to the same trunk is so remote as to be negligible.

It is found by experience that a 2-wire or 4-wire circuit will be free from noticeable distortion due to incipient oscillation or "near singing" (to use the American term) if its equivalent is 4 db. above the value at which it is just stable. Hence there is a margin of 1 db. in the most severe case that need be considered. When an echo-suppressor is fitted, as is usual when the equivalent is small, the difference of 4 db. mentioned above is not required. The suppressor prevents circulating currents which give rise to "near singing," and, further, it limits the volume of any singing that may arise when the circuit is out of use, with both ends disconnected.

There is some difference of opinion as to the precise value of stability which should be adopted, as the following table shows.

Authority.	Stability.
British Post Office	- 2.5 db., ends disconnected, with echo suppressor. 2 db., ends disconnected, without echo suppressor.
A.T. & T. Co.	5 db. in talking condition (for 2-wire and 4-wire circuits, corresponding to zero with ends disconnected). ¹
C.C.I.F.	2 db., ends disconnected.

One of the duties of the mixed commission will be to decide on stability values for different types of national and international circuits, and also to recommend methods of calculating the minimum equivalent from the point of view of stability. The present practice is to work international (4-wire) circuits at 4 to 8 db. equivalent for terminal traffic. As would be expected with this ample margin for variations, instability very rarely occurs. When, however, the connection extends to national lines, which may be 2-wire, repeatered or unrepeatered circuits, with an equivalent of 10 db. or more, a cord circuit repeater is often used and stability is reduced. In effect one more 2-wire repeater is added. It is the practice in America to use attenuators (pads) on the majority of trunks, these pads being cut out to reduce the equivalent for through traffic. In Great Britain both cord circuit repeaters and pads are dispensed with by working the main trunks at zero equivalent, and connecting them together at the exchanges in the ordinary way.

This very simple method lends itself particularly well to "on demand" working and does not give rise to trouble provided the circuit equivalents do not fall appreciably below zero. To take an extreme case, by way of example:—A chain of three zero circuits would be just stable (ends disconnected) at about 3 db. With the most severe terminal conditions there would be a stability margin of $5-3 = 2$ db. The echo-suppressors would remove any risk of "near singing" distortion, but if two of the trunks chanced to be

1 db. low in equivalent in both directions and at the same time both terminal impedances were at their worst—a very remote chance—the connection would be unstable.

It does not follow, however, that the whole European trunk system could safely be worked on the basis of zero-loss 4-wire trunks. At the present time it is generally considered unsafe, and in some countries it is the practice to eliminate the mismatch of impedance at the junction of 4-wire trunks by means of the "link" connection or by cutting out the terminations. The reflection at the switching point has only a slight effect on stability, especially if terminal repeaters are fitted. There is another reason for its elimination which will be dealt with under (3).

To summarise the position as regards stability: it seems probable that when the C.C.I.F. recommendation as regards variation of repeater gain has been fully applied, both to national and international lines, and contact resistances have been eliminated, instability will be of very rare occurrence and from this standpoint it will be practicable to work the international trunks at zero equivalent, although at the same time a number of national circuits may also have zero equivalent. Provided that maintenance tests are made at short intervals the slow changes of amplification mentioned above should tend to increase rather than decrease the equivalent. This seems to be so at present, judging by some typical measurements on six long international circuits. The maximum *increase* of equivalent (average of the two directions) was $2\frac{1}{2}$ times the maximum *decrease* from the normal value, so that the circuits tended to become more stable. The measurements were made at the end of June, while temperature was rising, and possibly increasing resistance may have accounted for most of the observed change. Measurements taken on the same six lines during November gave no clear evidence of change due to falling temperature. It must not be overlooked that a number of international circuits will be provided by means of aerial line carrier systems on which the regulation may not be so close as on underground cable circuits.

(3) Echo Effects.

The phenomenon of electrical echo was first noticed on long 4-wire circuits adjusted to a low equivalent. Practically all the echo-suppressors now in use are fitted at intermediate repeaters on circuits of this type. The exceptions are suppressors incorporated in the terminal equipment of radio links, and the metal rectifier suppressors designed and adopted by the B.P.O. which are used at a terminal of a 4-wire circuit or in conjunction with a 2-wire repeater. On a simple 4-wire circuit the echo-suppressor is most conveniently placed somewhere near the middle and need not be very quick-acting. It has only to operate before the echo current returns from the far end of the line. When one or more carrier channels are added to a 4-wire line, however, intermediate suppressors require the audio and carrier channels to be separated by means of filters. It is preferable to use terminal suppressors for this

¹The A.T. & T. Co. allow a stability of -1 db. (ends disconnected) on circuits having one repeater only and no echo suppressor.

reason and because they can readily be cut out if the trunk is required for a voice-frequency telegraph system, or picture transmission. But terminal suppressors involve two difficulties:—

(1) Very quick operation is required to suppress the echo caused by reflection at the near end, since the propagation time between the "return" and "go" repeaters is practically zero. See Fig 1.

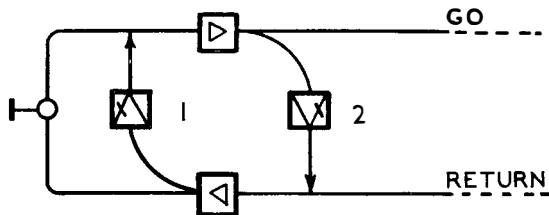

FIG. 1.—COMPLETE (DOUBLE) TERMINAL SUPPRESSOR.

(2) The first few waves of the echo current, which must get through before suppression, may operate suppressor 2, and cut off the incoming speech.

The differential connection in the metal rectifier suppressor and its very short operating time overcome these troubles, enabling it to be used at either end of a 4-wire circuit or at any repeater in a 2-wire circuit. In Germany the difficulty was overcome by using two single-way echo-suppressors, one at each end of the line. The arrangement is shown in Fig. 2.

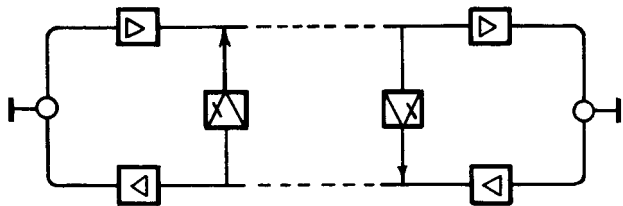

FIG. 2.—SINGLE TERMINAL SUPPRESSORS.

The suppressors must be very quick-acting; otherwise the first part of the echo will get through to such an extent as to be noticeable. Suppressors of this type have disadvantages as compared with a complete (both way) terminal suppressor. Obviously they must be somewhat more costly; also, if two circuits equipped with these suppressors are connected together, and if to avoid "lock-out" (the danger of which has not been established) the suppressors at the junction are cut out, the end suppressors are liable to false operation by currents reflected from the junction. This is avoided by using the "link" connection or cutting out the terminations. Both these expedients are complicated and it is now generally agreed that they are not justified. The whole question, however, is one of those being studied by the mixed commission.,

Returning to the intermediate suppressors, which are mostly of the valve type in Europe and the relay type in America; it has generally been assumed that the suppressor wipes out echo under all practical conditions. Actually, to prevent false operation by noise, the sensitivity of the suppressor is limited and a weak talker may fail to operate it. The echo is, of course, weak, but it may give the talker an

impression of something irritating which he cannot define, associated with sibilant words like "sixty-six." By a series of judgment tests, first made in the U.S.A. and repeated by the British, French and German administrations, an approximate relation between echo time and the minimum equivalent at which the echo is just tolerable has been established, with and without a suppressor.

These tests were made by experts, using selected words and keeping the speech volume within a limited range. A subscriber would only notice the effect very rarely, for it is necessary that his transmission should be weak and reception good if the echo is to be audible. Therefore an equivalent substantially lower, giving a greater volume of echo when it occurs, could be tolerated in actual service. The problem is now being studied in all its aspects by members of the mixed commission, with the object of fixing a design curve which will show the relation between circuit equivalent and echo time to be used in calculations.

Where a long 2-wire circuit is connected to each end of a 4-wire international line the total echo effect may be computed, using various assumptions and the judgment data mentioned above. The method is that used by the American Telephone and Telegraph Co. and its application to European conditions is being studied. One of the most interesting questions is how the several intermediate echoes in a 2-wire circuit affect the talker as compared with a single echo. It is a psychological problem and therefore incapable of exact solution, but some tests made recently in London indicate that the law of random addition gives a fair approximation.

The echo effect cannot be ignored because it seldom occurs. It is most likely to be noticed on very long and expensive calls where regular users would be quick to complain.

(4) Crosstalk and Line Noise.

Intelligible crosstalk enables conversation to be partially overheard during silent intervals and cannot be tolerated, on the score of secrecy, if the crosstalk attenuation is less than about 55 db. This figure has been found a reasonable limit in practice, but the C.C.I.F. has now decided to aim at 65 db. for international lines having an equivalent of 7 db. The American Telephone and Telegraph Company adopts a limit of 60 db. for 99 per cent. of calls, based on probability.

Crosstalk can generally be improved by reducing the equivalent of a circuit. If we imagine the disturbed circuit to be degraded, say, 5 db., by reducing the gain of the receiving amplifier, evidently the crosstalk will be 5 db. weaker. Similarly, if an international trunk is upgraded from 7 db. to zero, the crosstalk attenuation becomes 58 db. instead of 65 db. This applies both to near-end and distant-end crosstalk. The crosstalk attenuation to be expected depends, according to the random addition law, on the distance over which the disturbed and disturbing circuits are adjacent. For example, a 400-mile circuit would have 6 db. worse crosstalk than a 100-mile circuit in the same cable, and might have to be worked at a higher equivalent in consequence.

Combined crosstalk from a number of circuits (babble) is unintelligible and ranks with power induction, etc., as "line noise." Babble is not disturbing as a background even if several decibels louder than the allowable volume of intelligible crosstalk, but the disturbing effect depends on the ratio between the speech and the babble, usually called the signal/noise ratio. If, therefore, we degrade the circuit to reduce the noise this ratio is unchanged. Evidently noise is not a factor tending to increase the minimum circuit equivalent. It is in fact an impairment, like limitation of frequency band, and must be dealt with by fixing maximum values for different types of lines. The problem is complicated by the infinite variety of types of noise, and the final judgment depends on economic considerations.

(5) *Propagation Time.*

The speed of propagation over a loaded line depends on frequency, being less at low and high speech frequencies than at 800 or 1,000 c.p.s. For ordinary telephony the result is that frequencies of 2,000 to 2,500 c.p.s. arrive at the end of a long line some milliseconds after the middle frequencies of speech and are heard as "transients." The effect on intelligibility is slight, but the chirping sound of the transient is disturbing and limits a fairly heavy loading (such as 120 mH. at 2,000 yds.) to about 800 miles. The most usual loading for long continental cables is 44 mH. at 2,000 yds., for which the limit is 4,000 miles. It would be quite possible to reduce the

transient by degrading the circuit, but the question hardly ever arises in practice.

It is found that if the time exceeds $\frac{1}{4}$ sec. each way at middle frequencies, there is an extra delay between question and answer which may cause repetition and misunderstanding. The available 250 milliseconds has been divided into 150 milliseconds for the international line and 50 milliseconds each for the national lines to which it may be extended, with a recommendation that all long international lines should have a velocity of at least 20,000 miles per second, corresponding to 44 mH. loading. A transatlantic telephone cable is a possibility which must be provided for in the future, and therefore the full allowance of 250 milliseconds should not be used up on land lines. With this in view and to ensure that a call from, say, Hollywood to Moscow could be made entirely through cable, a lighter loading than 44 mH. (or no loading at all) is now envisaged. On such lines multi-channel carrier working is possible and the transient effect is quite negligible.

On heavily loaded cables, where transient effects might be serious, other limiting factors generally control the working equivalent of the circuits.

Conclusion.

Of the several problems which have been briefly outlined in this article the question of echo effects is perhaps the most interesting. Various experiments are now being made here and in other countries and the whole problem of echo effects will form the subject of a separate article.

Automatic Door Operating Gear

Complaints arise due to draughts in sorting offices as a result of the long periods in which the sorting office doors are kept open to facilitate the frequent passage of trucks of mail into and from the sorting office. The swing doors that are usually provided are generally operated by pushing the trucks against the doors, with the result that both the doors and trucks become damaged.

An experiment has been carried out at Redhill Station sorting office, in which the doors are automatically operated by the interception of light rays on the approach of a vehicle. To ensure that there shall be absolutely no draught, two sets of doors are used, the space between acting as an airlock. The automatic gear is arranged so that one of doors closes before the second opens.

The operation is performed by utilising the well-known characteristics of selenium cells, whose resistance increases when subjected to a reduced intensity of illumination. Four cells, two for each door, are sunk in the floor under glass pavement lights, about 6 ins. square, while a 6-volt 6-watt lamp is fixed to the ceiling directly over each selenium cell on to which the light is focused. When the beam is intercepted, the resistance of the cell is increased

and this is utilised to vary the grid potential of amplifying valves, the anode current of which operates relays controlling the door operating gear. A time lag is introduced by means of a potentiometer which varies the negative potential applied to the grid of the amplifying valve and so varies the time taken for the negative charge on the grid to leak away through a 2 megohm resistance before the anode potential can rise sufficiently to operate the relays. The time between the interception of the beam and the door opening in the fully operated position can be easily adjusted between $2\frac{1}{2}$ to 10 seconds. The time the door remains in the fully open position is approximately 5 seconds.

The valve amplifiers, condensers, potentiometer, etc., are contained in a cast-iron case fixed near the door. The operating gear is fixed over the door and consists of a $\frac{1}{4}$ h.p. 220 volt single phase A.C. motor, the speed reduction of which is obtained by means of spur gearing.

The doors are opened by cams and bell crank levers, and are held in the open position by an electro-magnetic brake on the motor shaft. Hydraulic buffers are fitted to prevent bounce of the doors during opening. The doors are closed by springs when the brake is released.

Modern Developments in Television

S. T. STEVENS

Part I. Transmission Systems

In the first part of this article, which will be continued in the July issue of the Journal, the author details the requirements of the new television service and describes Transmission Systems now in use which employ mechanical or electronic scanning.

Introduction.

THE recent opening of the London Television Station has inaugurated in this country a new system of telecommunication and will have excited interest in this novel subject. In the following article an attempt will be made to outline the principles of operation of some of the devices used in this new art.

It will be readily appreciated that the eye itself forms part of a very perfect television system, a system so perfect that the highest endeavour of human art will never be able to compare with it in efficiency. Scenes focused by the lens of the eye are projected on the retina whence the light produces sensations which are communicated to the brain. The way in which light effects stimulate the optic nerves is not clearly understood, but it seems probable that chemical effects are called into play.

The simplest television system which can be conceived is one which at the pick-up point simulates the eye and consists of a lens system which projects the scene to be televised on an artificial retina composed of multitudes of photo-electric cells (Fig. 1). Each

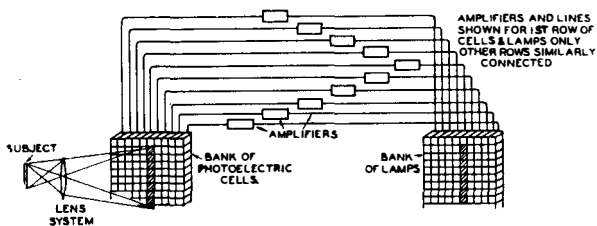

FIG. 1.—PRINCIPLE OF A SIMPLE TELEVISION SYSTEM.

cell would be connected to the receiving point by a separate circuit containing suitable amplifiers. At the receiving point each circuit would be connected to a separate lamp on a screen similar to the artificial retina such that each lamp occupied a position on the screen similar to the position of the photo-electric cell to which it was connected. The system would be adjusted so that each lamp would be illuminated in proportion to the light falling on the photo-electric cell to which it was connected. This system may be described as the basic and ideal system of television.

In order that such a system should be capable of presenting a few square inches of picture with a definition equivalent to the average half-tone reproduction as used for the reproduction of photographs in newspapers and magazines, it would be necessary to provide something of the order of 100,000 units each consisting of photo-cell, lines, amplifier and lamp. Such a system would, of course, be prohibitively costly, and inventors have tried to devise methods which would be economically possible. The obvious development would be to retain the photo-cells and the lamps but to use one connecting line and amplifier and to switch the line, at each end simultaneously, from unit to unit very rapidly. This modification

would normally only allow illumination to appear from each lamp for the brief instant when it was connected to the line. Provided the repetition of illumination occurs sufficiently rapidly the eye will not appreciate that each spot of light has not been continuously illuminated.

The rate of repetition necessary to avoid flicker depends upon the illuminator. For poorly illuminated cinematograph or television screens repetition rates of 25 per second are not too obvious. For brighter illumination a rate of 50 pictures per second is tolerable. With more brilliant lighting, such as is used for reading purposes, 50 pictures per second is too slow, as everyone who has tried to work or read in light from a 25 c.p.s. supply (50 pulses per second) will have been painfully aware. This suggests that if television equipments improve and present us with really brilliant pictures it may be necessary to increase the picture speed to 75 or 100 per second.

Any system of mechanical switches to connect each light cell with its appropriate lamp would be difficult and expensive to construct and would also be liable to give trouble in use owing to the high switching speed necessary. Fortunately, science has provided a device admirably adapted to serve as a reliable switch, viz., the cathode ray tube in which a stream of particles of negative electricity serves as the moving switch arm. In the pick-up device this stream can be directed to pick up the energy from each photo cell or group of photo cells in turn and be caused to impinge on a fluorescent screen, the particles of which take the place of lamps and are stimulated into illumination by the impact of the electron stream.

Other methods are available: for instance, a beam of light controlled by rotating mirrors to replace the moving switch arm. In this method a single photo-electric cell can be used at the pick-up point and a single lamp at the receiving point. The illumination of the various points on the pick-up screen being focused on the screen in turn, while at the receiving end the light from the lamp is projected on the various points of the receiving screen in their proper order. Systems using moving light beams are generally referred to as mechanical systems. The traversing of the pick-up screen by a beam of light or electron stream is termed "scanning," and the simplest method of scanning is to traverse the screen by a number of parallel and closely adjacent tracks either horizontally or vertically. Sometimes the scanning is effected by traversing the screen by a series of lines not closely adjacent but with the width of a track between them. The spaces between lines unscanned in the first operation are then scanned in a subsequent operation. The first method of scanning is called sequential scanning, while the second type of scanning is called interlaced scanning.

Other methods of scanning have been proposed, but they usually involve additional difficulties in an

already complex problem so that all working systems at present use either sequential or interlaced scanning as mentioned above. It would be a rash person, however, who ventured to state that other methods of scanning would never be adopted or even that scanning itself might not eventually be dispensed with in favour of some nearer approach to an ideal system. The recent discoveries in connection with electron oscillators and electron multipliers open up possibilities of developments which may go far towards a more satisfactory solution of the television problem in the future. At the same time we must not lose sight of the remarkable advances that have been achieved in television during the last few years, nor withhold our admiration for the technicians who have made possible the extraordinarily good emissions which now appear from the London Station.

PICTURE UNITS, SCANNING LINES AND FREQUENCIES.

Requirements for the New Television Service.

The Postmaster-General's Television Advisory Committee has suggested that a television picture should not be inferior to a standard of 240 lines and 25 pictures per second—that is to say, eight times the number of lines and twice as many pictures per second as the old 30-line low definition television. This may seem a big step, but definitions up to 700 lines have been demonstrated. The increased definition, too, would seem to sound the death knell of mechanical scanning methods but, as will be explained later, these have been developed to a high stage of perfection and may even prove cheaper than electronic methods of reception.

The shape of the picture in the Baird transmissions is a rectangle with a ratio of width to height of 4 to 3. This 4 to 3 ratio is that of the old silent films. The

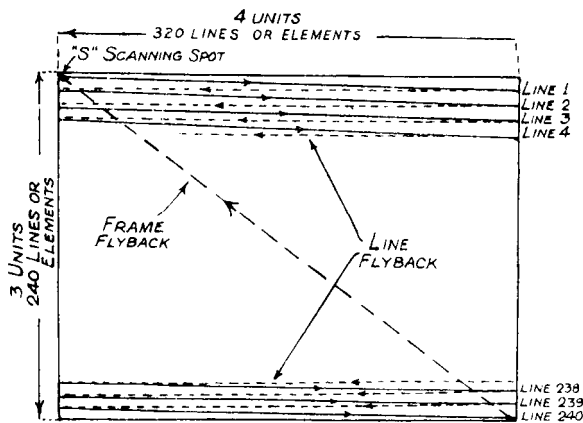

FIG. 2.—SEQUENTIAL SCANNING.

shape of the picture in the Marconi-E.M.I. transmissions is a rectangle with a ratio of width to height of 5 to 4, this being exactly the ratio of modern talking films, so that there should be no waste of picture area when transmitting these.

Sequential Scanning. Before progressing further the various relationships of line scanning and picture ratio will be examined. The Baird system uses "sequential" scanning, i.e. one line following another in progressive sequence. Fig. 2 represents

the top and bottom portions of the scanned area with the distance between the lines considerably enlarged. Thus to scan the 4 by 3 picture area the scanning beam "S" starts at the top left-hand corner and moves across this area from left to right horizontally,

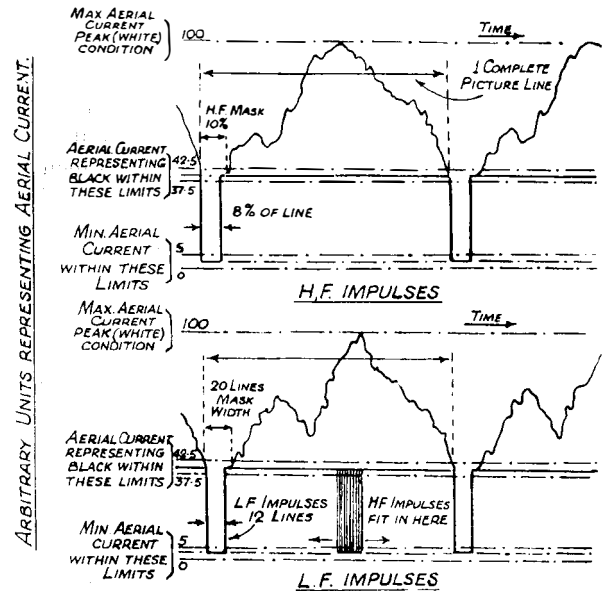

FIG. 3.—WAVEFORM OF TRANSMITTED SIGNAL, SEQUENTIAL SCANNING SYSTEM.

being 4 units long or equivalent to 320 picture elements ($240 \times 4/3$). As the frame scanning motion, which moves the horizontal line scan downwards, is operating during this time, the end of line 1 will be nearly $1/240$ th part of the picture depth lower than the start of the line. On arriving at the right-hand side of the area the beam is returned to the left-hand side in 8 per cent. of the time taken for a line traversal, making the path of the "fly-back" practically horizontal. (Shown dotted in figure.) During this time a line-synchronising impulse is injected into the scanning circuit to keep the transmitter and receiver in step. The scanning beam is again on the left-hand side but one picture element ($1/240$ th of the screen depth) lower down than the preceding line. The second line is then scanned, describing a path exactly parallel with that of the first and immediately below it. This process is repeated so that the picture area is scanned in 240 successive lines from left to right and top to bottom, the scanning beam finishing in the bottom right-hand corner of the area after one complete picture or frame scan. The scanning beam is now returned to the top left-hand corner in 5 per cent. of the time taken to scan one picture or the equivalent time of 12 lines. A further 8 lines are masked off to form a black edging, so making the effective number of lines 220. During the frame "fly-back" a frame synchronising impulse is injected into the scanning circuit. At the conclusion of each line "fly-back" a further 2 per cent. of the picture area is masked off to form a black edging, making 10 per cent. in all, so reducing the effective width of the picture to $320 - 32 = 298$ picture elements.

The waveform of the transmitted signal, shown in

terms of D.C. working, is illustrated in Fig. 3. Using the arbitrary aerial current units of zero to 100, the total modulation for synchronising extends between the tolerance limits of zero to 5 and 37.5 to 42.5,

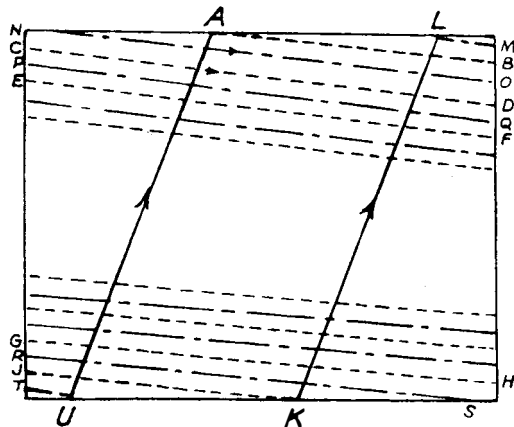

FIG. 4.—INTERLACED SCANNING.

while the picture modulation (black to white) extends between the tolerance limits of 37.5 to 42.5 and 100.

Interlaced Scanning. The Marconi-E.M.I. system is a little more difficult to understand. This system transmits 25 complete pictures per second, each of 405 total lines. These lines are so interlaced that the frame and flicker frequency is 50 per second. The line frequency will then be 10,125 lines per second, or 405×25 . Two frames, each of 202.5 lines, are interlaced to give the total of 405 lines with a complete picture speed of 25 per second.

This may best be described with the aid of Fig. 4, which represents the top and bottom portions of the scanned area with the distance between the lines considerably enlarged. The line scan is left to right as before, also top to bottom with a quick return. The combination of the two motions produce the slightly sloping scanning lines. Starting at A, not necessarily at the beginning of a line, the spot completes the line AB, flies back in 10 per cent. of the line scan time ($1/10,125$ secs.) and traverses line CD and so on down the "dotted" lines of the drawing. At the bottom of the frame the spot travels along line GH, followed by JK. At this point the return stroke of the frame motion begins and returns the spot to L at the top of the frame, taking the equivalent time of 10 scanning lines. A complete frame scan has been made since leaving A, so that $202\frac{1}{2}$ lines have been completed and the point L is half a line away from A.

The line scanning is still carried on during this time and the single-line motion JKLM completed. The spot returns to the left and traces out line NO, which, due to L being half a line ahead of A, will be between lines AB and CD. Similarly the next line PQ will lie halfway between CD and EF, these interlacing lines being shown chain-dotted to RS and finally to TU, at which point the frame return causes the spot to rise again to point A.

During this time two frames will have been scanned occupying the time of exactly 405 complete lines, after which the cycle begins again.

The waveform of the transmitted signal, the carrier

of which is amplitude modulated, with a carrier value proportional to the D.C. component, as in the Baird waveform, is illustrated in Fig. 5. Signals below 30 per cent. of peak carrier represent synchronising signals, these being rectangular in shape and extending downwards to effective zero carrier.

Vision signals occupy values between 30 per cent. and 100 per cent. of peak carrier.

The two systems are summarised and compared in the table below:—

Particulars	System	
	Baird	Marconi-E.M.I.
Number of lines (nominal) ..	240	405
Number of lines (effective) ..	220	385
Type of scanning ..	Sequential	Interlaced
Ratio of width to height ..	4 to 3	5 to 4
Frame and flicker frequency ..	25	50
Picture frequency ..	25	25
Line frequency ..	6,000	10,125
Number of line-synchronising impulses ..	1 between each line	1 between each line
Portion of line occupied by synchronising impulses ..	8%	10%
Number of frame synchronising impulses ..	1 between each frame	6-12 between each frame
Portion of frame occupied by synchronising impulses ..	5%	Approx. 5%

Frequencies Involved. The Baird picture shape of 3 units height to 4 units width gives the number of units composing one line as being $240 \times 4/3 = 320$. One way of looking at this is to view the area as being made up of small square units of which there are 240 in the height and 320 in the width. This means that the area is composed of 240×320 or 76,800 scanning units, which is 36.6 times more than in the 30-line television broadcasts. Therefore the definition will be 36 times better than previously if all the range of

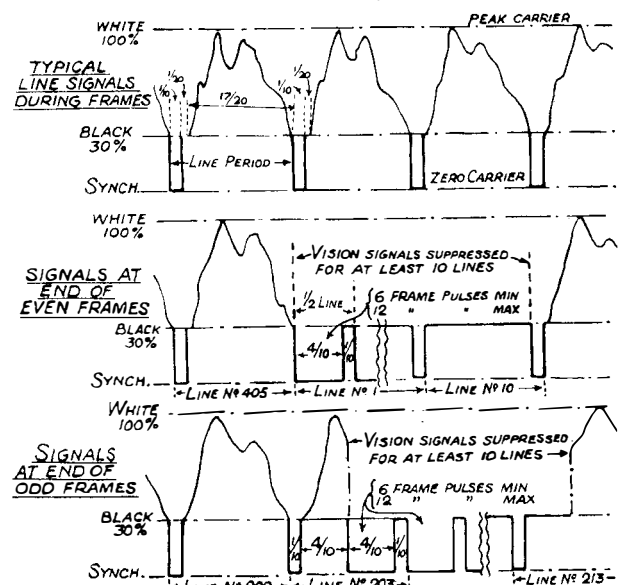

FIG. 5.—WAVEFORM OF TRANSMITTED SIGNAL, INTERLACED SCANNING SYSTEM.

frequencies can be embodied in the picture. The greatest difference between any two sequential scanning units is that of minimum to maximum illumination, or, black to white as viewed. The maximum frequency generated in one scan, then, is half the number of scanning units, i.e. $76,800/2 = 38,400$.

There are, however, 25 complete scans per second, so that the generated frequency becomes $38,400 \times 25 = 960,000$ cycles per second, which is practically one megacycle per second. The frequency for any number of lines, picture ratio and pictures per second may be calculated from the formula :

$$\frac{\text{lines}^2 \times \text{width} \times \text{pictures per sec.}}{\text{height} \times 2} = \text{maximum frequency}$$

Calculating the frequencies transmitted by the Marconi-E.M.I. system the following result is obtained :—

$$\frac{405 \times 405 \times 5 \times 25}{1 \times 4 \times 2} = 2,562,890 \text{ c.p.s.}$$

$$= 2,563 \text{ kc.p.s.}$$

For the purpose of wireless broadcast these frequencies have to modulate a carrier wave so that the total frequency spread required on a radio channel will be approximately $2\frac{1}{2}$ megacycles per second, or two and a half million cycles per second.

A high quality sound broadcast may be obtained with modulating frequencies up to 10 kc.p.s. and a total band width of 20 kc.p.s., so that it will be seen that a 240-line television system would occupy as much space as 100 sound broadcasting stations. This explains the impossibility of accommodating such a system in the medium-wave broadcasting band. A broadly tuned radio receiver has a fairly uniform response when detuned 1 per cent. either side of the carrier frequency. Thus 1 per cent. detune either side of a carrier frequency of 1 megacycle per second, i.e. a wavelength of 300 metres, gives a band width of 20 kc.p.s., while the same 1 per cent. detune either side of a carrier frequency of 50 megacycles per second, i.e. a wavelength of 6 metres, gives a band width of 1,000 kc.p.s. This is much more like the frequency values required, so that it is only in the region of the so-called "ultra-short waves" that the great spread of frequency can hope to be accommodated.

Circuit design has resulted in receivers having a $2\frac{1}{2}$ megacycle per second response, such a circuit being shown in the second part of this article.

TRANSMISSION SYSTEMS EMPLOYING MECHANICAL SCANNING.

Spotlight Method (Baird).

The spotlight method is a direct development of Baird's original patents and is used chiefly for close-up or three-quarter-length images showing announcers giving educational talks, lectures, etc. The television signal is instantaneous and generated in the following way.

A high intensity arc giving an intense source of light is focused on to a mask having a cut-out corresponding to the picture ratio, i.e. 4 : 3. This area is evenly illuminated. In order to accommodate the large number of scanning lines, 240, the scanning

disc has to be of a sufficient diameter. The disc has a series of 240 small apertures pierced through it near the periphery, the holes in series forming a spiral trace. The disc runs in a vacuum case to reduce air resistance and keep the apertures clean.

The cut-out mask is located between the source of light and the disc, being arranged so that the perfora-

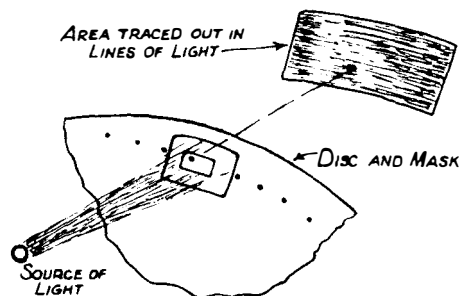
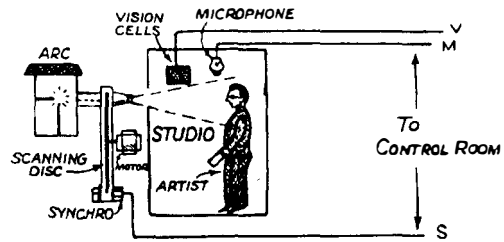

FIG. 6.—SPOTLIGHT METHOD OF SCANNING.

tion nearest the periphery of the disc describes a line along the top edge of the mask cut-out when the disc is rotated in a clockwise direction, viewed from the light source. The aperture following the first is spaced from it such that after the first aperture has just left the mask area the second aperture begins to describe a line, also from left to right, immediately below that described by the first. As the disc rotates, then, the spiral series of 240 equidistant holes scan the mask cut-out in 240 lines, one complete scan being accomplished in one revolution of the disc. From the foregoing it will be seen that the size of the perforations in the disc are interdependent with the diameter of the disc and the size of the mask cut-out area.

The light from the arc passes through each perforation in turn as it is exposed to the lighted area of the mask cut-out, and will illuminate any object in its path. With the rotation of the disc the object is scanned with 240 lines and at a rate of 25 complete scans per second. The light reflected from the scanned object is picked up by four large photo-electric cells placed in a rectangular formation in front of the scanned object so that the scanning beam is not interfered with. In this way the maximum photo-electric effect is gained from the reflected light. In the photo cells the light is converted into an electric current varying in sympathy with the varying amount of reflected light supplied by the action of the scanning beam. This current is amplified and finally modulates the radio carrier wave. The area of light found by the scanning action is not exactly rectangular, but owing to the large diameter of the scanning disc the lines can, to all intents and purposes, be looked upon as straight horizontal ones.

Fig. 6 gives a pictorial representation of the spotlight method of scanning. The sound side of the programme is picked up in the usual manner by means of a microphone.

As explained previously every received television picture has to be synchronised exactly with the transmitter and synchronising signals have to be generated by the scanning apparatus so that they can be superimposed on the picture modulation signal for this purpose.

Low frequency pulses at 25 per second are needed for frame synchronisation and high frequency pulses at 6,000 per second (240×25) for the line synchronisation. These are generated by having the requisite number of slots cut in the scanning disc, distinct from the scanning apertures themselves, and placing a source of light behind these and allowing the chopped or interrupted light to focus on a single photo cell. These pulses are amplified and injected into the vision signal in the control room.

Film Scanning by the Spotlight Method.

Talking films may also be scanned by a modification of the spotlight method. Fig. 7 shows the system schematically. Light from the projection lamp or arc is concentrated by a condenser on to the film gate of a converted standard talking picture projector. In normal talking film practice the film moves through the gate intermittently, one frame at a time, at a speed of 24 frames per second. For the purpose of television transmission this speed is increased to the standard of 25 frames per second, and in the Baird film scanner the film is drawn continuously through the gate. By this means the vertical scanning is accomplished, leaving only the horizontal, or line scanning, to be accomplished.

The continuously moving picture is focused by means of a lens on to a cut-out mask as before. Behind the cut-out is the scanning disc as before except that instead of the perforations in it forming a spiral to give both a vertical and horizontal scanning action the 240 perforations are set out equidistantly around a common circle.

The speed of the disc-driving motor is as before, i.e. 1,500 revolutions per minute, and the motor is interlocked either electrically or mechanically with the projector motor so that the film and disc speeds are the same, i.e. 25 frames per second. The light passing through the scanning apertures is focused on a photo-electric cell, the resulting current being amplified for transmission as usual.

On analysing the scanning action it is seen that if the picture were stationary on the cut-out mask that strip portion of the picture over which the perforations of the scanning disc pass would be scanned 240 times in the course of one revolution of the disc. If, after one perforation of the disc had scanned the particular line of the picture, the picture be moved upward $1/240$ th of its length a line alongside and below the previous line would be scanned. If this is repeated 240 times, then, the whole picture can be scanned in the time taken by one revolution of the scanning disc. The sound track on the film is dealt with as in talking film projection, the increased speed of the film giving a slightly higher pitch to the sound, but this is not

obvious. The synchronising signals are generated as before.

Another type of Baird film scanner utilises a Farnsworth electron multiplier in place of the photo cell, and a much larger output with a smaller projection illuminant can be obtained by this means.

In yet a later type of film scanner the scanning disc is replaced by an electronic horizontal scanner. This and the electron multiplier will be explained later.

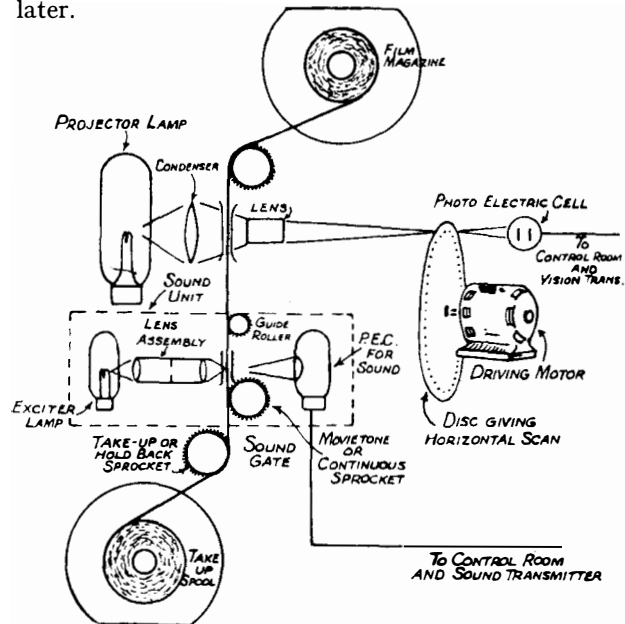

FIG. 7.—FILM SCANNING BY THE SPOTLIGHT METHOD.

Intermediate Film System.

For large interior and, particularly, exterior shots the intermediate film system of transmission has been developed by the Baird company. This is an extension of the film scanning system. The exterior shot is first taken by means of a sound film camera using 17.5 mm. specially sensitive film, the sound track being recorded at the same time on a narrow strip of the film between the sprocket holes and the edge, using the variable density method of recording. The film is then passed into a series of separate tanks over guide rollers wherein it is treated photographically by chemicals to develop, fix and wash it.

While still wet the film is passed into a film scanner and scanned as detailed before. In order to reduce the number of perforations in the scanning disc and position them with greater accuracy, the disc may have 120 holes in it at 3 degrees angular spacing instead of 240 holes at $1\frac{1}{2}$ degrees angular spacing, the speed being increased to twice the previous amount, i.e. from 1,500 revolutions per minute to 3,000 revolutions per minute. It will be seen that the equivalent of 240-line scanning is so obtained. Sound signals and synchronising are carried out as usual.

The main feature of the intermediate film system lies in the fact that a delay of only 30 seconds is introduced between the actual filming of the event and its actual transmission as a television signal. After scanning the film may be dried and stored for any future use. A photograph of the Baird Intermediate Film Transmitter is given in Fig. 8.

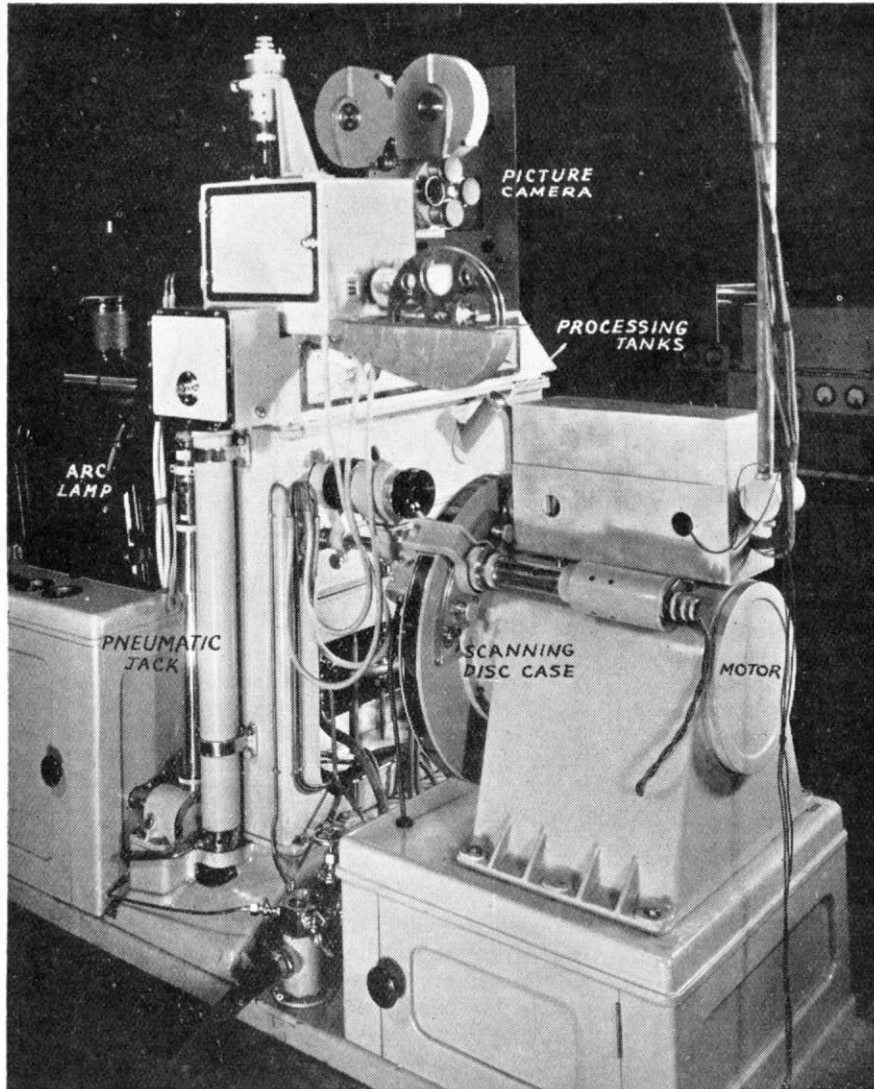

FIG. 8.—BAIRD INTERMEDIATE FILM TRANSMITTER.

The apparatus is not unduly bulky and could be mounted in a van and used to transmit from any outdoor events. Fig. 9 gives a schematic view of an intermediate film transmitter. In the Fernseh-A.G. system of intermediate film transmission, the film after being scanned is passed into a bath, where the emulsion is washed off the film, the film dried, re-coated with emulsion, re-dried and fed into the film camera for further use. The film used is in a continuous loop, this being a great advantage both from the cost and size standpoint when it is realised that about 5,000 feet of film would otherwise be necessary for one hour's television transmission.

TRANSMISSION SYSTEMS EMPLOYING ELECTRONIC SCANNING.

The Image Dissector or Electron Camera and the Electron Multiplier.

The principle of the electron camera is shown by Fig. 10 and consists essentially of a cylindrical

vacuum tube, one end of which is coated on the interior surface with a photo-electric material, and is connected to a negative potential. The photo-electric layer is translucent, as it is in a very fine layer on a conducting backing. On this layer is focused by means of a lens the optical image of the scene to be transmitted.

At the other end of the tube there is a circular anode punctured at its centre with a small aperture A, square in shape and of size equivalent to one picture element. The action of the light on the photo-electric material negatively charged causes electrons to be drawn towards the circular anode under the influence of electrostatic acceleration. Owing to the irregular nature of the surface of the photo-electric layer these electrons would leave the surface at all angles and means have to be made to correct this tendency in practice. Let it be considered for the present that the electrons leave the cathode at right angles; then an electron image of the original picture will be thrown on the anode, that is to say, if a fluorescent screen were placed in the path of the electrons or upon the anode, it would light up with the same tone distribution as the original optical image.

An electron can be deflected from its path either by an electromagnetic or an electrostatic field, and to produce a scanning motion to the beam of electrons

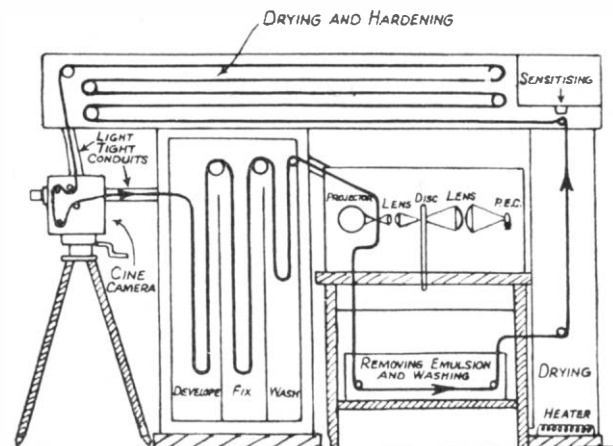

FIG. 9.—SCHEMATIC VIEW OF AN INTERMEDIATE FILM TRANSMITTER.

suitably placed deflector plates fed with scanning potentials via the leads x , x^1 , y , y^1 can be used in exactly the same way as the electron beam in a cathode ray tube.

The speed with which the electrons shoot towards the anode is such that those in the path of the aperture pass straight through and can be collected on an additional electrode behind the anode, yielding an

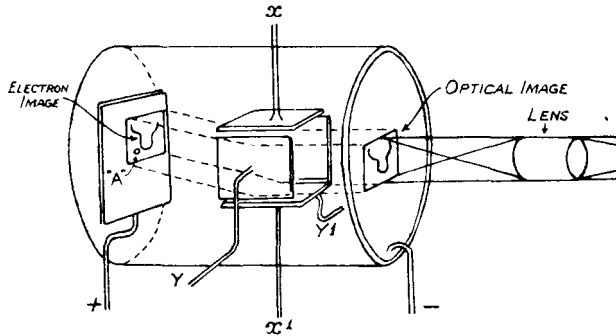

FIG. 10.—PRINCIPLE OF THE ELECTRON CAMERA.

electrical signal corresponding to the density of the electrical image at that point. The electron image is scanned, then, by moving the electron picture from right to left and top to bottom, which is, in effect, moving the picture over the aperture instead of the aperture over the picture as in the previously mentioned scanning systems.

In practice the electron beam is kept in a parallel path by using high anode potentials, thus increasing the electron acceleration, and by winding a layer of wire around the outside of the tube, thus forming a solenoid along its length when a suitable current flows in the winding. In a magnetic field a moving electron behaves exactly as a current-carrying conductor; if its direction lies absolutely parallel there is no force on it, but if it tends to move sideways or cross the field a force proportional to its sideways velocity acts upon it and keeps it in a parallel path. The action is far more complicated than this, actually, as the electron is given a circular motion as well as motion parallel to the field.

Scanning is, in practice, carried out by two pairs of magnetic deflector coils placed outside the tube such that their resulting fields can give the required scanning motion when suitable saw tooth voltages are applied to them. The respective positions of the various coils can be seen in Fig. 11.

It will be realised that the scanning aperture is exceedingly minute and the value of the electrons passing through it would give a current so small as to be lost amongst the various valve noises of any normal amplifying circuit. Amplification of these minute currents is made possible by the Farnsworth electron multiplier which is built into the electron camera assembly.

The aperture anode of the electron camera described is replaced by a spun silver disc fitted very tightly into the tube. In the centre of this anode is fitted a protuberant aperture pointing towards the neck of the tube in which is situated the multiplier. Directly behind the anode is a silver disc, fitted in the neck of

the tube, in which the scanning aperture is punched. The disc also forms one of the multiplier cathodes, another cathode being about six centimetres away at the far end of the neck. A ring anode is situated between these two cathodes.

In the electron multiplier, use is made of the high secondary emissive properties of caesium. If an electron impinges with sufficient force on to a caesium-coated surface then secondary electrons are released. With caesium the secondary emission ratio is 6 to 1, i.e. for every electron striking the coated surface six secondary electrons are emitted.

In the electron multiplier the cathodes are composed of nickel coated with caesium. Now if an electron from the electron camera escapes through the aperture into the electron multiplier it is accelerated down the tube by the action of the ring anode. Around the multiplier tube is wound a solenoid as before, which keeps the electron in a parallel path. The resultant effect is to cause the electron to shoot through the ring anode and strike the caesium-coated cathode, releasing six secondary electrons. A radio-frequency potential (50 megacycles per second or more) is supplied to the cathodes in order to accelerate the electrons and so make their impacts sufficient to release secondary electrons.

The six secondary electrons, under the influence of the radio-frequency potential and the ring anode, shoot back along the multiplier tube, their acceleration being sufficient to carry them through the ring anode and strike the apertured caesium-coated cathode. Again for each of the six electrons six more secondary electrons are emitted, i.e. 36 in all. These shoot to the other end again and each releases six more secondary

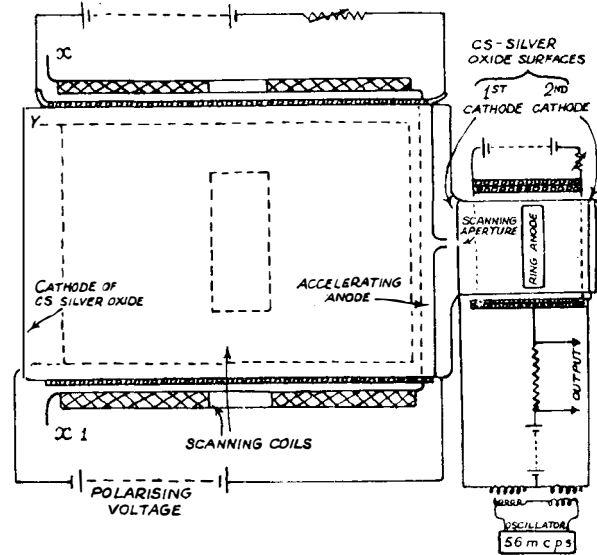

FIG. 11.—ELECTRON CAMERA.

electrons, i.e. 186 in all. Thus in a few oscillations an appreciable current is generated, and if the effect were left to develop, a current of amperes would result and burn out the tube. To prevent this, and collect the results of the electron amplification, a quenching frequency is applied to the radio-frequency oscillator, the quenching frequency being dependent upon the

amplification desired. The amplification is distortionless and the system holds great possibilities. Farnsworth is building in America a television station with

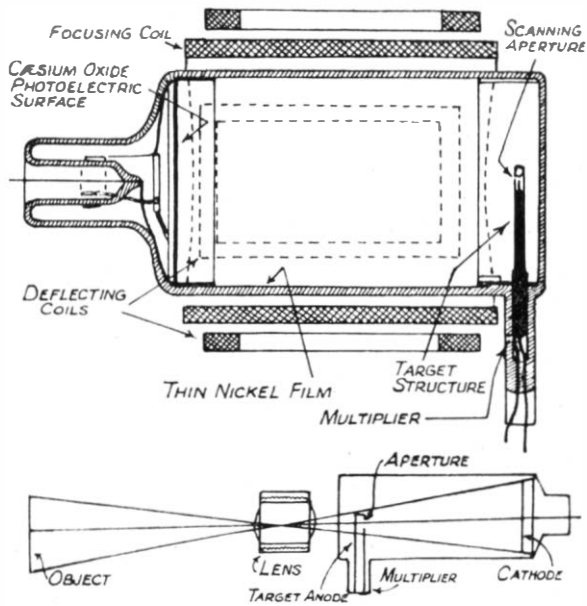

FIG. 12.—ANOTHER TYPE OF ELECTRON CAMERA.

two cold cathode electron multipliers in push pull, developing a 20 kW output. Tubes of this type are, of course, water cooled.

Another type of electron camera is shown in Fig. 12. A tubular target anode at the front end of the tube is used, the anode having the scanning aperture punched in the side facing the photo-electric cathode.

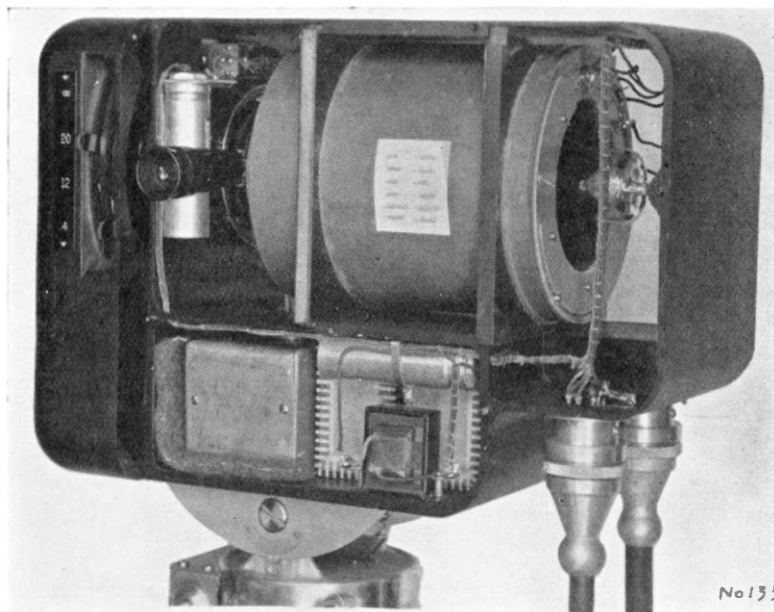

FIG. 13.—FARNSWORTH ELECTRON CAMERA.

The cathode is of the usual construction, caesium oxide on a spun silver disc. The optical image is focused down the length of the tube on to the cathode by using a long focus lens so that the anode is out of

focus. The electrons passing through the perforated anode, proportional to the light density of the picture element being scanned at that instant, are amplified by a small electron multiplier built into the target anode. The usual methods of electromagnetic focusing and deflection are used employing coils wound outside the tube. Such a camera, produced by Farnsworth, is illustrated in Fig. 13.

When the film scanner was explained, reference was made to a photo-electric cell working on the electron multiplier principle. In this case the light from the scanning disc is allowed to fall on to one of the caesium-coated cathodes and the resultant released electrons multiplied in the tube.

Another type of film scanner uses an electron camera with an electron multiplier, the horizontal deflecting coils only being operated giving a horizontal scan, the vertical scan being given by the motion of the film.

The Iconoscope.

This device is a combination of photo cell and cathode ray tube, being the invention of the American scientist Zworykin. Television research has always held the human eye as being the perfect scanning system and the composition of the Iconoscope closely resembles that of the eye, the innumerable photo-sensitive cells composing the photo-electric mosaic corresponding to the rods and cones of the retina of the eye. The nerve impulses due to the action of light on each of the rods and cones, however, operate the brain simultaneously over an equivalent number of transmission channels, but in its electrical counterpart only one transmission channel is available, so that the electrical impulses from each element of the mosaic have to be transmitted in a definite serial order.

This special form of cathode ray tube is shown in Fig. 14. The glass envelope is of a somewhat different shape from the normal cathode ray tube, being spherical in shape above the neck, and having a square plate, supported by a glass assembly, inserted from one side at such an angle that a picture may be focused upon it from the exterior and the electron beam in the interior.

The plate consists of a sheet of very thin mica having a metallic coating on the back to which a wire lead passes through the glass envelope and plate assembly. This is termed the signal plate and, on the side exposed to the electron beam, has its face sprayed with minute silver globules each of which is photo-sensitised with a suitable photo-electric material such as caesium. A photo-electric mosaic is thus formed, each globule in effect constituting a separate photo-electric cell, it being estimated that there are some three million elements on the mica sheet.

The electrical action of the Iconoscope may best be explained with the aid of Fig. 15a which shows the various parts in their actual physical relationship. PC is the photo-electric cathode formed by the

mosaic while PA is the anode of the photo-electric combination, in practice this being a metal coating on the wall of the tube. The photo-electric material is insulated from the back metal plate by the mica sheet but has a capacitance to it shown by the condenser C.

The circuit may be reduced to the conventional photo-electric cell circuit as shown in Fig. 15b. When light from the picture to be transmitted falls on the mosaic each element of it, represented by PC, emits electrons and charges the condenser C. When the electron beam, in the course of its scan of the mosaic area, impinges on a photo-electric element, that element receives electrons from the beam and discharges, or partially discharges, the condenser. The discharge current depends on the charge on the photo-electric condenser element and, therefore, on the light intensity on that particular element. The charge and discharge currents of the condenser are transformed into signal voltages across the resistance R and applied to the grid of the first amplifying valve.

Since the scanning beam and optical image strike the same side of the mosaic, it is impracticable for the axis of both the electron gun and the lens to be at right angles to the mosaic plate. The plate is set perpendicular to the optical axis of the lens, since a standard lens is used, resulting in the scanning beam tending to give a keystone patterned scan.

This effect is counteracted by a slight alteration in the scanning potentials fed to the magnetic deflecting

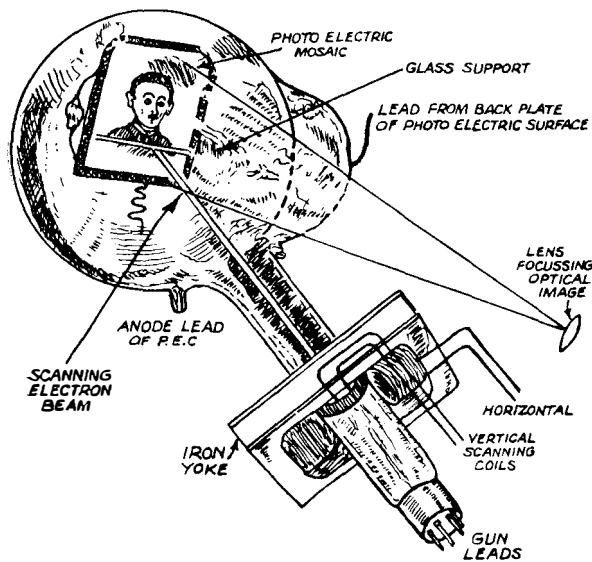

FIG. 14.—THE ICONOSCOPE.

coils which surround the neck of the tube. The electron beam is produced by a hot filament or cathode which emits electrons in the same way as a wireless valve. The filament is surrounded by a negatively charged shield which helps to concentrate the electrons

into a beam flowing towards the first anode, the positive potential of which attracts them. A small hole in the centre of the anode allows a fine beam of electrons to escape through it, due to their acceleration. Deflection of the beam is carried out by two pairs of magnet coils mounted at right angles to each other on a common yoke. The coils are fed with suitable scanning potentials from a time base.

The resolution of the Iconoscope is actually better than the rest of the system is capable of transmitting, and it is therefore possible to scan an area considerably smaller than the full size of the Iconoscope plate. By changing the horizontal and vertical scanning amplitudes simultaneously the effect of moving the camera forward or away from the subject is obtained without any movement of the actual camera. If the scanning beam be adjusted to scan only a particular part of the mosaic, the effect of turning the camera may also be obtained.

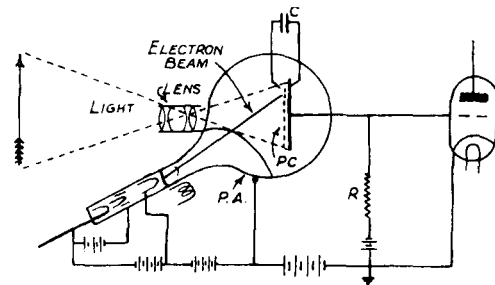

FIG. 15a.—PRINCIPLE OF THE ICONOSCOPE.

The whole Iconoscope assembly is built into the form of a camera and as such is portable, being used for both internal and external shots.

In this country it has been developed to a high state of perfection by the Marconi-E.M.I. organisation and is in regular use at the London Television Station both for direct scanning and for film scanning. For

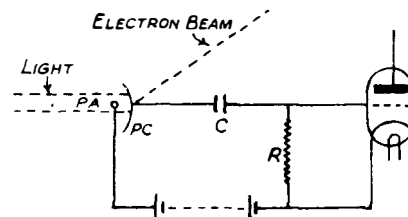

FIG. 15b.—THE CIRCUIT OF THE ICONOSCOPE.

the later purpose an intermittent film motion is used as in the normal film projector.

In the foregoing television transmission systems those systems likely to be most used in this country have been explained. Other scanning systems have been developed, notably by Scophony, Ltd., who use a high speed lens wheel for film scanning and a rotating echelon for floodlight scanning.

Loewe in Germany has also produced a film scanner for interlaced scanning having two sets of holes in the disc, one of which is masked alternately by another disc. The film moves continuously.

The Variation of the Holding Times of Telephone Calls

E. D. GLAZIER, B.Sc. (Eng.)

A brief exposition of the exponential holding time theory and its application to practical problems.

WHERE no restriction is placed upon the holding times of telephone calls such as local calls, it is found that these holding times follow very closely an exponential law. Thus the probability that a particular call chosen at random has a holding time greater than t units is given by $P_{> t} = e^{-\frac{t}{h}}$ where e is the base of natural logarithms and h is the average holding time of all calls measured in the same units as t .

Exponential Law.

This law may be shown to follow from the two fundamental assumptions given below:—

1. The probability that a particular call in progress will terminate in a short interval of time, is independent of the length of time the call has been in progress.
2. The probability that a call in progress will terminate in a short interval of time, is dependent only on the length of this short interval measured in terms of the average holding time.

Hence, from the latter assumption, the probability that a call in progress will terminate in a time dt is given by dt/h , and the probability that it will not terminate in dt is $(1 - dt/h)$.

By assumption 1, the law of independent probabilities may be used to find the probability that the call will not terminate in two consecutive intervals;

$$\text{this probability} = \left(1 - \frac{dt}{h}\right)^2$$

In a time t measured from the origination of the call there will be t/dt intervals and the probability that the call will not terminate in time t is given by

$$\left(1 - \frac{dt}{h}\right)^{\frac{t}{dt}}$$

Hence the probability of a holding time longer than t ,

$$\begin{aligned} P_{> t} &= \text{Limit}_{dt \rightarrow 0} \left(1 - \frac{dt}{h}\right)^{\frac{t}{dt}} \\ &= 1 - \frac{t}{h} + \frac{1}{2!} \cdot \frac{t^2}{h^2} - \frac{1}{3!} \cdot \frac{t^3}{h^3} \dots \\ &= e^{-\frac{t}{h}} \end{aligned}$$

The distribution of holding times, obtained from a pen record taken at a London exchange, is shown by the circles in Fig. 1, the full line indicating the exponential law. The proportion of calls having holding times longer than the average is e^{-1} , or about 37 per cent., whereas the proportion with holding times below the average is 63 per cent.

The use of this exponential assumption leads to much simplification in the mathematical solution of certain problems, for example, delay problems.

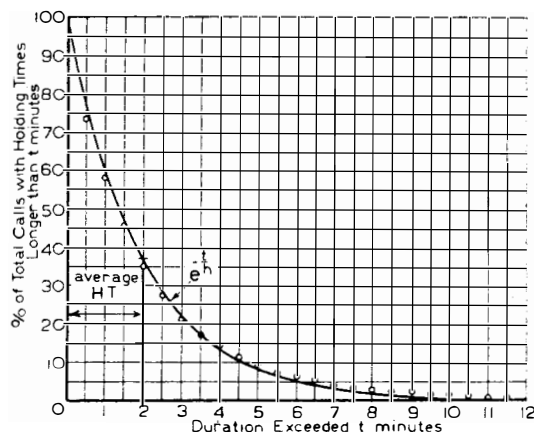

FIG. 1.—DISTRIBUTION OF HOLDING TIMES.

Probability of a Call Continuing Beyond a Time t .

A further property which may be shown to follow from the exponential relation, is that the probability of a call continuing beyond a time t measured from a certain instant is independent of the time the call has already been in progress.

Consider a call which originates at time A and terminates at time B, as shown in Fig. 2. It is

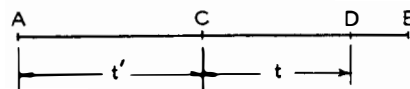

FIG. 2

required to find the probability, that such a call will continue for more than a time t when the origin of this interval is taken from a time C, at t' units after A. Then the following equation may be formed since the probabilities involved are independent of one another.

Probability of a call being still in progress at D

$$= \text{Probability of being in progress at C} \times \text{Probability, if in progress at C, of being still in progress at D.}$$

or $e^{-\frac{t'+t}{h}} = e^{-\frac{t'}{h}} \times \text{Probability, if in progress at C, of being still in progress at D.}$

\therefore Probability of a call which is in progress at C

$$\text{being still in progress at D} = \frac{e^{-\frac{t'+t}{h}}}{e^{-\frac{t'}{h}}} = e^{-\frac{t}{h}}$$

This result is thus independent of t' or the instant at which C is chosen.

Average Duration of Congestion.

The preceding results enable the average duration of congestion in a group of n switches to be calculated. Consider the call sequences and durations depicted in Fig. 3. The n switches considered are all

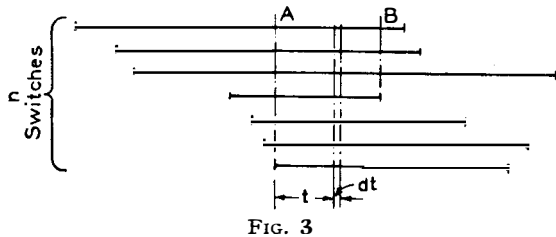

FIG. 3

engaged during the interval from A to B. The probability of the n calls all continuing longer than a time t , measured from A, the inception of the last call, is

$$\left(e^{-\frac{t}{h}}\right)^n = e^{-\frac{nt}{h}}$$

The distribution of congestion periods is thus also exponential.

The probability of the n calls continuing longer than $t + dt$ is $e^{-n \cdot \frac{t+dt}{h}}$. \therefore Probability of one or more of the n calls releasing between t and $t + dt$, or the probability of a congestion time equal to t is $e^{-\frac{nt}{h}} - e^{-n \cdot \frac{t+dt}{h}}$

$$\begin{aligned} \text{that is } P_{(=t)} &= e^{-\frac{nt}{h}} \left(1 - e^{-\frac{n \cdot dt}{h}}\right) \\ &= e^{-\frac{nt}{h}} \left(1 - 1 + n \cdot \frac{dt}{h} - \frac{1}{2!} \frac{n^2 dt^2}{h^2} \dots\right) \\ &= n \cdot \frac{dt}{h} \cdot e^{-\frac{nt}{h}} \dots \text{ when } dt \text{ is small.} \end{aligned}$$

\therefore Average duration of congestion

$$\begin{aligned} &= \sum_{t=0}^{\infty} t \times P_{(=t)} \\ &= \int_0^{\infty} t \cdot \frac{n}{h} e^{-\frac{nt}{h}} \cdot dt \\ &= \frac{h}{n} \end{aligned}$$

If P_n is the proportion of the busy hour that all n switches are engaged, as determined from the Erlang lost call formula, then the number of occasions on which congestion occurs during a busy hour

$$= \frac{P_n}{n} = \frac{n}{h} \cdot P_n$$

Average time during which x out of n switches are engaged.

The average duration of the condition of x switches out of a group of n being simultaneously engaged can be found by similar reasoning.

Measuring time from the instant that the x^{th} call arrives, the probability that these x switches will be engaged longer than t is given by the product:—

Probability of the x calls not terminating before the end of the interval $t \times$ Probability that no calls will arrive in the time t .

The latter probability depends on the traffic A offered to the switches, and assuming pure chance arrival of calls, the probability is given by $e^{-A \cdot \frac{t}{h}}$. This may be deduced by analogous assumptions to those used in the original deduction.

Denoting the probability that x switches will be engaged longer than t by $P_x (>t)$, then

$$\begin{aligned} P_x (>t) &= \left(e^{-\frac{t}{h}}\right)^x \times e^{-A \cdot \frac{t}{h}} \\ &= e^{-(x+A) \frac{t}{h}} \end{aligned}$$

Similarly $P_x (>t+dt) = e^{-(x+A) \cdot \frac{t+dt}{h}}$

\therefore Probability that the condition of simultaneous engagement of x switches will terminate between t and $t + dt$.

$$\begin{aligned} &= e^{-(x+A) \frac{t}{h}} - e^{-(x+A) \cdot \frac{t+dt}{h}} \\ &= e^{-(x+A) \frac{t}{h}} \left\{1 - 1 + (x+A) \cdot \frac{dt}{h} - \frac{1}{2!} \cdot (x+A)^2 \cdot \frac{dt^2}{h^2} \dots\right\} \end{aligned}$$

or $P_{x(=t)} = (x+A) \cdot e^{-(x+A) \cdot \frac{t}{h}} \cdot \frac{dt}{h} \dots$ when dt is small.

The average duration of this condition

$$\begin{aligned} &= \sum_{t=0}^{\infty} P_{x(=t)} \times t \\ &= \int_0^{\infty} t \cdot (x+A) \cdot e^{-(x+A) \frac{t}{h}} \cdot \frac{dt}{h} \\ &= \frac{h}{x+A} \end{aligned}$$

If P_x is the duration per busy hour of the condition of x switches simultaneously engaged, as determined from the Erlang formula, then the number of occasions per busy hour that exactly x switches are

$$\text{engaged} = \frac{P_x}{h} = \frac{x+A}{h} \cdot P_x$$

For a group of 10 switches carrying 3.43 traffic units, the average lengths of time that various numbers of switches are engaged and the number of occasions per busy hour are given in Table 1; the average holding time assumed is three minutes.

TABLE 1.

X No. of Switches Engaged	PX Probability of X switches being engaged.	Average Duration of the condition of X switches engaged. (Minutes.)	Average No. of Occasions per busy hour that X switches are engaged.
0	0.033	0.875	2.23
1	0.111	0.677	9.84
2	0.191	0.552	20.70
3	0.218	0.467	28.00
4	0.187	0.404	27.80
5	0.129	0.356	21.60
6	0.073	0.318	13.80
7	0.036	0.287	7.50
8	0.015	0.262	3.53
9	0.006	0.241	1.45
n=10	0.002	0.300	0.40

Conclusion.

By the use of methods such as those described, the exponential holding time assumption enables many practical and interesting problems to admit of easy solution. Care must be exercised, however, in the use of formulæ which depend on this assumption when the holding times are constant or nearly so.

Waterloo Bridge—Alteration of Post Office Plant

H. WHENMOUTH

The demolition operations now being carried out at Waterloo Bridge preparatory to the commencement of work on the construction of the new bridge have necessitated extensive alteration to Departmental plant and presented the telephone engineer with a unique problem in underground cable construction. The operations consisted, in effect, of two independent works on the north and south sides respectively. The author describes in this article the work undertaken at the Strand (north) approach to the bridge and will give details of the alterations at the Waterloo Station (south) end in a subsequent article.

General.

THE original structure was built in the period 1811-1817 from designs prepared by John Rennie, and consisted of nine masonry arches, each of 120 feet clear span over the river, and approached from the north by a brick viaduct consisting of sixteen 16-foot arched spans, and from the south by a similar viaduct of forty 16-foot spans.

In 1923 unmistakable signs of sinking were observed at one of the central piers, and in 1924, after traffic had been limited by speed and weight, the bridge was closed for a period for remedial measures. A temporary steel bridge was constructed on the east side of the main bridge. Opportunity was taken by the Department to lay 10 steel pipes under each of the footways on the east and west sides of the temporary bridge, and 17 telephone cables, carrying the majority of the southward feed from the Tandem

recommendation of the responsible advisory body that an entirely new bridge should be constructed was accepted by the London County Council after considerable opposition. The Bill for the reconstruction was, however, defeated in the House of Commons, and in 1932 the London County Council decided that the work of building the new structure should be undertaken irrespective of a Parliamentary grant towards the expense, and further, that the proposals should be modified to allow six lines of traffic instead of the four-line width originally proposed.

The extra breadth required by the new plans necessitated the modification of the approaches to the temporary bridge; at the north side the end span, weighing 1,000 tons, had to be lifted 5 feet, and at the south side the last span swung some 30 or 40 feet in an easterly direction to allow the line of the new bridge to be carried straight through.

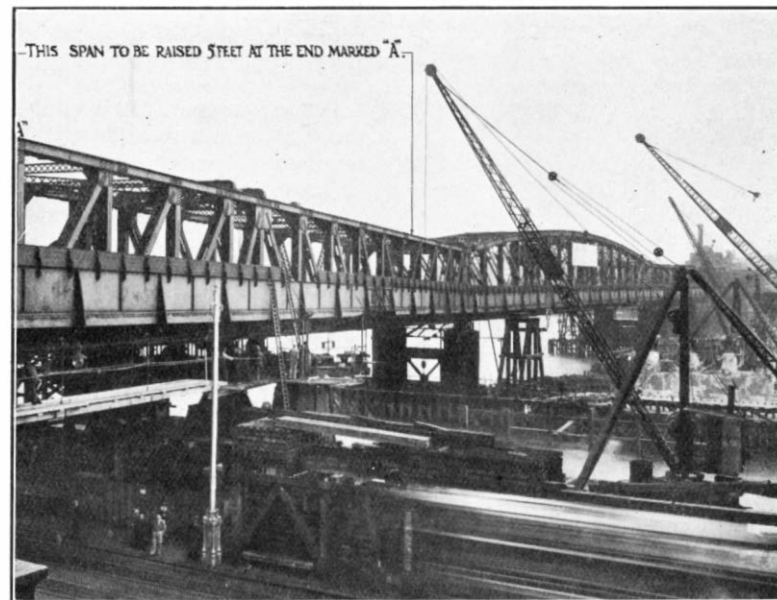

FIG. 1.—GENERAL VIEW OF BRIDGE.

exchange, were diverted into these pipes. When this step was taken it was considered that the cables would remain in these positions until the reconstruction or alteration of the main bridge was completed.

Comprehensive investigation into the condition of the foundations of the piers in the river bed revealed that the weakness could not be remedied by repair of the superstructure, and that the failure was due to the subsidence of the pier foundations. The

Seventeen main cables crossed the temporary bridge, a general view of which is shown in Fig. 1, and it will be realised that the task of providing uninterrupted service on the circuits involved represented a most unusual engineering problem. The conditions were further complicated by the London County Council's decision to straighten the tram subway which passes under the north approach of the bridge and emerges on to the Victoria Embankment at a lower level.

This work, in combination with the reconstruction of the buttresses on which the first arch would be sprung, necessitated the commencement of the diversion of the Department's plant at a point at least 40 yards north of the extremity of the temporary bridge.

route, and the pipes were then brought up to the surface in a temporary wooden manhole C built under the elevated footway, which had been constructed to allow uninterrupted facilities for pedestrian traffic, even during the actual raising of the span itself.

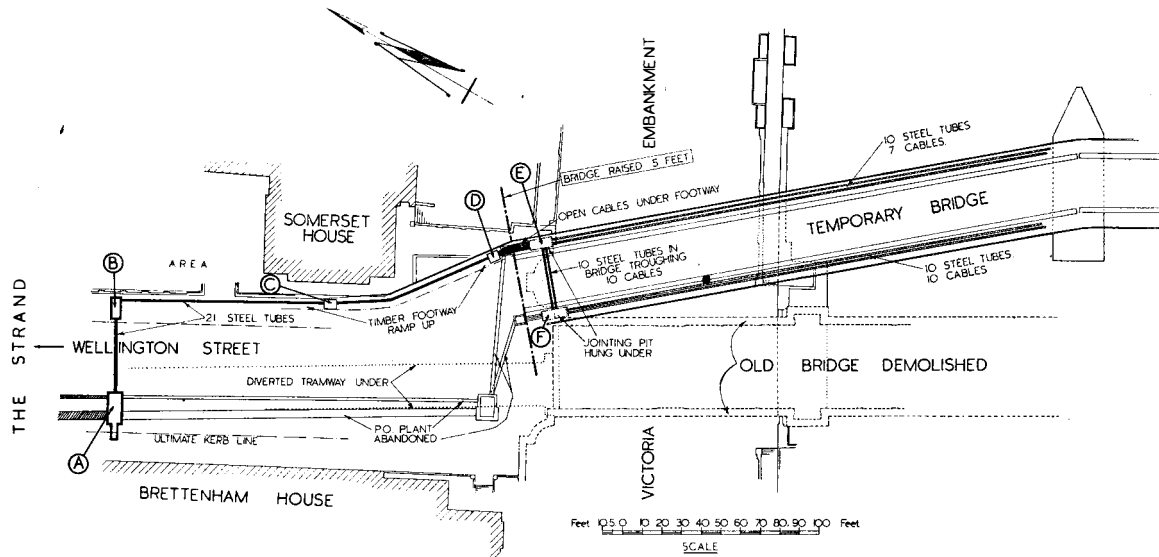

FIG. 2.—PLAN SHOWING POST OFFICE PLANT INVOLVED.

Manhole and Route Construction.

The extent of the Department's work is shown diagrammatically in Fig. 2.

Detailed plans of a specially designed reinforced concrete manhole (incorporating the existing route of 30 steel pipes and a 9-way nest of ducts feeding from the Strand), which was constructed in the dip of the supporting arches at A, are shown in Fig. 3. From this point 21 steel pipes were laid across to a smaller manhole at B, introduced to take the bend in the

Steel pipes were then laid open under the ramp in three tiers of 7 pipes each, on a slope rising to 2 ft. 6 ins. above ground level at the point D. The level of 2 ft. 6 ins. was chosen so that the amount of slack left on the cables to permit the 5 feet upward movement of the bridge should be reduced to the minimum.

Two 12 ft. by 5 ft. by 4 ft. jointing pits were hung under the footway at the points E and F, and were connected by 10 steel pipes laid in the steel troughing

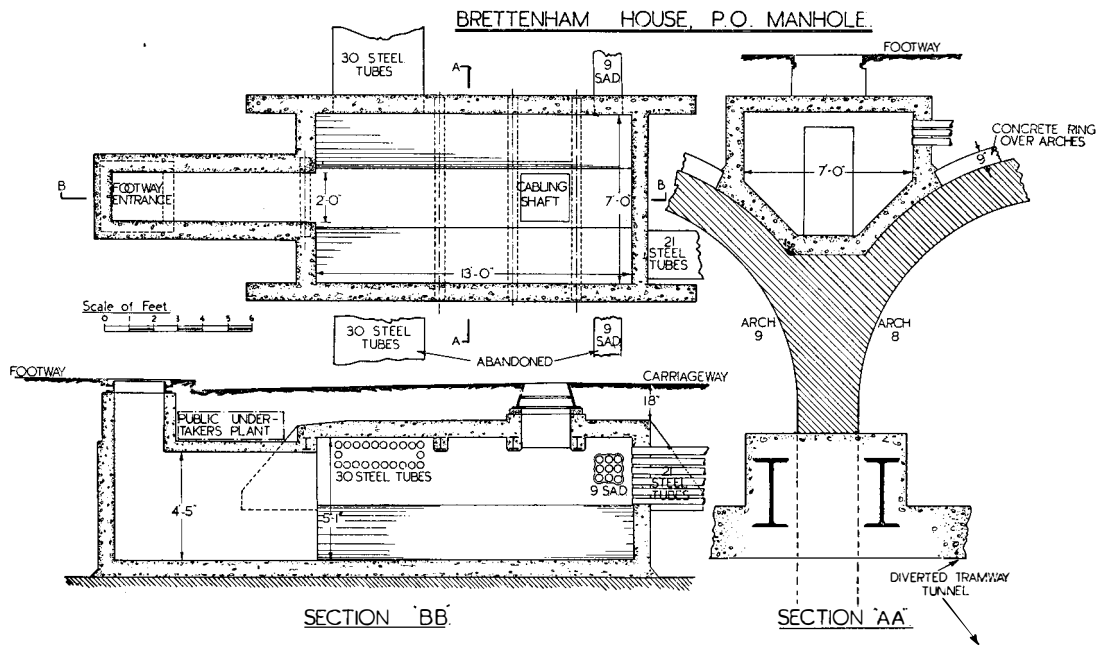

FIG. 3.—DETAILS OF SPECIALLY DESIGNED REINFORCED CONCRETE MANHOLE.

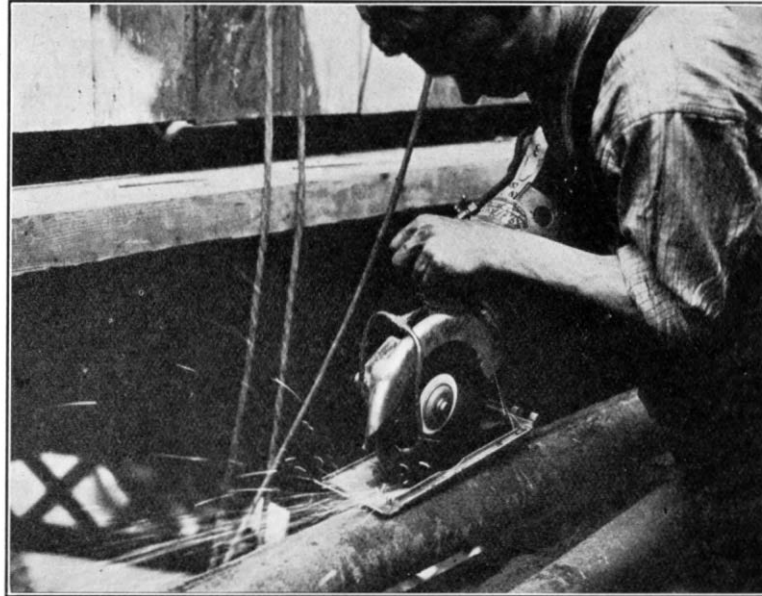

FIG. 4.—ELECTRICALLY-DRIVEN SKILSAW STEEL-CUTTING MACHINE IN OPERATION.

which formed a part of the support of the actual road surface.

The building of the manhole at A was complicated by the existence of the arches under the roadway and the alterations being undertaken in connection with the straightening of the tram subway. It was necessary to strip the two adjacent arches and to add a 9-inch layer of concrete over the whole of the brickwork, as it was feared that the removal of the cushion of earth previously existing under the road surface would result in too direct a strain being thrown on to the arches.



FIG. 5.—COMPLETED JOINTS IN MANHOLE OUTSIDE BRETENHAM HOUSE.

Cabling and Jointing.

It was undesirable to have intermediate joints between the manhole at A and the jointing pits under the bridge footway, if this could be avoided. The cable drums were set up at D and the cables "fleted" through B to the manhole at A. The back ends of the cables were removed from the drums and led away from the bridge along the terrace of Somerset House. The bights of the cables were then turned back and drawn through to the jointing pits at E and F, sufficient slack being left at D to allow the upward movement of the bridge to be made at this point. The existing cables at A, E and F had to be stripped of the encasing steel pipes, numbering 27 pipes in all. It will be apparent to those engineers familiar with this class of work that such extensive longitudinal splitting of pipes containing live cables presented a problem, the solution of which was made more difficult by reason of the close formation of the pipes in the bridge structure and the confined space available for the use of cutting tools. In these circumstances, it was obvious that the time factor would not permit the use of the normal cutting method in which the tubes are cut with a diamond pointed chisel, particularly as it was desired to split the pipes for a minimum length of approximately 7 feet each.

Several firms were approached with a view to the discovery of some suitable power-driven cutting machine, and it was decided to experiment with a portable hand tool marketed under the proprietary name of "Skilsaw"—in which a carborundum cutting wheel is driven at a high speed by a small electric motor mounted as an integral portion of the tool. A picture of the machine in operation is shown in Fig. 4. The experiment proved to be eminently successful; a longitudinal cutting rate of approximately 7 feet per hour was obtained, and the whole of the pipes were stripped by this method without the slightest damage to the cables.

The cables to be diverted contained a total number of 5,198 circuits, of which 2,274 passed through the

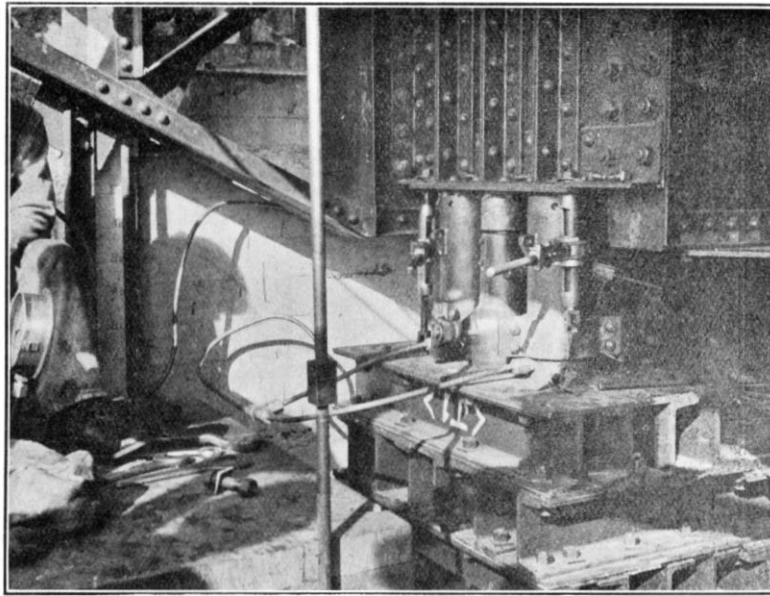

FIG. 6.—BANK OF HYDRAULIC LIFTING JACKS.

footway box on the west side, and 2,924 were contained in the cables on the east side of the temporary bridge. The pedestrian footway on the west side was closed to traffic by the bridge authorities, but the eastern elevated wooden footway was extended to pass over the box on the east side and so allow work in the footway box to proceed uninterrupted, and, by adjustment, to permit pedestrian traffic to continue

Raising of the Bridge Span.

On Thursday, October 15th, at 5.30 a.m., the work of lifting the 1,000 ton bridge span was commenced, and the operation was completed at 12 noon on October 16th. During this interval in which the span was being raised a roadway was constructed, rising from a point outside Somerset House to a height of 5 ft. 6 ins. at the point of connection with the new

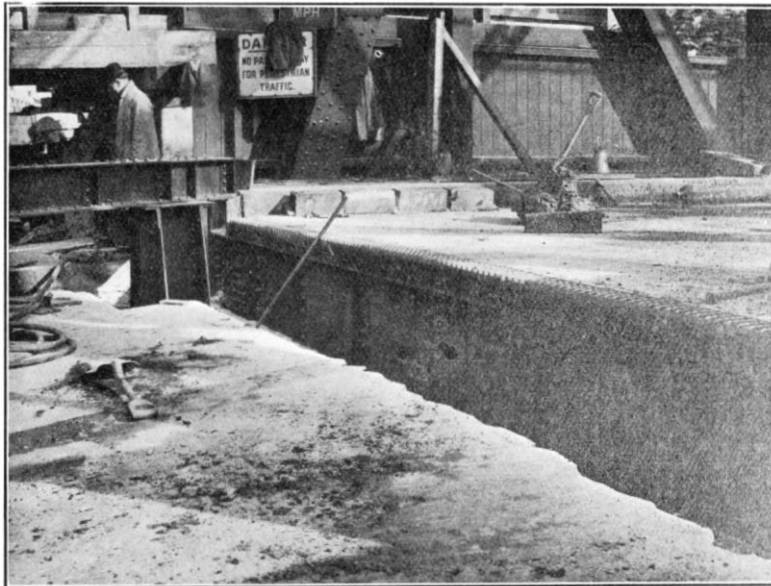

FIG. 7.—LEVEL OF BRIDGE SURFACE BEING RAISED.

unobstructed even during the actual raising of the bridge span.

The cables at the manhole at A were pieced out and placed round the walls; a photo of the completed joints is shown in Fig. 5.

In the boxes at E and F it was found possible to "balloon" the cables, and the circuits were then diverted by cutting and jointing direct to the new cables.

level of the raised span, and within the short space of four days, from the time of closing the bridge to traffic, the bridge engineers were again able to allow the normal passage of road traffic across the river.

As a matter of interest to readers, two photographs are given, showing (Fig. 6) a bank of hydraulic jacks employed at the north end and (Fig. 7) the bridge level being raised.

A Simple Transmission Measuring Equipment

L. E. RYALL, Ph.D. (Eng.), A.M.I.E.E.
and A. G. BURGESS, A.M.I.R.E.

A description is given of a constant output 1 mW oscillator, a simple direct reading transmission measuring set and a 1 mW calibration unit.

Introduction.

THE recent increases of trunk circuits, and particularly of minor trunks between zone and group centres incorporating unit amplifiers, have led to a demand for suitable testing equipment and particularly transmission measuring apparatus. This equipment must be as simple as possible to operate, and since large numbers are required it must be cheap. Also it must be capable of operation from all forms of power supply which will be encountered, and the accuracy of measurement must be practically independent of the fluctuations of the supply voltages. The performance of the apparatus which has been developed adequately meets these requirements and will no doubt have a considerable use in other fields in which precise attenuation measurements at audio frequencies are required.

The apparatus consists essentially of:—

- (1) a constant output oscillator ;
- and
- (2) a direct-reading transmission measuring set.

A milliwatt calibration unit for accurate adjustments is also described.

THE CONSTANT OUTPUT OSCILLATOR

The oscillator is of the 3-electrode valve type in which the anode is resistance coupled to the tuned grid circuit. The amplitude of the oscillation is limited by the flashing of a neon tube, so that a constant voltage signal is generated. This is fed to a number of independent outputs through resistors of 600 ohms impedance.

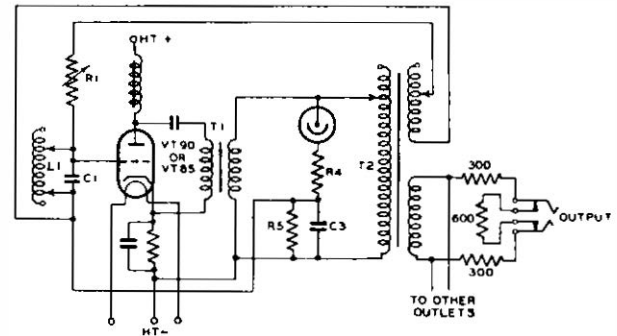

FIG. 1.—SIMPLIFIED CIRCUIT OF CONSTANT OUTPUT OSCILLATOR.

The circuit design of the oscillator is shown in Fig. 1 and one form of the instrument, rack mounted for repeater station use, is shown in Fig. 2. The valve anode circuit is choke-capacity coupled to a step-up transformer across the secondary winding of which is connected a specially aged neon lamp in series with resistors R4 R5 and the primary winding of the output transformer T2. The feed-back winding is connected via an adjustable resistor R1 to the resonant circuit L1, C1, tuned to the required oscillator frequency, and associated with the grid circuit of the valve. For repeater station use frequencies of 300, 500, 800, 1,400 and 2,000 c.p.s. are available. The tapped output winding is connected to 4 output jacks via 300 + 300 ohm resistors and the outputs are normally closed with 600 ohms. When set up the output is

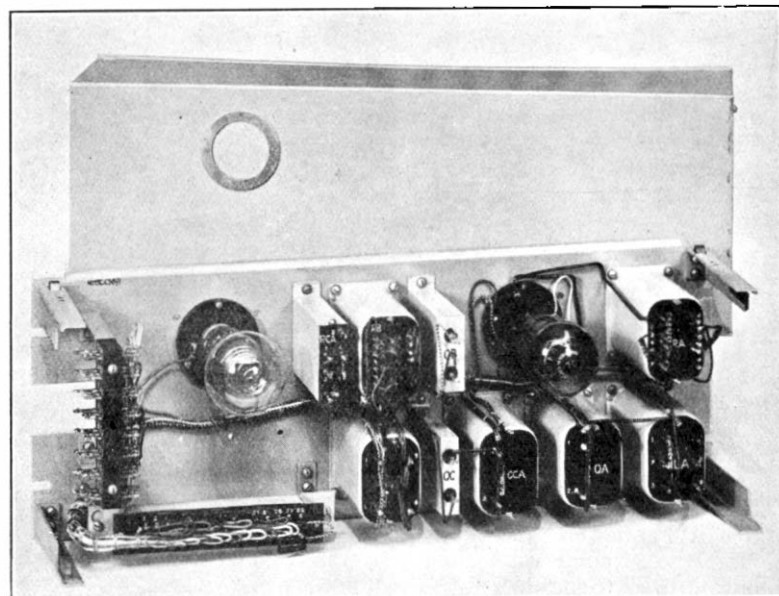

FIG. 2.—1 mW OSCILLATOR.

adjusted to 1 mW (± 0.07 db.) by means of the taps on the windings of the output transformer. Oscillation is obtained by reducing the value of the feed-back resistance to 1,000 ohms less than that required to produce oscillation with the tube flashed under adverse load conditions.

The Controlling Action of the Neon Tube.

The amplitude of the oscillation is limited to that which just flashes the neon tube. As soon as the tube flashes the limiting action prevents any further increase of the signal that is fed back to the grid circuit so that the oscillation does not tend to build up excessively. If there is no further controlling effect, the limiting action produces distortion of the wave form resulting in a total harmonic content about 23 db. below the fundamental frequency signal. A second controlling effect, however, is obtained by use of the property of the "Beehive" type neon tube that the flashing voltage when the plate is negative is less than when the "Beehive" is negative. The neon tube operates as a rectifier and the rectified voltage obtained across the resistor R5, filtered by condenser C3, is fed into the grid circuit of the valve to increase the negative grid-cathode bias voltage. The valve amplification is reduced, which causes a reduction in the limiting action of the neon tube and of the rectified voltage. Thus a state of equilibrium is set up in which the neon tube is only just flashed. Due to the non-linear characteristic of the valve, one-half wave of the oscillation has a slightly greater maximum amplitude than the other, and this half-wave is used to flash the neon tube by suitably arranging the transformer and lamp connections. By this means the amplitude of the oscillation is maintained constant and equal to that which just flashes the neon tube, but very little power is absorbed by the tube so that the harmonic distortion is small.

Performance Characteristics of the Oscillator.

The following performance characteristics apply when one to three outlets are either short-circuited or open-circuited, with supply variations up to $\pm 10\%$ from normal, and measurements are made on the fourth outlet.

Stability of Output Power. The change in output power from the "set up" value of 1 mW is less than 0.1 db., provided the temperature is constant, and

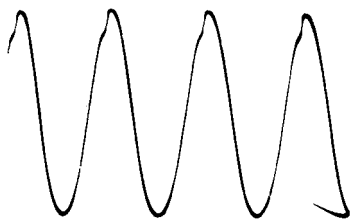

FIG. 3.—WAVE FORM OF 1 mW OSCILLATOR.

this degree of stability is maintained over a period of years.

Effect of Temperature Change on Stability of Output Power. With normal type neon tubes day to day temperature changes may produce a change in output of up to 0.15 db., other conditions being constant. With specially selected neon tubes this error can be

reduced to well below 0.1 db. for large temperature changes.

Frequency Stability. Under conditions given above the frequency change is less than 0.1%. With reactive loads ($Z_0 = 600 \angle 45^\circ$) the change is less than 0.25%.

Harmonic Content. A cathode-ray oscillogram of the wave form is shown in Fig. 3. The actual harmonic voltages given as percentages of the fundamental signal voltage are as follows:—

Harmonic	% of fundamental
2nd	1.6
3rd	1.4
4th	1.4
5th	1.3
6th	1.1
7th	1.1
8th	0.9
9th	0.8
10th	0.7
11th	0.6

Increased Outlets. The number of outlets can be increased up to 12, and the total maximum harmonic content is then approximately 5%. The other characteristics are practically unchanged.

Output Impedance. This is equal to the resistance in series with the output, i.e. 600 ohms. The constant voltage signal obtained across the windings of transformers T2 ensures that the transformer impedance is effectively zero.

Power Supplies

The oscillator operates with 16 V or 21 V, 0.25 amp. A.C. or D.C. supply (or 4 V, 1 amp using valve VT 90) and 150 V anode supply (12 mA). A mains unit shown in Fig. 4 will supply up to a maximum of 6 oscillators

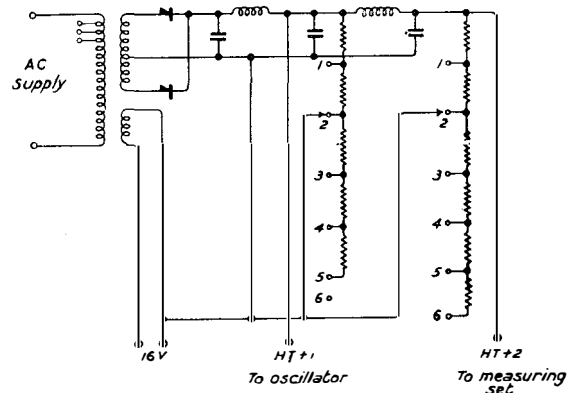

FIG. 4.—MAINS UNIT FOR 6 OSCILLATORS AND 6 TRANSMISSION MEASURING SETS.

and 6 measuring sets simultaneously. Artificial anode loads are used to maintain the anode voltage reasonably constant when less than 6 oscillators and 6 measuring sets are used.

Other Applications of the Oscillator Design.

The oscillator using the power supplies stated will provide any output directly from the transformer T2

up to 30 mW without the output voltage changing more than 1% and with a total harmonic content of less than 5%. If the load is non-reactive or reactive (45°) the frequency change is less than 0.3% and if the load is wholly reactive the frequency change is less than 1%. With the larger anode voltages, these output powers can be increased. The design is therefore very suitable for generating the carrier signals

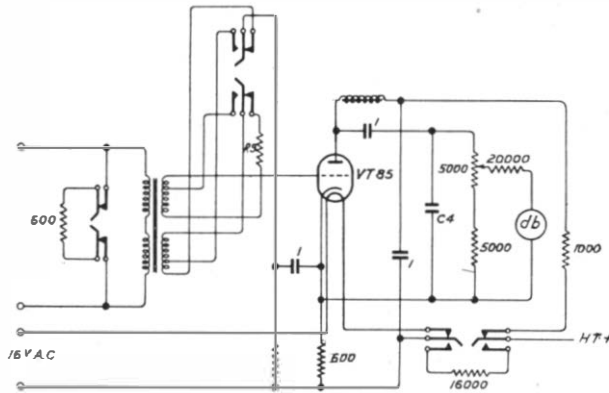

FIG. 5.—SIMPLIFIED CIRCUIT OF TRANSMISSION MEASURING SET.

for V.F. telegraph systems and all forms of A.C. signalling systems where the load conditions vary or constant output voltages are required.

The large number of independent outlets that can be obtained, with the absolute reliability of the constancy of output, make it invaluable for laboratory use where measurements at an audio frequency are made.

A 2 to 1 frequency range in which the output does not vary by more than 0.1 db. and the harmonic content is less than 5%, can be obtained with a suitable tuning inductance and merely varying the tuning condenser. With step-by-step inductance changes in conjunction with a variable tuning condenser a frequency range from 50 to 10,000 c.p.s. can be obtained with the same output characteristics.

A DIRECT READING TRANSMISSION MEASURING SET

The apparatus consists of a single stage valve amplifier, the output of which is applied to a rectifier voltmeter through a high resistance. A logarithmic scale is obtained by means of suitably shaped magnet pole-pieces. The circuit is shown in Fig. 5, the complete equipment suitable for rack mounting in Fig. 6 and the scale shape in Fig. 7.

The Meter Design.

The moving-coil meter consists of the most sensitive 3½-inch commercial instrument it is possible to obtain, consistent with accuracy and freedom from stickiness. The best

performance is obtained with the scale horizontal, although vertical mounting can be used. A Westinghouse rectifier combination is associated with the meter and the full-scale deflection is obtained with an A.C. input of 1 milliampere. Due to the associated rectifier the impedance varies from 1,000 ohms at full scale to 10,000 ohms at 30 db. below full scale. This impedance is affected by temperature changes and the reading of the meter can only be made independent of temperature by adding a swamping resistance of 20,000 ohms in series. This also ensures that the load applied to the amplifier is reasonably constant and independent of temperature. Hence the effective full scale input is 21 volts, 1 milliamp. A little consideration will show that it is not possible to obtain any degree of accuracy with a rectifier instrument intended to measure signals of telephone powers without an amplifier. Owing to the varying impedance of the instrument accurate reading can only be obtained if the input impedance is constant or very low compared with that of the instrument.

Calibration of the Meter and Meter Accuracy.

Since it is necessary to calibrate the meter in association with the 20,000 ohm series resistor it is best calibrated in conjunction with a sample amplifier of the type with which it will normally be used. The meter accuracy is as follows:—

From 0–20 db. the error is less than ± 0.25 db. at each db. calibration.

From –20 to –30 db. the error is less than ± 0.5 db. at each db. calibration.

The Amplifier Design.

The input signal is applied via a transformer (1 : 5 step-up ratio) to the grid circuit of an indirectly heated amplifying valve ($\mu = 12$, $Z = 3,000$ ohms). The anode circuit is choke capacitance coupled to the load resistance of 10,000 ohms. Grid bias potential is

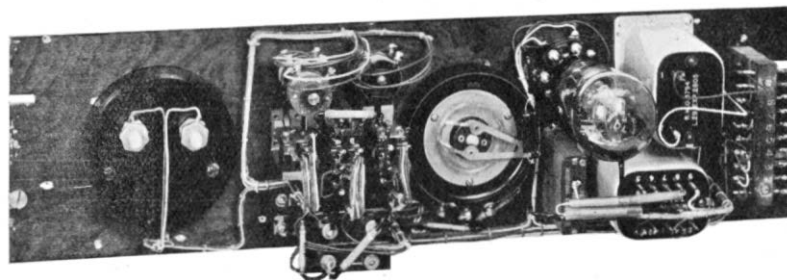
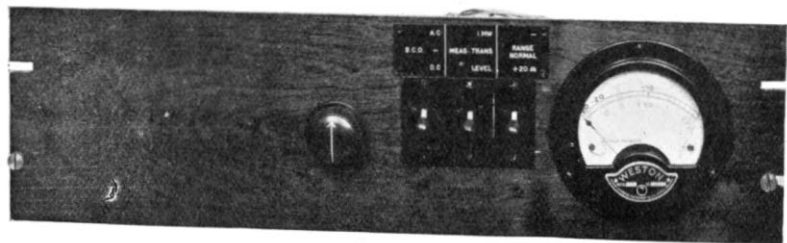

FIG. 6.—DIRECT READING TRANSMISSION MEASURING SET. FRONT AND BACK VIEWS.

obtained across a 600 ohm resistor in the cathode circuit and this, in combination with the high load impedance, ensures that the amplification is practically independent of supply voltage variations. The variations in amplification of different valves are taken up by the potentiometer. The input impedance of the amplifier is more than 10,000 ohms over the range 200

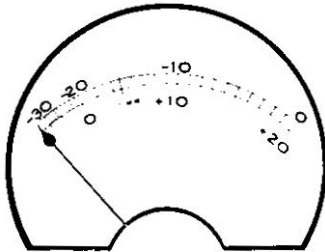

FIG. 7.—SCALE SHAPE OF TRANSMISSION MEASURING SET.

to 3,000 c.p.s. and more than 2,500 ohms over the range 50 to 10,000 c.p.s. The input can also be closed with 600 ohms. A 20 db. tap is provided on the secondary winding of the input transformer so that the range of the meter, which is normally 0 db. to -30 db. referred to 1 mW, can be increased to cover the range +20 db. to -10 db.

The Performance of the Complete Instrument.

Battery variations. The amplifier is intended to operate with an anode battery of 130 volts and a heater battery of 21 volts or 16 volts, 0.25 amps or 4 volts, 1 amp. When operated from the mains power panel the maximum change in the meter reading is 0.1 db. for $\pm 10\%$ supply voltage variation and 0.2 db. for $\pm 15\%$ supply voltage variation.

Valve variations. A 40% change in valve impedance produces a maximum error of 0.1 db., while with an 80% change the error is 0.2 db.

Frequency range. The errors normally present at frequencies above 3,000 c.p.s. due to the amplifier design and the rectifier in association with the meter are corrected by means of resistor R9 and condenser C4. The error over the frequency range 300 to 3,000 c.p.s. is less than 0.15 db. as compared with the 800 c.p.s. value, and does not exceed 0.25 db. between 120 and 10,000 c.p.s.

Input impedance. Over the range 200 to 3,000 c.p.s. the input impedance is such that in making level measurements on circuits of 600 ohms, the error is less than 0.1 db.

Temperature error. The maximum error at any point on the scale is less than 0.25 db. over a temperature range of 20° to 40°C. If, however, any error at full scale, which can be checked by means of a 1 mW signal from a 1 mW oscillator, is corrected by means of the potentiometer, the temperature range can be increased from 0° to 50°C without the error exceeding 0.25 db.

To Set up the Instrument.

An input of 1 mW at a frequency between 300 and 2,000 c.p.s. (which can usually be obtained from a "1 mW" oscillator) is applied to the input terminals (closed 600 ohms) and the potentiometer adjusted

so that the needle reads zero. The set is then ready for use. If no previously calibrated signal source is available the meter itself in series with a resistor of approximately 5,000 ohms can be used to measure a signal of 1 mW from an oscillator. The accuracy of this calibration however, is affected by temperature and should not be used if a more reliable method is available such as the 1 mW oscillator or the 1 mW calibration unit about to be described.

A 1 mW CALIBRATION UNIT

The calibration unit shown in Figs. 8 and 9 is designed to give an accurate means of calibrating 1 mW of power from a generator of internal impedance 600 ohms into a resistive load of 600 ohms. The supply to

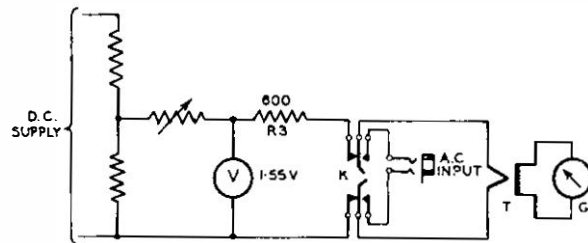

FIG. 8.—CIRCUIT OF 1 mW CALIBRATION UNIT.

the meter is adjusted to be 1.55 V. This voltage is in series with a resistor R3 of 600 ohms and with one position of the key K it is supplied to the thermocouple T and galvanometer G. With the key in another position the output voltage of the 600 ohm generator is supplied to the thermocouple and galvanometer. When the galvanometer readings under the two conditions are the same it follows that an E.M.F. of 1.55 volts is being developed in the 600 ohm output circuit of the generator under test. This is the condition required to give an output power of 1 mW

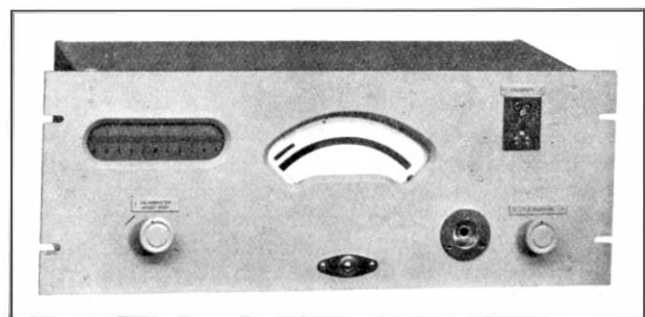

FIG. 9.—1 mW CALIBRATION UNIT.

into a load of 600 ohms and is independent of the resistance of the thermocouple. With commercial tolerances on the accuracies of the voltmeter V and the resistor R3 the calibration of the A.C. source is accurate to within ± 0.1 db., the internal impedance of the source being assumed to be 600 ohms exactly.

With the key central the A.C. input is applied via a Westinghouse rectifier to the D.C. voltmeter (connections not shown in Fig. 8). Provided the deflection obtained is less than 0.3 V (shown red on the instrument) the thermocouple will not be overloaded by the signal.

The Maintenance Aspect of Overhead Construction Work

R. C. C. BROWN

The author reviews the relationship between methods of construction and fault incidence. An examination reveals that departures from standard methods of construction, due often to a desire to ensure speedy completion of work, often result in poor construction and a high fault incidence.

Introduction.

RECENTLY, under the ægis of the External Plant and Protection Branch of the Engineer-in-Chief's Office, an examination has been undertaken of the standard methods of construction of overhead line plant in their relation to the fault liability of the plant. Maintenance and construction works in progress have been observed, in an endeavour to ascertain to what extent, if at all, standard methods fall short of the practical requirements in the field, and it is proposed to deal with the conclusions arising from such observations.

With economic considerations playing such an important and necessary part in the Department's programme, care must be taken that maintenance standards are not lowered. Speedy completion of the work necessary to connect a new subscriber (advice note work) must remain an essential, but it is of primary importance that the benefits of this are not nullified by the indifference, through faults, of the standard of service provided.

No article of this nature could be complete without some reference to organisation difficulties and the demands of the system. Shortage of skilled staff, the lag in the provision of local underground plant and the urge to complete advice note work quickly contribute largely to the present fault position. Plant and staff deficiencies will, however, diminish with the increase of development work now in hand and the comprehensive training provided for new entrants to the Engineering Department, while the requirements of speedy advice note completion, consistent with a higher standard of construction, can be attained, to some extent, by improved organisation and closer co-ordination between the maintenance and construction groups.

Standard Methods of Construction.

The maintenance procedure as set out in the Department's Engineering Instructions appears to cover all contingencies, and, while the functions of fault controls are outside the scope of this article, it is of importance to record that the machinery is available for the improvement of the fault position. Periodic inspections, annual renewals and the normal procedure for the authorisation of outstanding maintenance work make provision for the remedying of all plant defects. Only by this means can be avoided the vicious circle of increase of faults, more staff engaged on faulting, fewer staff available for maintenance work and a consequent further increase of faults.

The "Engineering Instructions" relating to standard methods and design are reasonably comprehensive and no serious modification appears necessary. Departures from standard, prevalent in practice, arise mainly from the desire to ensure speedier completions of work, but no evidence exists that improved construction has resulted. Recent changes of design appear satisfactory under the restricted conditions

prescribed for their use, but their extended use under any conditions provides a serious fault factor. Covered drop wire and extension brackets are typical examples of new design which are frequently used with some lack of discretion. Fault incidence has, thereby, increased with the consequent tendency to condemn such changes in practice. Misleading conclusions will arise if information as to shortcomings of plant is based on misuse, and the importance of the adoption of standard methods cannot be too strongly emphasised.

Strengthening of Lines.

Analyses reveal that more faults are due to defective regulation than to any other cause and that line instability is a serious contributing factor. Many remedial measures are possible under current advice note works. Strengthening of lines to the permissible maximum of four poles per advice note, with the addition of stays at angles, would quickly effect improvement and would not seriously retard the advice note programme. Works outside the scope of the advice note could be covered by estimates and could frequently be completed in conjunction with advice note works.

The strengthening of a line is often deferred because of the suggested imminent provision of underground cables, though too often, in these days of pressure, that is the excuse rather than the reason for deferment. But even where development studies are contemplated delays of two or three years are possible before the new cables are available, during which period further wires are added, usually on extension brackets without the additional support of arm braces, until good regulation becomes an impossibility. Where the history of a line is available it is interesting to observe the increase in fault liability of the existing wires as new circuits are added and examination will often reveal that little or no strengthening has been done.

Wayleave difficulties sometimes preclude the provision of stays or permit stays only of inadequate spread. When positions for struts are not available added stability can be provided by the use of poles of heavier class.

The Regulation of Wires.

There is a serious danger in departing from pre-war standards, when, regardless of the number of wires, one vice per terminating point was considered essential for good regulation. Because of the saving of time that is effected, hand regulation has become very prevalent and contributes in some measure to regulation difficulties. This method provides no means of tensioning the wires equally, seeing that one wire must be made off before a second wire can be strained, which operation affects the tensioning of the first wire. Hand regulation, too, leads to damage to the surface of the wire due to the use of pliers for tensioning, while, to hold the strain while the termination is being made, additional turns are taken around

the insulator, leading to further possible damage.

It is argued by some workmen that experience teaches the correct tensioning of wires and that no theoretical application is necessary ; some regulate by the feel of the wires, other tie themselves to a fixed reading on the tension ratchet. Tension tests, which have been made on some completed works, reveal that correct regulation is arrived at only by accident, little regard being paid to temperature variations.

Practical considerations have restricted the spacing between wires, consequently the dip is limited. Wires must be so tight that the risk of contacts is eliminated, yet sufficiently slack to permit of a considerable increase of tension due to fall of temperature and storms. Provision must be made for the increase of tension produced by the horizontal pressure of winds and the greater vertical loads due to the accumulation of snow and ice. The prescribed tensions take into account the foregoing factors and also provide a suitable factor of safety in respect of the breaking weight of the wire. With so many considerations involved it is impossible to develop a sixth sense in this respect. Recourse to standard methods and the use of regulation tables are the only safe means of regulation.

New wires are frequently erected on lines where existing wires are already in bad regulation. In the absence of any provision for the re-regulating of existing wires there is no alternative but to conform to the same defective regulation with the new wires and faults will result. The urgency of completion of an advice note work will not always permit of the execution of the necessary maintenance work, though frequently in this respect more profitable use could be made of gangs. When the re-regulating is of such magnitude as to preclude of the possibility of its completion in conjunction with the advice note, advantage should be taken of the "outstanding maintenance works" procedure.

The Use of Sleeves.

Hand regulation is made possible by the wrapped bight termination, which is still largely used although the sleeve method of terminating is the standard method. Wrapped bight terminations have the disadvantage that they afford facilities for hand regulating and for "unpicking" and re-use of the old termination during the re-regulating of wires. There is no evidence that these disadvantages can be offset by other considerations, as, in a recent examination of broken terminations, the wrapped bight was found to predominate. Breakages, probably due to corrosion, had taken place inside the wrappings and, where the free end of wire had broken, considerable difficulty was experienced in locating the fault. It is admitted, however, that it is difficult to get conclusive comparison between the two terminations since no information is available of the number of each type of termination in use.

Breakages at sleeve terminations occur most frequently on the free end of wire at its point of entry into the sleeve. This defect will, in a large measure, be remedied if the free end of wire, on leaving the sleeve, is taken in an easy sweep to the insulator instead of being bent at right angles to the line wire. There is some evidence that such breakages at the sleeve are due to vibration and a method of holding the free end rigid may need to be introduced.

It is sometimes contended that the use of sleeves introduces an abnormal fault liability, but analyses reveal that wire breakages are comparatively few under normal conditions. Greater care and conformity to standards are essential in the use of sleeves. The correct number of twists should be inserted, black paint should invariably be used to seal the ends against the entry of moisture, and the use of pliers in lieu of jointing clamps should be discontinued.

The Use of J Wire (wire covered with an impregnated cotton braiding) to reduce Faults due to Game.

Numerous faults are caused by game flying into wires, and though inspection revealed that frequently defective regulation was a contributory cause, there is no doubt that, in many instances, game guards are ineffective, especially against a background of trees. It is suggested that the difficulty might be overcome by the use of J wire throughout where the number of wires is small, and where too many wires exist for the use throughout of J wire, it might be used on the outer positions of the arms.

Leads on Distribution Poles.

Mechanical and other damage to leads on distribution poles is generally attributable to the untidy condition of such leads and, in the main, it does not appear that the system of cleating or the type of cleat is at fault. The tracing of leads, on a congested pole, is a frequent cause of untidiness, leads being pulled from position and not restored. The most prevalent cause of disarray, however, is considered to be due to cable pair alterations on the block terminal, to meet line changes or to clear faults. Leads terminated at the bottom of the block are re-connected to terminals at the top and the necessary slack is obtained by removing the leads from their cleated positions on the pole and arms.

Fault Incidence and Methods of Construction.

Faults due to trees preclude the possibility of a decline in overhead faults during the comparatively fine weather of the summer months. Considerable improvement can be effected, however, by adequate lopping and the provision of good clearances during the erection of new lines. Comprehensive instructions have recently been issued in connection with tree-cutting and there is no necessity to treat the matter in detail in this article.

Many other instances are available to demonstrate the close relation between construction work and the fault incidence of plant. Faults on last spans to subscribers, not wholly due to the quarter-twist and horizontal formations but frequently caused by the unequal tension of wires due to hand regulation ; unsatisfactory layout of plant ; irregular methods of leading-in, all contribute their quota to the growing incidence of faults. The excuse is sometimes made that mass production methods in telephone construction must lead to a general lowering of standards of work. Output is, however, of prime importance in every industry, yet there is no general evidence elsewhere that quality is sacrificed for quantity. Standard methods define the quickest possible operations consistent with a high standard of work and relative immunity from faults, and departure from recognised procedure usually results in unsatisfactory conditions.

Centralised Routiner and Maintenance Control in Automatic Exchanges

A. E. BROGDEN

A description is given of a system of centralised routiner and maintenance control which has been installed on an experimental basis at Whitehall Exchange, London, and its results are discussed.

Introduction

IN small automatic exchanges routine tests are performed by means of manual testers which are portable and have to be connected by plugs and cords to jacks on the equipment to be tested. The various tests are applied, one at a time, by means of keys operated by the testing officer.

In large automatic exchanges, routine tests are performed by automatic routers which consist of testing apparatus assembled on a rack. Permanent cable and access selectors are provided to connect the routiner with each group of apparatus to be tested. When the routiner "start" key is operated each item is routine-tested individually, all the functions of one item being tested automatically before passing on to the next. Each routiner is

points throughout the exchange the circumstances are not the best from a supervision point of view.

The system of centralised routiner and maintenance control which has recently been introduced at Whitehall exchange, London, sets out to remedy this defect. New features which constitute a departure from standard practice have been incorporated, and for this reason a description of the scheme may prove to be of general interest.

Control Equipment.

The key and lamp display panels of each of the 15 routers have been duplicated on centralised positions installed in a small room adjacent to one of the automatic switchrooms. Circuits used for reporting exchange faults, both by day and night,

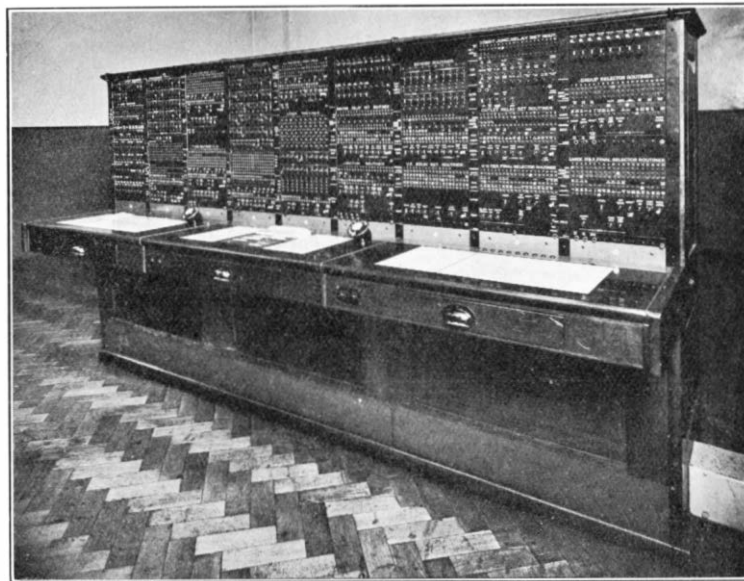

FIG. 1.—VIEW OF THE CENTRALISED POSITIONS.

equipped with a key and display panel which provide for subsidiary features and give lamp indication of the particular item under test and the particular test in progress.

The normal arrangement is to allot a particular section of the exchange equipment to an apparatus faultsman who controls the automatic routers and attends to all faults arising in that section. After satisfying himself, by the application of the routiner, that a fault has been removed in a satisfactory manner, the relevant fault docket is completed and returned to the fault record officer.

The nature of each fault and the result of the investigation do not come to the personal knowledge of the responsible senior officer as a matter of course, and as the automatic routers are situated at various

have also been extended to an incoming panel of the desk. The addition of signalling and speaking circuits between the desk positions and each routiner completed the arrangements necessary to permit of the control of routine testing and fault clearance from the central point known as the control room.

Essentially the principle consists of the distribution of exchange faults by a controlling officer who retests the equipment before it is restored to service in much the same way as is done by test clerks in the case of external faults.

Fig. 1 is a view of the centralised positions which consist of three test desk units installed side by side providing nine panels. The duplicate control keys and indicating lamps of the 15 routers in this 10,000 line exchange are distributed over eight panels, each

panel catering for one or more routiners according to the space required by the duplicate equipment. Fault reporting and intercommunication circuits are concentrated on the ninth panel, known as the

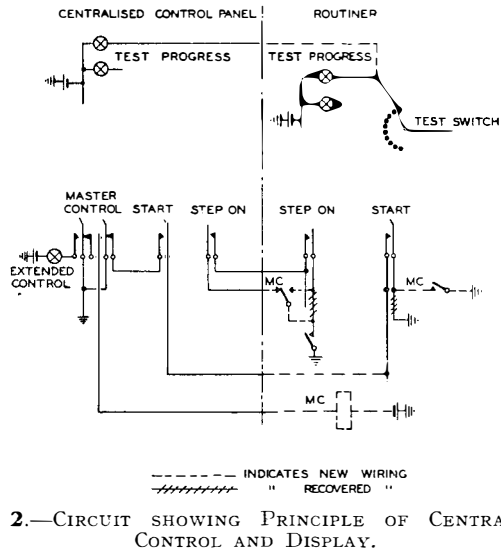

FIG. 2.—CIRCUIT SHOWING PRINCIPLE OF CENTRALISED CONTROL AND DISPLAY.

“telephone panel,” which is shown on the extreme left.

Details of the equipment installed on the panels are as follows:—

(1) *On Routiner Panels*

Duplicate control keys and indicating lamps for each routiner.

A master control key for each routiner.

(2) *On Telephone Panel*

Keys and lamps to provide facilities for communication between two head set telephones and (a) each automatic routiner, (b) each fault reporting circuit.

Alarm apparatus.

On the face equipment green opals and black labels with white engravings have been fitted in order to reduce eye strain to a minimum. All connections are made by means of keys which permit of greater speed and are subject to a lower fault liability than plugs and cords.

One to six additional relays for control purposes were required on each routiner according to the number of controls to be intercepted.

Facilities and Circuits

All general routines are conducted from the control room, and it is essential that their progress shall not be interrupted in any way by the manipulation of the keys on the routiners. As will be seen from the diagram in Fig. 2 the keys installed on the routiner are rendered ineffective and their

functions transferred to the control room by the normal contacts of the master relays. When it is necessary to extend control to the routiners, as when clearing faults which entail adjustments, the master key in the control room is thrown, operating the master relays. By this single key-operation local control is restored and interruption prevented should the control room routiner keys be left thrown or accidentally operated during the progress of tests.

Fig. 3 shows typical connections to the telephone panel. Circuits which provide bothway auto call and clear conditions in addition to speaking facilities are provided between each routiner and either control room position circuit. Individual 3-wire circuits are employed, the third wire being utilised for signal purposes.

In addition to the special fault circuits the following have been extended to the control positions for fault control purposes:—

Bothway circuit to the test desk junction test position.

Extension line on service P.B.X.

Extension line on service P.A.B.X.

Night service ENG.

Night service teleprinter.

Alarms

Routiner alarms, both “prompt” and deferred,” normally appear in the control room, which is treated as an exchange sub-section, but may be restored to the routiner sub-section at the discretion of the control officer. The night service fault reporting circuits are extended to an exchange alarm sub-section via a “night switching key” during periods when the control room is not staffed.

General Maintenance Arrangements

Routine testing and the clearance of all exchange plant faults, routine and non-routine, are under the control of a skilled workman class 1 (S.W.1) who is

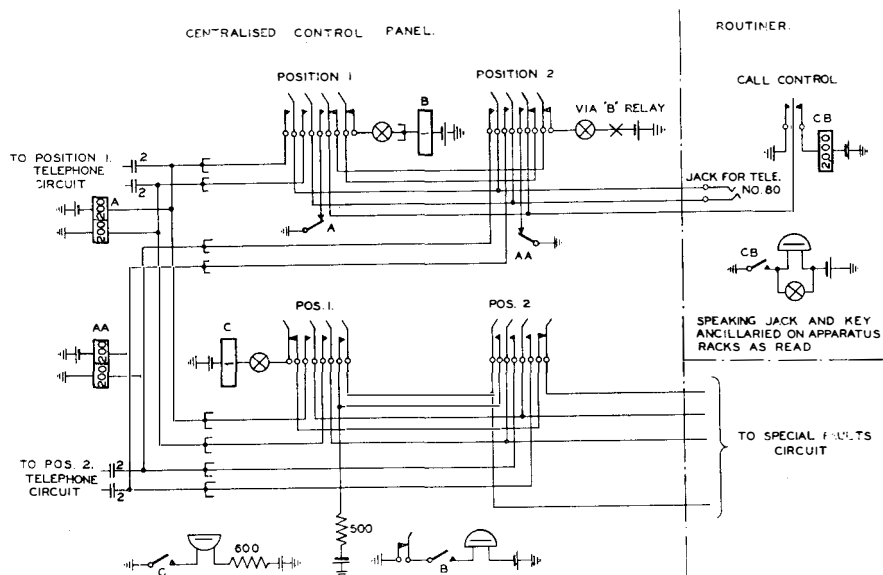

FIG. 3.—TYPICAL SPEAKING AND SIGNALLING CIRCUITS BETWEEN CONTROL POSITIONS AND (A) ROUTINERS, (B) FAULT REPORTING CIRCUITS.

located at the telephone panel in the control room. This officer prepares dockets for all faults reported, maintains special faults records, passes details of faults to, and receives details of clears from, the maintenance staff. An assistant controls all routine tests, prepares dockets for all routine faults and passes them to the S.W.I. for distribution.

Particulars of the fault are immediately passed over the fault control circuit associated with the routiner to the maintenance officer appointed to that section of plant. He deals with the fault in the usual manner, local control of the routiner being restored when necessary, and phones particulars of the clearance back to the control officer. Responsibility for the expeditious "busing" and subsequent removal of faults rests with the control officer, who confirms that faults have been removed by carrying out a "retest" before the docket is passed to the fault record officer for completion of the standard fault records.

It will be seen that the standard fault procedure is not departed from except that all exchange fault reports circulate via the control officer. The detailed procedure which has been adopted for the treatment of various classes of "calls held" and faults works smoothly.

Between the hours of 8 p.m. and 8 a.m. the night service ENG. and teleprinter fault circuits are extended to the control room and switched to an exchange sub-section "prompt" alarm. The S.W.I. on night duty deals with complaints and faults in the normal manner and prepares and completes dockets which are deposited in a special compartment in the control room.

Time lost due to "busy" conditions makes routine testing of certain ranks of equipment impossible during normal hours of duty. The performance of these routines by the S.W.I. on night duty is greatly facilitated by the use of "Centralised Control."

Advantages of Centralised Control

Under centralised routiner and maintenance control a far greater measure of supervision of fault clearance is exercised. The control S.W.I. is personally dealing with every fault and ensures that it is satisfactorily cleared with the least delay. His experience is available to assist the staff in the clearance of faults and he is in an excellent position to co-ordinate the investigation of any faults where attention to various parts of the plant must be given by different maintenance men. He can readily test the apparatus after the clearance of faults, thus checking the quality of maintenance work and in this respect the circumstances are ideal. He is able to recommend special attention to portions of the equipment for the purpose of anticipating faults and also to recommend changes in the testing frequencies as a result of experience gained in operating the rouniners.

The advantage of an organisation which enables one officer to be in close touch with the fault position on all sections of the exchange plant is apparent. Any general failure of the exchange plant quickly becomes obvious to him and an abnormally high

fault liability on a portion of the equipment is readily detected. In short, satisfactory performance of the exchange equipment is checked by "keeping a finger on the pulse."

As the preparation of dockets is confined to a small number of men, there is greater uniformity of practice and consequently records are more accurate.

In estimating the advantages to be gained the increased fault liability due to the introduction of additional relay contacts in the rouniners must not be overlooked. With a view to reducing this liability to a minimum it is proposed to employ standard 3,000 type relays in future schemes.

Conclusion

Comparison of average fault returns for corresponding six weekly periods before and after the introduction of the scheme shows that, whereas the faults detected by rouniners had increased, total routine faults and total exchange faults had decreased. From this it may be assumed that the rouniners are being used to better purpose, and that in consequence of this increased efficiency the question of reducing the frequency of overhauls and inspections of apparatus could be considered with advantage. Such a decrease would reduce the amount of time spent on work which is of a monotonous nature and therefore liable to be inefficiently performed.

Although the scheme is most suitable for large director exchanges in which all items of plant are automatically routined, the advantages to be gained from centralised control may justify the installation of rouniners in smaller exchanges for which they would not normally be provided. In this connection the load carried by the control room staff is of interest. In addition to controlling routine tests, performing "retests," etc., approximately 600 exchange faults per week—i.e. an average of one every 10 minutes—are dealt with by the two officers.

In smaller exchanges a larger proportion of routine testing is performed manually, and difficulty would no doubt be experienced in allotting a full load to the control officer on account of the inflexible nature of the duty.

Although there has been no marked effect on written complaints or service observation returns, it is felt that more efficient supervision of the maintenance staff has maintained a higher standard of service, although differences in fault recording methods has rendered any reliable comparison somewhat difficult. Nevertheless the results of the experiment are sufficiently promising to justify an extension of the scheme to another suitable exchange so as to enable a decision to be reached regarding its adoption as standard. It has been decided, therefore, to proceed with the scheme at Temple Bar exchange, London, where special precautions will be taken to ensure that a true comparison of both cost and fault results can subsequently be made.

The construction work, including the installation of the desk, local distribution frame, cables and routiner modifications, was carried out by the London Engineering District.

Young People's Telephone Exhibition

E. C. BAKER

The author describes the main features of the second telephone exhibition for young people held at the Imperial Institute, London.

Introduction.

AFTER five years of exhibitions throughout the country a return was made to the Imperial Institute, South Kensington, the site where the Post Office publicity campaign first came into prominence with a telephone exhibition for young people in January, 1932, for the second Young People's Telephone Exhibition which commenced on the 14th December, 1936 and continued till the 16th January, 1937. Naturally those who remembered the pioneer show were interested to see how far the Post Office's exhibition technique had been developed during the succeeding five years. Two points impressed them almost immediately. The first, that excellent though the 1932 Exhibition had been it had not been planned with such an economy of display, nor had it possessed such high polish and glamour. The second, that telecommunications did not dominate the show, in spite of the fact that the original title of the exhibition had been retained. Most of the activities of the Post Office were represented in some way or other.

Cinema.

The Post Office Film Unit, which was set up on the 1st October, 1933, contributed an integral part of the scheme. Films produced by the Unit, illustrating Post Office activities, were shown in the theatre adjoining the main hall. After each programme there was an impressive demonstration, on the stage, of the Research Branch's 250,000 volt impulse generator. The cinema show was seen by 50,000 visitors during the course of the Exhibition.

Main Hall.

The Film Unit was also responsible for the modern decoration, in cut-out photographs, above the model cable chamber which occupied one end of the hall (Fig. 1); at the other end was the Research display. Along one side of the hall was a set of demonstration automatic telephone switches with a painted background of exchange scenes and two models of telegraph offices, Kensington and N.E. Ware

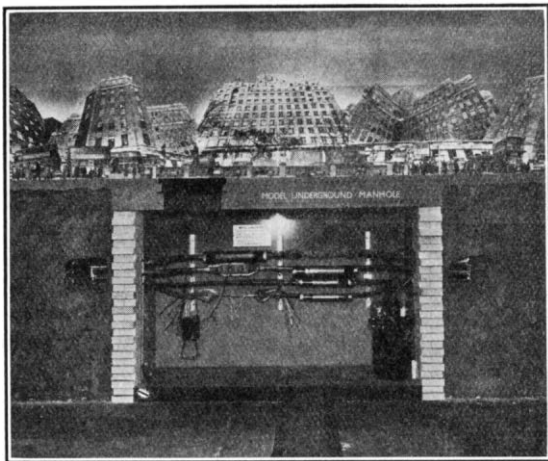

FIG. 1.—MODEL CABLE CHAMBER.

(Anywhere). 40,000 souvenir telegrams were sent by teleprinter between these two offices during the course of the Exhibition. The opposite side of the hall was occupied by dioramas illustrating Post Office uniforms



FIG. 2.—CABLE CHRISTMAS TREE.

from 1700 to the present day and depicting the loading of mails at the London Docks and at Croydon Airport. Between these dioramas were Air Mail and Imperial and Foreign Mail exhibits.

The now well known telephone cable Christmas tree (Fig. 2), festooned with coloured electric lamps, occupied the centre of the hall with a stand on each side. One of these island stands displayed a Private Branch Exchange from which the children were able to speak by telephone from one point to another in the Exhibition and also to ring TIM; the speaking clock was dialled about 11,000 times. A press button machine which displayed information about the Post Office Savings Bank also occupied a part of this stand. The second island stand showed a stamp cancelling machine in operation, a comprehensive exhibit of the Cable Ships, and working teleprinter and ABC telegraph instruments.

Behind the cable manhole was a realistic model of the Post Office underground railway (Fig. 3), and an actual train was on view.

Research Branch's Display.

At the opposite end of the hall was the Research Branch's display (Fig. 4). Above this were four posters recently designed by Mr. Eric Frazer. A

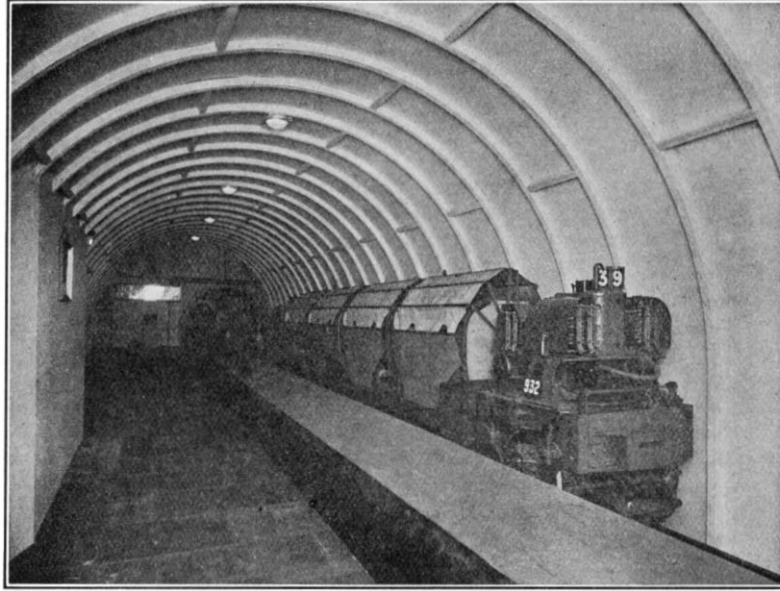

FIG. 3.—MODEL OF POST OFFICE UNDERGROUND RAILWAY.

Chinese navigator is shown setting his ship's course with the aid of a lode stone, then Wheatstone with his transmitter, then Dr. Watson registering intense surprise as he hears Professor Bell's voice in his telephone receiver (a painfully solid brick wall separates them), and, finally, Hertz experimenting with his wireless transmitter. On the Research stand was a Transmission Quality demonstration set consisting of two short lengths of cable in which there

the line conditions being simulated by arrangements of wave filters. A Voice-Delay apparatus was also demonstrated, in which speech from an ordinary telephone transmitter was amplified and the output current used to impart varying magnetic intensities to a continuous steel tape which could be revolved at varying speeds. These impressions were detected after the steel tape had travelled a short distance and were re-amplified and reproduced on a loud



FIG. 4.—VIEW OF MAIN HALL.

were music transmission pairs and ordinary pairs respectively. By means of clips it was possible to insert either normal line conditions or screened conductor conditions between the radio-gramophone with its special high fidelity loud speaker, and a cathode ray oscillograph could be switched into circuit to illustrate wide band or narrow band reproduction. This demonstration advertised the service given to the radio public by the Post Office,

speaker. At a further stage in the movement of the tape it passed through an intense alternating field which dispelled the impressed magnetism and allowed the tape to be used for the next transmission. The results of driving the tape at various speeds caused considerable amusement among the children.

Mails Exhibit.

The Imperial and Foreign Mails exhibit showed



FIG. 5.—AIR MAIL EXHIBIT.

the mail routes on a large world-map on which various towns were connected electrically to a keyboard of press-buttons representing the towns. When the button was depressed a light appeared on the map against the town represented by the button; this display proved a very popular test of geographical knowledge. The Air Mail exhibit was in the form of a map (Fig. 5) with associated keyboards where, by pressing the appropriate button, visitors were able

to the modern air liner Heracles; with an interjected scene of Gladstone speaking in 1861. 17,000 copies of this frieze, attractively printed in folder form with red covers, were presented to visitors.

Along one side of the Art Gallery above the main hall a working scale model of the "Up Special" night mail train was displayed (Fig. 6). The Gallery was converted into a realistic imitation of a railway station and a huge photograph of the railroad exit from

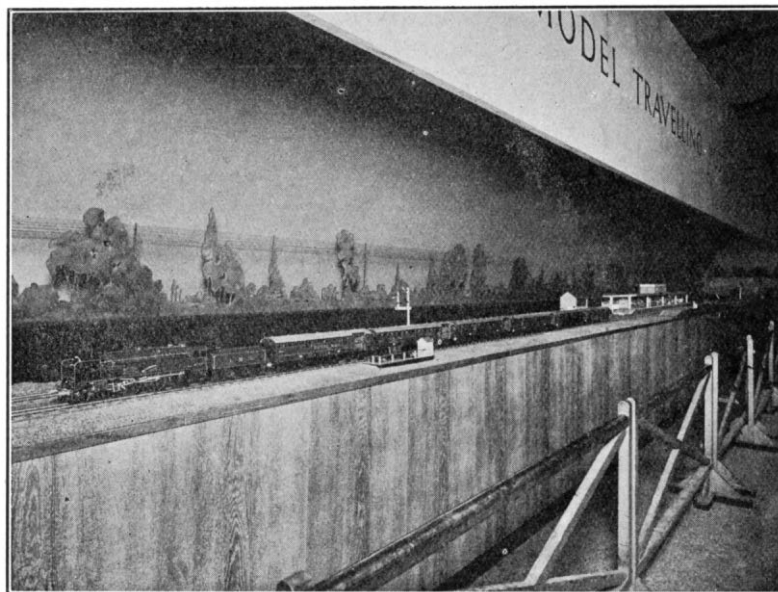

FIG. 6.—WORKING MODEL OF THE NIGHT MAIL TRAIN.

to see at a glance the illuminated route of the Air Mail and the saving of time effected in the conveyance of a letter by air to the selected town.

Along each side of the hall was a large illuminated silhouette frieze depicting the progress of message transmission from the time of the immortal Pheidippides, who covered the 150 miles from Athens to Sparta in two days in summoning help for the Athenians after the capture of Eritrea by the Persians,

a London terminus filled the far end. Opposite the model train was a full sized photographic representation of the Travelling Post Office (Fig. 7). The model train passed around the 200 foot track 4,000 times during the Exhibition. The electric motor of its engine thus revolved 27 times, and it is not surprising that when the Exhibition closed the bearings were showing signs of wear. There were 35,000 visitors to this gallery.

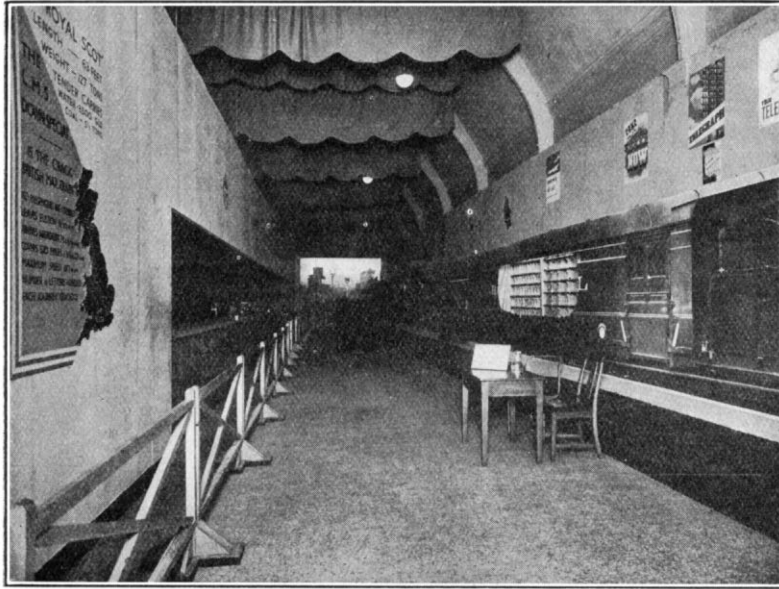

FIG. 7.—TRAVELLING POST OFFICE EXHIBIT.

Power Supplies.

Electricity for power and lighting was supplied from the University generating station; the total loads for the Exhibition were 46 kW for lighting and 7.5 kW for power, and 24,000 units were consumed. Eight miles of wire were used for the power and lighting circuits and $\frac{3}{4}$ mile for telephones and amplifiers.

●*Opening.*

The exhibition was opened on December 14th by Lord Iliffe, in the presence of Lord Snell, Chairman of the London County Council, and other distinguished visitors. The London County Council co-operated in arranging for conducted parties of school children, and 150 of these parties visited the exhibition.

General.

There was the usual crop of lost articles, and at the end of the Exhibition an unclaimed residue remained of 23 school caps, 17 odd gloves, 7 pairs of gloves, 9 belts and sundry scarves, lunches, etc. A number of the children adopted ingenious methods of avoiding the loss of articles or smaller children for whom they were responsible. One small girl, who was a frequent visitor, always had a younger sister attached to her by a length of string. One day a tiny girl was secured, after the fashion of Andromeda, by a barrier cord to one of the pillars. Her piercing wails brought members of the Exhibition staff post haste to her rescue.

A look-out was kept for the young genius who was in constant attendance at the 1932 Exhibition and who became known as "the boy who knows everything," but he did not visit this second exhibition; one hopes, of course, that all is well with him. A worthy successor to him appeared in a lad who spent most of his time each day of the Exhibition at the

Research counter, and told the staff there that he intended to join them as soon as he was old enough. He got to know all the members of the staff by name and, for relaxation, used to go to the Souvenir Telegraph Office and send telegrams to them.

The Exhibition wound up with a social evening at which all the Exhibition staff were present, and they took that opportunity to make a presentation to Mr. W. J. Bentlett, who was leaving exhibition work after four years as Engineer - in - Charge of Post Office exhibitions. Mr. Bentlett had used his abilities to great effect on this work, and there is no doubt that he can be accounted as largely responsible for the high standard which has now been reached in exhibition technique, and speakers at the presentation emphasised, too, the high regard which he had won for himself from every member of the Exhibition staff.

Conclusion.

The daily crowds of children, often accompanied by their parents, bore witness to the popularity of the Exhibition (Fig. 8). Such a show may not give immediate returns by an increase in telephone subscribers. It creates, however, in both the older and younger generations the feeling that the G.P.O.



FIG. 8.—GENERAL VIEW OF EXHIBITION.

is not a soulless Government Department but a live force whose staff are very human, keen on their job, anxious to provide facilities required by the public and desirous that the facilities already provided should be known to the public. The good relations established in this type of exhibition will bear fruit since to-day's schoolchildren are the Post Office customers of to-morrow.

A Route Distance Recorder

R. O. BOOCOCK, B.Sc. (Eng.)
and W. E. T. ANDREWS

This article describes a method of the accurate route measurement and spacing of loading points by means of a distance recorder driven from the sidecar wheel of a motor-cycle combination.

Introduction.

THE heavy increase in trunk and junction traffic, following the reduction in tariffs over two years ago, necessitated the urgent provision of many new trunk and junction cables. In the Eastern District some 400 miles of route required accurate measurement for cable specifications and the spacing of loading points.

In the initial stages, measurement was made by chain and pins, this being regarded as the standard method. It must be admitted, however, that the conditions under which men are called upon to perform chain measuring duties are not conducive to reliable results. Unless arrangements are made for co-operation by a third member of the party (with a vehicle), the chain measurers must of necessity be burdened with stakes, hammer, maps, tape, personal requisites, etc. The measurement of long rural routes, sometimes during inclement weather, thus becomes an exacting task, slow progress and unreliable results being almost inevitable. As an example, it was seen that at least 64,000 chain lengths would be involved in the measurement in both directions of 400 route miles and this would occupy the equivalent of two men's time for six months.

Apart from the attendant disadvantages, it appeared that chain measuring from an efficiency standpoint was not in keeping with present-day standards, and efforts were, therefore, made to devise a better system, such as an electrical or mechanical recorder.

A hand measuring wheel has, it is believed, been sometimes used for this purpose but it is a slow method and very liable to errors due to deviations from the straight. Also, a man pushing a wheel in front of him, for mile after mile, presents a rather ludicrous picture.

The recorder, however, in its latest form, enables measuring work to be carried out with dignity, and its degree of efficiency is such that the 400 miles of route quoted above can be measured in the equivalent of two men's time for three weeks.

First Experiments.

An accuracy of about 1 yard in 2,000 was aimed at in spacing loading points to allow as much margin as possible for later unforeseen deviations in the duct or cable track. The sidecar wheel of a motor-cycle combination seemed to be the most suitable wheel for driving a recorder, the back wheel of a combination being subject to spin or slip and the front to steering deviations.

The first tests made were primarily to determine the degree of accuracy which would be obtained. A subscriber's meter, from a C.B. telephone exchange, was rewound for low voltage working and joined via the motor cycle battery to a brush and a cam fixed to the sidecar wheel. Headphones were connected via a two-volt tapping from the battery to the auxiliary

contacts of the meter to prove its regular operation to the sidecar observer. The degree of accuracy, and consistency of results obtained, showed that further experiments were justified.

For the next experiment the cam and brush were replaced by a flexible speedometer cable drive from the sidecar wheel to a car type distributor, the cam of the latter being modified to give one contact per wheel revolution.

All-mechanical Positive Drive Recorder.

At this stage it was established that reliable results could be obtained, and it was realised that the recorder could not only be used to check chain-measured distances, but also to record the required measurements and spacing without previous chaining. The limiting speed, however, at which the electrically operated

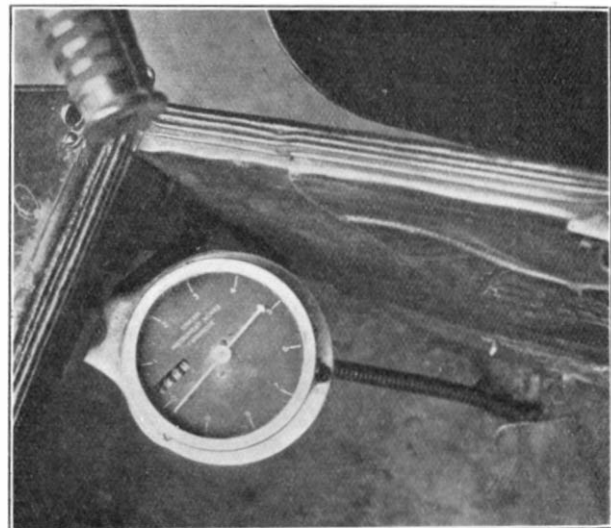

FIG. 1. - ROUTE DISTANCE RECORDER.

meter worked satisfactorily was about 20 miles per hour and although such a speed was in itself adequate, a greater factor of safety was necessary. Furthermore, a positive mechanical drive to the meter or recorder was desirable.

Fig. 1 illustrates the recorder now used. The flexible speedometer cable is direct coupled to the centre needle which in turn is geared by a 10 to 1 worm reduction unit to the digit recording part of a subscriber's meter. The reduction gear is packed with grease and the recorder has shown no appreciable signs of wear after nearly two years' use.

Fig. 2 shows the method of drive from the wheel. The wheel spindle was drilled through the centre and a square ended spindle, fixed to a hub cap, was passed through the wheel spindle to engage with the flexible cable drive. The casing of the latter is fixed to and is concentric with the wheel spindle.

When the operation of the recorder is not required it is disconnected by simply replacing the inner spindle and cap by the normal cap. The drive is positive throughout, no friction couplings or grub screws being used.

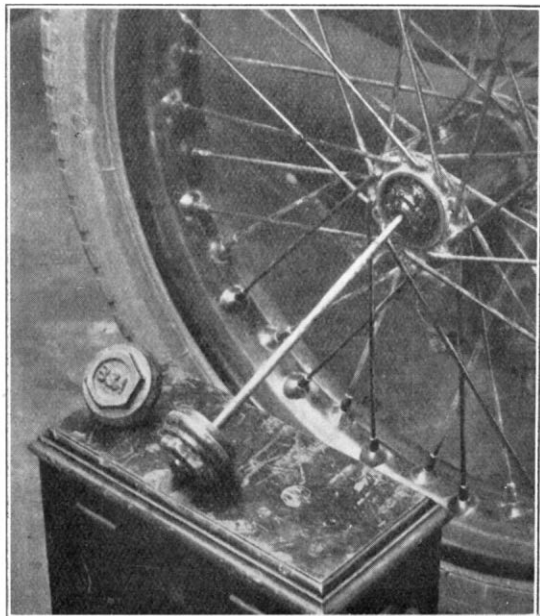

FIG. 2.—METHOD OF DRIVE FROM SIDECAR WHEEL.

The centre hand revolves once per wheel revolution and the dial is divided into tenths. The digit counters record the wheel revolutions and fractions of a wheel revolution are shown by the centre hand.

Use of Recorder.

Experiment has shown that for a passenger of average weight a sidecar tyre pressure of 38 pounds per square inch gives the most consistent results.

As the recorder reading for a given distance varies slightly with tyre wear, it is necessary to obtain the reading for a standard distance before the machine is used for actual route measurement and loading point spacing. At Cambridge, where the motor cycle is stationed, a distance of 2,000 yards (i.e. the standard loading section length) has been carefully chain measured along a straight unfrequented road on the outskirts of the town and the position denoted by marking posts. This standard length is occasionally traversed two or three times by the motor cycle before the latter is driven to the actual site of the route to be measured.

It is important to ensure that the combined weight of the passenger and load in the sidecar is approximately the same in actual use as for the calibration runs. It is also important that the tyre pressure is maintained at 38 pounds per square inch.

2,000 yards is equivalent to a recorder difference reading of about 900, depending on the condition of the tyre. A difference of more than 1 yard (i.e. about .5 on the recorder) between successive runs over the standard 2,000 yards indicates something amiss, such as a slow puncture in the sidecar tyre. Similarly, unless the road is very winding, there should not be a greater difference than 2 yards in successive readings over a 2,000 yards loading section on the actual route. In practice it is found that successive readings taken with the recorder differ less than successive measurements taken by chain. Distances are normally checked by traversing the route twice.

It has been found that the most accurate results are obtained when the motor cycle is run on the same side of the road as the proposed duct or cable track, thus minimising errors due to bends in the road. Hence if the proposed route crosses from one side of the road to the other, the route on each side of the road is measured separately and the road crossing measured by a tape.

Similarly, portions of the route which would cut corners on wide grass verges, or which would otherwise deviate appreciably from the line taken by the sidecar wheel, need to be separately chain or tape measured. Such conditions, however, are infrequent.

Some allowance, as indicated by experience, is sometimes necessary when the motor cycle is swung out from the side of the road to overtake stationary or slow moving vehicles.

In busy towns, owing to traffic obstructions, and also along very winding roads, it is best to chain measure in the first place, but in every case the motor cycle recorder is used to check roughly these measurements. A more accurate check is, of course, possible when it is made under quiet traffic conditions, e.g. in the early morning.

Although a speed of 30 m.p.h. can be maintained along an open road, the average speed will vary considerably, depending on the conditions of the route and the time taken at stops for calculations, records and chain or tape measurement of short sections.

Conclusion.

Over 500 miles of new cable route in the Eastern District have now been satisfactorily measured and spaced for loading points by the above means. Of this distance about 36 miles was chain measured through congested town thoroughfares. The method has also been used to advantage for the measurement of pavings and grass margin under which ducts were to be laid.

In conclusion, the authors hope and anticipate that the recorder will continue to prove its worth in the many additional cable schemes which are now being planned.

Notes and Comments

Sir George Lee, O.B.E., M.C., B.Sc., M.I.E.E.

WE were particularly pleased to see the name of the Engineer-in-Chief in the first Honours List of the new reign, for we regard the knighthood conferred on him as a recognition not only



of his personal services to the country but of the work in the whole sphere of telecommunications carried out by the Post Office Engineering Department under his able guidance.

Sir George is best known for his pioneer work in radio communication which gained him world-wide recognition. His interest in this branch of telecommunications is still very active, and among the many offices he holds he is the Chairman of the Radio Research Board, a Vice-President of the American Institute of Radio Engineers, and a Vice-President of the Institution of Electrical Engineers.

We offer Sir George our sincere congratulations on his latest honour.

Post Office Accounts

The Post Office Accounts for 1936 show that new records have been achieved in almost all directions. The number of telegrams increased by over 26 per cent., long distance telephone calls by 15.5 per cent. and local

telephone calls by 8 per cent. Increases of no fewer than 191,204 telephones and 1,371 call offices were recorded, and the line mileage grew by 722,000 to a total of 12,496,000 miles.

Despite the numerous rate and rental concessions there was a record surplus, after charging interest on capital, of £12,539,110.

We congratulate those responsible for the marked change in Post Office policy in recent years on the extremely fine results obtained.

The Speaking Clock

Readers of the article on the Speaking Clock which appeared in the January issue of the JOURNAL will be interested to learn that from the inauguration of the time service on July 24th until the end of 1936, 5,153,638 calls were made to the clock.

Binding

This issue is the first of Volume 30 and readers are reminded of the binding facilities which are available for past volumes. Full details will be found on page 80.

Ten-Year Index

A few copies of the Index of Volumes 19 to 28 are still available. Copies may be obtained at a price of 6d. per copy from the Managing Editor or through local agents.

Circulation

Just over a year ago we were able to announce that for the first time the quarterly sales of the JOURNAL had passed the 10,000 mark. The demand has since grown so steadily that 14,000 copies of the present issue have been printed. An increase of 40 per cent. in so short a time appears to indicate that the policy of the Board of Editors is meeting with general approval. The Board is not resting content but is always pleased to receive suggestions regarding improvements.

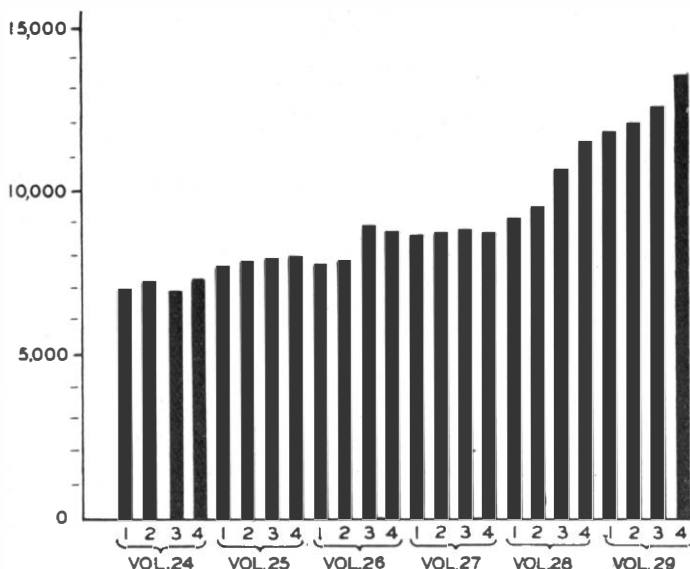

T. Walmsley, Ph.D., M.Inst.C.E., A.M.I.E.E., M.I.R.E.



Dr. T. Walmsley has been appointed Staff Engineer in charge of the new Branch at Headquarters charged with the study and control of systems of line distribution of broadcast programmes.

After receiving early education in the local Grammar school at Burnley he had several years' experience as a student and junior assistant with several electric supply authorities. He joined the Metropolitan Power Section of the Post Office in August, 1908. In 1920 he was transferred to the Wireless Section, and after acting as resident engineer during the erection of Rugby radio station from 1923 to 1925, returned to Headquarters at a time when developments on short-wave transmission were being actively pursued. For several years he was engaged on the design of external equipment such as masts and aerials and was responsible for an original design of beam antenna which is used on some Post Office services. In 1933 he was appointed Assistant Staff Engineer and took charge at Headquarters of all radio development and construction work.

Dr. Walmsley has done important work on committees of the Department of Scientific and Industrial Research and has also contributed papers to the Institution of Civil Engineers, the Institute of Electrical Engineers and the Institute of Radio Engineers. He shared with Colonel Angwin an award of the Telford Premium of the Institution of Civil Engineers for a paper on Rugby Radio Station and has twice been awarded the Duddell Premium by the Institution of Electrical Engineers for papers on antenna systems. The speedy development of the new Branch at Headquarters under his able guidance can be assured and this new extension of the Department's activities will be watched with lively interest by all of his colleagues.

A. J. G.

R. M. Chamney, B.Sc., Assoc.M.Inst.C.E., A.K.C.

R. M. Chamney entered the service of the National Telephone Company in August, 1909, and until the date of the transfer was chiefly engaged on research work in connection with local lines and transmission.

After the transfer he joined the Post Office Research Section and became closely associated with the late Mr. C. Robinson in line transmission measurements and the development of the long hoped for telephone repeater. Mr. Chamney was in at the start of this development, early trials with the Shreeve and Brown microphone amplifiers being followed by enthusiastic work after the acquisition of a Lieben Russ valve and De Forrest Audion, which were about the only thermionic devices then available.

The pioneer work that had been done proved invaluable during the war period when Mr. Chamney was engaged on the making and maintenance of repeaters to augment the lines of communication. All the apparatus for these repeaters, including valves, was designed and produced in the Research Section. In the post-war years developments proceeded at a great pace and the literature of the I.P.O.E.E. bears witness to the activities of Robinson and Chamney in the telephone repeater field.

Difficulties naturally arose as the use of repeaters extended and the distance over which speech was transmitted increased. These were successfully overcome by many ingenious devices, a notable example being the Echo Suppressor developed by Mr. Chamney with Mr. C. Robinson, an invention which is used all over Europe at the present time.

In 1927 Mr. Chamney was transferred to the Transmission Section under Mr. A. B. Hart, and in 1932 his activities were transferred to the Inland Transmission



side of the Lines Branch, where he was directly concerned in the provision of "Zero" 4-wire backbone circuits.

Mr. Chamney brings to his new position as head of the Lines Branch a remarkable continuity of experience of all the modern advances in line transmission, and with

his well-known energy and enthusiasm it is certain he will maintain that high standard of technical progress and efficiency of the British Communications network which has been the ideal of his able predecessor.

F. O. B.

Retirement of Capt. J. G. Hines, M.I.E.E.

Captain Hines retired, after a Post Office service of 43 years, on February 26th. He entered the Engineering Department in January, 1900.



At the time of the transfer of the National Telephone Company to the Post Office in January, 1912, he was appointed to the Executive Engineer's position in the City Internal Section, London. During the War he served with the Signal Service and at the conclusion of the War he was placed in charge of the Technical Section in the London Engineering District and at once commenced the preparation of a scheme for the division of London into automatic exchange areas. The scheme not only included the preparation of complete plans of the area but also the necessary economic calculations in order to show the relative advantages of the various possible schemes.

The methods employed were described in his paper read before the Institution of Post Office Electrical Engineers and later before the Institution of Electrical Engineers.

In 1931 Captain Hines was appointed Staff Engineer in charge of the Lines Branch at Headquarters, following Mr. A. B. Hart. During his tenure of office the main backbone circuits were converted into underground 4-wire circuits worked on the "zero" loss principle, and this, together with the "Demand" system, stimulated traffic to a remarkable degree. He became the chief British delegate on the third C.R. of the C.C.I.F. and took very great interest in international telephony.

Captain Hines leaves the Department with the best wishes not only of his own staff, but also of very numerous friends all over the country who have known him in earlier days or have experienced his kindly and helpful attitude during the many visits that he has made to every District, and it is safe to say that his popular personality will leave a great blank in the Engineering Department and that his loss will also be felt in Headquarters Building, where he was known almost as well as in his own Department.

R. M. C.

Book Review

"Radio Operating Questions and Answers," (Sixth Edition), by Arthur R. Nilson and J. L. Hornung, 427 pp. 104 ill. 15s. McGraw-Hill Publishing Co., Ltd.

This book is written specially for students and operators who are about to take the United States Government examination for a radio operator's licence. The questions cover a wide range of subjects, including Valve, Arc and Spark transmitters; receiving apparatus, direction finders, storage batteries and broadcasting transmitters.

A large proportion of the questions deals with specialised equipment which is never seen or used in this country, e.g., Question 2 is "How many amperes does the filament of a UV204 (250 watt) tube draw? What is the proper filament voltage and current for a UV 204 A tube and for a UV 211 (50 watt) tube?"

As ship operators are examined as to their knowledge of the construction and working of equipment which they would actually be called on to handle, and as British ships are almost wholly equipped with British apparatus, a large number of these questions would not furnish useful information to British candidates.

There are, however, a large number of questions which are of a general character which might be asked about any type of equipment, e.g., Question 376, "State Ohm's Law in full. How would you find the resistance in a circuit if the voltage and current are known?"

There is a considerable amount of interesting information in this book in regard to United States practice and some of the answers occupy several pages giving particulars of radio transmitters with complete wiring diagrams.

One curious omission occurs, there is no reference to the alarm signal. Possibly this is because auto alarm apparatus is not fitted to American ships. One would expect, however, that operators would be called upon to know something of this signal which has been authorised by international regulations.

To sum up, this book will have some interest for designers of equipment who seek information regarding American practice, and it might also be of limited interest to operators, but it is considered its chief sphere of application will be in the United States. The fact that it has run into six editions testifies that it meets a definite demand.

A. J. G.

Book Reviews

"Instrument Transformers," by B. Hague, D.Sc. (Lond.), Ph.D. (Glas.), F.C.G.I., D.I.C., M.I.E.E., etc. 634 pp., 300 ill. Pitman, 35/-.

In the measurement of large currents and high voltages and also in the design of protective devices it becomes necessary to introduce transformers so that these measurements or operations may be made safely and conveniently on secondary circuits. Introducing these transformers makes it very necessary, however, to take precautions that errors, due to ratio, phase displacement, etc., are not introduced and that the use of transformers does not become a source of breakdown in the supply system.

The design of these transformers is, therefore, of the highest importance and a need has been met by this book in which the author has dealt very comprehensively with the theory, construction, performance and methods of testing so that full information may be available for designers, engineers, test rooms and research laboratories.

The first part, forming half of the book, deals with the theory and characteristics of instrument transformers, and the second part with the instruments used in their testing. The third, fourth and fifth parts deal with testing and methods of test, a number of methods being included which, while not generally adopted in practice, the author feels should be put on record as they may prove useful in other fields.

A useful preliminary chapter summarises a number of national specifications so that the differences of technical practices followed in different countries may be clearly seen. The book is completed by a number of appendices and a very complete bibliography, a large number of references to contemporary literature being also included in the text.

There is no doubt that the book should prove valuable to designers and to the staff of test rooms and research laboratories, while the advanced student who is considering specialisation will also find it a most useful text book.

J. Mc. G.

"Outdoor High Voltage Switchgear," by R. W. Todd, A.M.I.E.E., Assoc. A.I.E.E., and W. H. Thompson, A.M.I.E.E. 436 pp. 259 ill. Pitman, 42/-.

Although dealing mainly with switchgear for outdoor high voltage substations, the greater part of the subject matter also applies to plant installed in buildings, the main exception being the effect of atmospheric conditions on the design of insulators.

Following a preliminary chapter on the layout of outdoor substations, the difficulties in design, manufacture and testing of H.V. insulators of all kinds are dealt with. Details of air break switches for load breaking and isolating purposes are followed by a full discussion of contacts, arc interruption phenomena and the effect of re-striking voltage. This leads up to the consideration of the design of oil circuit-breakers and metal clad switchgear and the methods employed to quench the arc formed on breaking the circuit, while consideration is also given to connections and to protective gear against lightning, surges and faults.

The book is chiefly intended for designers, dealing as it does with the theoretical and practical aspects of design in detail, but will be of interest to all concerned with the use design and maintenance of E.H.T. supply systems.

J. Mc. G.

"Principles of Radio Engineering," by R. S. Glasgow, M.S. 520 pp. 344 ill. 24s. McGraw-Hill Publishing Co., Ltd.

This book is intended primarily as a text book for students of electrical engineering, and is based on lecture notes used by the author for a number of years in a course on radio communication given at Washington University. Thus, although this is a new book the subject matter has been in use for instructional purposes and has been tested out.

A knowledge of fundamental laws of electricity and magnetism is assumed. Alternating current theory is covered very thoroughly but concisely in Chapter 1 of 27 pages, so this does not seriously encroach on the subject matter.

Chapter 2 deals with series and parallel resonant circuits, while Chapter 3 is on the properties of coils and condensers. This chapter contains much useful matter on magnetic alloys and their use at high frequencies. The subject of electrolytic condensers is also touched upon.

Chapter 4 is on coupled circuits while Chapter 5 deals with oscillating circuits. Chapters 6 to 13 cover the whole range of valve technique from fundamental properties to audio frequencies, amplifiers, radio frequency amplifiers, oscillators, modulation, detection and receiving systems.

The book is completed by a most useful chapter on antennae and wave propagation, which contains much information on transmission lines with which the competent radio engineer must nowadays be familiar. Methods of coupling radio equipment to lines and lines to antennae are well described.

The author, in dealing with electromagnetic radiation, has avoided the vector method in favour of the less concise but more generally understood methods of the integral calculus. This is considered to be an advantage as the former method calls for specialised mathematical knowledge.

To sum up this seems to be an excellent work. It is not overburdened with mathematical analysis, but when such analysis is necessary it has not been avoided. It contains information which, if not original, can be obtained only by consulting a number of other works such as Terman, Pierce and Johnson or some of the numerous papers which have appeared in recent years. It can therefore be recommended as a text book for students and as a reference book for engineers. One of its great advantages for the former purpose is the collection of numerical problems at the end of each chapter. The book is on principles rather than practices, and thus voice-operated devices and privacy apparatus used on radio telephony, although referred to, are not described. ● On the other hand the negative feed back amplifier is described and a brief analysis of its principles is given.

Nothing appears in this book about filters. Although a comprehensive treatment of this subject requires too much space for a volume of this kind, it is thought that a brief and concise treatment of this subject would have enhanced the value of the work, particularly as much of the groundwork is covered in the section on transmission lines.

The book is fully referenced and appears to be reasonably clear of errors. A misprint in expression 9 on page 4 is noticed, in which "dwt" should read "dt."

A. J. G.

The Institution of Post Office Electrical Engineers

RETIREMENT MEMBERS.

The following members, who have retired from the Service, have elected to retain their membership of the Institution:—

G. C. Geisler, 65 Kensington Gardens Square, Hyde Park, W.2.

A. Kemp, 11 Fairway, Sedgely Park, Prestwich, Manchester.

CORRESPONDING MEMBERS.

The following have been elected:—

S. J. Kanjilal, B.E., C.E., A.M.I.E.(Ind.), Posts and Telegraphs, Calcutta, India.

N. B. Fletcher, Posts and Telegraphs, Malacca, Malaya.

RECENT ADDITIONS TO THE INSTITUTION LIBRARY.

- 1249 Elementary Survey of Modern Physics.—G. F. Hull. (1936, Amer.)
 1250 Photography To-day.—D. A. Spencer. (1936.)
 1251 Principles of Radio Engineering.—R. S. Glasgow. (1936, Amer.)
 1252 Physical and Chemical Constants and Some Mathematical Functions.—G. W. C. Kaye and T. H. Laby. (1936.)

- 1253 Television Optics: An Introduction.—L. M. Myers. (1936.)
 1254 Interference Suppression: the Causes and Cure of Electrical Interference with Radio Reception.—Belling & Lee, Ltd., Research Dept. (1936.)
 1255 Mathematics for the Million.—L. Hogben. (1936.)
 1256 Differential and Integral Calculus. Vol. I.—R. Courant, Trans. by E. F. McShane (1934 cont.).
 1257 Differential and Integral Calculus. Vol. II.—R. Courant. Trans. by E. F. McShane. (1936, cont.)
 1258 Electricity and Magnetism for Engineering Students.—A. W. Hirst. (1936.)
 1259 Drafting for Engineers: A Textbook of Engineering Drawing.—C. L. Svensen. (1935, Amer.)
 1260 Specifications for Building Works.—W. L. Evershed. (1935.)
 1261 Electrical Insulating Materials: An Engineering Treatise on the Production, Characteristics and Uses of Electrical Insulating Materials.—H. Warren. (1931.)
 1263 Differential Equations for Electrical Engineers.—P. Franklin. (1933, Amer.)
 1264 Classical Theory of Electricity and Magnetism. M. Abraham. Revd. by R. Beckner. Trans. by J. Dougall. (1932, cont.)

Junior Section Notes

Aldershot Centre

The meeting on February 24th was devoted to a lecture on "Secondary Cells," by Mr. J. E. Porter. The construction and operation of both old and new types of secondary cells were described, and the lecturer then went on to deal with the recent designs of power plant with which these cells were used.

Great interest was displayed in the automatic methods of battery supply to be used with U.A.Xs., and smaller non-director automatic exchanges, and an interesting discussion brought a very informative and enjoyable evening to a conclusion.

Edinburgh Centre

The following meetings have been held since the last issue of the JOURNAL:—

- January 11th, 1937.—"Colour." Mr. J. M. Wright.
 January 18th, 1937.—"Maintenance." Mr. F. A. Hough, M.Sc.(Eng.), A.C.G.I.
 February 1st, 1937.—"Unit Auto Exchanges, No. 7." Mr. D. B. Whyte.
 March 1st, 1937. "Cable Balancing." Mr. W. McKendrick.

The Committee are indebted to the authors of these instructive papers, each of which provoked interesting discussion. Mr. McKendrick's paper on "Cable Balancing" was illustrated by lantern slides kindly lent by the Engineer-in-Chief's Training School.

There has been an improved attendance at these meetings, but the Committee feel that greater advantage could be taken of the educative facilities offered by the Centre, and would be glad to enrol many more members.

The local prize of £1 is. for the best paper read before the Centre during the 1935/36 session has been awarded to Mr. D. G. Buchanan for his paper on "Petrol from Coal."

Manchester Centre

The programme for the second half of the 1936/7 session is as follows:—

- January 11th.—"Automatic Exchange Clerk of Works." E. Greenwood, Esq.
 January 16th.—Visit to Connollys' Cable Works.
 February 2nd.—"Advice Note Control." A. Jones, Esq.
 February 6th.—Visit to Rochdale Fire Station.
 February 18th.—"Precision Testing." G. H. Hodson, Esq.
 February 24th.—Evening Visit to British Oxygen Company.
 March 9th.—"Voice Frequency Keysending from Manual Exchanges." W. C. Huff, Esq., A.M.I.E.E.
 March 13th.—Visit to Fergusson Pailin & Company.
 April 1st.—"Reinforced Concrete and Its Applications." W. Davies, Esq.
 April 10th.—Visit to Manchester Town Hall.
 April 20th.—Annual General Meeting, followed by a Debate.

Three extremely interesting visits were paid during the first half of the session to the Manchester Docks, a Miner's Rescue Station and to the Manchester office of the Allied Newspapers, Ltd. The visit to the newspaper office was preceded by a talk a few days before by the Publicity Manager of the Allied Newspapers, this being the first occasion on which the Centre has had a paper from a lecturer not on the staff of the Department.

The attendance at meetings during the first half of the session was rather poor, but it is anticipated that an improvement will be apparent during the second half of the programme as the new members realise the advantages to be gained from the attendance at Junior Section meetings.

Portsmouth Centre

At the annual general meeting the following officers were elected for the 1936-37 session:—

Chairman—Mr. G. G. H. Ogburn, Inspector.
Vice-Chairman—Mr. H. J. Robinson.
Secretary-Treasurer—Mr. C. H. Hishon.
Committee—Mr. T. Pearce, Mr. P. Kerwood, Mr. L. E. Elgar.

The monthly meetings to date have proved very successful, and it is hoped that the further meetings will meet with similar support. The following papers will be read:—

February 24th.—“Transmission Notes,” by Mr. V. Smith, Asst. Engr.

March 23rd.—“Our Ideas,” by Messrs. Whittle and Jarrett (Youths in Training).

April 21st.—“Elementary Principles of A.C. Machines,” by Mr. G. Millen, Asst. Engr.

It is again pointed out to members that the library facilities are available and that arrangements are in progress for the visit to the Pirelli Cable Works. Further details of this will be given in due course.

It is gratifying to note that the meetings are receiving the full support of the supervising officers, some few of which are always to be seen at the meetings.

Under the auspices of the Portsmouth Junior Centre a well-attended Staff Dinner took place at the Savoy Café, Southsea, on February 26th.

The toast of “The Post Office Engineering Department” was proposed by Mr. F. W. Friday, A.M.I.E.E. (Sectional Engineer), and replied to by Mr. T. Cornfoot, M.I.E.E. (Superintending Engineer).

Mr. F. Gibbs gave the toast of “The Visitors,” to which Mr. Spafford (Surveyor) responded.

The “I.P.O.E.E. Junior Sections” was proposed by Mr. G. F. Millen, A.M.I.E.E., and replied to by Mr. C. J. Willmot. The toastmaster was Mr. C. J. Webster.

During the evening an excellent musical programme was rendered.

Preston (Lancs) Centre, 1936-37

The Centre has been most successful. There has been a marked increase in the attendance at all meetings, and what is most important, a very “lively” interest shown in each paper given, especially at “Question Time.”

The membership this session is 40. A very pleasing total.

The programme carried out was as follows:

Nov., 1936	T. A. B. Harrison	“Electric Organs.”
Dec., 1936	W. K. Hinningham	“Cathode Ray Tubes.”
Jan., 1937	E. T. Edleston	“Radio-Television.”
Feb., 1937	G. H. Wood	“Dynamamos.”
Mar., 1937	T. S. Wylie	“High Tension Transmission.”

We extend our very grateful thanks to the above speakers for their excellent contribution.

We would like to make a special appeal to all our members to be present at the Annual General Meeting to be held in the usual place, on April 21st, 1937.

L. H.

Southampton Centre

The 1936-37 session has so far been successful with a membership of 48. The following officers were elected for the ensuing year:—

Chairman—C. S. Hale.
Secretary-Treasurer—N. E. Dodridge.
Committee—Messrs. E. Andrews, R. J. White, F. Baker, R. Maggs, C. F. Middleton and L. T. Jennings.

The programme for the session was:—

October 15th.—“Subscribers’ Fittings,” by R. J. White.

November 18th.—“Odd Thoughts on Transmission,” by V. Smith.

December 17th.—“Some Traffic Views of Engineers’ Work,” by F. V. Florance.

January 21st.—“Internal Combustion Engines,” by N. F. Fletcher.

February 18th.—“Underground Construction,” by C. Hislop.

March 18th.—“Teleprinters,” by E. G. Miller.

A Staff Dinner under the auspices of the Southampton Centre (Junior Section) of the I.P.O.E.E., took place in the Lounge Hall of the Civil Service Sports Club on Friday, January 15th. There were 81 members and visitors present. In the absence of Mr. T. Cornfoot, M.I.E.E. (Superintending Engineer), Mr. V. Smith (Assistant Engineer) gave the toast of “The Department,” which was replied to by Mr. F. W. Friday, A.M.I.E.E. (Sectional Engineer). The “Southampton Centre Junior Section” was next given by Mr. G. F. Millen, A.M.I.E.E., and replied to by N. E. Dodridge (Local Secretary). The “Visitors” was given by F. Baker (Committee), and was replied to by Mr. Hynaston (Traffic Superintendent).

The chair was taken by Mr. H. Gilpin (Inspector) in the absence of Mr. C. S. Hale (Chairman Junior Section).

The company included our colleagues from the Portsmouth, Winchester and New Forest sections.

An excellent paper was read before the Southampton, Junior Section at Ogle Road Lecture Room, on Thursday January 21st, entitled “Internal Combustion Engines,” by N. L. Fletcher, of the Portsmouth Junior Section.

Mr. Fletcher gave a detailed history and explanation of the internal combustion engine, both Petrol and Diesel, illustrated by excellent diagrams and explanatory notes. The paper was appreciated by all. Senior Section members present were F. W. Friday, Esq., A.M.I.E.E. (Sectional Engineer), S. Moody, Esq. (Assistant Engineer), F. V. Florance, Esq. (Assistant Traffic Superintendent) and A. Blanchard, Esq., of the Winchester Staff.

Mr. Friday expressed appreciation of the lecture.

C. S. Hale, Esq. (Inspector), was Chairman.

The sixth meeting of the 1936/7 session was held at Ogle Road on February 18th, and a paper by C. Hislop, entitled “Underground Construction and My Day’s Work,” was read to an audience of 40.

Prior to the meeting a presentation was made to Mr. A. F. Mockford, Local Secretary, Southampton Centre Junior Section, 1934/6, of a canteen of cutlery, suitably inscribed. The presentation was made by Mr. F. W. Friday, A.M.I.E.E. (Section Engineer).

A tribute was paid to Mr. Mockford by Mr. Friday, who spoke of the forming of the Centre and its good work.

Mr. Mockford, in reply, said the success in the past had been due to help given to him by the Committee, especially Mr. C. F. Middleton. The paper was read and questions put *re* Balancing Cables, etc. Mr. Friday gave a brief résumé on the characteristics of cables ex-Factory, and gave an explanation why the cables were not scheduled at the Factory.

Visitors from the Traffic Branch were present.

A vote of thanks was given by Mr. F. W. Baker and seconded by Mr. E. Andrews.

The earnest support of all members is requested in forwarding suggestions and subject matter for the 1937/8 session.

The Chairman, Secretary and Committee wish to thank all members for their support during the 1937/8 session.

District Notes

North Wales

CIVIC OPENING OF TELEPHONE HOUSE, BIRMINGHAM.

On January 21st, 1937, the Ceremonial Opening of Telephone House was performed by the Chancellor of the Exchequer, Mr. Neville Chamberlain, who was introduced by the Postmaster-General, Major Tryon. Many influential guests were among the 400 who were present, and the proceedings were opened by Mr. Braund, the Postmaster-Surveyor of Birmingham, asking Major Tryon to address the gathering. Following this the Chancellor in his speech made humorous references to the telephone in its early days and recalled experiments with telephone receivers, with a piece of string as the line, which he had carried out with one of the sons of the great Huxley when they were boys at school.

After declaring the building open, Mr. Chamberlain operated a switch which inaugurated a sound tour of the building. Details of this interesting scheme are given later.

A vote of thanks to Mr. and Mrs. Chamberlain was moved by the Lord Mayor of Birmingham.

Mr. Faulkner, the Superintending Engineer, referred to the rapid growth of the telephone system of the world and drew attention to the all-important part which the thermionic valve had taken in the development of the science of telephonic communication.

The ceremony was electrically recorded by the B.B.C. and broadcast in the evening programme of the Midland Regional Transmitter.

After the official opening refreshments were served and the guests conducted in parties on a tour of the building.



Photo]

[Birmingham Gazette.

The photograph shows Mr. Neville Chamberlain making some happy remark in the course of his speech, with Mr. Faulkner on the right evidently enjoying the joke. On the left (with clasped hands) is the Postmaster-General, also smiling. The background is a crazy screen depicting the chief architectural and industrial features of Birmingham.

Engineering Details.

The engineering and general organising arrangements were undertaken entirely by the local staff of the various branches concerned. Every detail was carefully planned

to operate with that exact precision necessary for perfect co-ordination.

One of the chief features of the opening ceremony was the production of a "sound" picture, incorporating the sounds of the operation of power generators, auto-telephone apparatus, and including the District Manager's Department, by the operation of adding machines in the Accounts Section, together with the noise produced by a coin sorting and counting machine, the latter forming an important link in the collection of telephone kiosk fees.

This "sound" picture was obtained by means of microphones fitted in various parts of the building. The microphones also incidentally served for the requirements of the B.B.C. in connection with their Blattnerphone recording, which was included in the evening News broadcast programme. The whole of the sound programme was amplified, and fed to loud-speakers situated in the ceremonial hall for the benefit of the guests.

About one mile of wiring was necessary from the various microphone points to a control room centrally situated in which the B.B.C. installed the necessary apparatus for their recording, which was actually carried out at Broadcasting House over special lines.

In order to provide suitable signalling throughout the microphone network for the benefit of the various commentators, a common feed from the amplifier output was connected to head-gear receivers installed at each microphone point, and by this means the commentators were able to listen to the whole programme, and so determine the precise point at which their particular script was required. The monitor control circuit was wired through breakjacks in the control room, so that if necessary each commentator could be instructed individually without interrupting or interfering with the other listening points.

Considerable rehearsing was necessary beforehand, and the commentators were chosen from the various staffs concerned by means of test auditions. Finally, scripts were prepared relating to each specific subject, and a state of perfection was reached during the rehearsals which guaranteed the success of the scheme.

A circuit was also arranged to illuminate an electric lamp of symbolic design, situated on the platform table, so that when the Chancellor operated a switch when declaring Telephone House formally opened, this lamp was illuminated in synchronisation with a signal lamp situated in the power room, which served as the starting signal for the first portion of the sound effects, which were arranged in the following order:—

- (1) *Power Room.*—Starting up of generators, air blowers, and emergency oil plant, with description by the commentator.
- (2) *Apparatus Room Demonstrator Set.*—The complete sequence of a call was broadcast and detailed by the commentator.
- (3) *District Manager's Accounts Room.*—From here the sound of adding machines was broadcast with a commentary of details of the number of staff engaged and the amount of work handled. The sound of the operation of the automatic coin sorting and counting machine was also included at this point.
- (4) *Trunk and Toll Switch Room.*—The general room "noise" was broadcast, with a "close-up" effect of telephonists handling general calls and enquiries. A feature of this commentary

was the special arrangement of the script, which was read simultaneously by two telephonists and resulted in a perfect impression of telephone traffic, without involving actual calls.

It was also necessary to provide a high degree of illumination on the platform to facilitate the taking of a film by the news reel camera men and for the press photographers. This was effected by suitably placed floodlights of incandescent type, consuming a total power of 15 kilowatts. The resulting light was of the order of 30,000 candle-power, and the diffusion was such that glare was practically excluded.

REGIONAL TRAINING SCHOOL.

Arrangements have been made for the Birmingham Regional Training School to take over as from April next the A and B courses for Youths in Training, thus relieving the Central School at Dollis Hill.

Youths from the South Wales, the North Midland and the North Wales Districts will be catered for. The programme at present arranged allows for about 300 youths to be trained during the six months.

The other classes already held cover tuition in:—

- Plumbing and Joining.
- Overhead Wiring.
- Subscribers' and U.A.X. Fitting.
- Overhead Foremen's Duties.

On these courses some 800 men will pass through the school in the six months.

The accommodation question still remains acute as it has not yet been possible to find suitable permanent premises and the work is, therefore, being carried out under conditions which militate to some extent against the high efficiency which is aimed at. The results obtained, however, indicate fully that the school is functioning well, and that the classes are a real source of advantage to the men and to the Department.

Mr. R. SHEPPARD

Mr. R. Sheppard, Assistant Engineer in the Technical Section of the North Wales District died on 23rd February following a serious operation.

Mr. Sheppard, who was promoted to Shrewsbury in 1935, began his career in Birmingham with the National Telephone Company in 1910. He played an active part in the conversion of the extensive Birmingham area telephone exchanges to director automatic working.

He served with the Royal Engineers during the Great War and had considerable active service in France.

Well known in local cricketing circles he was both a first wicket batsman and a fast bowler and had played for the Birmingham Civil Service Team on a number of occasions.

His passing has left a gap which will be difficult to fill. Respected by all for his ability and sound judgment he was held in great regard by all who knew him for his kindness and understanding. His devotion to duty, unselfishness, honesty of purpose and an unflinching sense of humour were indicative of a great character—that of a perfect gentleman.

Scottish Region

GLASGOW AUTOMATIC TELEPHONES.

The programme for the conversion of the Glasgow telephone exchanges to automatic working is making substantial progress. The multi-office area will comprise a central exchange together with 34 satellite exchanges. Director working will be provided.

A new site has been acquired in Pitt Street, Glasgow, on which a new building will be erected to accommodate

the Central exchange, the automanual switchboard, mechanical Tandem, the maintenance control centre and the repeater station.

The initial equipment of the automanual exchange will comprise 315 positions and 10,000 subscribers' equipments will be provided initially. The Central exchange is designed to accommodate two 10,000 line units. The sites of all but one of the satellite exchanges have already been acquired, and an intensive building programme arranged with the Office of Works. The first automatic exchange to be opened will be Halfway, due to be completed in August, 1937. Four other exchanges will be opened early in 1938, and the peak of the conversion work will be reached in 1939 when the Central exchange and Trunk exchange transfers will be made together with ten other exchanges. The completion of the conversions is anticipated in 1942.

The Office of Works experienced considerable difficulty with the building foundations in Pitt Street, the site being unstable due to proximity to the River Clyde, and an extensive system of piling was found to be necessary. These difficulties have now been overcome, but a delay of approximately six months in the building programme for the Central building resulted.

In the meantime, telephone development in Glasgow has proceeded apace consequent upon the trade expansion which is being experienced amongst the heavy engineering trades in the District, including shipbuilding on the Clyde for the Admiralty, "Queen Mary's" sister ship No. 552, and other works arising from the national rearmament programme. These operations have necessitated special steps being taken in the existing manual exchanges to cover the development work entailed in providing for telephone services up to the transfer dates of the respective exchanges. Close co-operation is being maintained between the Sales, Traffic and Engineering staffs to ensure that there is no failure to meet the demands of the public, nor wastage of plant by over-provision. Manual equipment released from areas in England now being converted to automatic working is being utilised extensively, and a large local switchboard fitting staff is employed in adapting and completing the switchboards on site.

ABERDEEN-DUNDEE-EDINBURGH CARRIER CABLES.

Two cables, 24 Pr./40 for "Go" and "Return" respectively, are being provided and the work, which is being carried out under contract for the Department by Messrs. Standard Telephones & Cables, Ltd., of Woolwich, is making good progress. Particulars of the laying of the submarine link across the Tay Estuary were given in the JOURNAL for January 1937. Special difficulties were experienced in respect of the Firth of Forth crossing as the wood troughing containing cables along the permanent way on the Forth Bridge was full and required renewal. The opportunity was taken of replacing the wood casing by special steel casing and providing new cables. Technical particulars of this work will appear in a future issue of the JOURNAL. There is urgent need of additional trunk circuits north of Edinburgh, and it is anticipated that the new cables will be brought into use in July, 1937, to afford relief to the summer season's traffic.

OPENING UP OF TELEPHONE EXCHANGE SERVICE ON ISLAY.

On February 3rd and 4th last the completion of the work involved in extending the telephone service to Islay, one of the islands of the Inner Hebrides, was completed. U.A.X. No. 12 type exchanges were opened at Port Askaig and Port Charlotte and a country

satellite exchange at Portnahaven, parented on Port Ellen, was brought into service.

The other work involved in the extension, of which note has been made in a previous issue, was the provision of land lines and a submarine cable connecting Islay to the Mull of Kintyre, and the opening of a C.B.S.2 Manual Board at Port Ellen and U.A.X. No. 12's at Bowmore and Kildalton. The country satellite exchange equipment, one of the first to be brought into service in Scotland, is working satisfactorily.

RETIREMENT OF MR. J. W. WARNOCK.

A large and representative gathering met in the office of the Telephone Manager, Scotland West Area, on Friday, February 26th, 1937, to bid farewell to Mr. J. W. Warnock, Area Engineer, on the occasion of his retirement from the Service on reaching the age limit.

Mr. Richardson, Area Engineer, presided, and Mr. F. I. Ray, Telephone Manager, presented Mr. Warnock with a testimonial as a token of the esteem in which he was held by both the outdoor and indoor staffs. The various speakers paid tribute to Mr. Warnock's work as an organiser, as an engineer and as a colleague. Mr. Warnock acknowledged the gifts and the sentiments expressed in a suitable reply.

Mr. Warnock entered the service of the National Telephone Co. in 1893. He received an all-round training and acquired a sound practical knowledge of both the internal and external workings of the Telephone Service. He was associated with the pioneers of the telephone in Glasgow, and was responsible for the maintenance of the first switchboard installed in the city.

Transferred to the Post Office Service on January 1st, 1912, as an Assistant Engineer, Mr. Warnock was promoted to executive rank in 1929, when he took charge of the Glasgow South Section. On the introduction of Regional Working in February of last year, he assumed the role of Area Engineer. His total service amounted to almost 44 years.

Mr. Warnock takes with him the high esteem and the best wishes of the staff in his retirement.

Book Review

"Wireless Engineering," by L. S. Palmer, D.Sc. London : 544 pp. 353 ill. Longmans, Green & Co. 21/- net.

This book is a revised and augmented edition of the author's "Wireless Principles and Practice," published in 1927.

In the present work the copious bibliographies accompanying each chapter of the earlier edition have been omitted and about 100 pages of new matter have been included dealing with more recent developments in radio communication. The new matter includes information on the production, propagation and reception of ultra-short waves, the recent advances in knowledge of the ionosphere and its action on the propagation of wireless waves. Other topics which have been added include quartz oscillators, copper-oxide rectifiers, H.F. feeder lines, radio cable links and magnetron and other micro wave oscillators.

It is not clear why the change has been made in the title as the changes and additions have not altered in any way the character of the work, and the earlier title is considered to be more appropriate. In a work on wireless engineering one would expect to find information on the actual design of transmitting and receiving

South Western District

BRISTOL-PLYMOUTH 12 CHANNEL CARRIER SYSTEM.

A further stage in the development of telephone engineering was reached in December last when the above experimental system was successfully introduced. It was instrumental in affording considerable relief during the exceptionally busy Christmas period, owing to the number of additional circuits which it provided at short notice.

The present equipment provides for 36 circuits between Bristol and Exeter and the same number between Bristol and Plymouth, and of the 72 circuits so made available, 47 are in use. The remaining channels are at present reserved for the purpose of obtaining data regarding the stability of the system under working conditions.

The circuits have been working satisfactorily during the period for which they have been in use, and the absence of background noise is a noticeable feature of the transmission.

It is understood that an extension of the existing equipment is under consideration, which will double the number of channels now available.

South Lancs.

WYTHENSHAWE AUTOMATIC TELEPHONE EXCHANGE.

The above-named telephone exchange was opened on Saturday, December 12th, 1936, when approximately 500 subscribers were transferred from the Didsbury, Sale, Altrincham and Gatley exchanges.

The transfer was effected with only three faults. It is the 25th automatic telephone exchange opened in the Manchester area since the introduction of automatic working into the South Lancashire District in 1930.

RADCLIFFE AUTOMATIC TELEPHONE EXCHANGE.

The above-named telephone exchange was opened on Saturday, February 20th, 1937.

It was a "perfect" transfer. It is the 26th automatic telephone exchange opened in the Manchester area since the introduction of automatic working into the South Lancashire District in 1930.

equipment with typical examples of plant in the form of working drawings, etc.

The subject of radio-telephone services connected to land networks could have been treated more fully as only the simplest type of equipment is described. A bare reference is made to voice-operated devices (singing suppressors), but nothing is said about other associated equipment such as privacy devices and compandors. More extensive information on the efficiency and matching of feeder systems and some treatment of wave filters is also to be recommended.

One or two minor errors have been noticed, e.g., the note on p. 411 states that the Proc. of Inst. of P.O. Elect. Engs. are published by H.M. Stationery Office, while the meaning of the note on page 413 is not clear.

The book as a whole is of a high standard and will deservedly receive continued popularity as a text-book on the principle of radio communication. It should be pointed out, however, that it does not cover the whole requirements of the City and Guilds syllabus, although it goes well beyond it in several directions.

A. J. G.

Staff Changes

PROMOTIONS.

Name	From	To	Date
Walmsley, T.	A.S.E., E-in-C.O.	Actg. Staff Engr., E-in-C.O.	2-2-37
Walmsley, T.	Actg. Staff Engr., E-in-C.O.	Staff Engr., E-in-C.O.	1-3-37
Chamney, R. M.	A.S.E., E-in-C.O.	Actg. Staff Engr., E-in-C.O.	1-3-37
Manning, F. E. A.	Actg. A.S.E., E-in-C.O.	A.S.E., E-in-C.O.	21-1-37
Gracie, A. J. A.	Exec. Engr., E-in-C.O.	A.S.E., E-in-C.O.	24-2-37
Jolley, E. H.	Exec. Engr., E-in-C.O.	Actg. A.S.E., E-in-C.O.	24-2-37
Barker, P. L.	Asst. Engr., Eastern	Actg. Exec. Engr., E-in-C.O.	13-12-36
Roe, E. A.	Asst. Engr., N. Midland	Actg. Exec. Engr., S. Wales	31-1-37
Beighton, T. A.	Asst. Engr., S. Midland	Actg. Exec. Engr., S. Midland	19-11-36
Barker, P. L.	Actg. Exec. Engr. E-in-C.O.	Exec. Engr., E-in-C.O.	14-12-36
Roe, E. A.	Actg. Exec. Engr., S. Wales	Exec. Engr., S. Wales	1-2-37
Beighton, T. A.	Actg. Exec. Engr., S. Midland	Exec. Engr., S. Midland	To be fixed later.
Jarvis, R. F. J.	Actg. Exec. Engr., E-in-C.O.	Exec. Engr., E-in-C.O.	3-9-36
Franklin, R. H.	Actg. Exec. Engr., E-in-C.O.	Exec. Engr., E-in-C.O.	3-9-36
Smith, H. G.	Actg. Exec. Engr., S. Western	Exec. Engr., S. Western	10-11-36
Hopps, F.	Asst. Engr., N.E. Reg.	Actg. Area Engr., N.E. Reg.	To be fixed later.
Gifford, H. W.	Asst. Engr., S. Wales	Actg. Exec. Engr., S. Wales	24-2-37
Brown, A. H.	Asst. Engr., Scot. Reg.	Actg. Area Engr., Scot. Reg.	24-2-37
Crosse, J.	Insp., N. Ireland	Chief Insp., N. Ireland	28-11-36
Millard, A. E.	Insp., S. Western	Chief Insp., S. Western	14-12-36
Moon, F. H.	Insp., S. Lancs	Chief Insp., S. Lancs	4-10-36
Brown, E. P.	Insp., S. Midland	Chief Insp., E-in-C.O.	5-12-36
Hobbs, H.	Insp., S. Western	Chief Insp., S. Western	15-11-36
Sharp, J.	Insp., London	Chief Insp., London	1-11-36
Howard, A. A.	Insp., London	Chief Insp., London	1-1-37
Challinor, W.	Insp., London	Chief Insp., London	18-9-36
Evans, T.	Insp., S. Lancs	Chief Insp., S. Lancs	7-10-36
Dennison, R. T. A.	Insp., E-in-C.O.	Chief Insp., E-in-C.O.	22-11-36
Treglown, P. G.	Insp., S. Western	Chief Insp., S. Western	13-10-36
Harrold, E. J.	Insp., E-in-C.O.	Chief Insp., E-in-C.O.	4-11-36
Claxton, H. L.	Insp., E-in-C.O.	Chief Insp., E-in-C.O.	4-11-36
Wilcox, A.	Insp., E-in-C.O.	Chief Insp., E-in-C.O.	4-11-36
Palk, E.	Insp., E-in-C.O.	Chief Insp., E-in-C.O.	4-11-36
Edwards, W. K.	Insp., Scot. Reg.	Chief Insp., Scot. Reg.	1-11-36
Rimes, R. E.	Insp., E-in-C.O.	Chief Insp., E-in-C.O.	1-10-36
Smith, E. R.	Insp., E-in-C.O.	Chief Insp., E-in-C.O.	10-5-36
Thomas, G. E. T.	Insp., E-in-C.O.	Chief Insp., E-in-C.O.	25-9-36
Smith, W.	Mech.-in-Charge, Gr. I, Plymouth	Tech. Asst., Nottingham	10-1-37
Kirk, J. H.	S.W.I., S. Lancs	Insp., S. Lancs	6-8-36
Adlington, J.	S.W.I., N. Wales	Insp., N. Wales	20-1-36
Attenborough, C. E.	S.W.I., N. Wales	Insp., N. Wales	17-12-36
Beet, H. D.	S.W.I., N. Wales	Insp., N. Wales	22-11-36
Cooper, N. A.	S.W.I., N. Wales	Insp., N. Wales	28-11-36
Dutton, J. A.	S.W.I., N. Wales	Insp., N. Wales	19-12-36
Ferneyhough, J. B.	S.W.I., N. Wales	Insp., N. Wales	1-7-36
Goodwin, T. L.	S.W.I., N. Wales	Insp., N. Wales	6-8-36
Halliday, C. L.	S.W.I., N. Wales	Insp., N. Wales	21-6-36
Harden, P.	S.W.I., N. Wales	Insp., N. Wales	22-3-36
Hinton, H.	S.W.I., N. Wales	Insp., N. Wales	15-8-36
Hunt, A. A.	S.W.I., N. Wales	Insp., N. Wales	19-11-35
Jarvis, R.	S.W.I., N. Wales	Insp., N. Wales	26-9-36
Mainwaring, G.	S.W.I., N. Wales	Insp., N. Wales	26-4-36
Matthews, G. T. H.	S.W.I., N. Wales	Insp., N. Wales	29-12-35
Newey, L. G. B.	S.W.I., N. Wales	Insp., N. Wales	26-4-36
Roberts, A.	S.W.I., N. Wales	Insp., N. Wales	26-12-36
Roberts, E. W.	S.W.I., N. Wales	Insp., N. Wales	17-5-36
Simpson, E.	S.W.I., N. Wales	Insp., N. Wales	24-5-36
Smith, H. B.	S.W.I., N. Wales	Insp., N. Wales	1-7-36
Todd, H. F.	S.W.I., N. Wales	Insp., N. Wales	1-11-36
Whitehouse, A. H.	S.W.I., N. Wales	Insp., N. Wales	1-3-36
Williams, E.	S.W.I., N. Wales	Insp., N. Wales	7-12-36
Clarkson, W. H.	S.W.I., N. Western	Insp., N. Western	30-12-36
Finney, P.	S.W.I., N. Western	Insp., N. Western	19-12-36
Burgess, C. L.	S.W.I., S. Western	Insp., S. Western	3-1-37
Goulbourn, R.	S.W.I., S. Lancs	Insp., S. Lancs	18-10-36
Hyman, H. L.	S.W.I., N. Midland	Insp., N. Midland	8-11-36
Pickworth, G. L.	S.W.I., Eastern	Insp., E-in-C.O.	9-1-37
Stears, A. D. S.	S.W.I., Cupar R. Stn.	Insp., Baldock R. Stn.	5-12-36
Blaikie, J. H.	S.W.I., Scot. Reg.	Insp., Scot. Reg.	12-10-36
Hutchison, J. S.	S.W.I., Scot. Reg.	Insp., Scot. Reg.	16-10-36
Fruish, J.	S.W.I., Scot. Reg.	Insp., Scot. Reg.	5-1-37
Walker, T.	S.W.I., Scot. Reg.	Insp., Scot. Reg.	8-11-36

PROMOTIONS—continued.

Name	From	To	Date
Whyte, W. J.	S.W.I., Scot. Reg.	Insp., Scot. Reg.	10-1-37
Ritchie, W. H.	S.W.I., Scot. Reg.	Insp., Scot. Reg.	23-2-36
McLean, A.	S.W.I., Scot. Reg.	Insp., Scot. Reg.	23-12-36
Jardine, C. T.	S.W.I., Scot. Reg.	Insp., Scot. Reg.	22-3-36
McGregor, J. R.	S.W.I., Scot. Reg.	Insp., Scot. Reg.	19-11-36
Fazacherley, H.	S.W.I., N. Western	Insp., N. Western	7-2-37
Suggett, J. W. H.	S.W.I., N. Western	Insp., N. Western	23-8-36
Baker, H.	S.W.I., E.-in-C.O.	Insp., E.-in-C.O.	25-11-36
Bentley, W. C. B.	S.W.I., E.-in-C.O.	Insp., E.-in-C.O.	30-8-36
Bristow, W. T.	S.W.I., E.-in-C.O.	Insp., E.-in-C.O.	28-6-36
Burgess, A. E.	S.W.I., E.-in-C.O.	Insp., E.-in-C.O.	27-9-36
Cannell, J. A.	S.W.I., E.-in-C.O.	Insp., E.-in-C.O.	20-9-36
Greenaway, C. R.	S.W.I., E.-in-C.O.	Insp., E.-in-C.O.	30-8-36
Laurence, C.	S.W.I., E.-in-C.O.	Insp., E.-in-C.O.	24-10-36
Milam, A. E. E.	S.W.I., E.-in-C.O.	Insp., E.-in-C.O.	13-8-36
Paterson, J.	S.W.I., E.-in-C.O.	Insp., E.-in-C.O.	15-8-36
Pollard, A. J.	S.W.I., E.-in-C.O.	Insp., E.-in-C.O.	11-10-36
Rivis, J. W.	S.W.I., E.-in-C.O.	Insp., E.-in-C.O.	1-4-36
Smith, L.	S.W.I., E.-in-C.O.	Insp., E.-in-C.O.	7-6-36
Soar, W. D.	S.W.I., E.-in-C.O.	Insp., E.-in-C.O.	27-9-36
Stevens, H. E.	S.W.I., E.-in-C.O.	Insp., E.-in-C.O.	10-5-36
Thornton, F. R.	S.W.I., E.-in-C.O.	Insp., E.-in-C.O.	10-2-37
Walton, J. M.	S.W.I., E.-in-C.O.	Insp., E.-in-C.O.	19-6-36
White, E. M.	S.W.I., E.-in-C.O.	Insp., E.-in-C.O.	28-2-37
Cooper, E. B.	S.W.I., N. Midland	Insp., E.-in-C.O.	5-9-36
Dean, J. E.	S.W.I., London	Insp., E.-in-C.O.	31-10-36
Foskett, G. E.	S.W.I., London	Insp., E.-in-C.O.	8-11-36
Fradley, W.	S.W.I., S. Lancs	Insp., E.-in-C.O.	24-9-36
Manning, G. A.	S.W.I., N. Western	Insp., E.-in-C.O.	2-1-37
Parker, W. J.	S.W.I., London	Insp., E.-in-C.O.	12-12-36
Scotcher, W. H.	S.W.I., London	Insp., E.-in-C.O.	16-5-36
Worthington, D. C.	S.W.I., London	Insp., E.-in-C.O.	31-10-36
Rowlands, E. J.	S.W.I., S. Lancs	Insp., E.-in-C.O.	9-1-37
Wilson, A. E. T.	S.W.I., N. Western	Insp., E.-in-C.O.	23-1-37
Peters, B.	S.W.I., St. Albans R. Stn.	Insp., E.-in-C.O.	9-1-37
Hodgkinson, A. A. A.	S.W.I., N.E. Reg.	Insp., E.-in-C.O.	9-1-37
Wallace, A.	S.W.I., N.E. Reg.	Insp., E.-in-C.O.	24-10-36
Beeby, A. V.	S.W.I., N. Midland	Insp., N. Midland	30-7-36
Brealey, E. C.	S.W.I., N. Midland	Insp., N. Midland	3-1-37
Richards, P. W.	S.W.I., N. Midland	Insp., N. Midland	1-2-37
Crabb, G. T.	S.W.I., S. Lancs	Insp., S. Lancs	18-10-36
Traynor, W. S.	S.W.I., S. Lancs	Insp., S. Lancs	23-10-36
Huxley, G. F.	S.W.I., S. Lancs	Insp., S. Lancs	1-10-36
O'Connor, H.	S.W.I., Scot. Reg.	Insp., Scot. Reg.	26-7-36
Devan, H.	S.W.I., Scot. Reg.	Insp., Scot. Reg.	12-9-36
McPhail, A.	S.W.I., Scot. Reg.	Insp., Scot. Reg.	5-1-37
McLeod, N.	S.W.I., Scot. Reg.	Insp., Scot. Reg.	16-10-36
Bissett, W. T.	S.W.I., Scot. Reg.	Insp., Scot. Reg.	6-4-36
McGregor, J. H.	S.W.I., Scot. Reg.	Insp., Scot. Reg.	28-12-36
McDougall, R. S.	S.W.I., Scot. Reg.	Insp., Scot. Reg.	22-11-36
McMillan, R. S.	S.W.I., Scot. Reg.	Insp., Scot. Reg.	8-11-36
Haines, J. P.	S.W.I., Scot. Reg.	Insp., Scot. Reg.	4-1-37
Failes, W. J.	S.W.I., Scot. Reg.	Insp., Scot. Reg.	23-2-36
Gordon, W. J.	S.W.I., Scot. Reg.	Insp., Scot. Reg.	22-11-36
Keith, E.	S.W.I., Scot. Reg.	Insp., Scot. Reg.	16-10-36
Calderwood, R.	S.W.I., Scot. Reg.	Insp., Scot. Reg.	19-11-36
Brown, J.	S.W.I., Scot. Reg.	Insp., Scot. Reg.	16-10-36
Stewart, H.	S.W.I., Scot. Reg.	Insp., Scot. Reg.	12-9-36
Cameron, H. A.	S.W.I., Scot. Reg.	Insp., Scot. Reg.	12-9-36
McIndoe, T.	S.W.I., Scot. Reg.	Insp., Scot. Reg.	12-9-36
Fraser, W.	S.W.I., Scot. Reg.	Insp., Scot. Reg.	16-11-36
Smellie, D. M.	S.W.I., Scot. Reg.	Insp., Scot. Reg.	23-2-36
McBeth, H. A.	S.W.I., Scot. Reg.	Insp., Scot. Reg.	20-12-36
Turner, A. G.	S.W.I., Scot. Reg.	Insp., Scot. Reg.	30-11-36
McGovern, M. P. P.	S.W.I., Scot. Reg.	Insp., Scot. Reg.	25-2-36
Quinn, F.	S.W.I., Scot. Reg.	Insp., Scot. Reg.	25-2-36
Malcolm, W. A. S.	S.W.I., Scot. Reg.	Insp., Scot. Reg.	26-2-36
Williamson, F. R.	S.W.I., Scot. Reg.	Insp., Scot. Reg.	23-3-36
McLeod, J.	S.W.I., Scot. Reg.	Insp., Scot. Reg.	24-8-36
Thomson, G. M.	S.W.I., Scot. Reg.	Insp., Scot. Reg.	26-12-36
Allen, R. A.	S.W.I., S. Midland	Insp., S. Midland	1-7-36
Marks, T. A.	S.W.I., S. Midland	Insp., S. Midland	1-7-36
Rowell, P. C.	S.W.I., S. Midland	Insp., S. Midland	27-12-36
Stone, W. C.	S.W.I., S. Midland	Insp., S. Midland	12-12-36
Welburn, R.	S.W.I., S. Midland	Insp., S. Midland	7-2-37
Birkenshaw, T.	S.W.I., N.E. Reg.	Insp., N.E. Reg.	10-1-37

PROMOTIONS—continued.

Name	From	To	Date
Rushworth, M.	S.W.I., N.E. Reg.	Insp., N.E. Reg.	10-1-37
Hall, V.	S.W.I., N.E. Reg.	Insp., N.E. Reg.	17-1-37
Simpson, H.	S.W.I., N.E. Reg.	Insp., N.E. Reg.	17-1-37
Batchelor, W.	S.W.I., Scot. Reg.	Insp., Scot. Reg.	16-10-36
Jeacock, F. A.	S.W.I., N. Midland	Insp., N. Midland	23-9-36
Bell, R. J. B.	S.W.I., Eastern	Insp., Eastern	To be fixed later.
Billman, B. C.	S.W.I., Eastern	Insp., Eastern	To be fixed later.
Browne, J. E.	S.W.I., Eastern	Insp., Eastern	To be fixed later.
Dann, J. V.	S.W.I., Eastern	Insp., Eastern	To be fixed later.
Hartley, A. J.	S.W.I., Eastern	Insp., Eastern	To be fixed later.
Loome, T. H.	S.W.I., Eastern	Insp., Eastern	To be fixed later.
Parker, C. E. H.	S.W.I., Eastern	Insp., Eastern	To be fixed later.
Keeve, C. W.	S.W.I., Eastern	Insp., Eastern	To be fixed later.
Self, G. A.	S.W.I., Eastern	Insp., Eastern	To be fixed later.
Stearn, A. J. L.	S.W.I., Eastern	Insp., Eastern	To be fixed later.
Turner, E. J. V.	S.W.I., Eastern	Insp., Eastern	To be fixed later.
Babridge, R. E.	S.W.I., S. Western	Insp., S. Western	To be fixed later.
Brewer, W. E.	S.W.I., S. Western	Insp., S. Western	To be fixed later.
Brock, S.	S.W.I., S. Western	Insp., S. Western	To be fixed later.
Cohu, M.	S.W.I., S. Western	Insp., S. Western	To be fixed later.
Crossing, R. G.	S.W.I., S. Western	Insp., S. Western	To be fixed later.
Dennett, E. H. Y.	S.W.I., S. Western	Insp., S. Western	To be fixed later.
Harfoot, T. R.	S.W.I., S. Western	Insp., S. Western	To be fixed later.
Jones, S.	S.W.I., S. Western	Insp., S. Western	To be fixed later.
O'Brien, E. J.	S.W.I., S. Western	Insp., S. Western	To be fixed later.
Paul, W. C.	S.W.I., S. Western	Insp., S. Western	To be fixed later.
Piggott, T. W.	S.W.I., S. Western	Insp., S. Western	To be fixed later.
Smith, E. H.	S.W.I., S. Western	Insp., S. Western	To be fixed later.
Spencer, H. H.	S.W.I., S. Western	Insp., S. Western	To be fixed later.
Webb, C. D.	S.W.I., S. Western	Insp., S. Western	To be fixed later.
Williams, N. P.	S.W.I., S. Western	Insp., S. Western	To be fixed later.
Parker, J.	S.W.I., S. Lancs	Insp., S. Lancs	To be fixed later.
Proctor, R.	S.W.I., S. Lancs	Insp., S. Lancs	To be fixed later.
Marsland, J. P.	S.W.I., S. Lancs	Insp., S. Lancs	To be fixed later.
Phillips, C.	S.W.I., S. Lancs	Insp., S. Lancs	To be fixed later.
Banham, S. H.	S.W.I., Test Section, London	Insp., Test Section, London	To be fixed later.
Harris, H. B.	S.W.I., Test Section, London	Insp., Test Section, London	To be fixed later.
Marks, S. J.	S.W.II., N. Wales	Insp., N. Wales	6-8-36
Pawlby, R. L.	Draughtsman II., S. Western	Draughtsman I., S. Western	11-11-36
Fibbitts, J. E.	Draughtsman II., S. Western	Draughtsman I., S. Western	11-11-36
Simmons, F. G.	Draughtsman II., London	Draughtsman I., S. Eastern	10-1-37
Orchard-Carter, A. W.	Draughtsman II., S. Western	Draughtsman I., S. Western	11-11-36
Culverwell, W. L.	Draughtsman II., S. Wales	Draughtsman I., S. Wales	11-11-36
Walker, T. E.	Draughtsman II., N.E. Reg.	Draughtsman I., N.E. Reg.	1-1-37
Oates, R.	Draughtsman II., N. Wales	Draughtsman I., S. Midland	17-1-37

APPOINTMENT.

Name	From	To	Date
Goodchild, L. F.	Insp., London	Proby. Asst. Engr., London	7-1-37

DEATHS.

Name	Rank	District	Date
Corkett, H.	Asst. Engr.	London	3-12-36
Sheppard, R.	Asst. Engr.	N. Wales	31-1-37
Swindlehurst, R. J. K.	Asst. Engr.	E.-in-C.O.	18-2-37
Cunninghame, R. J. M.	Chief Insp.	N. Wales	9-12-36
Hills, J. A. E.	Chief Insp.	London	30-12-36
Baxter, F.	Chief Insp.	S. Lancs	20-2-37
Flitcroft, J. O.	Insp.	N. West	28-12-36
Clark, J. H.	Draughtsman I.	London	19-12-36
Wimpenny, E. V.	Draughtsman II.	N.E. Reg.	19-12-36

TRANSFERS.

Name	Rank	From	To	Date
Harris, L. H.	A.S.E.	E.-in-C.O.	Eastern	1-2-37
Tamplin, G. R.	Exec. Engr.	S. Wales	S. Western	17-1-37
Taylor, T. A.	Exec. Engr.	S. Wales	E.-in-C.O.	31-1-37
Ingram, C. P.	Asst. Engr.	E.-in-C.O.	Eastern	8-12-36
Affleck, D. B.	Asst. Engr.	E.-in-C.O.	N. Midland	9-1-37
Spears, G.	Asst. Engr.	E.-in-C.O.	Scot. Reg.	21-2-37
Chorley, J. W. A.	Prob. Asst. Engr.	E.-in-C.O. School	S. Lancs	1-1-37
Clarke, A. C. W. V.	Prob. Asst. Engr.	E.-in-C.O. School	London	1-1-37
Cooper, A. B.	Prob. Asst. Engr.	E.-in-C.O. School	E.-in-C.O.	1-1-37
Stevenson, H. C.	Prob. Asst. Engr.	E.-in-C.O. School	Scot. Reg.	1-1-37
Thompson, J. O.	Prob. Asst. Engr.	E.-in-C.O. School	Scot. Reg.	1-1-37
de Courcy, F. J.	Prob. Asst. Engr.	E.-in-C.O. School	N. Ireland	1-1-37
Hanman, B. L. G.	Prob. Asst. Engr.	E.-in-C.O. School	E.-in-C.O.	1-1-37
Hibbs, N. L.	Prob. Asst. Engr.	E.-in-C.O. School	N. Wales	1-1-37
Kilvington, T.	Prob. Asst. Engr.	E.-in-C.O. School	E.-in-C.O.	1-1-37
Lillicrap, H. G.	Prob. Asst. Engr.	E.-in-C.O. School	S. Western	1-1-37
Neate, A. D.	Prob. Asst. Engr.	E.-in-C.O. School	S. Midland	1-1-37
Read, R. A.	Prob. Asst. Engr.	E.-in-C.O. School	N.E. Reg.	1-1-37
Soper, D. C.	Prob. Asst. Engr.	E.-in-C.O. School	E.-in-C.O.	1-1-37
Mew, R. J.	Prob. Asst. Engr.	E.-in-C.O. School	Test Section, London	1-2-37
Turner, A. F.	Prob. Asst. Engr.	N. Wales	E.-in-C.O.	31-1-37
Chorley, J. W. A.	Prob. Asst. Engr.	S. Lancs	E.-in-C.O.	14-2-37
Smith, A. E.	Chief Insp.	S. Wales	S. Midland	3-1-37
Warne, G. C.	Chief Insp.	London	E.-in-C.O.	14-1-37
Lewis, H. C.	Insp.	S. Midland	S. Wales	3-1-37
Dunn, C.	Tech. Asst.	Nottingham	Exeter	24-1-37
Cook, G. H.	Insp.	Rugby R. Stn.	N.E. Reg.	3-1-37
Ade, A. F.	Insp.	Rugby R. Stn.	N. Midland	1-1-37
Rumary, F. J.	Insp.	Portishead R. Stn.	S. Western	14-2-37
Bucklitsch, E. K. F.	Insp.	E.-in-C.O.	S. Western	23-1-37

RETIREMENTS.

Name	Rank	District	Date
Hines, Capt. J. G.	Staff Engr.	E.-in-C.O.	28-2-37
Fletcher, Capt. J. E.	Asst. Suptg. Engr.	N.E. Reg.	20-1-37
Warnock, J. W.	Area Engr.	Scot. Reg.	28-2-37
Stanton, J. D.	Exec. Engr.	E.-in-C.O.	17-2-37
Buchanan, J.	Exec. Engr.	N. Western	31-12-36
Cory, B. G.	Asst. Engr.	S. Wales	23-2-37
Keir, A. D.	Asst. Engr.	Scot. Reg.	2-2-37
Kirkwood, D.	Asst. Engr.	S. Western	31-12-36
Smith, F. M.	Asst. Engr.	N. Midland	31-12-36
Lloyd, H. P.	Asst. Engr.	N. Wales	31-12-36
Woods, E. J.	Asst. Engr.	E.-in-C.O.	31-12-36
Rathbone, E. J.	Asst. Engr.	E.-in-C.O.	31-12-36
Chambers, R. A. G.	Chief Insp.	N. Western	31-12-36
Saltmarsh, N. A.	Chief Insp.	N. Midland	31-12-36
Geisler, G. C.	Chief Insp.	London	31-1-37
Spicer, F.	Chief Insp.	London	31-1-37
Fawcett, T. W.	Insp.	London	17-12-36
Holman, R. H.	Insp.	London	31-12-36
Applegate, C. J.	Insp.	London	1-1-37
Blasson, C. A.	Insp.	N. Western	31-1-37
Butcher, C. F.	Insp.	Eastern	31-12-36
Huson, W. T.	Insp.	S. Western	31-12-36
Williams, C.	Insp.	S. Lancs	31-12-36
Wynne, T. H.	Insp.	London	31-1-37
Burn, T.	Insp.	Scot. Reg.	31-12-36
Spray, F. J.	Insp.	S. Western	18-1-37
Falshaw, P. E.	Insp.	London	5-3-37
Utting, W. A.	Insp.	S. Lancs	16-3-37
Trist, W. E.	Insp.	S. Eastern	17-12-36

CLERICAL GRADES

PROMOTIONS.

Name	From	To	Date
Suttle, E. C.	Staff Officer, E.-in-C.O.	Assistant Inspector of Clerical Establishments, Headquarters	18-2-37
Jones, F. E.	H.C.O., S. Western	Staff Officer, S. Western	1-2-37
Halsall, T. P.	H.C.O., N. Western	Actg. Staff Officer, S. Lancs	1-2-37
McBrien, T. B.	C.O., N. Ireland	Actg. H.C.O., N. Ireland	27-12-36
Gulland, G. W. I. St. C.	C.O., N. Western	Actg. H.C.O., N. Western	18-2-37
Brewer, T. D.	C.O., E.-in-C.O.	Actg. Exec. Officer, E.-in-C.O.	21-12-36

RETIREMENTS.

Name	Rank	District	Date
Jones, J. W.	Staff Officer	S. Lancs	31-1-37
Williams, D.	Staff Officer	S. Western	31-1-37
Wood, G.	C.O.	E.-in-C.O.	31-12-36
Powis, G. E.	C.O.	N. Wales	31-12-36
MacMullen, H.	C.O.	London	22-2-37
Johnstone, A. G.	C.O.	London	21-2-37
Fox, W. T.	C.O.	S. Eastern	6-2-37
Davies, A. A.	C.O.	S. Midland	4-3-37

DEATHS.

Name	Rank	District	Date
Yates, F. N. L.	C.O.	S. Lancs	30-11-36

TRANSFERS.

Name	Rank	From	To	Date
Barrow, J. F.	C.O.	Eastern	Ministry of Transport	7-2-37

BOARD OF EDITORS

B.O. ANSON, M.I.E.E., Chairman.

A. J. GILL, B.Sc., M.I.E.E., M.I.R.E.

G. F. O'DELL, B.Sc., M.I.E.E.

F. E. NANCARROW, A.R.C.Sc., M.I.E.E., M.I.R.E.

H. CARTER, T.D., B.Sc., A.R.C.Sc., M.I.E.E.

J. STRATTON, A.M.I.E.E.

J. READING, B.Sc.(Eng.), A.M.I.E.E., Managing Editor.

H. LEIGH, B.Sc.(Eng.), A.M.I.E.E., Assistant Editor.

Copyright

The entire contents of this Journal are covered by general copyright, and special permission is necessary for reprinting long extracts, but Editors are welcome to use not more than one-third of any article, provided credit is given at the beginning or end thus: "From the *Post Office Electrical Engineers' Journal*."

The Board of Editors is not responsible for the statements made or the opinions expressed in any of the articles in this Journal, unless such statement is made specifically by the Board.

Communications

All Communications should be addressed to the Managing Editor, *P.O.E.E. Journal*, Engineer-in-Chief's Office, Alder House, Aldersgate Street, London, E.C.1. Telephone: NATIONAL 6321. Remittances should be made payable to "The *P.O.E.E. Journal*" and should be crossed "& Co."

Binding Cases

Binding cases are available, and may be obtained from the Local Agents for 1s. 9d. Subscribers can have their copies of Volumes bound, at a cost of 3s., by sending the complete sets of parts to the Local Agents or to the Publishers. Orders for binding for Vols. 1-19 should indicate whether the original binding case with black lettering, or the later pattern with gold, is required. Cases with gold lettering will be the only type stocked from Vol. 20 onwards.

Back Numbers

The price of the Journal, which is published quarterly, is 1s. (1s. 3d. post free) per copy, or 5s. per annum post free. Back numbers can be supplied, subject to availability of stocks, at 1s. each (1s. 3d. post free). Orders for back numbers may be sent to the Local Agents or to the Publishers.

Advertisements

All communications relating to space reservations should be addressed to the Advertisement Editor, *P.O.E.E. Journal*, Alder House, Aldersgate Street, London, E.C.1. Communications regarding advertisement copy, proofs, etc., should be addressed to the Publishers, Messrs. Birch & Whittington (Prop. Dorling & Co. [Epsom], Ltd.), Station Road, Epsom, Surrey.

THE INSTITUTION OF POST OFFICE ELECTRICAL ENGINEERS

PRINTED PAPERS

The following papers contributed to the proceedings of the Institution have been printed by authority of the Council and may be obtained, if still in print, from

"THE LIBRARIAN, The Institution of Post Office Electrical Engineers, G.P.O. (ALDER HOUSE), LONDON, E.C.1."

The prices do *not* include postage, and in every case, Members, Associate Members, and Associates have the privilege of purchasing copies at two-thirds the stated price.

No. 92	"TELEPHONE METERS AND COIN COLLECTING BOXES."—W. CRUICKSHANK, M.I.E.E., and F. McCLARENCE, M.I.E.E. 1923	1s.
No. 108	"SOME APPLICATIONS OF OPTICAL METHODS TO THE EXAMINATION OF ENGINEERING MATERIALS."—F. O. BARRALET, M.Inst.Metals, A.M.I.E.E. 1925	1s.
No. 109	"THE PROBLEM OF FLEXIBILITY IN SUBSCRIBERS' CABLE DISTRIBUTION."—HARVEY SMITH. 1925	1s.
No. 110	"TESTING OF TELEPHONE CIRCUITS AND APPARATUS WITH ALTERNATING CURRENTS."—E. S. RITTER, D.F.H., A.M.I.E.E., and G. P. MILTON. 1926	1s. 3d.
No. 111	"SCIENTIFIC ORGANISATION AND THE POST OFFICE ENGINEERING DEPARTMENT."—F. G. C. BALDWIN, M.I.E.E. 1926	1s.
No. 116	"THE DIRECTOR IN AUTOMATIC TELEPHONY."—C. W. BROWN, A.M.I.E.E. 1927	9d.
No. 117	"THE SUBMARINE LINK IN INTERNATIONAL TELEPHONY."—C. ROBINSON, B.A., A.M.I.E.E. 1928.	1s.
No. 119	"THE PROBLEM OF THE P.B.X. CONNECTED TO AN AUTOMATIC EXCHANGE."—C. W. BROWN, A.M.I.E.E., and R. J. HINES, B.Sc. 1928	9d.
No. 120	"SATELLITE EXCHANGES IN AUTOMATIC AREAS."—F. I. RAY, B.Sc., D.F.H., A.M.I.E.E. 1927	1s.
No. 121	"X-RAYS, AND THE STRUCTURE OF SOME ENGINEERING MATERIALS."—W. G. RADLEY, B.Sc. 1929	9d.
No. 122	"THE MEASUREMENT OF RELAY TIMES."—R. W. PALMER, A.M.I.E.E. 1929	9d.
No. 123	"MODERN ELECTRICAL ILLUMINATION."—J. J. EDWARDS, B.Sc.(Eng.), A.C.G.I., D.I.C. 1928	9d.
No. 124	"THE MEASUREMENT OF SOUND AND ITS APPLICATION TO TELEPHONY."—A. J. ALDRIDGE, A.C.G.I., A.M.I.E.E. 1929	9d.
No. 125	"THE DEVELOPMENT OF AUTOMATIC ROUTINERS IN THE BRITISH POST OFFICE."—A. SPEIGHT, A.M.I.E.E. 1929.	9d.
No. 134	"SOUND AND HEARING."—Capt. N. F. CAVE-BROWNE-CAVE, B.Sc., M.I.E.E. 1930	1s.
No. 136	"SOME DEVELOPMENTS IN TELEGRAPH TECHNIQUE AS APPLIED TO RADIO CIRCUITS."—H. FAULKNER, B.Sc., A.M.I.E.E., and G. T. EVANS. 1931.	1s.
No. 140	"SOME NON-METALLIC SUBSTANCES AND THEIR CHARACTERISTICS."—Capt. N. F. CAVE-BROWNE-CAVE, B.Sc., A.M.I.E.E. 1931.	9d.
No. 142	"PRIVATE BRANCH EXCHANGE INSTALLATIONS."—R. T. A. DENNISON. 1932.	1s. 3d.
No. 143	"ELECTRIC WAVE FILTERS."—G. J. S. LITTLE, B.Sc. 1931	1s. 3d.
No. 146	"LAYING ARMoured CABLE BY MEANS OF A MOLE-DRAINER."—L. G. SEMPLE, B.Sc.(Eng.), and R. O. BOCCOCK, B.Sc.(Eng.). 1932.	9d.
No. 147	"DESIGN AND CONSTRUCTION OF ELECTRIC WAVE FILTERS."—R. J. HALSEY, B.Sc., etc. 1932.	1s. 3d.
No. 148	"STORES SPECIFICATIONS AND ACCEPTANCE TESTING."—CAPT. J. LEGG, B.Sc., A.M.I.E.E. 1933	9d.
No. 149	"RECENT DEVELOPMENTS IN UNDERGROUND CONSTRUCTION, LAYING AND LOADING ARMoured CABLES."—J. E. Z. BRYDEN, B.Sc.(Eng.), A.M.I.E.E., and T. HARGREAVES, A.M.I.E.E. 1933	1s.
No. 150	"TELEPRINTERS."—E. S. RITTER, M.I.E.E. 1933	1s.
No. 151	"RECENT REPEATER STATION INSTALLATIONS."—Major F. E. A. MANNING, M.C., B.Sc.(Eng.), M.I.E.E., A.M.I.Mech.E. 1933	1s.
No. 152	"SOME NOTES ON EXCHANGE EQUIPMENT FACTORY COSTING AND THE ECONOMICS OF PRODUCTION."—S. J. HUSBAND, ASSOC.I.E.E. 1933	1s. 3d.
No. 153	"MODERN DEVELOPMENTS IN TELEPHONE TRANSMISSION OVER WIRELINES."—J. STRATTON, A.C.G.F.C., and W. G. LUXTON. 1933	1s. 3d.
No. 154	"THE TELEGRAPH POLE."—W. H. BRENT, B.Sc., A.M.I.E.E. 1933	1s.
No. 156	"MODERN TENDENCIES IN THE SUPPLY OF POWER TO TELEPHONE EXCHANGES."—H. C. JONES, B.Sc.(Eng.). 1935	9d.
No. 157	"RECENT ADVANCES IN CARRIER TELEPHONY."—R. J. HALSEY, B.Sc.(Hons.), A.C.G.I., D.I.C. 1935	1s. 3d.
No. 158	"ULTRA SHORT WAVE RADIO TELEPHONE CIRCUITS."—D. A. THORN, B.Sc.(Eng.), A.M.I.E.E., and H. T. MITCHELL, A.M.I.E.E. 1935	1s.
No. 159	"MODERN ELECTRIC PASSENGER LIFTS."—R. S. PHILLIPS, A.M.I.E.E. 1935	9d.

**EMPLOY WESTON LABORATORY
STANDARDS AND PLACE YOUR
INSTRUMENTS ABOVE CRITICISM**

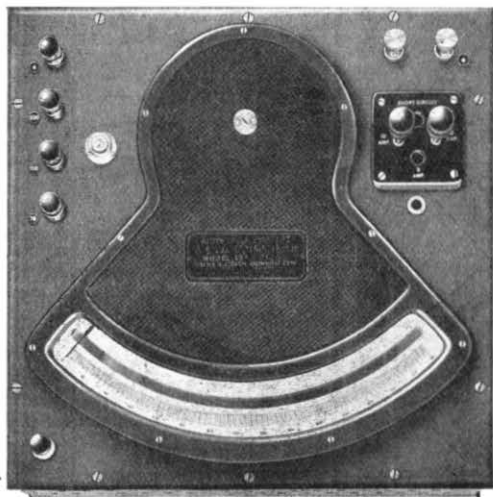

WESTON MODEL 326

The WESTON Model 326—universally respected for its lasting dependability—is an old friend among leading engineers. (*Confirm this by asking your friends who use them. Weston will supply a list on request.*)

Now is the time to acquire this instrument, and in years to come you will realize the soundness of your judgment.

- 12-inch scale—accurate within 1/10% or better.
- Equally accurate on D.C. or A.C. of any wave form or any power factor (an admirable transfer standard).
- Compensated over a wide range of temperatures.
- 2 current ranges, which may be overloaded 100% continuously—without loss of accuracy (virtually 3 current ranges).
- 3 potential ranges covering all usual needs.

WESTON
"Standard the World over"
PIONEERS SINCE 1880

Advt. of the Weston Electrical Instrument Co., Ltd.,
Kingston By-pass, Surbiton, Surrey. (Elmbridge 6400)

**DIRECT READING
CAPACITANCE BRIDGE**

RANGE 1 $\mu\mu\text{F}$ to 100 μF

ACCURACY 0.2 % THROUGHOUT

Scale accuracy 0.1 %

A recently developed alternating current bridge of entirely novel design which gives the unique feature of uniform scale accuracy throughout an extremely wide range of capacitance measurements. The novelty of principle is in the main that of combining the use of a truly logarithmic standard of capacitance with multiplying ratio arms.

Thus there is only one calibrated standard, and this is calibrated with high accuracy at a large number of cardinal capacitances and closely and accurately subdivided. The scale of this standard is engraved direct in capacitance from 0 to 1,200 $\mu\mu\text{F}$, and a simple rotary switch is operated to multiply the scale reading by multiples of 10.

**AURAL OR VISUAL
INDICATION OF BALANCE**

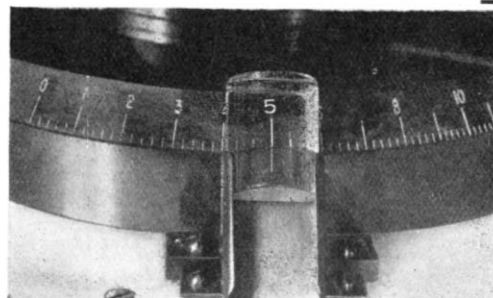

Illustrating the great openness of scale and the simple magnifier employed on this bridge to facilitate rapid reading with accuracy.

**Full particulars of this and other
bridges of higher or lower
accuracies on application.**

H. W. SULLIVAN LIMITED

TELEPHONES :
NEW CROSS 2911 (3 LINES)

LONDON, S.E.15

TELEGRAPHIC ADDRESS :
" STANDELECT, PECK, LONDON "

"Sullivan" guarantees accuracy

G.E.C.

ELECTRICAL INSTRUMENTS

for all purposes

MADE AT THE SALFORD ELECTRICAL INSTRUMENT WORKS

The most exacting standards of accuracy and reliability are established at these works, where so many of the finest instruments used in research and industry are made.

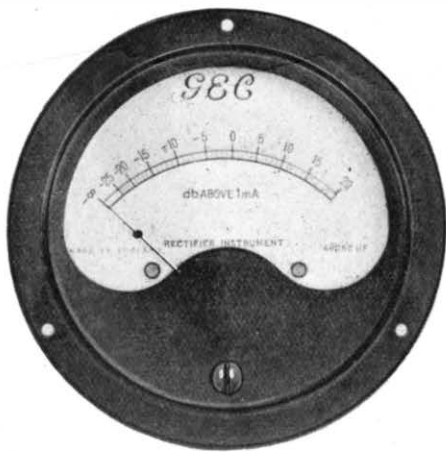

DECIBEL METERS
20-15,000 cycles per sec.

Robust construction and fine finish are also distinctive features of all G.E.C. instruments.

ENQUIRIES ARE WELCOMED FOR
INSTRUMENTS OF ALL TYPES
INCLUDING
THOSE FOR SPECIAL PURPOSES

Full particulars of the range of Decibel Meters are given in leaflet No. S.18

Made at The Salford Electric Instrument Works of

THE GENERAL ELECTRIC CO. LTD.
Head Office: MAGNET HOUSE, KINGSWAY, LONDON, W.C.2
Branches throughout Great Britain and in all the principal markets of the World

NEW

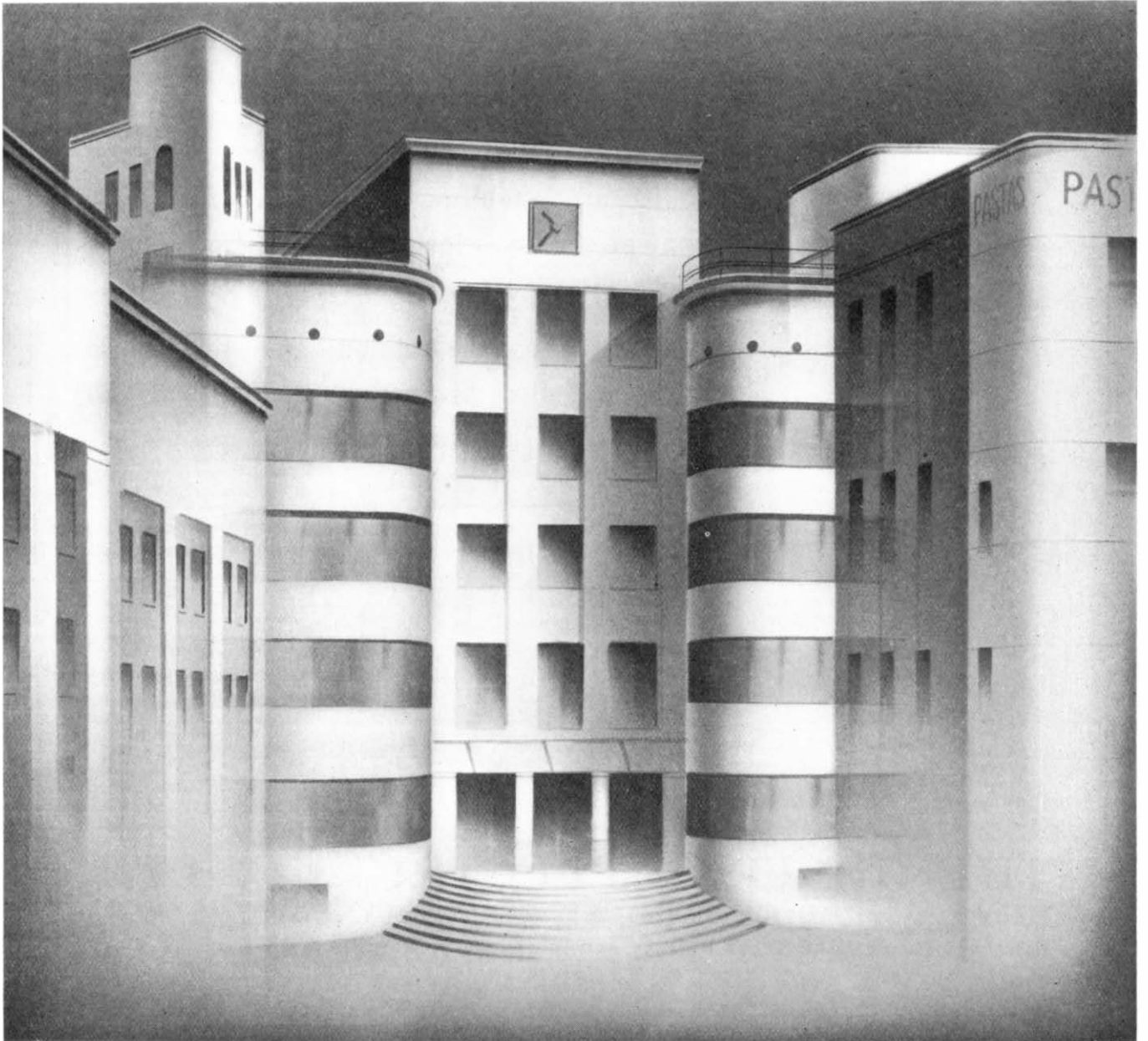

YET HISTORIC

Strowger in the progress of a Nation

From the aftermath of the Great War, Lithuania, tree-clad country of legend and knightly story, emerged once again a self-governing nation. Rehabilitation of public services and national resources followed as rapidly as circumstances permitted. Telephone communications received the special attention which their importance warranted, and Strowger automatic telephone equipment was chosen to aid in this romantic task of rebuilding a nation.

Klaipeda exchange, with an initial equipment of 3,000 lines and an ultimate capacity of 7,000 lines, was placed in service some twelve months ago, and now Kaunas area also enjoys Strowger service. Kaunas Main exchange contains equipment for 7,500 lines, increasing to 10,000 lines, and accommodation for a further 10,000 lines, while Sanciai satellite caters for 700 subscribers initially with capacity for 1,500 subscribers ultimately. The development and progress of Lithuania, allied with the advantages of Strowger service, will make telephone growth rapid. Every provision has therefore been made in engineering the scheme to facilitate the installation of the second 10,000 line unit and other satellite exchanges.

AUTOMATIC TELEPHONE & ELECTRIC · CO · LTD

MELBOURNE HOUSE, ALDWYCH, LONDON, W.C.2
Telephone No.: Temple Bar 4506 Telegraphic Address: "Strowger Estrand," London.

STROWGER WORKS, LIVERPOOL, 7
Telephone No.: Old Swan 830. Telegraphic Address: "Strowger," Liverpool.



THE STROWGER DIAL ROTATES WITH THE WORLD



INDEX TO ADVERTISERS

Alton Battery Co., Ltd., The	xvi	McGraw-Hill Publishing Co., Ltd.	xxv
Asbestos Cement Co., Ltd.	xix	Marconi-E.M.I. Television Co., Ltd.	xiii
Automatic Telephone & Electric Co., Ltd.	xxii & xxiii	Muirhead & Co., Ltd.	iv
Bennett College	xvii	Pirelli-General Cable Works, Ltd.	xxvi
British Electric Resistance Co., Ltd.	ix	Pitman, Sir Isaac	ix
British Institute of Engineering Technology	xxv	Siemens Bros. & Co., Ltd.	vi & vii
Creed & Co.	viii	Smith, Frederick & Co.	xxvii
Ebonestos Insulators, Ltd.	xxiv	Standard Telephones & Cables, Ltd.	v & viii
Elliott Bros.	xxvii	Sullivan, H. W., Ltd.	xx
Ericsson Telephones, Ltd.	x & xi	Telephony Publishing Corporation	xiv
Evershed & Vignoles, Ltd.	xiv	Triplex	xxiv
Ferranti, Ltd.	xxvi	Tungstone Accumulator Co., Ltd.	ii
General Electric Co., The	iii & xxi	Turner, Ernest	iv
Hall Telephone Accessories (1928), Ltd.	xii	Westinghouse Brake & Signal Co., Ltd.	xv
Ilford, Ltd.	viii	Weston Electrical Instrument Co.	xx
Institution of Post Office Electrical Engineers, The	xxvi		

Fit

"TripleX"
Regd

- and be safe

THE
G.P.O.
DO

THE "TRIPLEX" SAFETY GLASS CO. LTD.,
1 ALBEMARLE STREET · LONDON · W.1

**Moulders to
the Trade**

**...since
1899**

**MOULDINGS
IN WHITE OR
COLOURS.
BAKELITE —
UREA
DIAKON
AND OTHER
SYNTHETICS**

PLASTIC MOULDINGS HAVING
HEAT — ACID — OIL — ALKALI —
WATER RESISTING QUALITIES.

EBONESTOS INDUSTRIES LTD
Excelsior Works,
Rollins Street,
Canterbury Road,

Telephone

NEW CROSS 1913 (5 lines)

LONDON. S.E. 15.

Branch Factory : BARRY RD., STONEBRIDGE PARK, N.W. 10

**PREPARE
FOR
PROGRESS
AND
ADVANCEMENT**



Why do some doctors command a larger and more lucrative practice than others? Because they keep on studying, doing research work and posting themselves on all developments in the medical profession. In short, they make themselves of greater value to their patients by keeping up to date. The same is possible in industry. For example, the man who wants to get ahead in the telephone industry makes it a habit to read TELEPHONY regularly every week. The new series of articles by H. H. Harrison, M.Eng.M.I.E.E., well known throughout Europe, is alone worth the subscription price—\$5.00 U.S. money, for 52 interesting, instructive and inspiring issues.

TELEPHONY

Address : Odhams Press Ltd., Technical Book Dept., 85 Long Acre, London, W.C.2
(Phone : Temple Bar 2468), for a sample copy of TELEPHONY, or write direct to :
TELEPHONY PUBLISHING CORPORATION, 608 S. Dearborn Street, Chicago,
Ill., U.S.A.

*New Second Edition--
Now Ready*

COMMUNICATION ENGINEERING

By WILLIAM L. EVERITT
*Professor of Electrical Engineering
The Ohio State University*

727 pages 9 × 6 Illustrated 30/- net

As in the first edition of this successful book, which was adopted by more than sixty colleges and universities, the author presents a thorough, up-to-date treatment of communication fundamentals. The book provides a balanced course stressing broad principles rather than specific applications.

The new edition represents a thorough revision. Most of the book has been rewritten, and all of it has been brought completely up to date. In addition, the revision offers much new material, including :

1. A new chapter on equalizers. This subject is of growing importance in all types of communication, and the method of attack can be applied to numerous problems of network synthesis.
2. The chapter on electromagnetic coupling has been entirely rewritten to show the use of mechanical impedance methods of analyzing vibrating systems. A general method of analyzing loudspeakers, microphones and telephone receivers is demonstrated.
3. The chapters on radio frequency amplifiers has been entirely rewritten. The treatment of Class B and Class C amplifiers is unique and includes material not previously presented in the literature.
4. The chapters on modulation and detection have been considerably revised to include the effects which occur in amplifiers, including cross modulation and higher order modulation effects. Frequency and phase modulation are also treated. General principles and solutions of detectors, which will apply to all classes of detectors have been outlined.
5. The chapter on radiation has been extended to include computations of antenna arrays and the propagation of waves over an earth of known conductivity.
6. Every chapter has been enlarged with new material which is of importance to the radio and telephone engineer.

★ We shall be glad to send a copy of this book to any address in the United Kingdom for seven days for examination.

McGraw-Hill Publishing Co., Ltd.
ALDWYCH HOUSE LONDON, W.C.2

LATEST EXAMINATION SUCCESSSES

Since the B.I.E.T. was founded ten years ago, we have specialised in preparing candidates for leading Technical Examinations, and our success may be gauged from the following remarkable results :

FOUR 1st PLACES

In the Probationary Inspectors and Assistant Superintendent of Traffic Examinations held in 1932-1935, B.I.E.T. candidates obtained Four First Places.

FIRST TWO PLACES

In the recent Limited Competition Examination for Assistant Superintendents of Traffic, the candidates placed First and Second on the List of Successes were trained by the B.I.E.T.

145 SUCCESSES

In the Probationary Inspectors and Assistant Superintendents of Traffic Examinations held in 1934 and 1935, 145 B.I.E.T. candidates passed the Examinations.

We teach successfully by correspondence and definitely guarantee—

“ NO PASS—NO FEE ”

You are advised to send for a copy of our General Prospectus “ENGINEERING OPPORTUNITIES.” This Hand-book contains 268 pages of most useful information. It also contains particulars of all leading Engineering Examinations, including

Probationary Inspectors (*Open and Limited Competitions*).
Probationary Assistant Engineers (*Limited Competition*).
Assistant Superintendent of Traffic (*Open and Limited Competitions*).
City and Guilds, Special G.P.O. Examination, I.E.E., B.Sc., A.M.I.C.E., London Matric., etc., etc.

The Hand-book also outlines “up-to-the-minute” courses of Home-Study in *all branches* of Engineering.

Special Courses are offered in **Telegraphy, Manual Telephony, Automatic Telephony, Telephone Transmission, Electrical Technology, Wireless and High Frequency Radio Communication, Alternating Currents, etc., etc.**

Our 268 pages Hand-book should be on your Book-shelf. It will be gladly sent on request, FREE and without obligation. (*Please state subject or Examination of most interest.*)

British Institute of Engineering Technology
369 Shakespeare House,
17, 18 & 19 Stratford Place, Oxford Street,
London, W.1

*Owing to substantial increases in the sales of
The Post Office Electrical Engineers' Journal all*

BACK NUMBERS

*of recent issues, with the exception of
Vol. 29, Part 4 (January, 1937),
have been completely sold out.*

In order to avoid disappointment due to the non-availability of supplies, the Board of Editors advises Subscribers to place standing orders with the Journal Local Agents or with the Managing Editor

**THE POST OFFICE
ELECTRICAL ENGINEERS' JOURNAL**
G.P.O. (Alder House) London, E.C.1

FERRANTI

The Ferranti Clip-on Ammeter enables you to measure the current in any circuit quickly and safely. It is merely clipped on to the cable and the instrument immediately registers.



*Change
over*
From one range
to another
simply by a turn
of this switch

PRICES

Single Range :
From 0 to 7.5 amps. up
to 0 to 1000 amps.
. . . . from £5-5-0 to £7-15-0

Dual Range :
From 0-10-50 amps. up to 0-100-
1000 amps.
. . . . from £5-15-0 to £8-10-0

This instrument possesses several important features :—Two ranges in the one instrument. Self-aligning core with insulation covering. Insulating jaws take cables up to 2 inches. Good damping. Single-handed operation. Net weight : 2-lbs. 2-ozs.

Fulllest particulars on application. Write for List In.11.

FERRANTI LTD., HOLLINWOOD, LANCS.
LONDON OFFICE : BUSH HOUSE, ALDWYCH, W.C.2

Differential Moving Coil **MILLIAMMETERS** For Telegraph Circuits

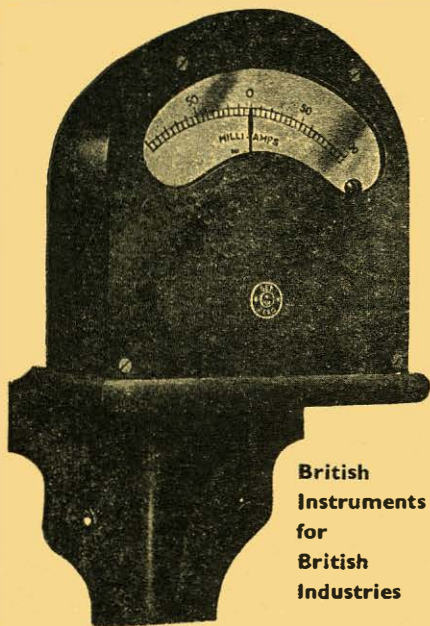

T. 1098. WALL MOUNTING TYPE.

British
Instruments
for
British
Industries

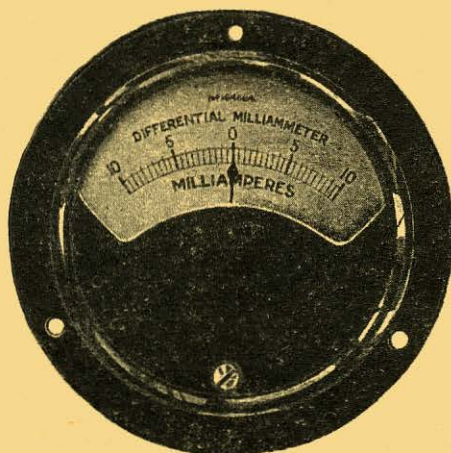

T. 1089. PANEL MOUNTING TYPE.

Frequency and many other Telegraph Systems, also for testing purposes in connection with Land Line and Radio Communication.

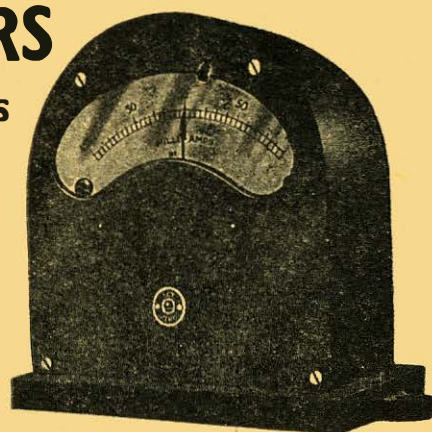

T. 1097. TABLE MOUNTING TYPE.

TABLE, WALL AND PANEL MOUNTING TYPES

INVALUABLE as line Milliammeters on Differential Duplex, Sub-Audio

ELLIOTT BROTHERS (London) LTD., Century Works, Lewisham, S.E.13

Telephone :
Lee Green 4646

in association with

SIEMENS BROTHERS & COMPANY, LIMITED, Woolwich, London, S.E.18

Telephone :
Woolwich 1161

Particulars will be sent on request.

ANACOS

REGD

BRONZE & CADMIUM COPPER WIRES

SEND US PARTICULARS
OF YOUR JOB, AND OUR
TECHNICAL ENGINEERS
WILL PROVIDE YOU WITH
THE DATA YOU NEED.

FREDERICK SMITH & COY.

INCORPORATED IN THE LONDON ELECTRIC
WIRE COMPANY AND SMITHS, LIMITED
Anaconda Works, Salford 3, Lancs.

Tel. : Blackfriars 8701 (8 lines) Telegrams : "Anaconda, Manchester."

AS SUPPLIED TO

**H.M. POST OFFICE
FOR
TELEPHONE LINES**

SILICIUM-BRONZE, COPPER

COPPER - CADMIUM

TAPES & BINDERS

LONDON-CAMBRIDGE

— 53 MILES —

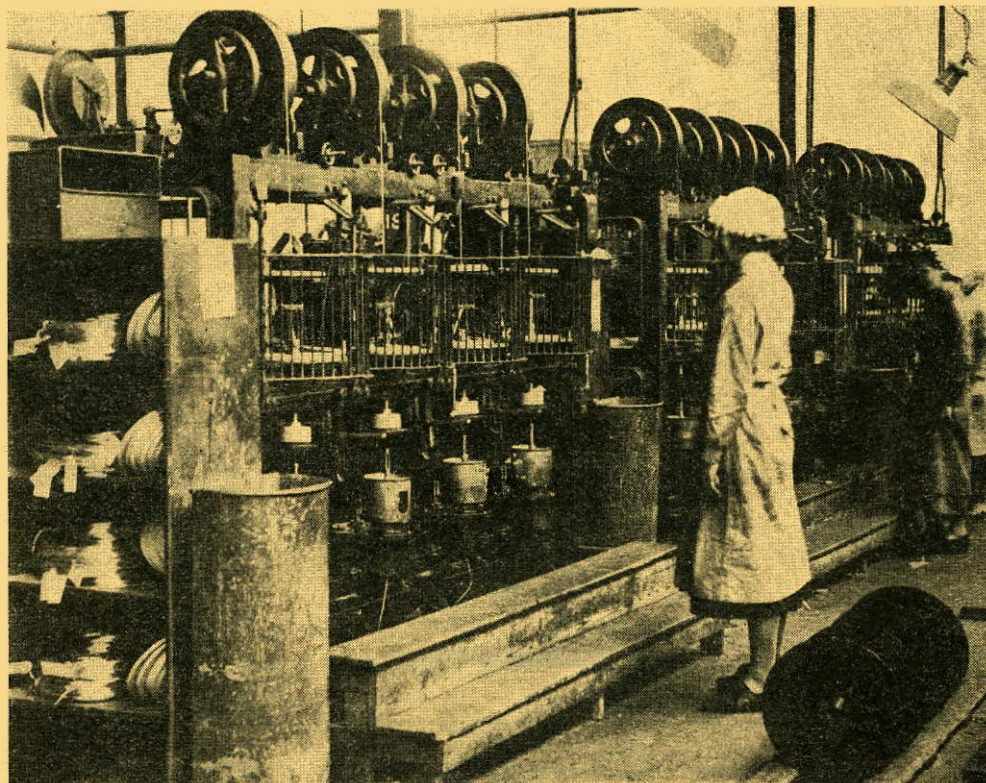

WE ARE AT PRESENT MANUFACTURING AND
INSTALLING FOR THE G.P.O. TWO 24 pr/40 lb.
P.C.Q.T. CARRIER TYPE CABLES IN THE SAME DUCT
FOR A TWELVE CHANNEL CARRIER SYSTEM SUITABLE
FOR TRANSMITTING FREQUENCIES UP TO 60 Kcs.

Our illustration shows Insulating Machines at work on this Contract.

TELEPHONE:
SOUTHAMPTON
2141 (5 lines).

PIRELLI-GENERAL
CABLE WORKS, Ltd., SOUTHAMPTON.

TELEGRAMS
"PIGEKAYBEL"
SOUTHAMPTON

Proprietors: PIRELLI, Ltd., and THE GENERAL ELECTRIC CO., LTD.