

THE POST OFFICE ELECTRICAL ENGINEERS' JOURNAL

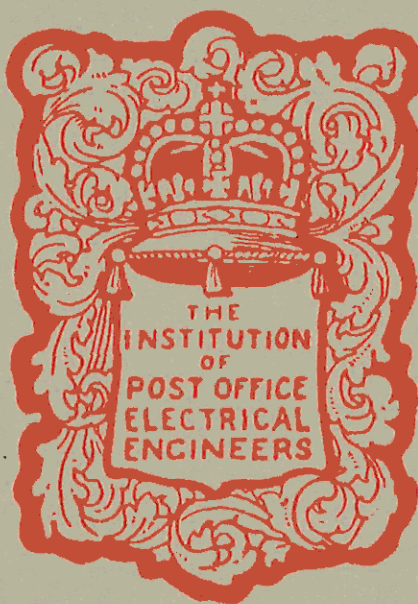

VOL. 26
PART 2

JULY
1933

Price 1/- net.

ADVERTISEMENT INDEX
see page xxi.



THE WORLD OVER

ALTON Batteries are in
service in:

BRITISH ISLES	GREECE
AMERICA	GRENADA
ARGENTINA	INDIA
AUSTRALIA	ITALY
AFRICA	JAMAICA
BURMA	MALAYA
CANADA	MALTA
CEYLON	MANCHURIA
CHINA	NEW ZEALAND
COLOMBIA	NYASALAND
EGYPT	PERU
FIJI ISLANDS	PORTUGAL



So fast and so far has the reputation of Alton Batteries of Merit gone, that in a comparatively few years Telephone Exchanges in the four corners of the world are depending upon them for unremitting service. Far and wide, batteries not originally of Alton manufacture are being replated with Alton plates.

THE
ALTON BATTERY COMPANY
LTD.

Telegrams:
"BATTERY
ALTON."

Telephone:
ALTON
67.

LONDON OFFICE: DONINGTON HOUSE, NORFOLK STREET, STRAND, W.C.2
TELEPHONE: TEMPLE BAR 9265-6

TELEGRAMS: BATTERICOL, ESTRAND, LONDON

STROWGER AUTOMATIC TELEPHONY

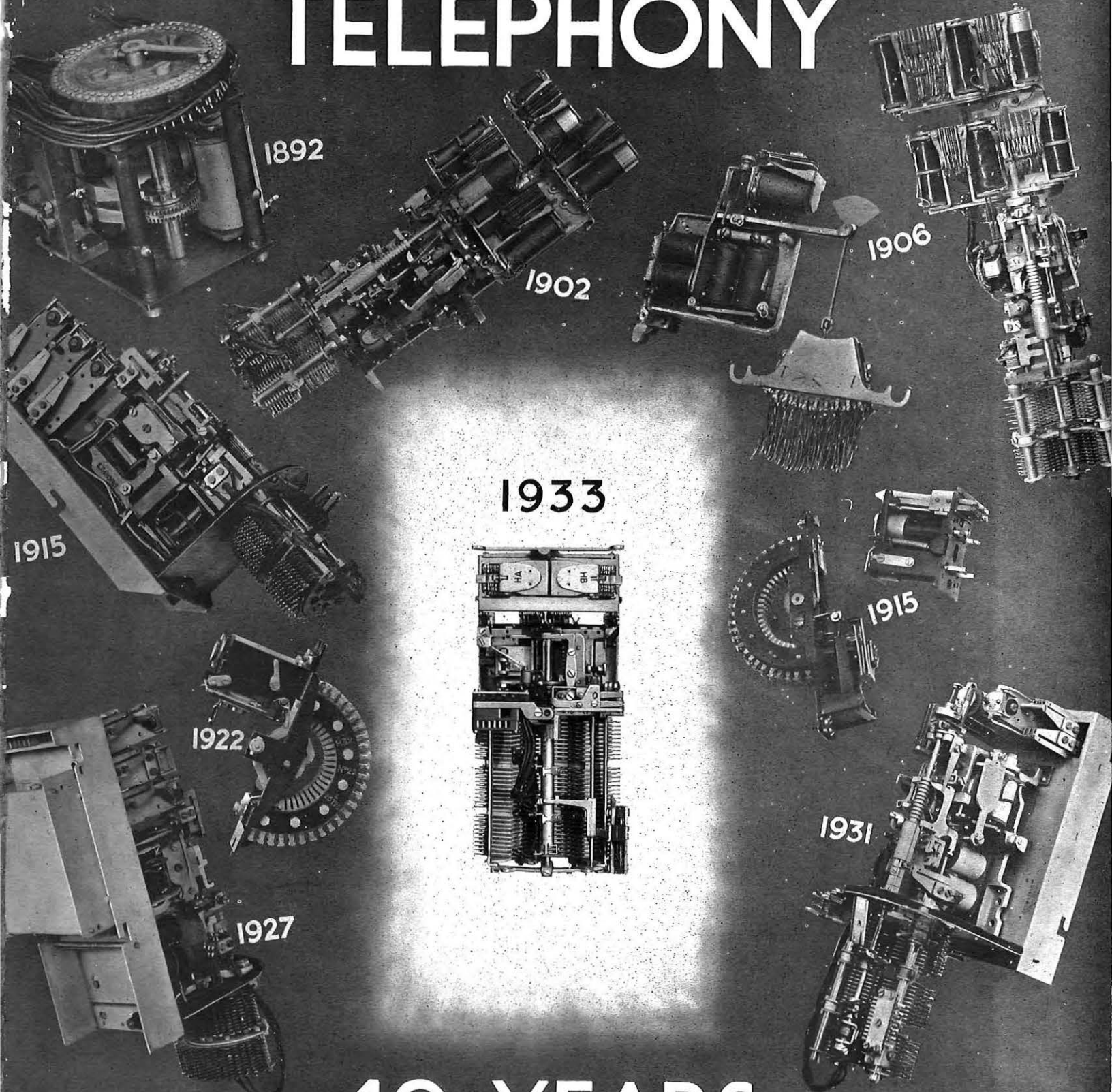

1892

1902

1906

1915

1933

1915

1922

1931

1927

**40 YEARS
SOUND ENGINEERING DEVELOPMENT
AND WORLD-WIDE OPERATING EXPERIENCE**

CANAL
NEW YORK

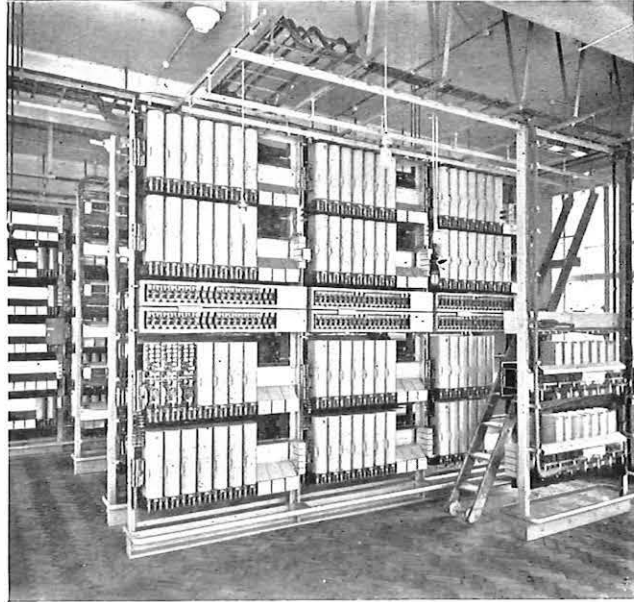
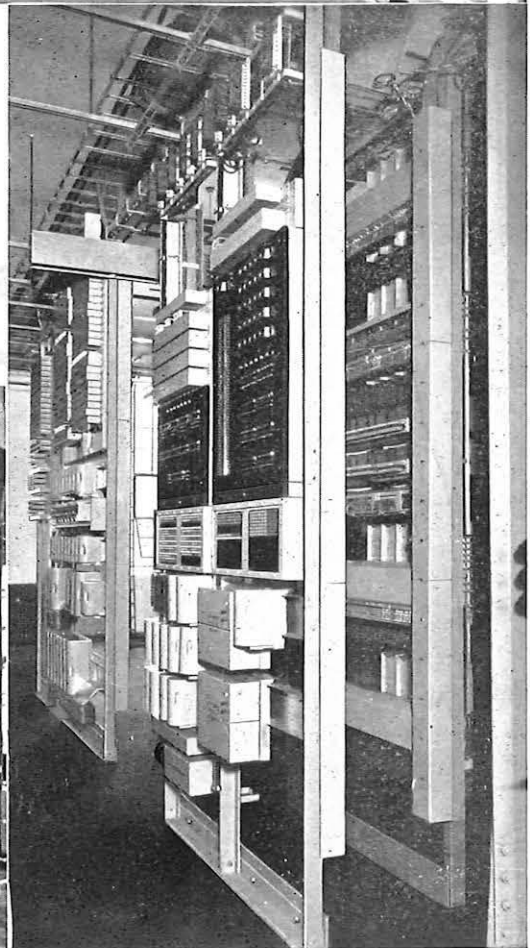
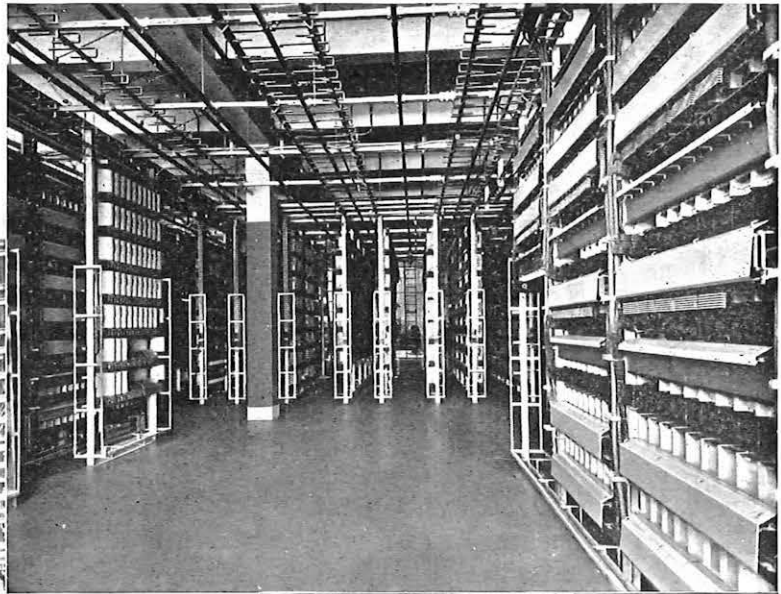

75% of the World's Auto

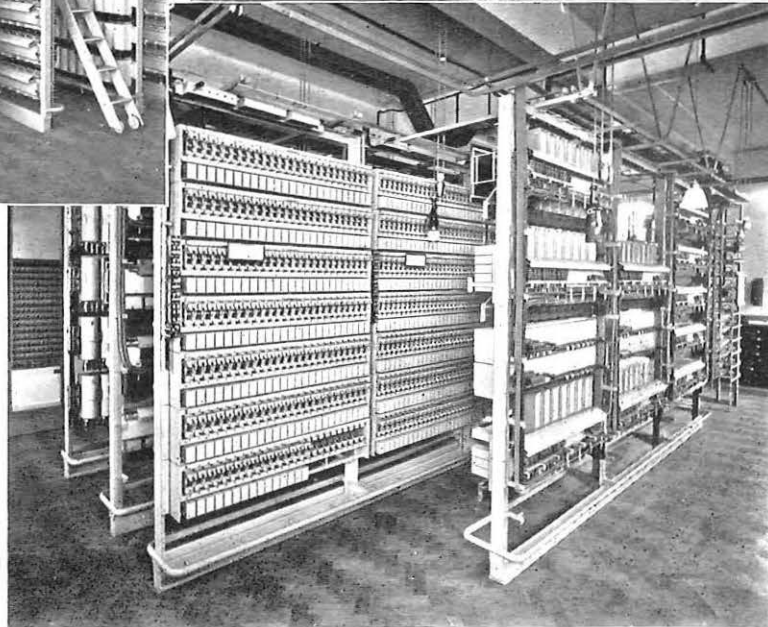
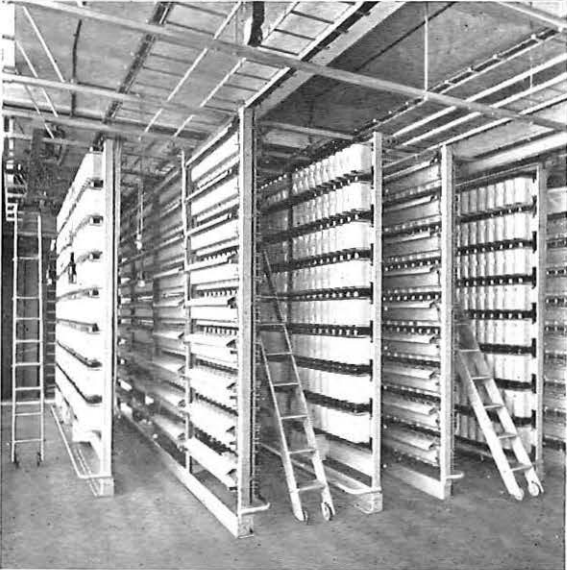
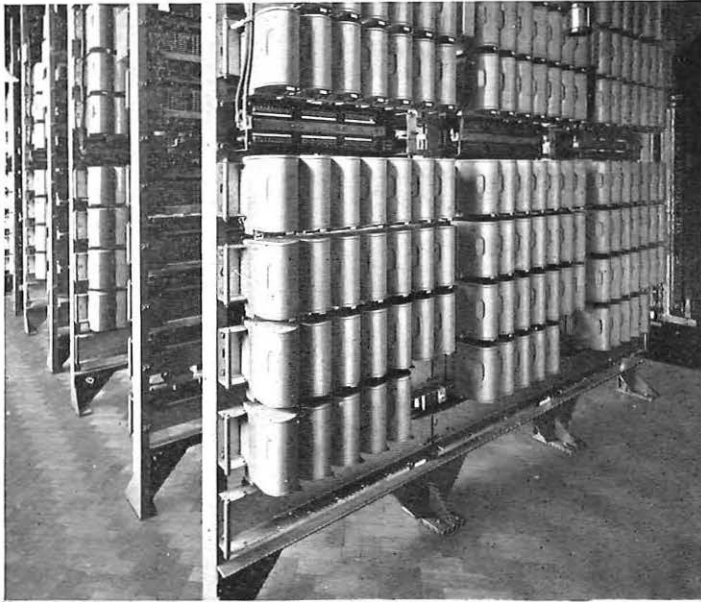

matic Telephones are Stronger!

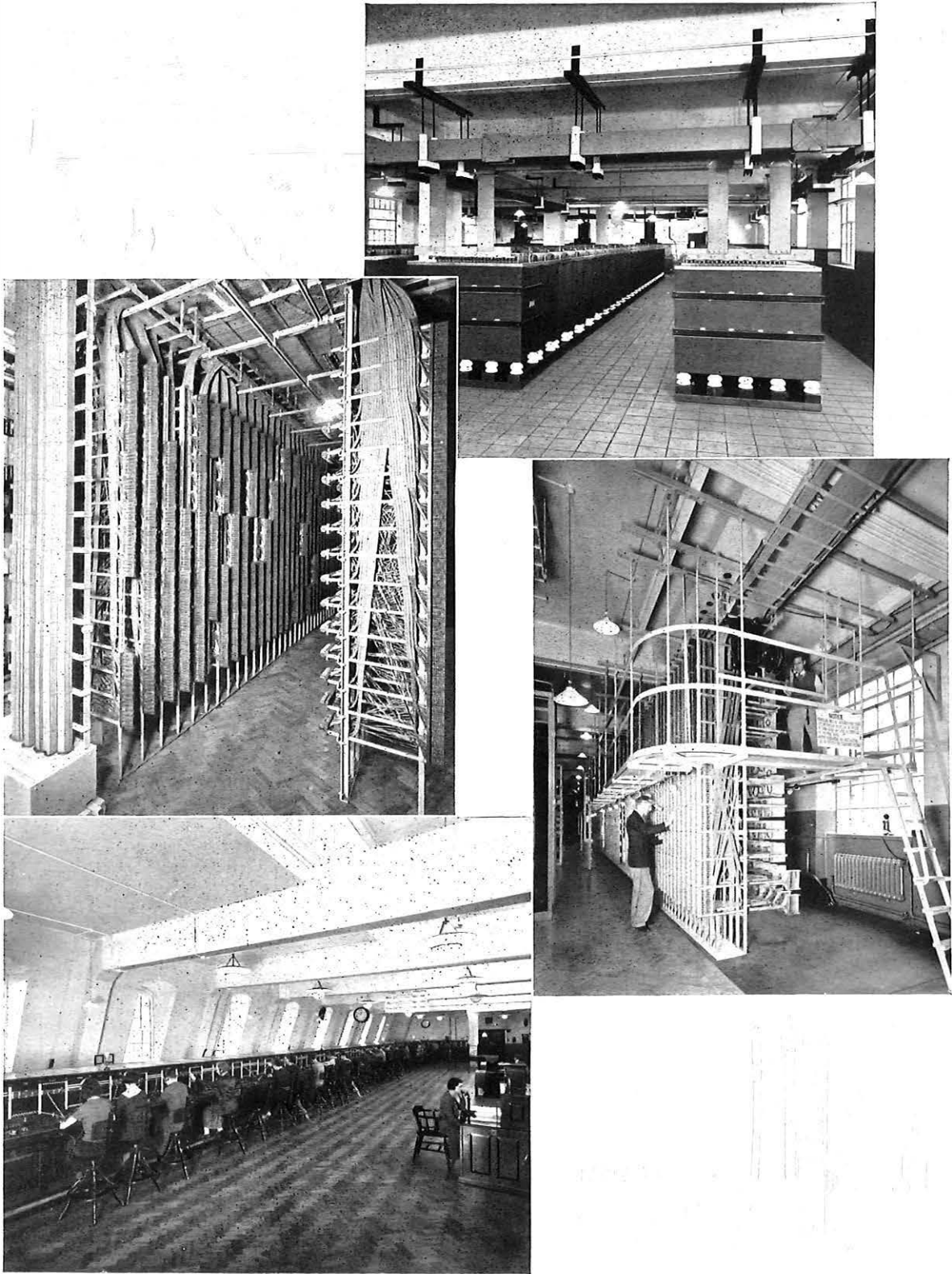

There are more than 8,000,000

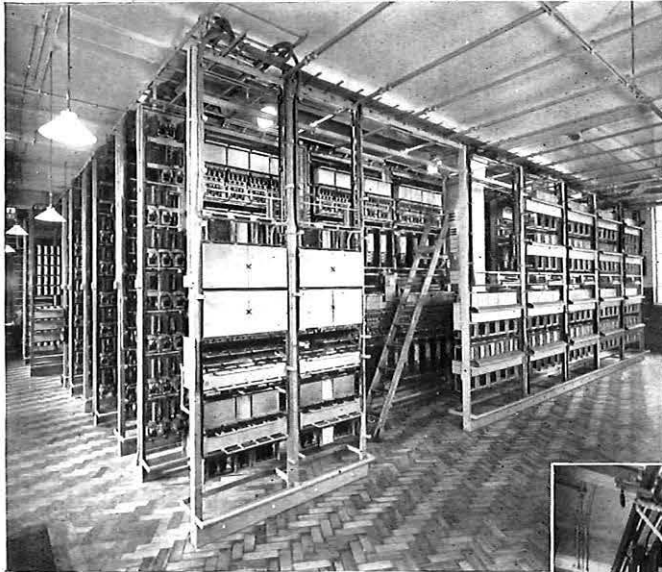
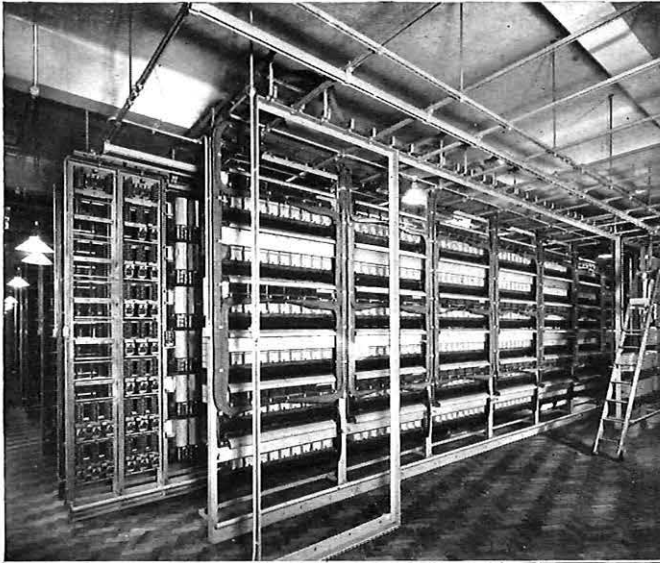

Strowger Telephones in Service !

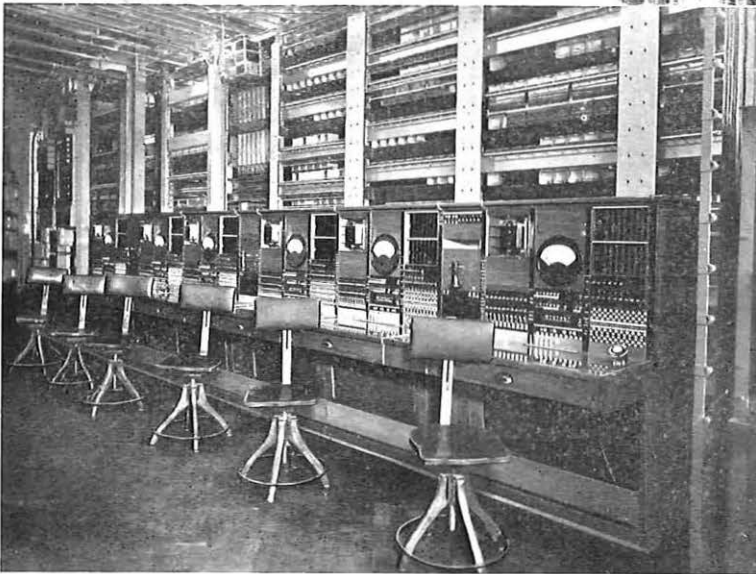
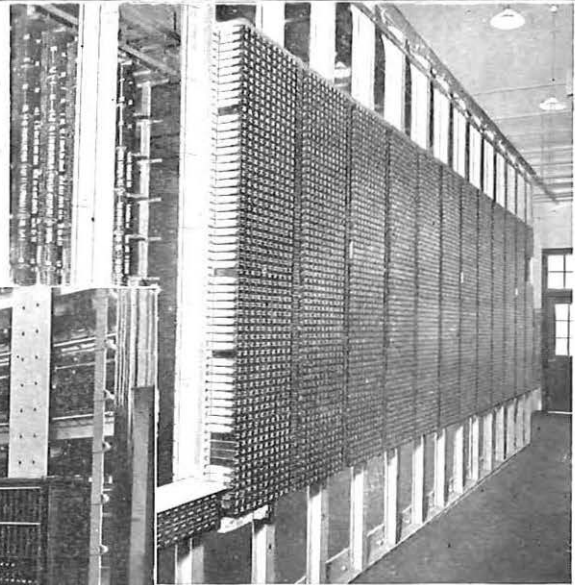
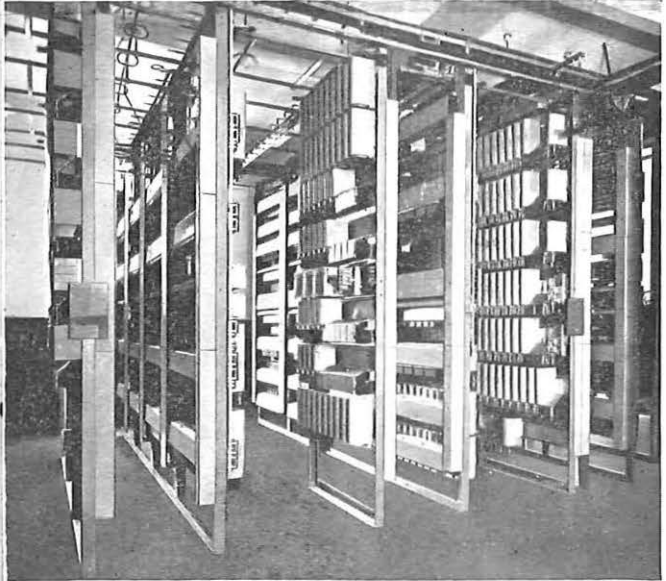
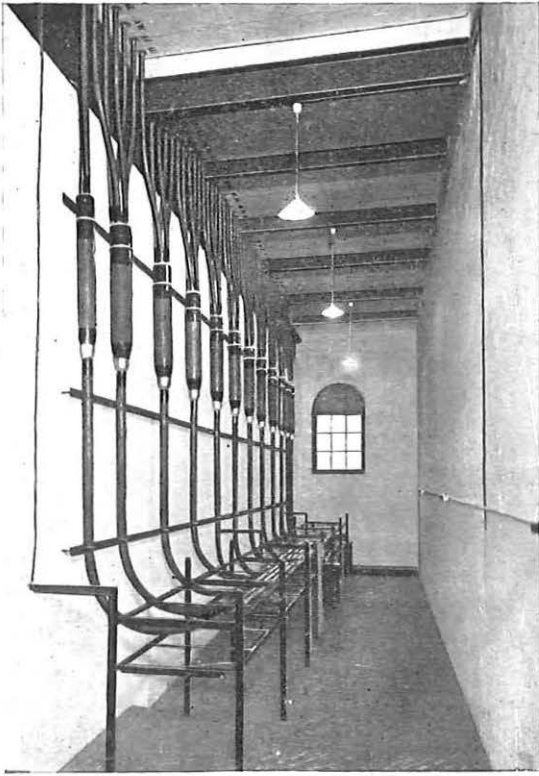

The largest telephone net

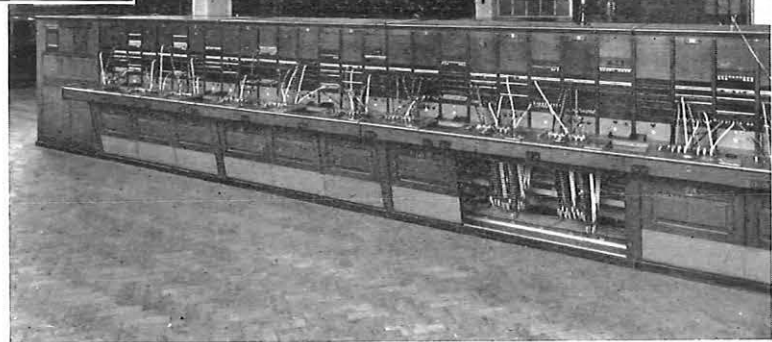
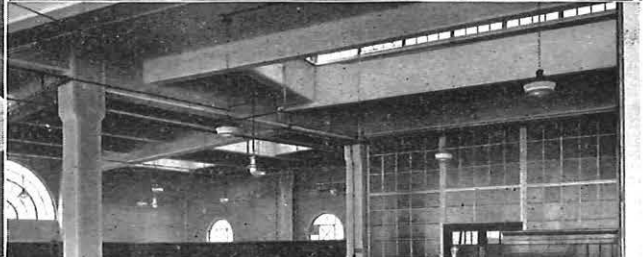
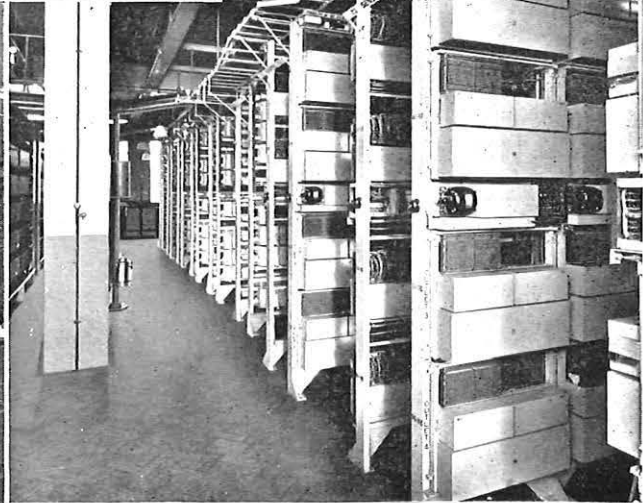
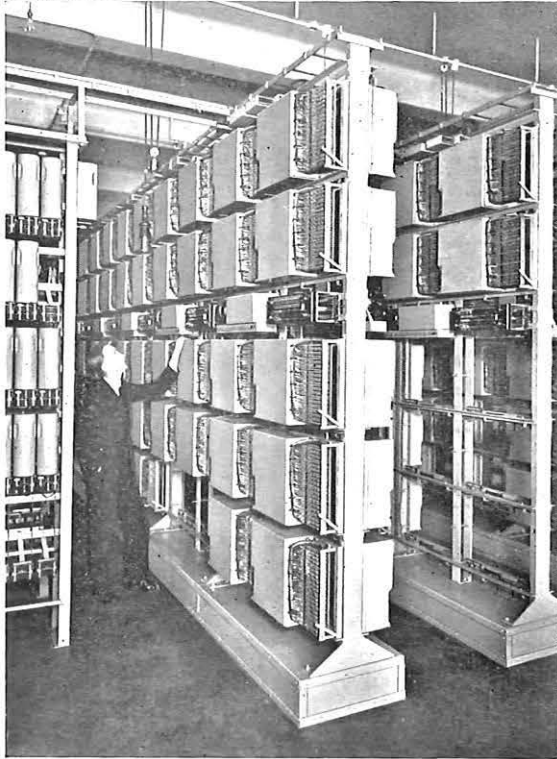
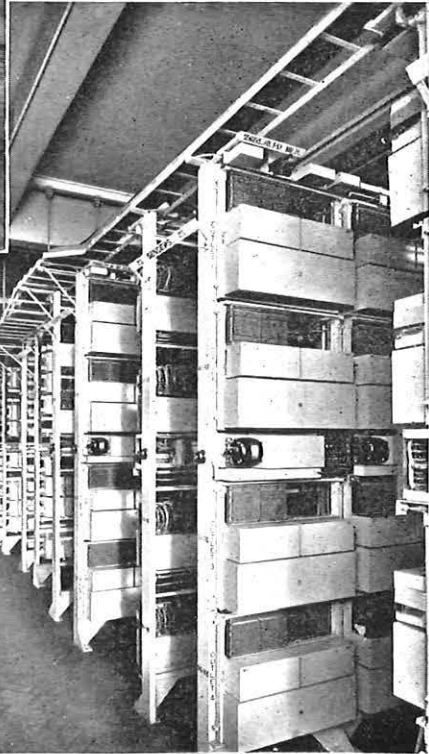
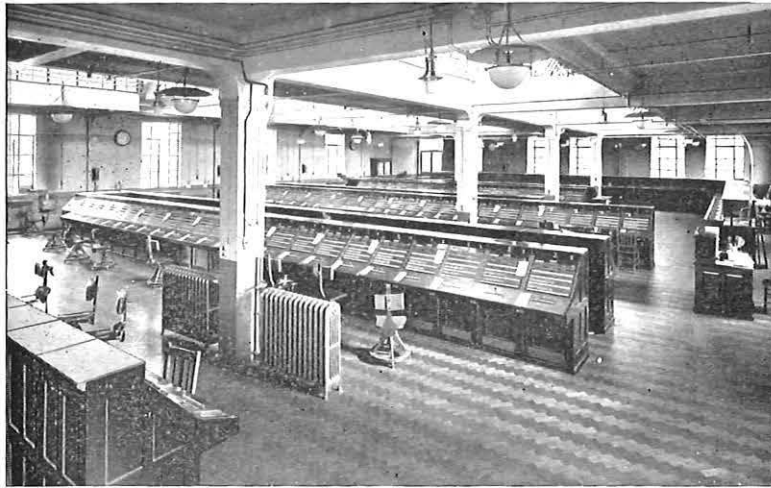

work in Europe is Strowger!

THROUGH 40 years of Strowger Automatic Telephony—the pioneer system—Automatic Electric Co. Ltd., its predecessors and associates have continuously developed and adapted the fundamental invention. To-day 75% of the world's automatic telephones are Strowger.

Although great advance is evident in design, the basic switching principle remains identical with that adopted in early days. Strowger Automatic Telephony in its latest form—the Line Finder System—secures the utmost saving in apparatus and floor space consistent with highest-grade service and economical maintenance.



AUTOMATIC ELECTRIC COMPANY LIMITED.

STROWGER WORKS - : - LIVERPOOL

Telephone: Old Swan 830.

Telegrams: "Strowger," Liverpool.

MELBOURNE HOUSE, ALDWYCH, LONDON, W.C.2.

Telephone: Temple Bar 4506.

Telegrams: "Strowger Estrand," London.

66 Countries have adopted Strowger!

PITMAN'S BOOKS

STANDARD WORKS

TELEPHONY—Vol. I. MANUAL SWITCHING SYSTEMS AND LINE PLANT.

By T. E. HERBERT, M.I.E.E., *Superintending Engineer, P.O. Engineering Department*, and W. S. PROCTER, A.M.I.E.E., *Engineer-in-Chief's Office, P.O. Engineering Dept.* Demy 8vo, cloth gilt, 1220 pp. 20s. net. Second Edition.

TELEGRAPHY.

By T. E. HERBERT, M.I.E.E., etc. Demy 8vo, cloth gilt, Fifth Edition. 20s. net.

SUBMARINE TELEGRAPHY.

By ING. ITALO DE GIULI. Translated by J. J. McKICHAN, O.B.E., A.M.I.E.E. Demy 8vo, cloth gilt, 250 pp. 18s. net.

MODERN RADIO COMMUNICATION.

By J. H. REYNER, B.Sc., A.C.G.I., A.M.I.E.E., M.Inst.R.E. Crown 8vo, cloth gilt, 330 pp. Fourth Edition. 5s. net.

ACOUSTICAL ENGINEERING.

By W. WEST, B.A., A.M.I.E.E., *of the Research Staff.* Demy 8vo, cloth gilt, 350 pp. 15s. net.

ELECTRICAL TRANSFORMER THEORY

By S. GORDON MONK, B.Sc., A.M.I.E.E., M.J.I.E.

This new explanation of transformer theory is calculated to afford the maximum assistance to the student studying this branch of electrical engineering. It has been thought out and planned along original lines. The explanation of the vector diagram, for instance, is unique in that the leakage reactance is dealt with in one operation, using the "equivalent" value obtained from practical tests. This, and other special features, together with its simple treatment of all involved technical problems, render the book of outstanding value for systematic instruction and reference. 148 pp. 5s. net.

RELAYS IN AUTOMATIC TELEPHONY

By R. W. PALMER, A.M.I.E.E.

Explains the construction, design and adjustment of relays together with the theory of impulsing and the measurement of time lags. The scope of the work has been largely determined by the syllabus of the City and Guilds of London Institute Examination with respect to telephone relays, which it covers in detail. It is also a standard work of reference for telephone engineers. 190 pp. 10s. 6d. net.

Write for a complete list of Pitman's Technical and Scientific Books. Post free on application.

SIR ISAAC PITMAN & SONS, LTD., Parker Street, Kingsway, London, W.C.2

The Institution of Post Office Electrical Engineers PRINTED PAPERS.

The following papers contributed to the proceedings of the Institution have been printed by authority of the Council and may be obtained from

*The Librarian,
The Institution of Post Office Electrical Engineers,
G.P.O., Alder House, London, E.C. 1.*

The prices do *not* include postage.

No. 134.	"SOUND AND HEARING."—N. F. CAVE-BROWNE-CAVE, B.Sc., M.I.E.E. 1930	1s.
No. 136.	"SOME DEVELOPMENTS IN TELEGRAPH TECHNIQUE AS APPLIED TO RADIO CIRCUITS."—H. FAULKNER, B.Sc. (Hons.), A.M.I.E.E., and G. T. EVANS. 1931	1s.
No. 137.	"INTERFERENCE WITH WIRELESS RECEPTION ARISING FROM THE RECEPTION OF ELECTRICAL PLANT."—Col. A. S. ANGWIN, D.S.O., M.C., T.D., B.Sc., M.I.E.E. 1932	6d.
No. 138.	"TELEPHONE CABLE TESTING (INCLUDING FAULT LOCALISATION)."—W. T. PALMER, B.Sc., Wh. Ex., A.M.I.E.E., and E. H. JOLLEY, A.M.I.E.E. 1931	1/3
No. 140.	"SOME NON-METALLIC SUBSTANCES AND THEIR CHARACTERISTICS."—Capt. N. F. CAVE-BROWNE-CAVE, B.Sc., A.M.I.E.E. 1931	9d.
No. 141.	"THE TELEPRINTER No. 7A (Creed Teleprinter)."—R. D. SALMON. 1932	9d.
No. 142.	"PRIVATE BRANCH EXCHANGE INSTALLATIONS."—R. T. A. DENNISON. 1932	1/3
No. 143.	"ELECTRIC WAVE FILTERS."—G. J. S. LITTLE, B.Sc. 1931	1/3
No. 144.	"SOME NOTES ON THE DESIGN AND MANUFACTURE OF TELEPHONE CABLES."—F. H. BUCKLAND and R. H. FRANKLIN, B.Sc. 1932	1s.

The Post Office Electrical Engineers' Journal.

A QUARTERLY JOURNAL.

COPYRIGHT.—The entire contents of this Journal are covered by general copyright, and special permission is necessary for reprinting long extracts, but Editors are welcome to use not more than one third of any article, provided credit is given at the beginning or end thus: "From the 'Post Office Electrical Engineers' Journal.'"

The Board of Editors is not responsible for the statements made nor the opinions expressed in any of the articles in this Journal, unless such statement is made specifically by the Board.

CONTENTS FOR JULY, 1933.

	PAGE
TELEPRINTER PRIVATE WIRES ON BY-PRODUCT CIRCUITS—R. G. DE WARDT, A.M.I.E.E., M.I.Rad. E.	83
A SIMPLIFIED CARRIER TELEPHONE SYSTEM FOR OPEN LINES—R. J. HALSEY, B.Sc., A.C.G.I., D.I.C.	90
INDUCTIVE INTERFERENCE FROM FAULT CURRENTS ON E.H.T. POWER LINES—A. J. JACKMAN, B.Sc., A.C.G.I., A.M.I.E.E.	97
TELEGRAPH AND TELEPHONE PLANT IN THE UNITED KINGDOM	106
RECENT DEVELOPMENTS IN THE DESIGN OF LOADING EQUIPMENT FOR JUNCTION CABLES—A. O. GIBBON, M.I.E.E., and W. H. BRENT, B.Sc. (Hons.)	107
THE NEW AGREEMENTS FOR WAYLEAVE AND MAINTENANCE OF P.O. PLANT ON RAILWAYS	114
THE WITWATERSRAND AUTOMATIC TELEPHONE SYSTEM—H. A. JOHNSON, B.A. (Hons.)... ..	116
COUNTRY SATELLITE EXCHANGES—H. O. ELLIS and B. WINCH	125
MISCELLANEOUS FACILITIES AT AUTOMATIC AND MANUAL TELEPHONE EXCHANGES —A. HOGBIN	131
THE SNOW STORM OF FEBRUARY, 1933—CAPT. J. G. HINES	133
A WIRE STRINGING TOOL	136
SMALL AUTOMATICALLY CONTROLLED POWER PLANTS—H. C. JONES, B.Sc., Eng., and H. S. WATERS	137
THE USE OF BALLAST RESISTANCE IN TRANSMISSION BRIDGES—F. B. CHAPMAN, A.M.I.E.E.	140
WIGAN EXCHANGE—A. G. LYDDALL	145
RESEARCH	150
NOTES AND COMMENTS	152
DISTRICT NOTES	153
INSTITUTION OF POST OFFICE ELECTRICAL ENGINEERS	156
LOCAL CENTRE NOTES	157
JUNIOR SECTION NOTES	158
BOOK REVIEWS	158
STAFF CHANGES	160

All communications with regard to Advertisements to be addressed to:

The Advertisement Manager,

Post Office Electrical Engineers' Journal,

Dorset House, Stamford Street, London, S.E.1.

PUBLISHERS:

The Electrical Review, Dorset House, Stamford Street, London, S.E.1

Single copy 1/- net, post free, 1/3.

Annual Subscription, postage
inclusive, 5/-, payable in advance.

Exchange after Exchange is being installed by Ericsson

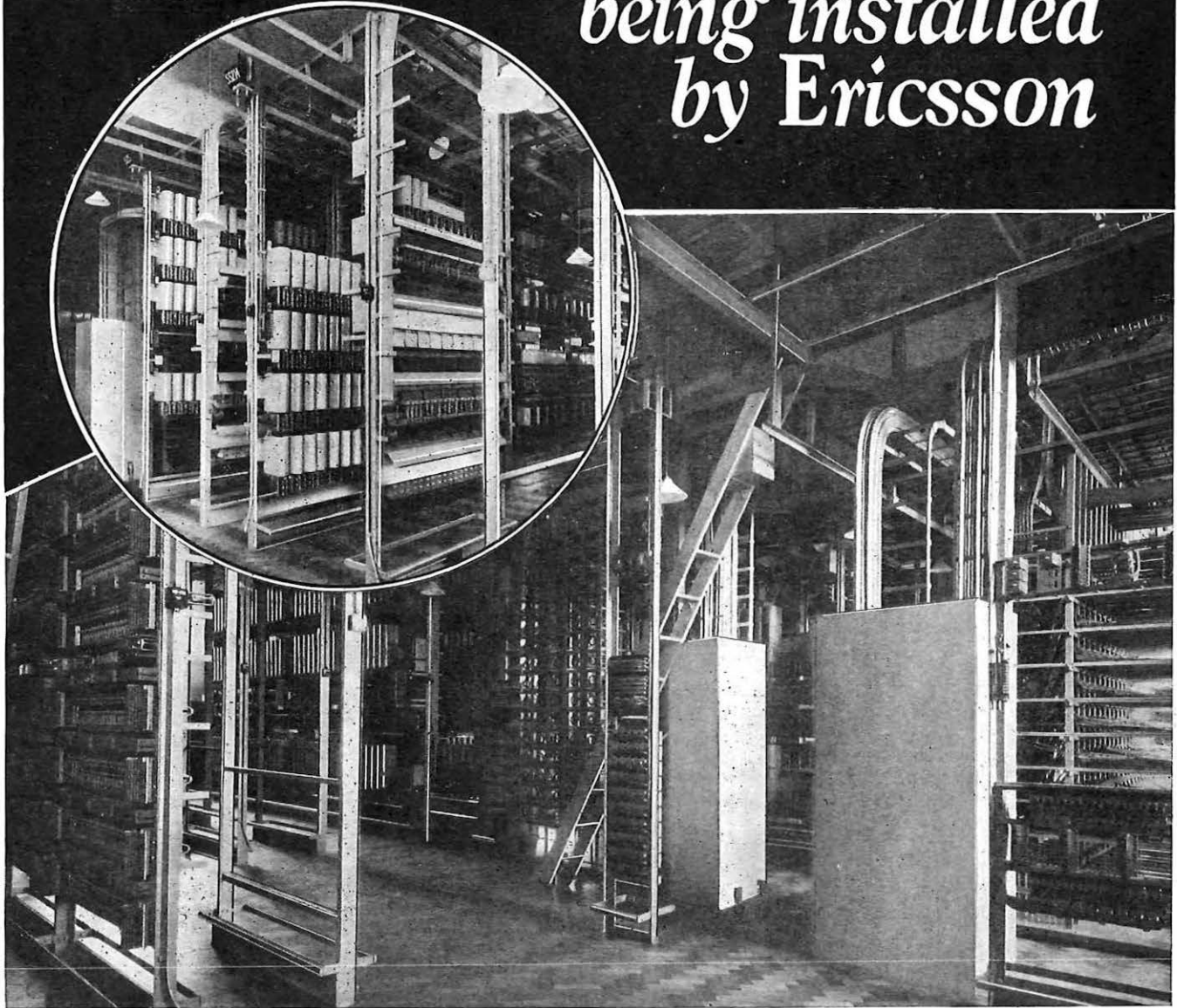

● (In Circle) View of
Second Code Selector
and Director Racks.

● (Main Illustration)
View of Automatic
Switch Room at Colin-
dale (Director) Tele-
phone Exchange.

“Keeping pace with progress” has ever been the policy of the House of Ericsson.

The result of this policy is that we are installing one automatic exchange after another.

We manufacture, supply, and install complete automatic exchange equipments of the “director” and “non-director” types for any number of lines.

Informative literature sent free.

ERICSSON TELEPHONES LIMITED

67/73, KINGSWAY, LONDON, W.C.2

Telephone: Holborn 3271/3

Works: Beeston, Notts

Ericsson

**TELEPHONE
EXCHANGE
EQUIPMENT**

ALL THE UNIQUE
"THE WORLD'S MOST E"
NOW INCORPORATED IN TELEPHONE

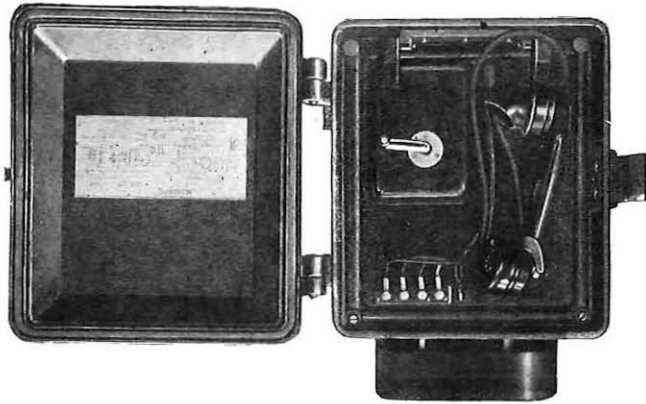

"NEOPHONES" of the following type
 are now available :

- AUTOMATIC
- CENTRAL BATTERY
- MAGNETO
- BATTERY CALL
- INTERCOMMUNICATION

STANDARDIZED by the
 Union of South Africa
 important overseas t
 Siemens "Neophone" ha
 knowledged as "The Wor
 Now . . . the exclusive "
 been embodied in a wid
 instruments. These new
 designed to serve a greatl
 illustrations demonstrate th
 each instrument is first ar
 which means that it gives
 articulation unequalled i

"SIEM
NEOP

SIEMENS BROTHERS & CO., LTD

Telephone: W

REPRESENTATION ABROAD : Winnipeg, Rio de Janeiro, Buenos Aires, Cairo, Cape Town, Johannes-
 burg, Port Elizabeth, Durban, Melbourne, Sydney, Brisbane, Adelaide, Newcastle (N.S.W.), Perth,

THE ADVANTAGES OF EFFICIENT TELEPHONE

INSTRUMENTS OF EVERY TYPE



the British Post Office and the
and adopted by many other
telephone administrations, the
s come to be universally ac-
d's most efficient telephone."
"Neophone" principles have
le range of special-purpose
"Neophones" have been
extended field of use, and the
eir character and variety. Yet
d foremost a "Neophone"
a quality of transmission and
the sphere of telephony.



Full particulars
of any type
of instrument will
be sent on request.

SIEMENS PHONE

., WOOLWICH, LONDON, S.E.18

oolwich 1161

Wellington, Auckland, Tokyo, Shanghai, Tientsin, Harbin, Calcutta, Bombay, Madras,
Colombo, Ipoh, (Perak F. M. S.), Kuala Lumpur, Singapore, Penang, The Hague, Malta.

EVERYTHING



ELECTRICAL

G.E.C.

LINE CONTACT TYPE

AIR CIRCUIT BREAKERS

Patent Nos. 290819 and 297164.

MADE IN ENGLAND.

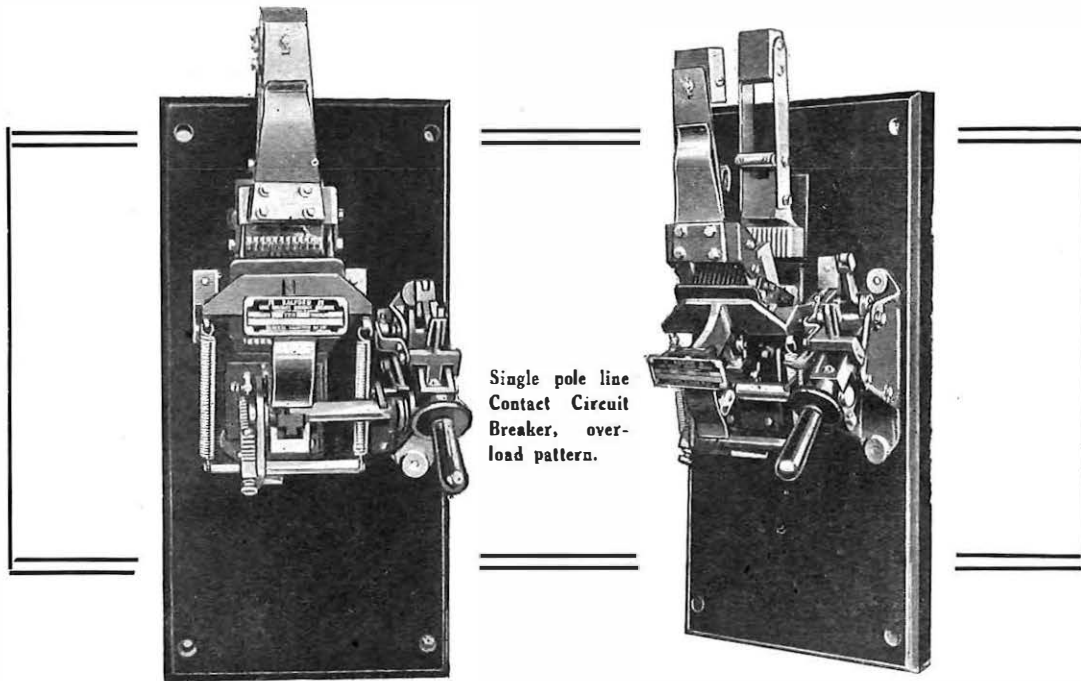

Single pole line
Contact Circuit
Breaker, over-
load pattern.

Entirely NEW Design for Circuit Breakers

Brushes eliminated.

High conductivity copper blades which are instantly removeable and replaceable now take the place of that ever troublesome feature of circuit breaker design, the brush.

G.E.C. Line contact type air circuit breakers are made with capacities up to 10,000 amps. and up to 660 volts, A.C. or D.C., single, double, or triple pole. Can be fitted with either manual or electrical closing gear.

Made at the SALFORD ELECTRICAL INSTRUMENT WORKS of

THE GENERAL ELECTRIC CO., LTD.

Head Office: MAGNET HOUSE, KINGSWAY, LONDON, W.C.2

Branches throughout Great Britain and in all the principal markets of the World

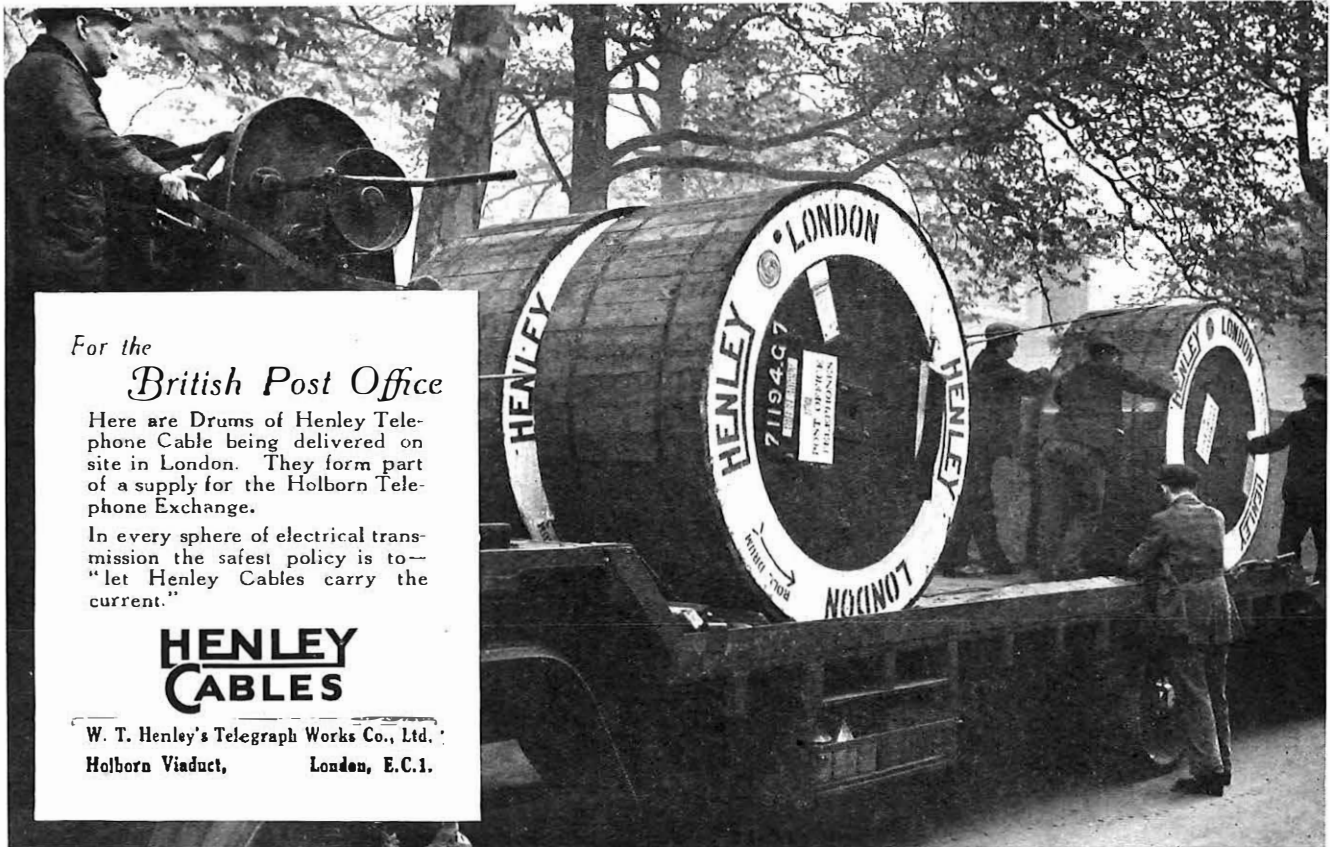

For the
British Post Office

Here are Drums of Henley Telephone Cable being delivered on site in London. They form part of a supply for the Holborn Telephone Exchange.

In every sphere of electrical transmission the safest policy is to—"let Henley Cables carry the current."

**HENLEY
CABLES**

W. T. Henley's Telegraph Works Co., Ltd.
Holborn Viaduct, London, E.C.1.

**TURNER DIFFERENTIAL
MILLIAMMETERS
G.P.O. No. 17
& No. 18**

Meet the most exacting demands for balancing currents in multiplex telegraph circuits.

—A quality product of outstanding merit—

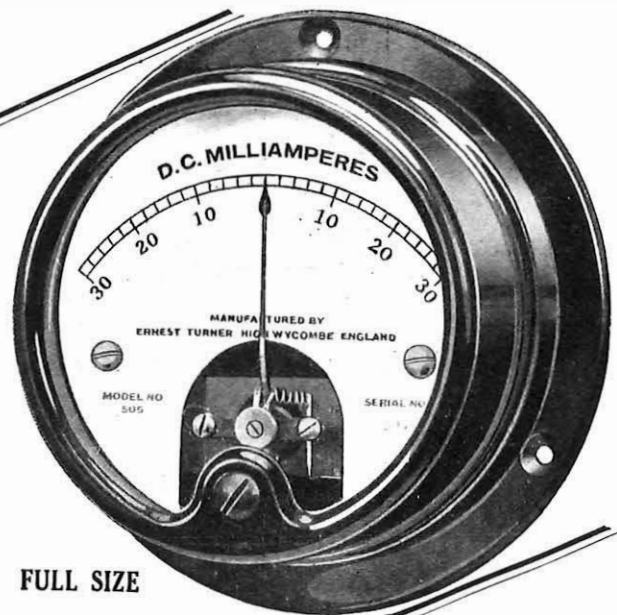

FULL SIZE

Also manufacturers of G.P.O. Detector No. 4, and a comprehensive line of instruments for precision electrical measurements.

ERNEST TURNER ELECTRICAL INSTRUMENTS, Ltd.

**CHILTERN WORKS,
55-73, TOTTERIDGE AVENUE,
HIGH WYCOMBE,**

BUCKS. ENGLAND

Telephone: High Wycombe 301.
Telegrams: Gorgeous, High Wycombe.

Standard

BYPATH AUTOMATIC SYSTEM

This new automatic telephone system has been designed to cater for all modern requirements. It offers definite economies in initial cost, floor space, junctions, weight of equipment, and maintenance charges.

The Bypass system is a uniselector system using one type of switch throughout.

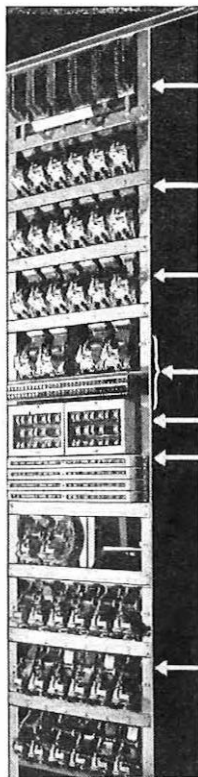

← TERMINAL STRIPS FOR EASY CABLING

← UNIT BAY CONSTRUCTION

← ONE TYPE UNISELECTOR THROUGHOUT

← BYPATH CONTROL

← JACK-IN RELAY PANELS

← TRANSPARENT WINDOWS

← ALL ROTORS JACKED-IN AND INTERCHANGEABLE

Typical Bypass Bay

BYPATH EXCHANGES

The Bypass System can be used in large or small exchanges of every type. Bypass Exchanges now in operation or under construction, include :

Advance Exchange - London

Burton-on-Trent - Multi-office area

Tutbury }
Swadlingcote } Satellite exchanges

Great Wakering }
Stapleford } Rural exchanges

Theydon Bois - Urban exchange

Standard Telephones and Cables Limited

AERODROME ROAD, LONDON, N.W.9

Telephone: Colindale 6533

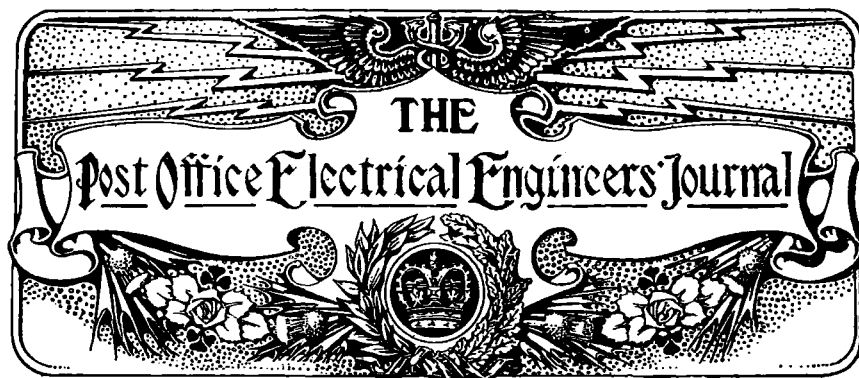

Teleprinter Private Wires on By-Product Circuits

R. G. DE WARDT, A.M.I.E.E., M.I.Rad. E.

SINCE 1927, the majority of main telephone cables laid in this country have their conductors arranged on the star quad principle. In this type of cable, derived phantom circuits are unsuitable for telephone circuits but can be utilized for telegraph circuits.

The majority of cables laid prior to this date were of the multiple twin type and were, in most cases, balanced and loaded so that the derived phantom circuits were suitable for telephone circuits. Telegraph circuits can, however, be superposed on the phantom circuits in these cables.

It will therefore be seen that in consequence of the large trunk telephone development in the country, a considerable number of telegraph circuits in excess of the number required for the public telegraph service have become available. This fact, conjointly with the introduction of the page printing teleprinter in commercial production, led to the decision to offer telegraph private wire circuits to renters at attractive tariffs.

The types of service now offered by the Department using these phantoms or "by-product" circuits are as follows:—

1. *Tariff A.* A simplex teleprinter service between renters' offices using Teleprinters 7A provided and maintained by the Department.
2. *Tariff B.* A duplex telegraph circuit having an equivalent line speed of 40 cycles per second on which the Renter can provide his own instruments or utilize teleprinters provided and maintained by the Department.

The by-product circuits provided for either of these tariffs are derived from loaded side circuits in the case of star quad cables and from loaded phantoms in multiple twin cables. In most cases, there are one or more telephone repeaters in the telephone circuits en route and, in order that satisfactory working of both the telephone and super-

posed telegraph may be practicable, the telegraph circuit arrangements have to meet the following conditions:—

- (a) The circuit must be capable of operation with small line voltages and currents in order to reduce interference with telephone circuits to a minimum. The limits were fixed at 40 volts and 10 milliamperes respectively.
- (b) Currents of telephone frequency must be filtered from the telegraph signal.
- (c) The circuit must not cause inductive interference with other telegraph circuits.

These limitations, combined with the fact that the by-product circuits have a high K.R. and also that it was desired to restrict the apparatus at the renters' offices to a minimum in order to simplify maintenance and to utilize the local telephone network for the connexions from renters to the by-product cable ends, set a very difficult problem in the design of the circuit arrangements.

The circuit finally adopted which is applicable with slight modifications to either *Tariff A* or *B* differs considerably from any telegraph circuit previously used by the Department and though of a revolutionary character has justified its adoption and has proved very satisfactory in working.

An examination of the by-product circuits showed that they have a very high K.R. value. For example a London to Birmingham circuit has a K.R. of 64000 ohms-microfarads. It would be impossible to work circuits of a greater K.R. without repeaters, under the voltage and current restrictions imposed, with the necessary degree of margin, repeaters would therefore be required on circuits which on ordinary telegraph cables would be worked direct. In order that these repeaters should be of the simplest possible description, it was decided to utilize duplex conditions on the by-product circuits (although under *tariff A* simplex communication

only is provided) in order to avoid the switching complications necessary on a simplex repeater with alternative directions of working. Duplex conditions on the main line also permit the receiving reenter to interrupt the transmitter at the distant end when required in the case of a Tariff A circuit. Duplex conditions are, of course, essential in the case of Tariff B.

The duplex arrangement finally adopted for the main line portion of the circuit is a modification of the H relay duplex, using a filter and a surge transformer. It is a development of the "H" Relay circuit introduced by the Department some years ago and is shown diagrammatically in Fig. 1.

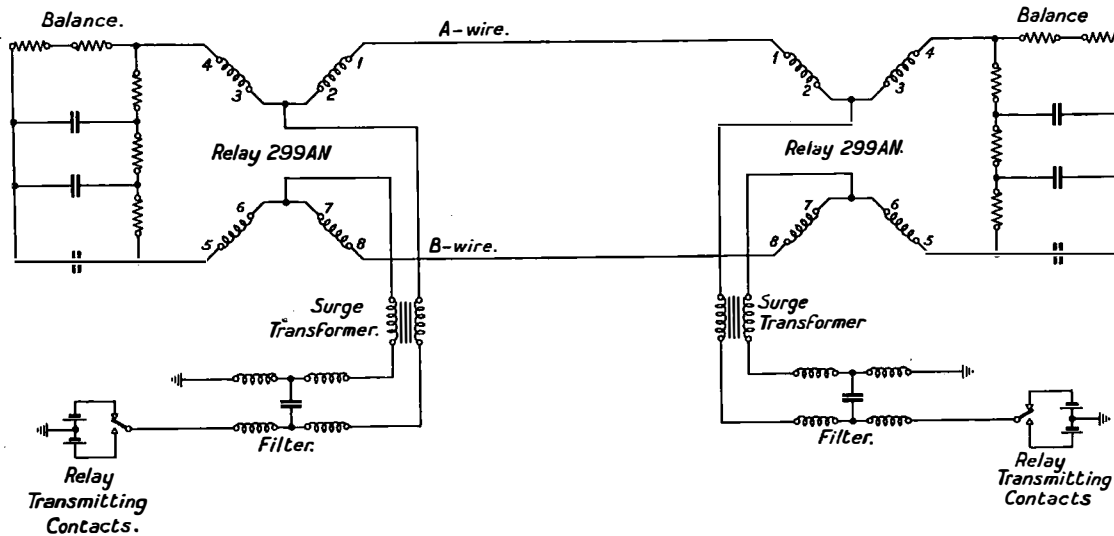

FIG. 1.—DIFFERENTIAL DUPLEX.

The circuit utilizes earthed universal batteries and sensitive four-winding relays of the Standard Telephone Company's 299 AN type. The relay windings are split and the transmitting contacts connected to the centre point of the coils associated with the A-wire, the centre point of the coils connected to the B-wire being earthed.

Currents from the line battery flow only in the A-wire, the B-wire acting as earthed screen. Interference from earth currents or from circuits in the same cable will cause currents to flow over both the A and B wires in the same direction. Provided that these currents are approximately equal, and in practice they are, the effect on the relay will be negligible, as the currents flow through the relay coils in opposite directions.

A smoothing filter is included in the transmitting network which cuts off the higher frequencies in the telegraph circuit (above 100 cycles per second) and consequently reduces interference to telephone circuits in the same cable.

Under rest conditions, the line batteries oppose and there is therefore no current in the line coils of the relays connected to the A-wire, signalling

being effected in the usual differential duplex manner.

The surge of current in the relay coil and line, produced when the transmitting contact reverses the battery at the transmitting end, also flows through the surge transformer and produces a correspondingly equal and opposite surge in the winding associated with the B-wire. Thus the interference produced in other circuits is reduced to a minimum owing to the fact that equal and opposite surge currents are produced in both the A and B wires.

In order to produce differentiability on the relays, the current through the two windings associated

with the balance network must be such that it produces equal and opposite effects to the line current flowing in one winding of the relay associated with the A-wire. The resistance in the balance network must therefore be twice the conductor resistance of the A-wire, that is, equal to the loop resistance of the circuit.

Twenty-volt batteries are used on the main lines (although forty volts are used for local ends described later) as the resistance required to limit the line current to 5 milliamperes is small. The larger resistance required to produce the same limitation with forty-volt batteries causes serious distortion to outgoing signals by retarding the charging current into the cable.

A modification of the circuit is shown in Fig. 2. It will be seen that the terminal apparatus remains unchanged, but that at one end of the circuit the A and B wires have been crossed. This results in the separation of the line batteries at each end of the circuit so that there is no incrementing or decrementing of the current, as in the original duplex case. Under these conditions one end of the circuit transmits over the A-wire and the other over the

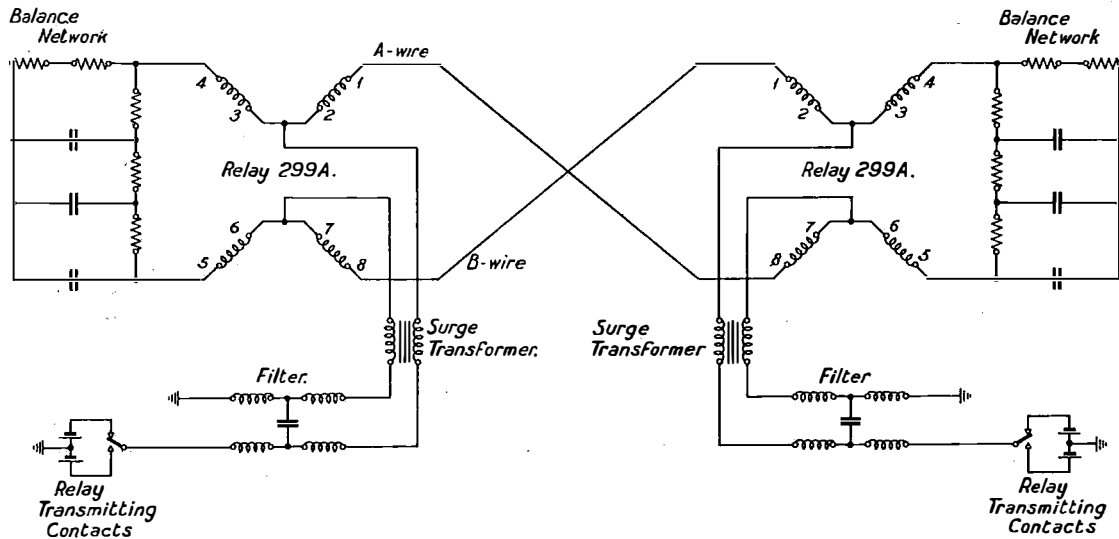

FIG. 2.—CROSSED DUPLEX.

B-wire, so that from the transmission point of view the circuit is a two-wire simplex arrangement.

This arrangement possesses several advantages over the normal duplex arrangements, particularly the removal of balance difficulties caused by the possible variable resistance of the transmitting contacts in the battery circuits and the fact that both the operating marking and spacing currents in the relays are currents from the distant end and have suffered the same characteristic distortion. In the duplex case, the spacing movement of the relay is produced by an incremented line current which is distorted by an amount depending upon the line constants, whilst the marking movement on the cessation of the incremented spacing current is produced by the constant current flowing in the balance circuit.

The current in each leg of the circuit shown in Fig. 2 is half that in the A-wire in the duplex case which is an advantage from an interference point of view.

The balance network and double differential relay are retained in order to protect the circuit against possible earth currents or interference from other circuits, the relays 299A being very sensitive.

Measurements of the distortion produced by the two arrangements have been made and on a London-Birmingham Birmingham-London circuit with repeater at Birmingham, comparative figures for distortion as measured from the renter's ends of the circuit are 30 per cent for the duplex and 16 per cent for the crossed duplex. These figures were obtained on Messrs. Standard Telephone & Cables, Ltd.'s distortion measuring set using the word "Paris" as the signal.

From Fig. 2 it will be seen that the direction of the currents in the operating coil of the relay are reversed as compared with those in the normal duplex arrangement shown in Fig. 1. When a repeater is included in the circuit, the signals come

out straight at the terminals due to the cross on each side of the repeater.

All repeated circuits are now using this crossed duplex arrangement. Later it is hoped to modify the relay connexions in all cases so that every circuit, repeated or not, can be worked crossed duplex.

For connecting the renters' apparatus to the main line terminals, circuits in the local telephone network are used. Voltages and currents are restricted to 40 volts and 20 milliamperes respectively.

Under Tariff A conditions it is necessary to provide a local record of the signals transmitted on the teleprinters at each end of the circuit, and with central battery working (central battery working being necessary on these circuits from economic

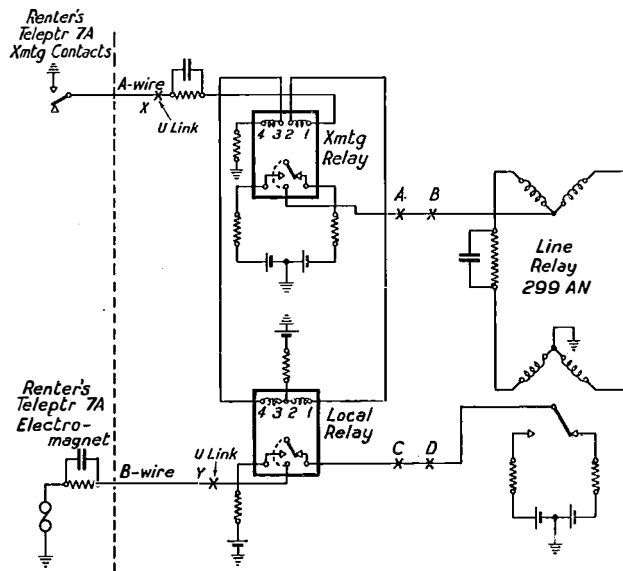

FIG. 3.—LOCAL LINE CONNEXIONS.

considerations) the obvious solution would be to use single current closed circuit working to give this local record. This, of course, would necessitate a spring bias on the teleprinter relay armature, but could not be adopted as it was desired that teleprinters used on Tariff A circuits should also be capable of being switched to Telex circuits, in order to permit of renters making the fullest possible use of the rented instruments. On Telex circuits, Double Current impulse working is used in the teleprinter electromagnet and for this reason spring bias could not be used for Tariff A teleprinters. Double current working on the teleprinter relay is therefore essential and the circuit shown in Fig. 3 has been adopted. Transmission from the renter is by means of single current over the A-wire

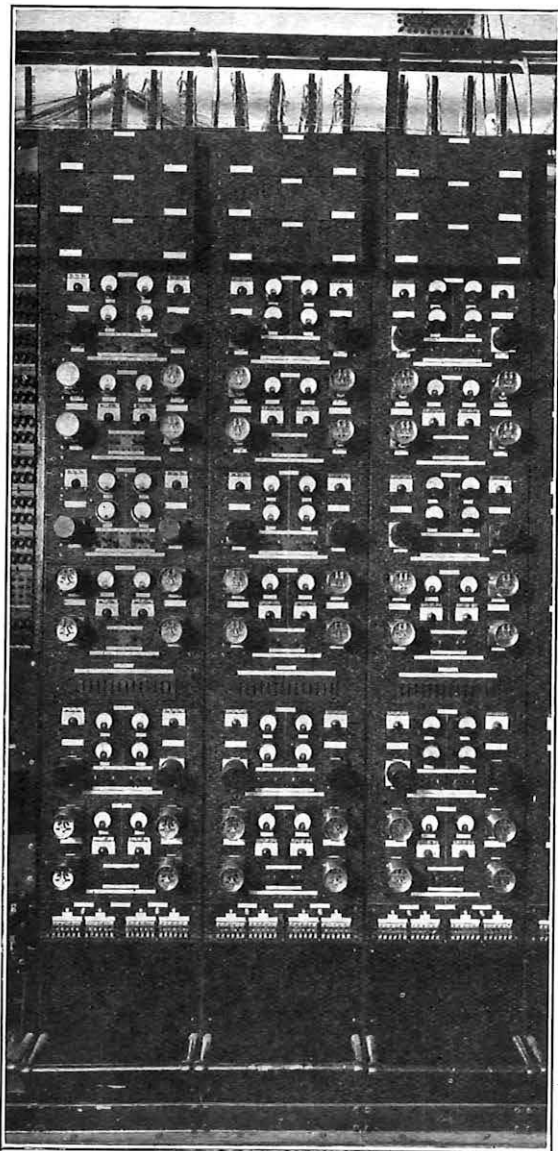

FIG. 4.—PANEL EQUIPMENT.

and for reception double current on the B-wire is used.

With the teleprinter transmitter tongue at rest (on marking stop) the A-wire is disconnected and the local and transmitting relays, the coils of which are in series are held to marking by the bias current flowing from the negative battery to the split of the transmitting relay, bias windings of the transmitting and local relays, to earth through the bias resistance. When the teleprinter tongue moves to space the A-wire is earthed and current flows via the split of the transmitting relay, transmitting relay line coil local relay line coils and A-wire to earth. Both relays move to space as the line current is greater than the bias current (the movement of these relays is accelerated by the signalling condenser at the terminal end of the line) and the transmitting relay repeats the signal on to the main line via the split of the line relay. The local relay tongue in moving to spacing picks up positive battery on its spacing stop and reverses the direction of the current normally flowing in the B-wire (negative from the marking stop of the main line receiving relay via marking stop of local relay). The single current signals made by the teleprinter are therefore repeated on to the main line and back to the transmitting teleprinter thus producing the necessary local record. In both cases the relays transmit double current signals.

Signals from the distant end of the main line operate the main line receiving relay and the receiving teleprinter from that relay's local circuit via the tongue and marking contact of the local relay. Double current working is again used.

It will be seen that mutilation of the signals will occur if the teleprinters at both ends of the circuit transmit at the same time owing to the operation of both the receiving and local relays by signals from the distant and local transmitters respectively. This permits of one station interrupting a transmission from the other when necessary.

The operation of the local and transmitting relays has proved satisfactory in practice in spite of the fact that the use of a constant bias current is not generally conducive to good working.

Shunted condensers and filters are used in both the A and B wires.

The operating conditions on all relays are such that neutrally adjusted relays can be used. The local and transmitting relays are of the Post Office Standard B type.

Vibrating conditions are provided on the 299 AN relays. The vibrating circuit can be switched on or off as required.

The equipment for these circuits, which is usually installed in telephone repeater stations, has been made up in panel form mounted on standard racks.

Standardization has been kept prominently in view in the design of the equipment and only three types of panels are used. These are—

- (1) The local line panel containing the local and transmitting relays and line equipment.

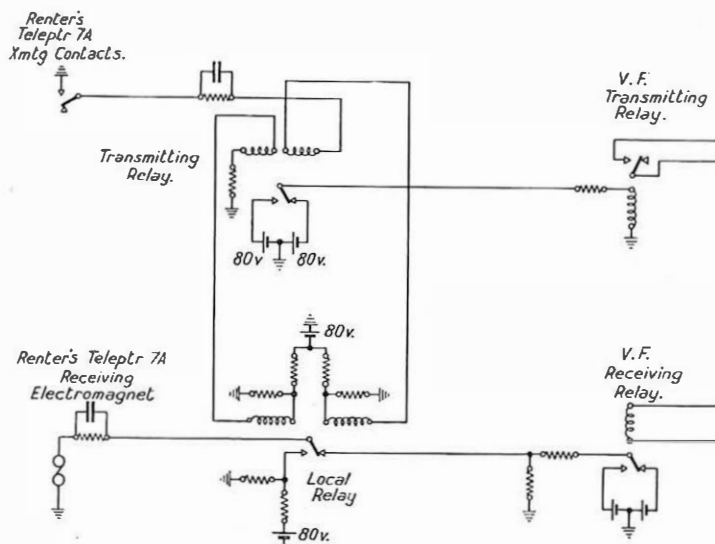

FIG. 5.—LOCAL LINE CONNEXIONS WITH MAIN LINE USING A V.F. CHANNEL.

- (2) The main line panel containing the main line receiving relays, transmitting filters, etc.
- (3) The balance panel.

The balance of these circuits is made up of fixed condensers and resistances and is permanently set up in the case of Tariff A circuits. As such circuits only work simplex, the accurate balance which is required for duplex working is not necessary and the fixed balances have been found to be quite satisfactory in practice.

In order to economise space, each panel contains equipment for two circuits.

For the termination of a circuit, therefore, half a local line panel, half a main line panel and half a balance panel are required; whilst a repeater is formed by one complete main line panel and one balance panel.

The arrangement of the equipment is shown in Fig. 4.

With the installation of multi-channel voice frequency sets, providing 18 circuits on one four-wire telephone circuit, it becomes necessary to utilize such channels on long distance circuits, to provide tariff A and B Private Wires. Fig. 5 shows the circuit adopted for connecting the local panels of the renter's circuit to a voice frequency

channel. The batteries used on the locals of the receiving relays on V.F. sets are standardized at 80 + 80 volts in order to meet public telegraph circuit requirements. To maintain this standardization, which permits the immediate changing of V.F. channels, the arrangements of the local end of the tariff A circuit have been slightly modified from those in use on by-product circuits. All 40-volt batteries are replaced by 80-volt batteries fitted with a potentiometer arrangement which gives the standard 40 volts on the local lines.

The equipment at a renter's office is the same in both cases and consists of a teleprinter, shunted condenser, and transmitting filter. These two latter are made up in a pressed steel case and mounted on a steel table provided by the Department. A photograph of the complete equipment is shown in Fig. 6.



FIG. 6.—RENTER'S EQUIPMENT.

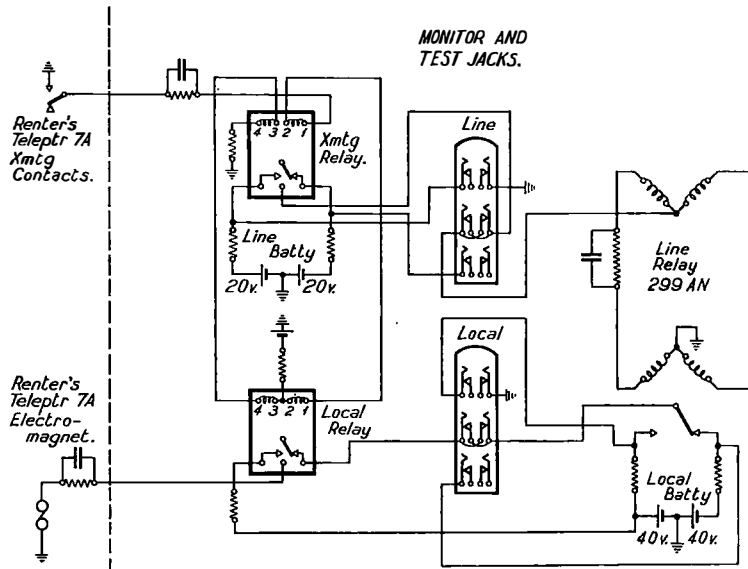

FIG. 7.—TARIFF "A" TERMINAL CIRCUIT, SHOWING POSITION OF MONITOR AND TEST JACKS (SCHEMATIC).

In the case of Tariff B circuits on by-products, the same line and local panels are used, but a variable duplex balance panel is used in place of the fixed balance to give the finer adjustment of balance required by the duplex working provided under Tariff B. In this type of circuit the local record cannot, of course, be used and the local line panel arrangements are such that the local record relay can be cut out by a switch, thus permitting any panel to be used for Tariff A or B circuits.

Full monitoring and testing facilities are provided at every terminal and repeater station, the arrangements being such as to ensure the quick localization of faults.

Each terminal station is provided with facilities for entering the circuit for :—

- (1) Monitoring outgoing and incoming signals.
- (2) Testing the circuit between the terminal equipment and the renter.
- (3) Testing the circuit between the home and distant terminal or repeater.

To meet the conditions of (1) it is only necessary to connect the monitoring teleprinter (or relay with monitoring teleprinter in local) in leak to either the tongue of the transmitting or main line receiving relay to monitor the transmitted or received signals respectively.

In the case of (2) it is necessary to cut the circuit at AB and CD (Fig. 3). The transmitting tongue of the monitoring teleprinter is then connected to C and the receiving electro-magnet or relay between A and earth.

The point D is left disconnected but negative line battery must be applied at B to hold the main line side of the circuit normal. In this case the monitoring teleprinter tongue is arranged to transmit double current to the local line.

In case (3) the tongue of the testing teleprinter must be connected to B and the electromagnet or relay between D and earth. A is left disconnected and negative local battery applied to C in order to hold the renter's teleprinter to marking (rest position).

In order to give the required facilities the points AB and CD (Fig. 3) are taken through the springs of jacks No. 49 arranged to "make" before

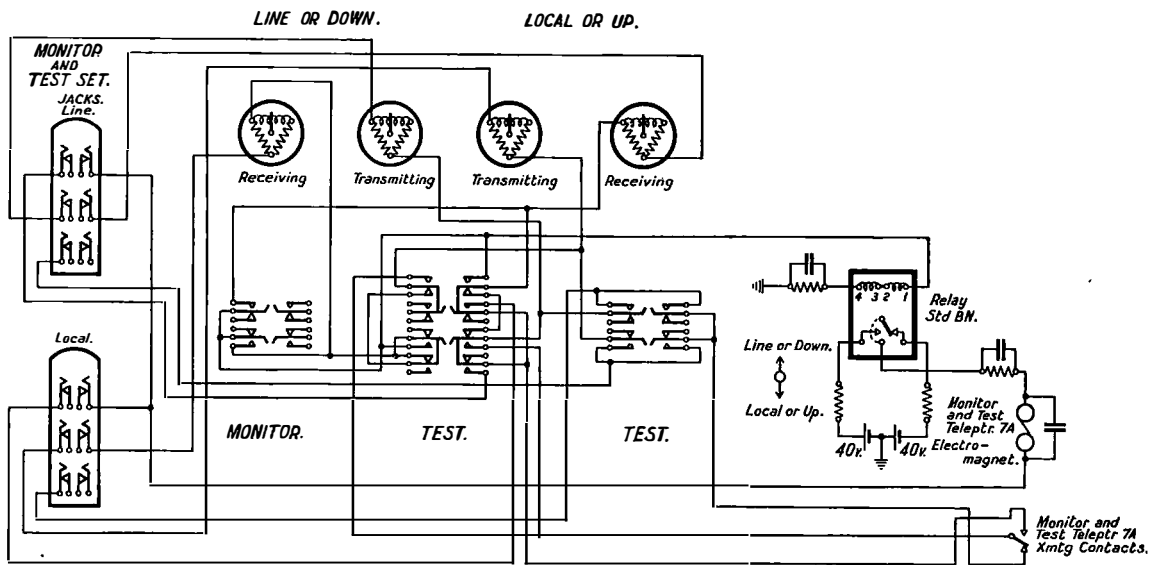

FIG. 8.—MONITOR AND TEST SET (SCHEMATIC).

A Simplified Carrier Telephone System for Open Lines

R. J. HALSEY, B.Sc., A.C.G.I., D.I.C.

Introduction.

THE art of carrier telephony is now a well developed one, and it is practicable to provide carrier telephone circuits of sufficiently good quality for any speech transmission system. The question of provision of such circuits is therefore a matter of economics and not of engineering difficulties. In America and on the Continent, there are available aerial lines of such length that the usual relatively high cost of carrier terminal apparatus is easily justifiable and moreover, these aerial lines are not likely to involve so many underground sections as aerial lines in this country. The effect of underground sections is twofold:—

1. The attenuation per mile is many times greater than that of open lines.
2. Owing to the impedance mismatch at the junctions of aerial and underground sections, considerable reflections are set up at carrier frequencies.

For use in this country, therefore, the conditions are doubly severe. In the first place, lines are short and in order to justify carrier working, the cost of terminal equipment must be low. In the second place, short aerial lines involving underground sections will have considerable attenuations at carrier frequencies and a fairly high terminal gain is essential.

To meet these requirements a single-channel system has been developed by the Research Section, incorporating a number of novel features, and it is anticipated that the relatively low cost of the equipment will be such as to make carrier working far more general, particularly at the outer fringes of the main telephone system. The new equipment, taking its power from the public supply mains, has the added advantage that it is eminently suitable for emergency and seasonal circuits, being easily installed and maintained; it will probably have considerable application in these fields.

General Principle of Operation.

The new system utilizes the same pair of wires and the same carrier frequency of 6,500 p.p.s. for the two directions of transmission, the carrier being practically suppressed and different sidebands being transmitted in the two directions. Thus, from the "Up" to the "Down" station the speech band of 200 to 2,500 p.p.s. is transmitted as 6,700 to 9,000 p.p.s. and from the "Down" to the "Up" station as 6,300 to 4,000 p.p.s. For proper operation the system therefore involves the transmission of frequencies up to 9,000 p.p.s. The normal speech channel (physical circuit) is free to transmit fre-

quencies up to 3,500 p.p.s., providing a direct current path and normal signalling facilities.

The carrier circuit is effectively a four-wire circuit between the terminal hybrid transformers and possesses all the normal properties of such a circuit. Thus, it may sing, with the exchange lines disconnected, if the overall transmission loss is reduced below about 2 decibels. To obviate this, the inner springs of the carrier exchange line jacks must be closed with 600-ohm resistance spools if a circuit with zero transmission equivalent is required. Signalling over the carrier circuit is accomplished by shifting the carrier frequency by 500 p.p.s. and between the two carrier exchange lines the circuit behaves exactly as if it actually transmitted 17 p.p.s. ringing current. It is not at present practicable to provide junction signalling facilities and so all carrier circuits must be operated on a trunk ringing basis, with generator calling and clearing.

Mounting of Equipment.

The complete equipment is mounted on three panels to fit ordinary repeater racks, the rack space occupied being as follows:—

Panel No. 1A, Power panel for A.C. supply mains	}	7 ins.
or No. 1B, Power panel for D.C. supply mains		
Panel No. 2, Transmitter, receiver and ringer		8 $\frac{3}{4}$ ins.
Panel No. 3, Filters		7 ins.
Total rack space—1 ft. 10 $\frac{3}{4}$ ins.		

Where suitable racks are not in existence it is proposed to mount the equipment in one of two ways:—

1. On special racks about 4 ft. 6 ins. in height, standing on the floor. Two such racks are shown in Figs. 1 and 2.
2. In metal cabinets with internal racks. Such cabinets would stand on any convenient table.

The following leads are necessary for the installation of the equipment:—

1. Aerial line pair;
2. Physical circuit exchange pair;
3. Carrier circuit exchange pair;
4. Lighting or power supply;
5. 17 p.p.s. ringer (if available);
6. Earth (to panels).

Screened leads are not necessary, but the power leads should not be laced in with the other pairs. Where a 17 p.p.s. ringer is not available, the calling relays can be operated with direct current from the power panel.

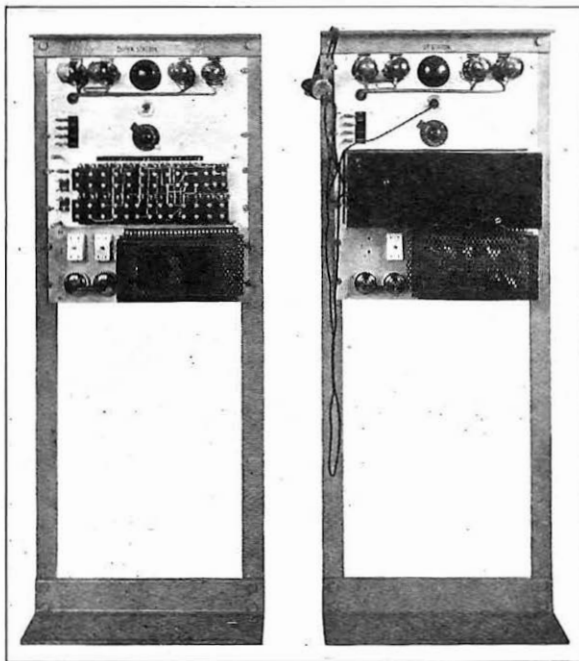

FIG. 1.—FRONT VIEW OF EXPERIMENTAL EQUIPMENT.

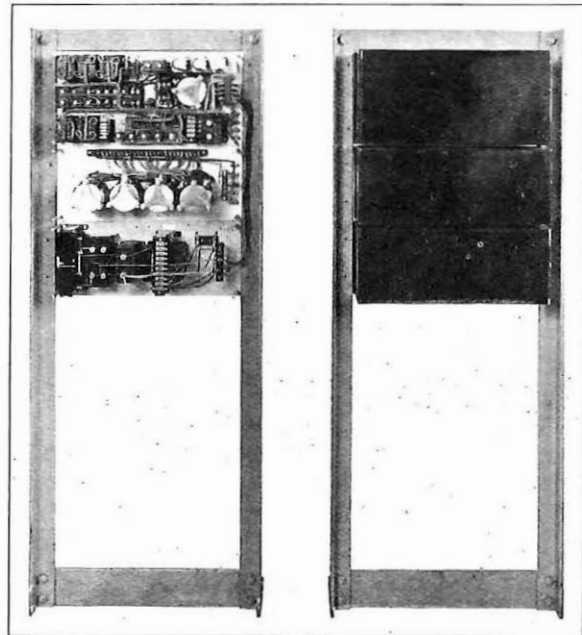

FIG. 2.—REAR VIEW OF EXPERIMENTAL EQUIPMENT.

Panel No. 1A—A.C. Power Panel.

This is required to provide power as follows :—

- (a) 1 amp at 16 volts, to four valve heaters in series. A 1-ohm resistance is included in this circuit for purposes of current measurement, and the voltage across this is adjusted to 1 volt by means of alternative transformer tapings.
- (b) Anode current at 150 volts to

Transmitter valve	20 mA.
Receiver	„	...	15 mA.
Ringer	„	...	15 mA.
Oscillator	„	...	5 mA.
Total anode current =			55 mA.

In addition, the following currents may be taken while ringing :—

- Relay C 1.5 mA.
- D.C. to exchange line (in certain cases) 15 mA.

The anode voltage is derived from a Westinghouse metal rectifier and passes through a two-stage smoothing unit. The total power taken from the mains is about 40 watts and any of the usual supply voltages are suitable.

Panel No. 1B—D.C. Power Panel.

This is required to provide power as follows :—

- (a) 250 mA. at 64 volts, to four valve heaters in series. A series 4-ohm resistance is provided for checking the heater current, but no adjustment is necessary apart from connexion being made to the appropriate mains voltage tapping. Any of the usual supply voltages are suitable.

- (b) Anode current at 150 volts exactly as in the case of the A.C. power panel. The anode current is derived from a potentiometer across the mains, both legs being smoothed. The -ve main is earthed through a 4 μF condenser, but either main may be at D.C. earth potential. Only supply voltages of 200 volts or more are suitable for high tension supply, and where the voltage is lower, other provision must be made; such cases are, however, very rare. The total current taken from the mains is about 370 milliamps, the power being 92 watts at 250 volts.

Panel No. 2—Transmitter, Receiver and Ringer Panel.

The valve equipment is all mounted on one panel which is not altered in any way, whether the A.C. or D.C. power panel is used. The valves employed are, however, different in the two cases. The following table refers to valves of the Osram series :—

Position.	A.C. Case.			D. C. Case.		
	Type.	μ	R ₀	Type.	μ	R ₀
Transmitter	ML ₄	} 12	2,860	DL	} 12	2,660
Receiver	ML ₄			DL		
Ringer	ML ₄			DL		
Oscillator	MHL ₄	20	8,000	DH	40	10,800

Oscillator.

The oscillator is of high quality, employing a dust-cored inductance for tuning and coupling, the grid and plate windings being each 30 mH. A fixed feed back resistance of 200,000 ohms is used to give stability and freedom from harmonics, and the valve works into a fixed impedance of 10,000Ω. It supplies carrier frequency to the grid circuits of the transmitter and receiver valves. The feed to the transmitter is required to be about 5 volts and is adjusted by means of soldered taps. The feed to the receiver is fixed at 0.6 times that to the transmitter, *i. e.*, about 3 volts. When a ring is transmitted, the sending end oscillator frequency is changed by 500 p.p.s., being increased in the case of the "Up" station transmitter and decreased in the case of the "Down" station transmitter. This is done by means of small subsidiary tuning condensers associated with the contacts of relay A. The oscillator frequency is continuously variable over a range of about 80 p.p.s., this giving ample range of adjustment. It is desirable that the carrier frequencies at the two ends of the circuit shall be within 20 p.p.s. of the nominal 6,500 p.p.s. and within 5 p.p.s. of each other. There is no difficulty in maintaining this adjustment, as the oscillators are very stable in operation.

Transmitter.

An entirely new method of modulation is incorporated in the transmitter which consists of an amplifier, handling speech and carrier frequencies simultaneously, the output transformer being shunted with a metal rectifier. For the simplest conception of the action of the transmitter, if the two sources (of speech and carrier) are applied in series to the grid of a valve, without overloading it, these will be amplified together and will both appear at the output transformer. If now a metal rectifier is shunted across the secondary of this transformer, in parallel with the load impedance, a modulated wave will be generated, since each alternate half cycle will be short-circuited. This is shown in Fig. 3. Actually this can be improved upon, and the grid voltage may be allowed to overload the valve at the lower end, provided that the polarity of the rectifier is correct. Maximum output and efficiency can be obtained if the following conditions are observed:—

1. The valve is biased by a condenser and leak in its grid circuit. This circuit has a time constant of 0.1 secs. and allows grid current to flow to the extent of 0.1 microamps per volt or about 1 microamp maximum.
2. The rectifier has a sufficient number of series elements to prevent rectification taking place until the forward voltage is about 1 to 2 volts. The optimum number of elements is about 18.
3. The R.M.S. carrier voltage across the rectifier is rather greater than the greatest R.M.S. speech voltage which the circuit is designed to transmit. As a compromise, this is taken as corresponding to 4 milliwatts at the exchange line.

The various products of modulation pass into the filters and the appropriate sideband is selected therein. In the modulator output circuit is a 200Ω resistance spool. This must be in circuit in the case of the "Down" station transmitter, otherwise the filter impedance presented to the rectifier at certain speech frequencies falls unduly low and modulation is impaired. The resistance is, however, not necessary in the case of the "Up" station transmitter. The normal sideband levels to line are approximately +5 db. at the "Up" station and +4 db. at the "Down" station.

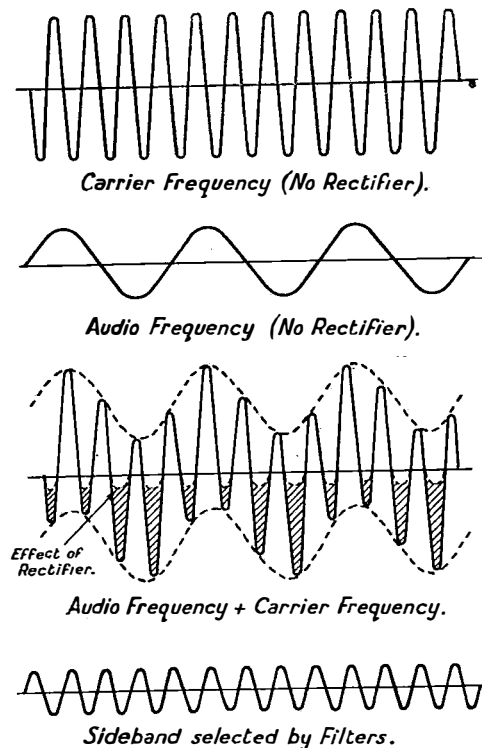

FIG. 3.—ACTION OF METAL RECTIFIER AS A MODULATOR.

Receiver.

The operation of the receiver is somewhat similar to that of the transmitter. In this case, however, the valve is biased by means of a resistance in the cathode lead, and the grid is never overloaded. The received sideband and local carrier are amplified together in the valve and two series-connected metal rectifiers act as full wave demodulators, the resultant speech being passed by the low-pass filter section in the output circuit. This filter passes frequencies up to 2,600 p.p.s. and its attenuation is a maximum (about 50 db.) at 6,500 p.p.s. The high frequency leak past this filter is of the order of 0.02 volts and is chiefly 13,000 p.p.s. This is just perceptible at the carrier terminal, but is subsequently lost or is masked by exchange noises.

The design impedance at the demodulator output is 300 ohms and this is matched against a nominal

600-ohm exchange line through the differential input transformer. The demodulator can be worked at an output level of +4 db., corresponding to a circuit of zero equivalent overall. It is important to note that a path has to be provided for the D.C. component from the rectifiers; this is done *via* the 600-ohm balance resistance which is permanently incorporated in the equipment.

Ringling.

When ringer is applied to the exchange line at the switchroom, it operates relay A (Fig. 4). This is a D.C. relay shunted with a metal rectifier and operates with about 30 volts of 17 p.p.s. When this relay operates (it can only do so if there is no incoming ring) it

The ringling receiver is of a type which has been developed by the Research Section for more general purposes and its action is as follows:—

1. Relay B is designed so that it does not operate until the sum of the currents in its two windings is 30 mA. It releases when the sum falls to 20 mA.
2. With no incoming signal, the current through one winding (the anode current of the valve) is adjusted by means of the automatic biasing resistances to be 15 mA. ± 0.5 mA. The current in the second winding is now zero and the relay does not operate.
3. When a 500 p.p.s. signal of good wave form is impressed on the grid of the valve, the anode current is hardly affected over a very wide

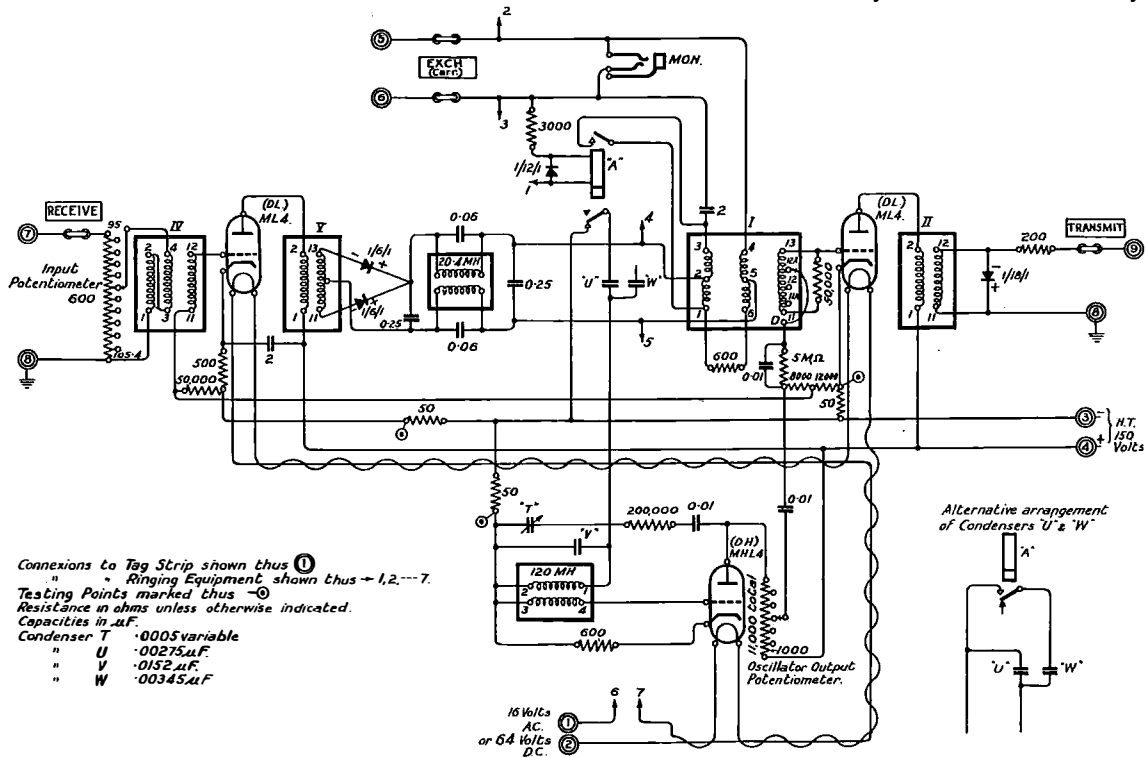
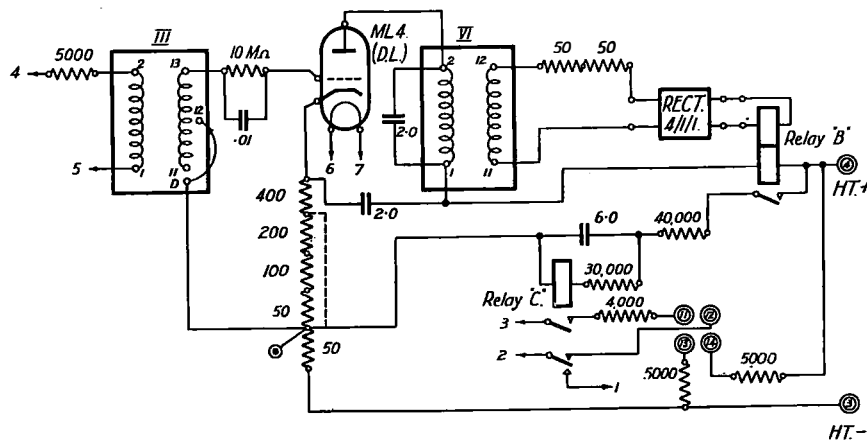

FIG. 4.—MODULATOR AND DEMODULATOR.

1. Short-circuits one winding of the differential input transformer and so effectively prevents overloading of the transmitter valve with 17 p.p.s.
2. Either increases or decreases the carrier frequency by 500 ± 15 p.p.s., depending on whether the transmitter is at the "Up" or "Down" station. As a result, a continuous tone of either 7,000 or 6,000 p.p.s. is transmitted over the line, and this is demodulated against the local carrier (6,500 p.p.s.) at the receiving end. The resultant 500 p.p.s. tone, like all demodulation products, is applied to the ringer valve (Fig. 5).

range of inputs, since the average anode current approximates to the static value. This is entirely a function of the form factor of the signal as the grid bias will depend on the peak value of the grid swing, which charges the biasing condenser.

The 500 p.p.s. signal is also amplified by the valve; picked up across a tuned circuit in the anode path, rectified by a bridge-connected metal rectifier and applied to the second winding. This causes sufficient current to flow in the relay winding to operate the relay. When relay B operates it operates relay C, through a delay network, after about 500



Connexions to Tag Strip shown thus ⊙
 Connexions to Modulator - Demodulator Equipment shown thus → 1,2.....7.
 Testing Point shown thus ⊙
 Resistances in Ohms unless otherwise indicated.
 Capacities in μF.

FIG. 5.—RINGER.

milliseconds. A momentary flicker of relay B is therefore insufficient to operate relay C. When relay C is operated it performs two functions—

- (a) Disconnects the sending relay A;
 - (b) Applies the local 17 p.p.s. ringer to the carrier exchange line. If no local ringer is available, direct current from the power panel can be substituted to operate the calling relay.
4. When any signal other than pure 500 p.p.s. tone is applied to the ringer, the anode current in the first relay winding falls in accordance with the principle previously outlined, and even if the rectified current in the second winding is maintained at 15 mA., the relay cannot operate. The 15 mA. required in the second winding cannot possibly be obtained by speech and the maximum current obtainable with pure 500 p.p.s. tone is about 17 mA.

In practice, reliable ringing is obtained on circuits with overall transmission equivalents up to 10 db. In all cases false operation of the ringing by speech currents or battery impulses is sensibly impossible.

Panel No. 3—Filters.

The filters for the “ Up ” and “ Down ” stations are identical. The connexions to transmitter and receiver are, however, interchanged in the two cases. The circuit diagram is shown in Fig. 6. The three frequency bands formed by the filters are:—

- (1) 0-3,500 p.p.s. for physical circuit;
- (2) 3,800-6,450 p.p.s. for carrier L.S.B.;
- (3) 6,650-9,000 p.p.s. for carrier U.S.B.

The inductances are all wound on minor circuit loading coil cores and have dissipation constants $d = R/\omega L$ of the order 0.006 at frequencies from

2,000 to 9,000 p.p.s. Below 2,000 p.p.s. this figure increases somewhat, but the losses are always low. The manufacturing tolerance is $\pm 1\%$. The transmission losses for the filters at each end are shown in Fig. 7, from which it will be seen that the losses to the carrier frequency is about $22\frac{1}{2}$ db. per end. The specified loss is 20 to 25 decibels and this is obtained by the limited adjustment of a particular filter condenser, if necessary. This suppression occurs at both the transmitting and receiving terminals and the difference between the levels of the local and received carrier frequencies at the demodulator is therefore between 40 and 50 db. This difference is adequate for the system.

Overall Gain of System.

For normal use the input transformer tapping is 12, but alternatives are provided as follows:—

- 1. Tap 12A gives a transmitter gain and output 3 db. below tap 12. This is designed for use in cases where it is desirable to handle larger input volumes;
- 2. Taps 11A and 11 give increased transmitter gains (3 db. and 6 db. respectively), and may be used to make up the losses in two-wire extensions.

The input transformer of the receiver is designed to give a step up of 1 to 20 at the “ Down ” station and 1 to 10 at the “ Up ” station. The difference is obtained by using the two primary windings in series for the L.S.B. receiver and one only for the U.S.B. receiver. This fits in well with the usual requirements, but if necessary the full 1 to 20 steps up may be used at the “ Up ” station with only a slight loss of quality. The maximum gains obtained with the experimental models, transmitters on tap 12, are as follows (at 800 p.p.s.)—

- “ Down ” to “ Up ” stations, step up 1 to 10
 20 db.
- “ Up ” to “ Down ” stations, step up 1 to 20
 28 db.

Typical gain-frequency curves are shown in Fig. 8.

Installation of Equipment.

The installation of the carrier terminal equipment is not a difficult matter and it is expected that the work will eventually be carried out by Departmental staff. Stations will be allocated equipment suitable for “ Up ” or “ Down ” station terminals after taking into account any similar carrier systems operating over the same pole route. It is highly desirable, from the point of view of cross-talk, that

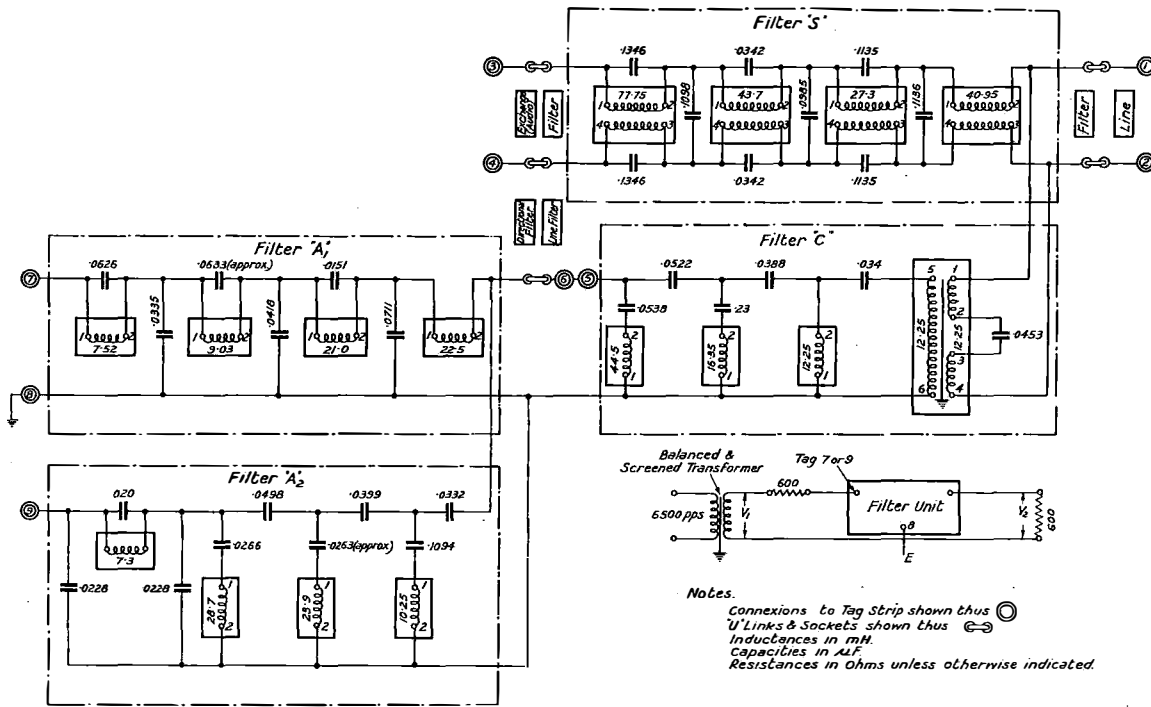
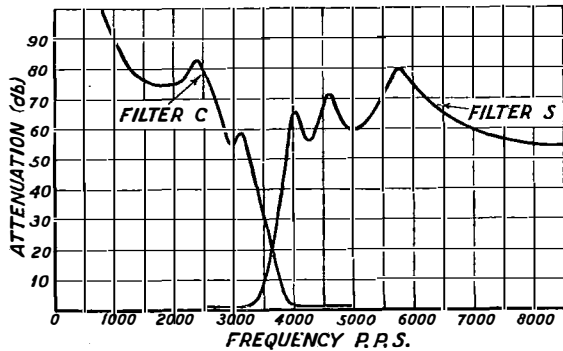
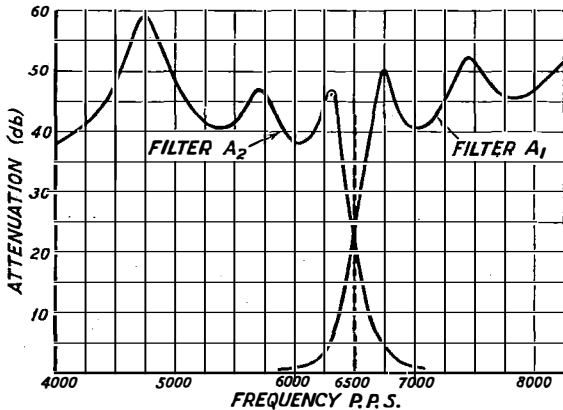

FIG. 6.—FILTERS.



Attenuation Characteristics of Line Filters.



Attenuation Characteristics of Directional Filters.

FIG. 7.—FILTER CURVES.

similar frequency bands should be transmitted in the same directions.

With the equipment in position, and appropriate panel wiring completed, the following checks are required at the two ends independently:—

1. Check heater current (and adjust in the case of an A.C. supply) by measuring the voltage drop across the series resistance provided.
2. Check the carrier frequency by comparison with the nearest repeater station oscillator. All available oscillators will be given a special calibration at 1,625 p.p.s. (the fourth subharmonic of the carrier frequency) and if this frequency is applied to the carrier exchange line, beats will be heard by listening between the "Transmit" U-link and panel. The variable condenser can then be adjusted until a slow beat is obtained. Alternatively, a simple wavemeter may be provided.
3. Remove the "Transmit" U-link and close the transmitter with 600Ω and rectifier voltmeter 0-10 volts. The carrier output should then be about 3.2 volts at the "Up" station and about 2.8 volts at the "Down" station, and should be adjusted if necessary by means of the carrier feed potentiometer. Working limits will be determined from the contractor-made equipment.
4. Measure all anode currents. This can be done by means of a D.C. voltmeter across the 50-ohm spools provided in each anode circuit, or with a low resistance milliammeter across the same points. The ringer anode current should

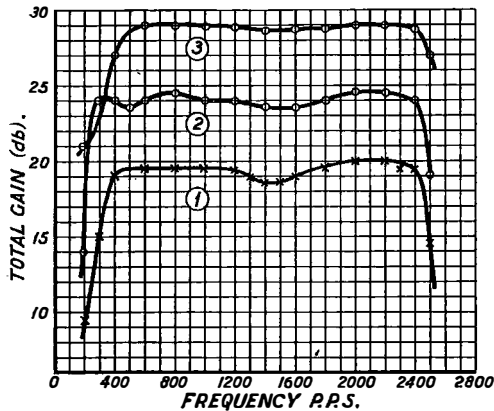

Curve 1—Down to Up Station; Input Transformer tap 12, Receiver Input 1—10 Step Up.
 Curve 2—As Curve 1, but Receiver Input 1—20 Step Up.
 Curve 3—Up to Down Station; Input Transformer tap 12, Receiver Input 1—20 Step Up.

FIG. 8.—GAIN-FREQUENCY CURVES.

be adjusted to 15 mA. \pm 0.5 mA. by means of the biasing resistances.

The circuit should then be lined up in the two directions. To do this, the carrier exchange lines are closed with 600 ohms and rectifier voltmeter, the receiver input potentiometers being set to minimum gain. The "Down" station relay A is then operated by hand and the potentiometer at the "Up" station is turned up until the meter reads a value corresponding to the overall transmission loss required, a suitable calibration being provided. The other direction is then lined up in the same manner. If the circuit is intended to be better than 3 or 4 decibels overall, 600-ohm resistances should be connected across the inner springs of the exchange line jacks. In certain cases, for example a line involving bad reflections, the above method may not be entirely satisfactory as the circuit may sing when the apparent loss is greater than 3 db. In such a case, the singing condition with the exchange lines disconnected should be taken as the criterion of the maximum gain. When singing occurs it is of an intermittent nature, beating at the difference between the two carrier frequencies. Equality between the two carriers is thus readily checked.

Maintenance of Equipment.

With the limited experience available it does not appear to be necessary to recommend daily maintenance testing. A repetition of the installation checks once a week appears to be adequate, but it will be necessary to apply the results of subsequent experience in this connexion.

It is anticipated that the life of the valves employed will be of the order of 5,000 to 10,000 hours. Where circuits are installed for considerable periods, a record of the tests will be kept and these should quickly reveal the necessity for changes of valves.

Provision is made for talking on the two-wire

exchange line by means of a monitor jack. Any local battery telephone may be used for this purpose, but, for occasional monitoring, high impedance head-gear receivers are desirable. Ringing between the carrier terminals can be accomplished with a hand generator from either the monitor jack or the carrier exchange line U-links. Alternatively relay A may be hand operated.

Valves.

Owing to the fact that indirectly heated A.C. valves are designed to operate on a voltage and not on a current basis, special selection by the manufacturer will be necessary to ensure that four valves will work satisfactorily in series. This will not be difficult as it is not proposed to insist on very close limits for the valve characteristics. The indirectly heated D.C. valves are designed to operate on a current basis and do not need special selection for heater characteristics.

Random changes of valves in the transmitter and receiver positions show that a variation of about 1 db. in each position may be anticipated (*i.e.*, a maximum of 2 db. variation in the gain due to valve changes). Similar changes in the oscillator valve do not perceptibly affect the gain. The ringer valve is particularly insensitive to changes of valves as, owing to the automatic biasing, the emission tends to be self-correcting.

Effect of Carrier Equipment on Existing Physical Circuit.

The introduction of the carrier equipment introduces a small loss into the existing circuit. This loss amounts to about 0.15 db. per end at 1,000 p.p.s., 0.2 db. per end at 2,000 p.p.s. and 0.5 db. per end at 3,000 p.p.s. Cross-talk between the carrier circuit and its associated physical circuit is of the order of 60 db. on full gain; this is adequate for the system.

Several Carrier Systems on the same Pole Route.

When two or more systems are operated on the same pole route, there is the potential difficulty of cross-talk between them. In practice this is not likely to prove serious with the present system provided that the following points are observed in installing:—

1. Similar frequency bands should operate in the same direction over the pole route.
2. Where possible, the pairs concerned should be widely separated. Where wires are run in twisted squares, two carrier circuits are often better in the same square than in adjacent squares. Pairs in underground sections should be widely separated.
3. Where either of the pairs concerned is, by nature of its associated circuit, liable to have a full D.C. earth on one wire (such a case is an R.A.X. junction) chokes and condensers should be introduced to balance the circuit to speech and carrier frequencies.

If excessive cross-talk occurs after these points have been attended to, it can be cured by frequent transpositions. A single transposition near the middle of a circuit is sometimes useful. Before making such transpositions, however, the balance and insulation of the pairs should be carefully verified.

Other Interferences.

These may be classified under the following headings :—

1. Interference with programme circuits.

This is not serious as the steady carrier frequency is at a very low level. Sideband frequencies are generated down to 4,000 p.p.s., but the volume at frequencies below 5,000 p.p.s. is small. Nevertheless, carrier circuits should be separated as far as possible from circuits frequently used by the B.B.C.

2. Interference from radio stations.

The only stations which can conceivably cause interference are long wave telegraph transmitters. A filter is provided to eliminate these signals and even Rugby (GBR), which causes so much trouble at higher frequencies, should always be inaudible.

3. Interference from power lines.

The carrier system is very free from power interference even on those lines on which the physical circuits usually suffer.

4. Noises due to line faults.

The type of interference is similar to that experienced on physical circuits, though usually less severe. Line unbalance, due to contacts, broken insulators, etc., may seriously increase cross-talk between two carrier systems on the same pole route. For this reason the line should be maintained in good condition.

5. Telegraph interference.

Line cross-talk from telegraph circuits is negligible.

Effect of Weather.

High frequency carrier systems, particularly on long lines are subject to considerable changes of

attenuation due to weather conditions, fog and salt spray being particularly bad and frequent causes of losses. The present system is, however, scarcely affected in this respect as the frequencies are low and the lines comparatively short.

Typical Line Characteristics.

The lengths of open line over which the system can be operated with a transmission equivalent of 5 db. overall are approximately as follows :—

150-lb. copper	370 miles
200-lb. copper	400 "
300-lb. copper	470 "
400-lb. copper	550 "

The limiting lengths of unloaded underground conductors are approximately :—

20-lb. A.S.P.C.	14 miles
40-lb. A.S.P.C.	26 "
100-lb. A.S.P.C.	50 "

Where the whole of the circuit is unloaded U.G. cable, it is desirable to introduce transformers or auto-transformers between the carrier terminal equipment and the line. A suitable impedance ratio is 4 : 1, the line winding being the lower impedance.

A typical route over which the system may be required to work is London-Salisbury. This consists of 86 miles of open line of mixed gauge (chiefly 200-lb. copper) and 7.7 miles of unloaded underground cable. A "zero" circuit has been provided on this line, comparing with a physical circuit attenuation of 11 db. at 1,000 p.p.s.

Use as an Emergency Circuit.

An excellent opportunity to demonstrate the use of the equipment for emergency circuits occurred during the recent attempt on the waterspeed record by Mr. Kaye Don at Loch Lomond. In this case the equipment was used to provide a Press circuit over the Luss-Helensburgh R.A.X. junction. This circuit was extended to the Glasgow Trunk Switchboard and provided excellent facilities. Other carrier circuits were also used on the same route, but everyone concerned with the circuits can testify to the enormous superiority of the new equipment.

Inductive Interference from Fault Currents on E.H.T. Power Lines

A. J. JACKMAN, B.Sc., A.C.G.I., A.M.I.E.E.

THE rapid expansion, in the last few years, of a network of E.H.T. power transmission lines throughout the industrial areas of Great Britain has introduced problems for communications engineers in connection with the possibilities of interference from these power lines with the operation of telephoné and telegraph circuits. A very

useful summary of the chief theoretical studies of these problems published prior to 1925 is given in the Journal of the Institution of Electrical Engineers, Vol. 68, pp. 587-641 (1930), and the summary is completed up to 1930 in a further paper by W. G. Radley, B.Sc., in the J.I.E.E., Vol. 69, pp. 1117-1148 (1931).

The available knowledge of the subject has been extended by further tests made by the Electrical Research Association (E.R.A.) and the G.P.O. Research Section in the district between Lancaster and Carlisle in Nov.-Dec., 1931, and in Oct., 1932, and at Eltham (S.E. London) in Dec., 1931, and January, 1932. An account of the results of these experiments will be published in due course.

The power lines from which inductive interference may be anticipated are those overhead lines working at 11 kv, 33 kv, 66 kv and 132 kv. The 11 kv lines do not provide very many cases requiring serious consideration because of their relatively low voltage and also of their short length.

Overhead lines of 33 kv and 66 kv are being erected by the Central Electricity Board (C.E.B.) and also by other Undertakings. Lines of 132 kv have been erected, so far, only by the C.E.B. and the Grampian Electricity Supply Company. Certain of these lines are sixty miles in length, and in many cases they are roughly parallel with communication routes for the whole of their length.

There are also underground power cables working at 33 kv, 66 kv and 132 kv, and these must be considered as possible sources of inductive interference.

The 132 kv lines of the Grid System provide the most serious problems because of their high voltage, long length of parallelism, and also because in each transformer Sub-Station the neutral point of the Star-winding on the high tension side of the transformer is directly earthed. This is a departure from the Regulations made by the Electricity Commissioners under the Electricity (Supply) Acts, 1882-1928 et seq., since these Regulations specify that an F.H.T. circuit may not be connected with earth at more than one point. The departure was agreed after consultations between the Electricity Commissioners, the C.E.B. and the G.P.O. Engineering Department. The advantages claimed for this were—

- (1) It makes possible the use of selective protective apparatus very rapid and certain in its action, resulting in the elimination of a fault current in a minimum time.
- (2) It increases the reliability of the system since the neutral point is definitely fixed at earth potential.
- (3) The risk of simultaneous faults on different phases is eliminated. With an unearthed system a failure of the insulation at a point on one phase raises the *p.d.* between the other two phases and earth to the phase-to-phase voltage as against the phase voltage only. This may result in breakdown of the insulation at one or more points on these two phases and very large currents might flow through the earth between the fault points.
- (4) It permits also a cheaper design of transformer, the insulation being graded towards the neutral point, since this point is always at earth potential and will never attain phase-potential, as it might do on the un-earthed system.

A description of the Grid System is given in a paper by Messrs. Johnstone Wright and C. W. Marshall, published in the J.I.E.E., Vol. 67, pp. 685-723 (1929).

The telephone lines which are subject to inductive interference are usually trunk and main telegraph lines which are paralleled by a power line for a considerable distance. Both overhead and underground routes require to be considered. The latter are, of course, shielded by the lead sheath of the cable.

Inductive interference from a power line on an adjacent parallel communication circuit arises from electrostatic influences (Electric Induction) and electromagnetic influences (Magnetic Induction).

The electrostatic effects can be computed by mathematical treatment, and reference to the most important formulæ will be found in part one of the Summary of Information referred to above.

Electrostatic effects, and mechanical considerations led to a decision that all Post Office overhead routes should be placed underground at crossings by 132 kv lines. The length of the section put underground is such that the minimum horizontal separation between overhead power line and overhead communication line is not less than the height above ground-level of the highest wire on the power line measured at the tower. Apart from this the electrostatic effects are not considered to necessitate separate protective treatment.

The electromagnetic effects are a much more serious problem in a system worked with an earthed neutral point, and these effects are very difficult to deal with both as regards theoretical studies and as regards the application of practical protective measures.

The load currents flowing in the three phases of a transmission line will produce a magnetic field, but if the loads on the phases are balanced the load currents will be equal and at 120° phase displacement and the resultant magnetic field at any external point will be very small. Transposition of the power conductors reduces the interference which might be caused by the load currents and by harmonics other than the 3rd and odd multiples of the 3rd harmonic. In the latter case the interference produced is in the nature of a humming noise in the telephone receivers, and can be overcome by transposing and balancing the telephone circuits affected.

If, however, one phase of a transmission line develops a fault to earth there will be a very heavy flow of current along this conductor, and back through the earth to the transformer. This current is not balanced by currents of similar magnitude on the other phases and its magnetic field will therefore have very considerable intensity. This magnetic field will result in a longitudinal e.m.f. being induced in a parallel electric circuit. In particular a very considerable e.m.f. might be induced between a parallel communication circuit and earth, giving a risk of false operation of indicators, damage to plant, acoustic shock to operators, or even electric shock to operators or to workmen working on the line,

according to the magnitude of the induced voltage.

The mathematical treatment is very complex and the formulæ proposed, can only be applied in connection with values of average earth resistivity either entirely hypothetical or deduced from the results of experiments in the locality concerned. Since values of earth resistivity measured in the vicinity of power lines in England have varied between 1000 ohms per cm. cube at Runcorn and 230,000 ohms per cm. cube at Shap, Cumberland, and, moreover, widely differing resistivities might be met between the two ends of one power line, it is apparent that no mathematical

treatment can give a close estimation of the degree of danger unless it is based either on measured values of earth resistivity in the locality or on geological data from which an approximate earth resistivity may be assumed.

Curves are given in Fig. 1 showing the mutual induction in Henries $\times 10^{-4}$ per Km between two parallel overhead circuits with earth return, for these two resistivities, calculated according to the formula now applied. The importance of the resistivity factor is evident.

The Comité Consultatif Internationale (C.C.I.) in

MUTUAL INDUCTION BETWEEN POWER & TELEPHONE LINES AT VARIOUS EARTH RESISTIVITIES

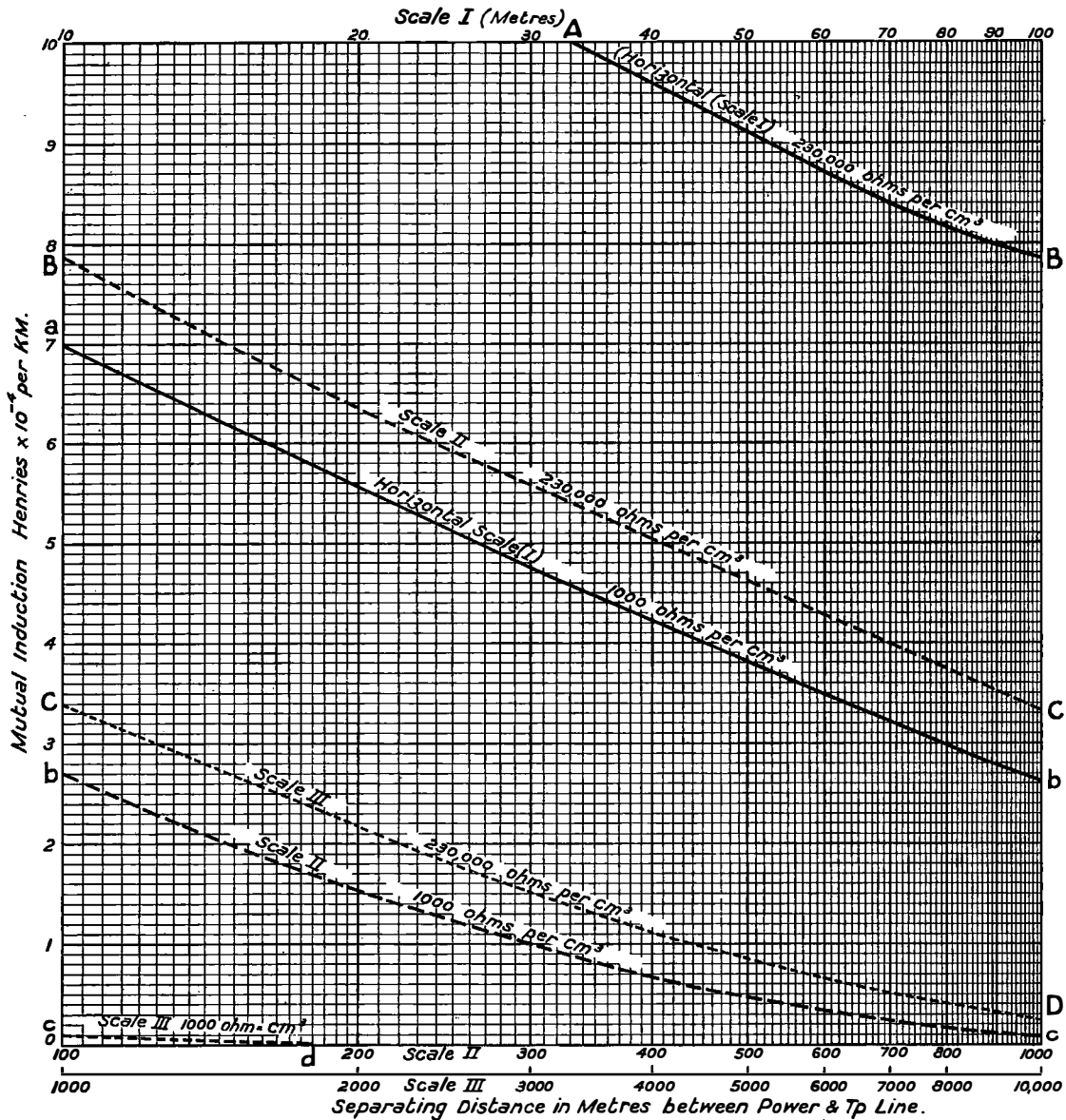

FIG. 1.

1925 recommended the adoption of a formulæ derived by R. Rüdberg, used with an assumed earth resistivity of 20,000 ohms per cm. cube. This recommendation was adopted by the G.P.O. until 1929.

As a result of research in many places the C.C.I. in 1929 recommended the adoption of a formula derived by Pollaczek, and also the use of an assumed average earth resistivity of 4700 ohms per cm. cube, when no definite information regarding the actual resistivity was available. The formula of Pollaczek gives practically the same results as formulæ derived by Carson in the U.S.A. Further details of the three formulæ will be found in the Summary prepared by W. G. Radley, already referred to.

The results obtained from the three formulæ do not differ very materially when small separating distances and medium values of earth resistivity are considered, but the Rüdberg formula gives values which are too small when the separating distance is great or the resistivity of the soil is low. This was the reason why it was abandoned. The formula of Pollaczek is now in use. The formula is

$$M = -\frac{4}{k^2 x^2} + 4 \frac{kei'(|kx|) - jker'(|kx|)}{|kx|}$$

where x = horizontal separating distance

$$k = \sqrt{4\pi\sigma \cdot \omega}$$

and kei' ker' are functions given in tables in the British Association Report of 1915.

An elementary conception of the inductive interference between a straight power line with an earth fault on one phase, and a parallel communications circuit may be obtained, in non-mathematical terms as follows:—

When an earth-fault occurs on one phase of a power line in a system working with an earthed neutral point, a fault current will flow outwards along the phase wires to the fault, and back, through the earth to the transformer. The magnitude of the earth current will depend on the electrical characteristics of the power line and the apparatus at both ends, and on the resistivity of the soil. The distribution of the earth current through the earth, will depend on the resistivity of the soil. As a rough approximation, this distributed current may be considered to have the same inductive effect on a parallel electric circuit, as a current equal in magnitude but concentrated in a path of small cross-section, at a certain depth, vertically below the power conductor. This is a somewhat similar consideration to the "image conductor" often adopted in electrostatic problems. The depth of the equivalent return path below the power conductor will vary with the resistivity of the earth, being greater at higher soil resistivities.

Certain investigators suggest that the depth of the equivalent return path below the power conductor might be given by an expression of the form

$$\frac{2.22}{\sqrt{4\pi\sigma\omega}} \text{ cm.}$$

where σ is the conductivity of the soil in C.G.S. units. This expression gives the depth of the equivalent return path as 1580 metres for a soil resistivity of 20,000 ohms per cm. cube and 766 metres for a soil resistivity of 4,700 ohms per cm. cube.

The "equivalent earth plane" will be the horizontal plane drawn midway between the conductor and its "image."

The magnetic induction between the power line and the parallel communications line, can be conceived as the magnetic induction between two parallel coils of wire both perpendicular to and symmetrical about the equivalent earth plane. The one coil, consisting of the faulty power circuit and its "image" carries a current and induces an e.m.f. in the other coil, which is composed of the communications line and its "image" with respect to the same equivalent earth plane.

It is a matter of elementary theory to show that the magnetic field surrounding two parallel wires such as the faulty phase wire and its "image" is represented by a system of co-axial circles.

Fig. 2 shows the magnetic field around a phase wire for assumed depth of the equivalent ground

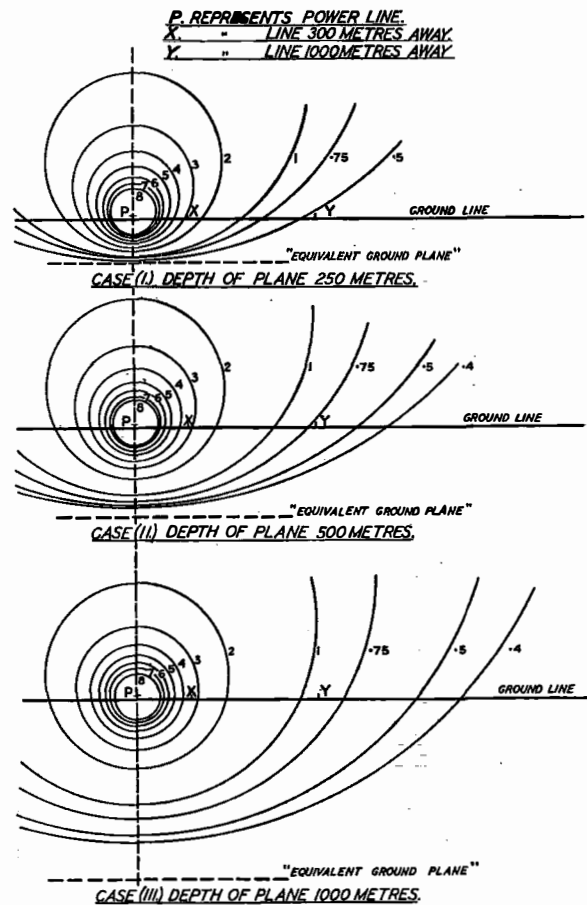

FIG. 2.—DISTRIBUTION OF MAGNETIC FIELD AROUND A SINGLE CONDUCTOR.

plane below the power wire of (a) 250 metres, (b) 500 metres and (c) 1000 metres. These three equivalent depths correspond roughly, according to

the formula $Depth = \frac{2.22}{\sqrt{4\pi\sigma\omega}}$ to average earth-

resistivities of 2,000, 8,000, and 33,200 ohms per cm. cube. The lines of force drawn have been chosen to represent the same value of total field strength at ground level in each case so that the diagrams illustrate two points :-

- (a) The magnetic field at any given conductor-position will increase with increase in the average earth resistivity.
- (b) An assumed higher value of earth resistivity will give a proportionately greater increase

in the magnetic field at a distant point than at a point near the power line. This is apparent if the field strengths at points X and Y are compared in the three cases.

The value of the mutual inductance is given by the integral of the magnetic field over the vertical plane between the conductor and its image, and thus the two points noted above are also found in the values of the inductance, but to different degrees.

The curves in Fig. 3 give Mutual Inductance in Henries $\times 10^{-4}$ per Km. of parallelism, calculated from the "equivalent earth-plane theory" for the three depths used above.

The height of the power line above earth has been chosen as 20 metres and that of the telephone line as 10 metres, but for all practical cases the difference

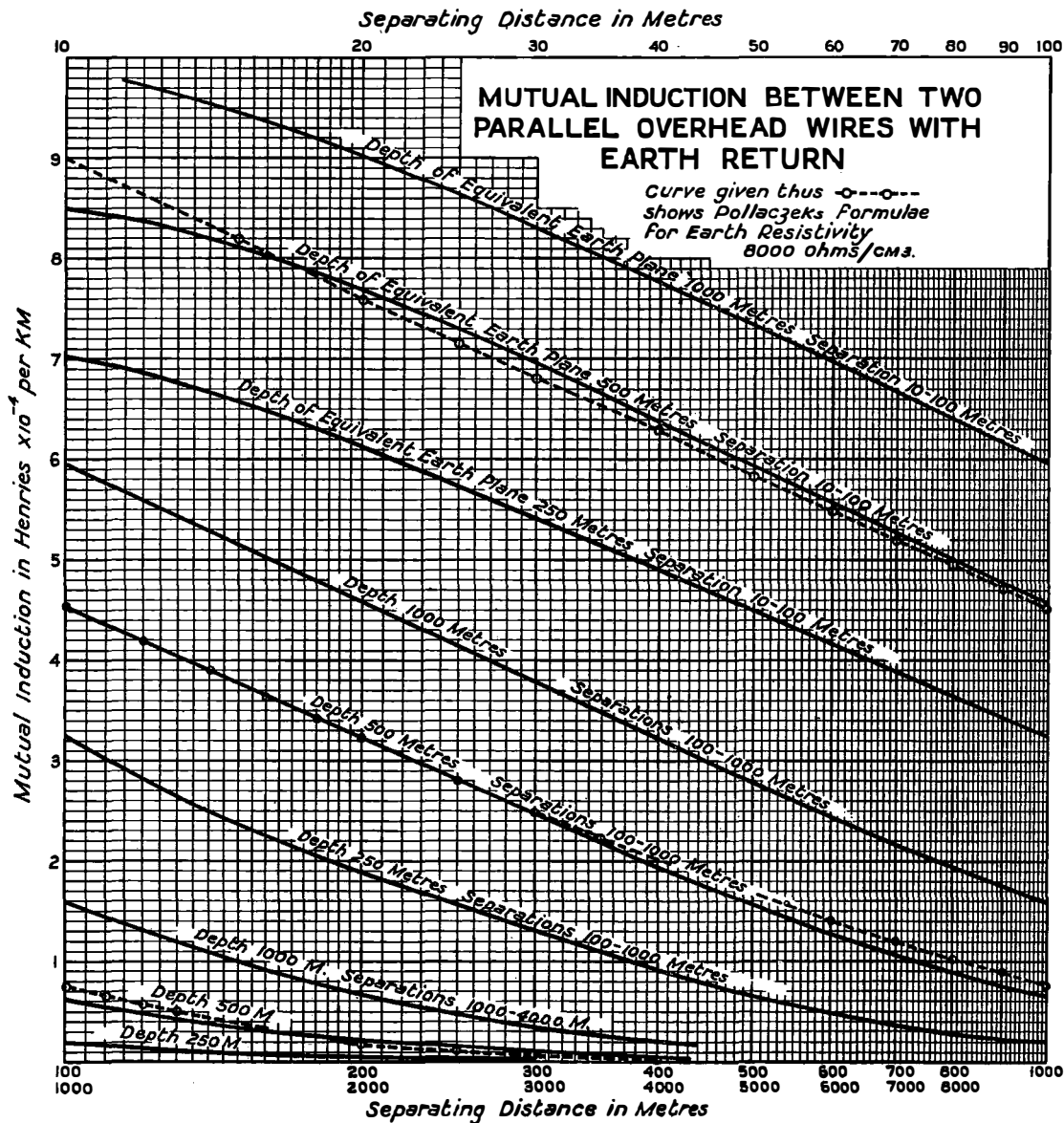

FIG. 3.

in height of these lines may be neglected and the formula reduces to

$$M = \log h \left[1 + \left(\frac{2D}{S} \right)^2 \right]$$

henries $\times 10^{-4}$ per Km.

where D = depth of ground plane below power line, in metres

and S = separation between the lines, in metres.

These curves show that a higher soil resistivity results in increased induction and also that an increase in the average resistivity assumed, results in a much greater proportionate increase in the induction on a line at a wide separation than on a line more closely paralleled.

A dotted line is given on the graphs in Fig. 3 to show the mutual inductance calculated from Pollaczek's formula for an assumed earth resistivity

of 8,000 ohms per cm. cube. It will be seen that whilst this curve has a different slope from the full-line curve for D = 500 metres the difference between the two curves is negligible for ordinary purposes. Hence it appears that if a depth of the equivalent earth plane could be arrived at in any particular case the simple theory would give calculated results of the same practical value as the results of the more complex formula.

The more exhaustive mathematical treatments consider the induction to be produced in two ways—

- (a) There is an aerial magnetic field set up around the power conductor. The effect of this is small at all but short distances.
- (b) The earth current sets up a magnetic field as well as a potential gradient due to the resistance of the earth path.

For use in any practical problem, fundamental curves based on the formula of Pollaczek have been obtained. These are reproduced in Fig. 4. They

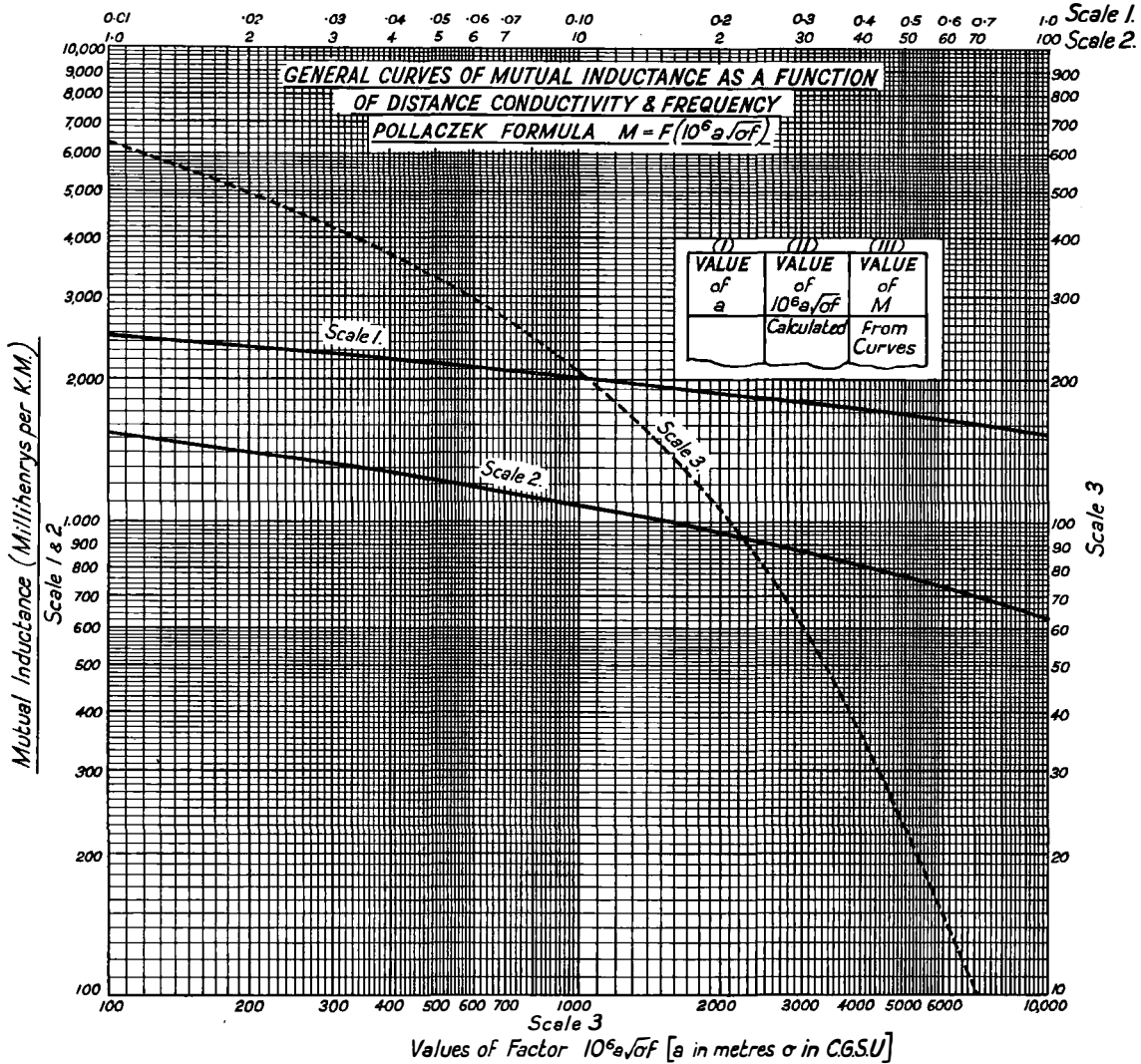

FIG. 4.

show mutual inductance in millihenries per Km. plotted on a basis of the factor $10^6 a \sqrt{\sigma \cdot f}$, where

- a = separating distance between power and telephone lines in metres
- σ = earth conductivity in C.G.S. units
- f = frequency of power supply—50 in all normal cases.

This expression contains the only variables likely to enter into practical problems, and when we have found values for two of the variables in any problem we can deduce from the fundamental curve a curve showing the variation of mutual inductance against the third variable.

Normally we require curves of M against a for an

assumed earth resistivity, or several earth resistivities. These curves are obtained by tabulating: (i) values of a , (ii) corresponding values of $10^6 a \sqrt{\sigma \cdot f}$, (iii) values of M read from the fundamental curves for values in (ii), and then finally plotting the values in column (iii) against those in column (i).

As stated above, in general cases, an assumed earth resistivity of 4,700 ohms per cm. cube is adopted. Curves for the mutual inductance against separating distance as normally used in the calculations are given in Fig. 5. The range of separations 10—10,000 metres covers all practical values.

The method of making calculations in a practical

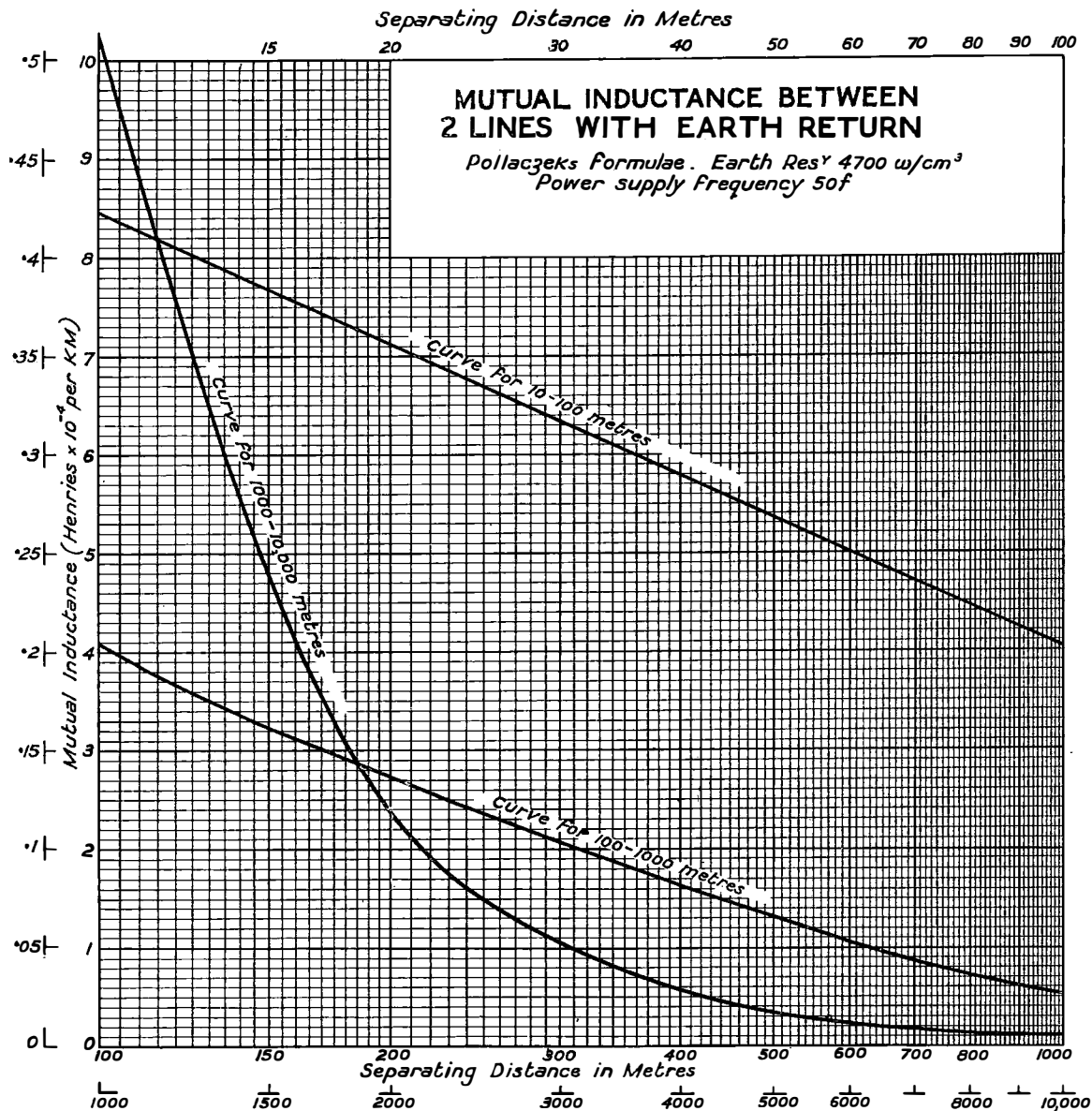

FIG. 5.

case of parallelism between an overhead power line AB and an overhead communication route CD, Fig. 6, is as follows :—

The power line is normally either straight or built in straight sections, whereas the communications route which is paralleled, follows a roadway and is by no means straight. The separating distance is therefore continually varying.

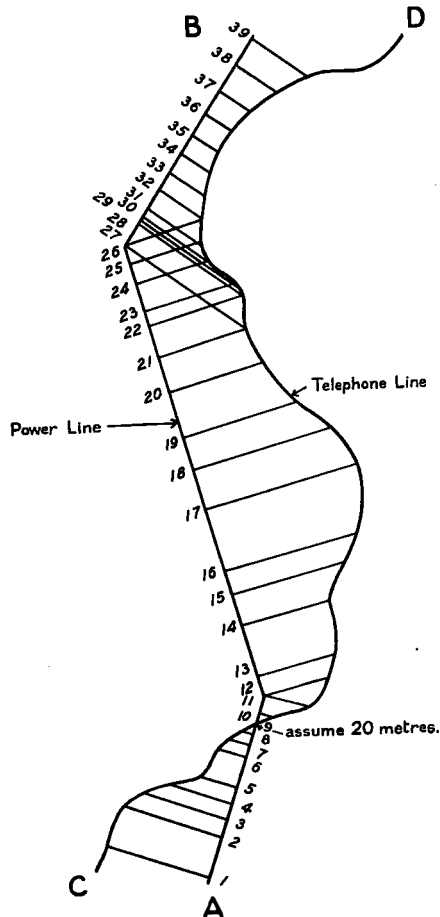

FIG. 6.—PARALLELISM BETWEEN POWER AND TELEPHONE LINES.

The two routes are plotted on 6" or 1" ordnance maps. Ordinates are drawn perpendicular to the plan of the power line with this line as base, and such that every pair of consecutive ordinates cuts off an intercept on the plan of the telephone line, which is reasonably straight. The ordinates will not be equally spaced and must be taken sufficiently closely together so that consecutive ordinates do not differ greatly in length. With this proviso it is considered sufficiently approximate to take the geometric mean of two adjacent ordinates as being the average separating distance over the section of the parallelism included between those ordinates. The separating distances are then entered and further calculations developed in the form illustrated below.

Separating Distance (Metres).			M	L	M.L.
Beginning of Section.	End of Section.	Mean (Geom.).			

The lengths of the ordinates in metres are tabulated in pairs in columns 1 and 2, the geometric mean of these values is entered in column 3, and the value of M (millihenries per Km.) read from the graph at the distance in column 3 is tabulated in column 4.

The length included between the ordinates, measured along the base line is tabulated in column 5 (in Km.) and the product of values in columns 4 and 5 is entered in column 6. These values are the mutual inductances for the various sections and their arithmetic sum is the total mutual inductance for the whole parallelism.

Assuming a value for the possible earth fault current and neglecting certain factors referred to later the calculation gives the voltage (E) which might be induced in the communication route from the formula $E = \omega(ML)I$.

It will be evident that the worst possible case has been considered, viz., a fault at one end of the power line fed from the power supply at the other end.

Overhead E.H.T. power lines are usually equipped with a ground-wire on the top of the towers, of comparable gauge to the power conductors and in metallic contact with the towers. The latter are connected to earth plates at frequent intervals,—normally at every fourth tower. Hence the ground-wire will carry back to the supply station a certain part of the earth fault current. The earth fault may consist of (a) a short-circuit between a phase-wire and a tower, or (b) a short-circuit between the phase-wire and the ground, but if the power line is of reasonable length the current in the earth wire at a distance of a few spans from the fault will not be very different for faults of either character. The current returning through the earth wire will have a neutralizing effect on the magnetic field set up by the fault current in the phase-wire, and will also reduce the value of the current in the earth (allowing for phase differences). It is usual to assume that the effect of this is to reduce the calculated mutual inductance by one-third. Hence the elementary formula becomes $E = \omega(ML)(\frac{2}{3}I)$ to allow for the effect of the earth wire.

So far overhead wires on both lines have been considered. Wires in an underground telephone cable may also be affected although they will be shielded by the lead sheath of the cable, and its armouring, if any. The same type of calculation will apply since the formula takes no account of the height of induced wire above the ground. Provisionally it has been assumed that the shielding effect of a lead sheath may be allowed for by multiplying the calculated inductance by 0.7. If the cable is armoured the factor is, at present, assumed to be

terminal apparatus. Further protection could be afforded by converting all overhead circuits into loop circuits, abandoning any single wire telegraphs, phantom circuits, or superposed telegraphs and to arrange for A.C. signalling instead of D.C. working. These loop circuits would be divided into separate physical lengths by the insertion of 1:1 screened transformers such that the induced voltage along each length would not exceed 300 v. Such a measure would introduce very difficult constructional and maintenance problems and as a general measure would be found impracticable.

An improvement in conditions can obviously be obtained by laying underground cables to replace the overhead routes. If the normal lead-covered cable is still endangered additional protection can be given by using armoured cable or laying cable in iron or steel pipe. It has also been suggested that copper tapes should be wrapped around the cable core under the lead sheath to increase the inductance

and reduce the resistance and thus further shield the conductors.

Before such protective measures are adopted it will, of course, be necessary to examine the case of suspected possible interference very closely either by experimental currents in the power line after its erection or by making an extensive series of earth-resistivity measurements and repeating the preliminary calculations on a basis of these values instead of on the assumed basis of 4,700 ohms per cm. cube.

This article does not attempt to add materially to the exhaustive theoretical studies referred to in the earlier paragraphs, but it explains briefly how the danger of inductive interference arises and how the problem is dealt with in the P.O. Engineering Department. It is hoped, therefore, that it will be found useful by those officers of the Department who wish to have a knowledge of the methods of treatment now in use.

Telegraph and Telephone Plant in the United Kingdom.

TELEPHONES AND WIRE MILEAGES. THE PROPERTY OF AND MAINTAINED BY THE POST OFFICE IN EACH ENGINEERING DISTRICT AS AT 31ST MARCH, 1933.

No. of Telephones owned and maintained by the Post Office.	Overhead Wire Mileages.				Engineering District.	Underground Wire Mileages.			
	Telegraph.	Trunk.	Exchange.	Spare.		Telegraph.	Trunk.	Exchange.	Spare.
793,806	599	8,838	42,143	3,035	London	42,539	189,768	3,522,340	155,515
94,990	1,962	19,289	44,125	5,175	S. Eastern	4,186	51,950	348,312	43,607
110,701	4,194	36,374	67,341	4,858	S. Western	24,114	33,949	278,472	67,259
75,309	4,689	40,261	64,662	8,551	Eastern	18,977	56,338	157,522	46,731
121,480	7,314	51,887	52,673	6,223	N. Midland	31,301	138,047	325,790	63,211
96,628	4,103	32,268	62,136	2,974	S. Midland	16,556	52,857	287,102	75,924
67,802	3,419	30,961	52,848	5,538	S. Wales	7,317	44,818	164,616	47,832
132,990	6,572	30,078	55,279	5,519	N. Wales	16,073	70,116	423,606	110,567
179,413	866	11,742	24,893	5,945	S. Lancs.	13,623	117,089	628,751	79,306
112,094	5,054	30,002	37,101	7,177	N. Eastern	19,630	77,121	323,720	44,961
74,269	4,141	22,698	26,084	5,189	N. Western	5,890	48,705	238,049	54,223
57,080	2,083	16,987	21,397	4,382	Northern	9,736	39,718	183,372	36,325
28,254	3,382	11,219	11,554	781	Ireland N.	526	4,265	65,401	6,288
81,514	4,723	32,490	39,012	2,631	Scotland E.	9,659	41,387	179,056	33,796
104,090	5,589	24,280	30,616	1,984	Scotland W	10,992	43,751	257,509	38,354
2,130,420	58,690	399,374	631,774	69,962	Totals.	231,119	1,009,879	7,383,618	903,899
2,114,126	58,928	403,527	625,782	65,898	Figures as at 31 Dec., 1932	231,688	954,155	7,317,598	916,087

Recent Developments in the Design of Loading Equipment for Junction Cables

A. O. GIBBON, M.I.E.E., and W. H. BRENT, B.Sc. (HONS.).

IMPORTANT developments are being introduced in connexion with junction cable loading equipment and it may be of interest to readers of *The Post Office Electrical Engineers' Journal* to examine the factors influencing these changes, also to discuss the uses to which the developments are being applied. The changes that are being made in loading coil design may be traced to a variety of causes; there has been considerable research work associated with the properties of materials used in the make-up of coils; much attention is being given to the need for higher standards of transmission in telephone networks; there have also been investigations made in simplification of manufacture, reductions in over-all dimensions of loading units, and a general review of the economics of the subject from an installation engineer's point of view.

Research work on loading has been responsible for the production of alloys of greatly improved permeability at low flux densities. Probably the most outstanding advance in this direction in recent years has been concerned with the loading of trans-oceanic telegraph cables. The loading of these submarine telegraph cables was effected by the use of Permalloy wire applied continuously round the cable conductors and this method of loading resulted in a remarkable increase in the speed of working of telegraph circuits associated with such cables. It was a natural development that Permalloy and similar materials should be considered for use in connexion with the coil loading of telephone cables. Experiments have also been made in the use of chopped wire, iron dust, or of specially prepared powdered alloys, in the construction of suitable cores for loading coils. These preparations are formed into suitable cores under pressures of the order of 50 tons to the square inch and, as a result of the separation of the particles composing the core, have considerably decreased hysteresis losses, which normally show up in the form of increased coil resistance to the passage of alternating currents of speech frequencies. In addition to the advantages gained from the reductions in size and weight of the core made up from one or other of the alloys or materials referred to above, there is less likelihood of permanent magnetization taking place in the core.

Turning to the transmission aspects of loading of telephone cables, the general policy adopted by the British Post Office is to provide circuits in underground cables for minor trunk, and important junction purposes made up of light gauge conductors. Arrangements are made for these cables to be coil loaded and for amplifiers to be applied at

definite intervals for two- or four-wire working.¹ These circuits are required mainly for service between large centres, and the constructional arrangements have followed one or other of the following methods:—

- (a) The drawing-in of lead covered cables into conduits and the provision in manholes of loading units of the ordinary cast-iron type.
- (b) Armoured cable laid direct in the ground and the provision of buried types of loading coil pots.²
- (c) Aerial cables in conjunction with a pole mounted type of loading coil unit.³

The types of circuit referred to above replace the 40 lb. or 70 lb. loaded cable conductors employed hitherto.

In London, and also in large provincial centres, there are numbers of short Trunk, Toll and Junction circuits carried in 20 lb. or 40 lb. conductor cables. These cables have not been loaded up to the present time, as they have been used for lower grade circuits. The introduction of Voice Frequency Key-sending in London has called for a large amount of re-routing of circuits *via* these cables, and the up-grading of the circuits has become necessary. The provision of loading coils in such cases greatly depends upon whether the coils can be supplied and fitted economically, having regard to the fact that in the majority of cases the cables concerned are in position in congested manholes.

Schemes for the loading of the undermentioned cables have been authorized initially, viz.: Tandem—Lee Green, Tandem—Livingstone, Tandem—Edgware, Kensington—Waxlow—Hounslow, etc., and arrangements have been made to introduce coils of special type for the purpose. As a result of the specialised application of loading to the cables referred to, it has been found possible to modify the standard electrical requirements of loading units in order to suit particular cases, and there are now three Post Office specifications⁴ in operation which cater for Main Trunk, Minor Trunk, and Junction or Toll circuit loading. These are referred to as A, B and C type coils respectively, and Table I has been extracted from the specifications in order to show the effect upon a particular value of coil (120 Millihenries). The differences are chiefly noticeable in the resistances of the coils to direct current, and also to alternating current of speech frequencies; a lower ratio of inductance to resistance is allowed in the case of the B and C type coils compared with the previously existing A type of coil. The same standards of capacity balance and inductance variations, which

affect interference or cross-talk between circuits, are however maintained for the A and B types, but for the C type, wider inductance limits are permitted between the two line windings of a coil.

TABLE I.
COMPARISON OF ELECTRICAL CHARACTERISTICS.

Coil.	Standard Inductance.	D.C. Resistance at 60°F.	Effective A.C. Resistance.	
			800 p.p.s.	1800 p.p.s.
	Milli-henries.	Maximum ohms.	Maximum ohms.	Maximum ohms.
Type A	120	5.7	7.0	9.5
Type B	120	7.8	9.0	12.2
Type C	120	10.2	11.8	14.6

[Since writing the article, new specifications have been introduced, re-grading the types of coils shown in Table I. Under the new arrangement, there will be a coil of better electrical characteristics than the A type, viz., Grade 1 for Major Trunk circuits; Junction circuits will be loaded with Grade 3 or 4 loading coils, the latter corresponding fairly closely to the C type referred to in this article. See also B.P.O. Specifications 522, 523, and 524.]

It is of interest, at this stage, to examine the effects of the modifications referred to in Table I upon the volumes of the coils and some comparative figures for B and C type coils expressed as percentages of the volume taken up by the particular A-type coil of the firm referred to are given in Table II, the same type of core being assumed in each case. The weight naturally follows volume, but some data as regards weight will be given later, when consideration is given to the assembly of coils in the pot as a complete unit.

TABLE II.
COMPARISON OF COIL SPACE.

Coil.	Standard Telephone & Cables, Ltd.	Salford Electrical Instruments, Ltd. (G.E.C.)	Siemens Bros.	Automatic Electric Co.
Type A	100%	100%	100%	100%
Type B	30%	33%	22%	76%
Type C	17%	20%	18%	42%

Actually the dimensions of a C type coil are of the order of two inches in diameter and slightly less than one inch in height, the values varying with the different manufacturers.

The effect of these considerations upon buried type loading coil pots for use in association with

armoured cables has already been described in this Journal² and, in the article referred to, attention was chiefly directed to the accommodation of the cable joints, without resorting to the building of manholes, also to the relations of cable jointing space to loading coil space. The conditions usually met with in the case of junction loading are somewhat different, inasmuch as manhole accommodation, although often congested, is generally available. The provision of manhole space leaves the engineer free to deal with the cable joints as a matter more or less separate from that of the best accommodation of the coil case. The cable joints to and from the coils must be accessible, whilst the loading units may be placed in unobtrusive positions. In this way the most efficient use can be made of the space available in a manhole; frequently in a chamber which was not intended to house loading coils. The manufacturers concerned in the supply of loading pots, in co-operation with Post Office engineers, have tackled the problem of housing units for junction loading in existing manholes in a variety of ways. It is proposed to give a brief description of the different methods adopted and to comment upon the arrangements made by the manufacturers in dealing with a new technique in underground cable work.

It will be obvious that the C type coils could be accommodated in a cast iron pot in precisely the same manner as is done in standard trunk loading practice. This method is well known and need not be enlarged upon in this article. The only difference would be that if cast iron were used to house the pots, a case of smaller dimensions would be employed. Investigations have been made with the object of breaking away from the cast iron case design and to search for other and more convenient forms. The first and most important step was made by abandoning the use of cast iron as the protecting cover. Such a casting as this has to be manufactured $\frac{3}{8}$ inch to $\frac{1}{2}$ inch thick to ensure that a good material is obtained, free from blowholes and other sources of weakness, and strong enough to stand a minimum internal pressure of 20 lbs. per sq. in., before issue. A casting of this order is unduly heavy. Further, the proper securing of the lid of the C.I. case necessitates the provision of a large flange joint between case and cover which adds to the overall dimensions and mitigates against the efficient utilisation of manhole space.

One disadvantage of the cast iron type of loading coil pot is the difficulty encountered in obtaining complete immunity from moisture. When the molten iron passes into the mould through the narrow space around the large sand core, slag tends to gather, or bubbles of vapour to become trapped, leaving minute paths for the ingress of water when the casting cools. It is therefore necessary to thoroughly test each cast iron pot under air or water pressure in order to detect and repair any leaks, and this process presents some difficulty. Nevertheless

some defects remain and these are filled in with Dr. Angus Smith's compound, which is applied to the whole of the external surface to render it less liable to corrosion.

Another weakness is the joint between the body of the case and the cover, since it is almost impossible to secure a joint that will be thoroughly watertight under extreme variations of temperature and atmospheric pressure. A bolted flanged joint with machined surfaces and a copper gasket, coated with red lead, is usually fitted, but as this may not remain moisture-tight for any period of time, the real seal at this point is secured by means of a tongue and groove filled with a packing material, such as Asphaltum. Further sources of weakness are the nipples, to which the stub cables are wiped. These nipples are merely threaded into the cover plate and are liable to develop leaks, especially after the stub has been wiped to the nipples.

Welded sheet steel casing offers a direct answer to these disadvantages, in that such a material can be used with a thickness of not more than $\frac{1}{4}$ inch, affording ample strength and reliability; the steel welding also avoids the need for a heavy flange joint. Moreover, the sheet form of construction is more amenable to the work and it can be fashioned to conform closely to the shape of the assembled coils which are to be enclosed. As would be expected, therefore, welded steel cases have been designed by all the loading coil manufacturers and at present actual pots of this type are being supplied by the different companies for the loading of junction cables. A pot of this type, manufactured by the Automatic Electric (late A.T.M.) Co. is shown in Fig. 1. The shape is a compact one, considering that the case contains 256 coils. A detailed photograph of the top of the pot is given in Fig. 2.

Typical dimensions of welded steel pots are given in the following table:—

TABLE III.
TYPICAL DIMENSIONS OF WELDED STEEL
LOADING COIL CASES.

Manufacturer.	Coils (Maximum).	Breadth.	Depth.	Overall Height to Bracket.
		<i>inches.</i>	<i>inches.</i>	<i>inches.</i>
Salford Electrical Instruments, Ltd. (G.E.C.)	256	10 $\frac{3}{4}$	10 $\frac{3}{4}$	26 $\frac{3}{4}$
Standard Telephones & Cables, Ltd.	254 150	20 $\frac{1}{2}$ 9 $\frac{5}{8}$ (Circular Section)	11 9 $\frac{5}{8}$	31 $\frac{1}{2}$ 36 $\frac{1}{4}$
Siemens Bros.	256 128	11 10 $\frac{1}{2}$	11 10 $\frac{1}{2}$	32 22
Automatic Electric Company.	256	11	11	33

Messrs. Standard Telephones and Cables, Ltd., have also put forward a welded steel cased unit con-

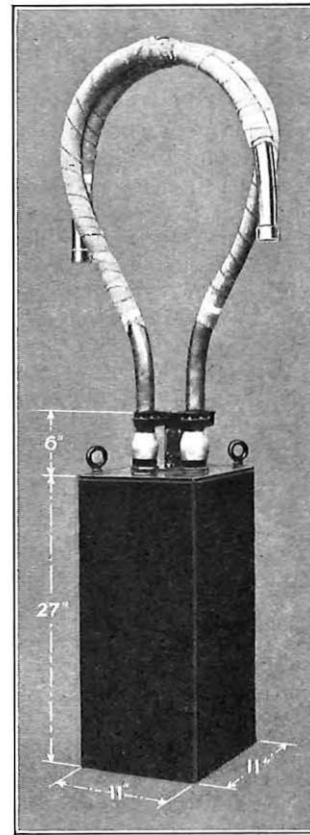

FIG. 1.—WELDED STEEL LOADING POT (AUTOMATIC ELECTRIC CO'S DESIGN).

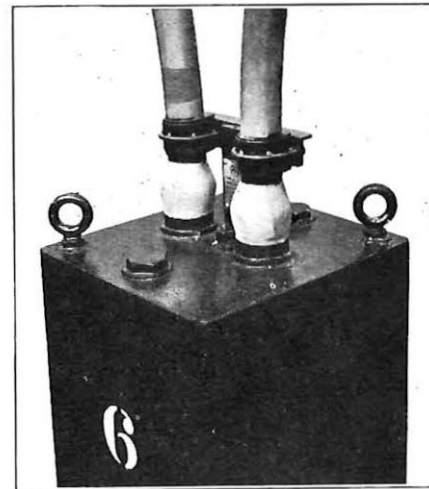

FIG. 2.—DETAIL OF TOP OF LOADING POT (AUTOMATIC ELECTRIC CO'S DESIGN).

taining 100 coils, the depth of the case being only 4 $\frac{1}{2}$ inches, the other dimensions being 1 ft. 2 inches in breadth and 2 ft. 10 ins. in height. In this proposal, a number of these units colloquially referred

to as "suit cases," were intended to be placed around the walls of a manhole for loading a cable on a "Unit" principle.

The square or rectangular section of case is a convenient shape and allows the unit to stand against the wall of the manhole, avoiding interference to the gangway. In the case of one manhole surveyed for this type of loading, the manhole measured 4 ft. wide, 7 ft. long, and 6 ft. 6 ins. high; the cables from 12 duct ways were jointed across one half of the available space of the manhole, leaving a clearance of approximately 18 inches in which to place a coil case. With the dimensions of the loading case offered by the manufacturers, the placing of the unit in the manhole did not present a difficulty, but another problem arose, namely, that of jointing the junction cable to the coils. It was calculated that the lengths of stub cable required to connect the cable to be loaded, with the pot in the chosen position, would be 8 ft. and 17 ft. respectively. The 8 ft. length can be provided, but the provision of a 17 ft. stub cable is impracticable, especially in view of the fact that a 254 pair cable is concerned. In such eventualities there is no alternative but to have a standard length of stub (six feet) and to joint in an extra cable length to connect to the main cable. On account of the lack of choice in the positioning of the pot, it is apparent that it will be an advantage if, in making the preliminary survey of the manholes, some note is made of any cases where an extra

2 or 3 ft. (or more if the stub cable is of small diameter) on the standard length, will save an additional joint. An alternative arrangement, which has not yet been fully investigated, is the designing of a loading pot of wide and flat dimensions, say, not more than 1 foot in height, which may be suitable to insert on the floor of the manhole underneath the run of the main cables.

As will have been gathered, the use of welded steel will lead to considerable reductions in weight of the complete assembly of container and coils. The reduction is striking. As an example, the first coil case whose dimensions are given in Table III, namely, the 256 coil pot of the Salford Electrical Instruments, Limited (G.E.C.), weighs 240 lbs., or just over 2 cwt. A standard design of cast iron case, containing the same 256 coils, and made by the same firm, weighs 560 lbs. or more than twice as much as the welded steel type. Fig. 3 illustrates cast iron and welded steel designs of loading pots of equal capacity, which have been manufactured by the G.E.C.

In choosing new materials for the construction of the coil cases, an essential requirement is that corrosion effects must be kept to a minimum. Consideration has been given to the use of stainless steel, such as, for example, chromium steel of 18% chromium and 8% nickel, which would reduce corrosion to a negligible amount. This material is expensive, being considerably more costly than mild

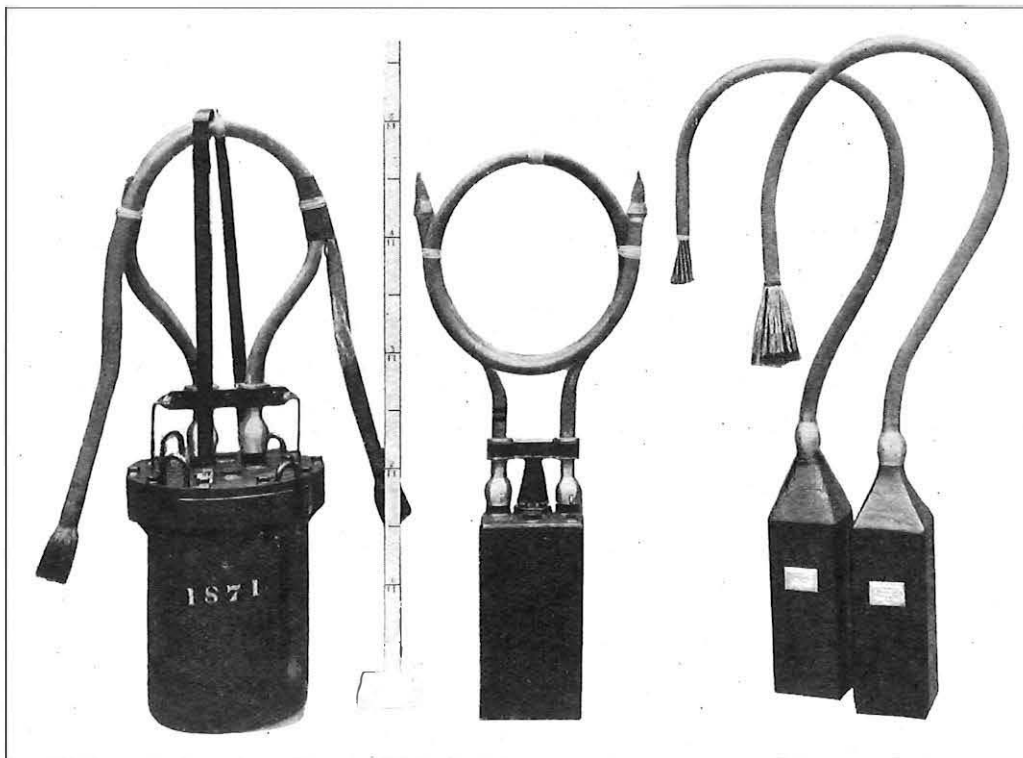

FIG. 3.—ILLUSTRATION OF DIFFERENT LOADING UNITS FOR C TYPE COILS (SALFORD ELECTRICAL INSTRUMENTS, LTD., G.E.C.).

steel. The application of an efficient protective coating to the welded steel case is a more economical proposition. Thus, the present type of welded steel pot is being supplied heavily tinned over the whole surface and finished with two coats of bitumastic paint. Also a suitable footstool iron bearer 3 inches in height is being provided with the pots, to raise them out of the layer of mud which may sometimes accumulate on the manhole floor.

The standard procedure is followed for drying the completed case under vacuum, with the filling plug removed and the ends of the stub cable left open. Finally, the interior is filled up with a moisture resisting compound and, after the filling cap has been screwed down and soldered in place, the whole case is given two coats of bitumastic paint.

One of the first designs considered for conveniently accommodating the coils was based on the idea of an "enlarged joint." Where a few circuits, such as music circuits provided for the British Broadcasting Corporation have to be loaded at certain points the coils have sometimes been inserted, together with the usual cable wire joints, in a slightly larger lead jointing sleeve.

It was in order to investigate fully this departure from standard design that Messrs. Standard Telephones and Cables, Ltd., offered a "Torpedo" type of case to take the place of one of the floor type of pots to be supplied on the Kensington-Edgware cable. As 225 junction circuits were to be loaded with C type coils at each point, it will be realised that to accomplish this successfully, certain difficulties had to be overcome. Fig. 4 is a photograph



FIG. 4.—STANDARD TELEPHONES AND CABLES CO'S "TORPEDO" TYPE OF LOADING COIL UNIT.

of the unit as issued from the company's factory; it will be seen that the case consists of a lead cylinder with end pieces, which are conically shaped for strengthening purposes and out of which the connecting leads are brought. The cylinder contains the coils, which are mounted in 8 columns about one centre column, and the coils are held rigidly together by a "spider" at each end. The diameter of the cylinder itself is $9\frac{1}{2}$ " and the length of the unit is 3 feet 6 inches overall. As regards weight the torpedo design is approximately 200 lbs., compared with 800 lbs. for a C.I. case design offered under the same contract, or 1160 lbs. for a C.I. case containing B type loading coils. A novel feature of the torpedo design is the method adopted for jointing the coils

in circuit with the cable. The coil leads are brought out at each end by means of textile covered wires, specially impregnated, to render them capable of maintaining their insulation throughout the time required for jointing. The leads are seen enclosed in rubber tube sheathing for transport from the factory, and the installation is carried out by first threading the wires through lead tubes previously bent at the factory to the configuration required. The lead tube is solder-wiped to its conical end and a sleeve joint made between the tube and the cable, when jointing is complete. In the most convenient arrangement, one cable joint may be located above the pot and one below, or, as in the case of the unit installed in the Maida Vale manhole, both joints may be placed underneath, as illustrated in Fig. 5,

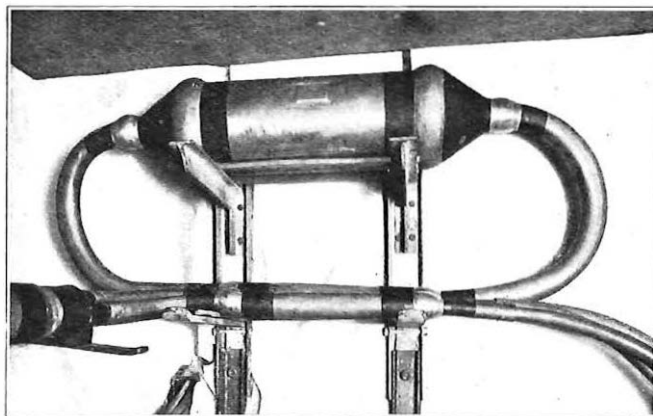

FIG. 5.—"TORPEDO" TYPE OF LOADING COIL UNIT IN MAIDA VALE EXCHANGE MANHOLE.

which shows the torpedo unit fitted on special bearers and the tubes bent round for the two joints to be carried on the lower brackets of the bearer. One advantage of this type of construction is that ease of transport is afforded, because the rubber-cased leads are fixed close to the body of the pot; this arrangement also allows the units to be lowered through any manhole cover or shaft not originally built for the accommodation of loading coil pots. The use of the torpedo type of case demands that a special survey be made of the manholes to determine within narrow limits where the pot, each of its joints, and the special bearer are to be placed.

The G.E.C. were also pioneers in this torpedo design of pot and this was developed from their special unitary system of manufacture. A description of the internal construction of such a pot is given below. The coils are in separate long steel tubes of square section, the side of which is slightly greater than the diameter of a single coil, and the leads to the coils are taken down the corners of the square. Each steel tube is filled with compound after the coils have been put in, and each tube of coils is replaceable without disturbing the coils in the other tubes. The original design had 18 coils

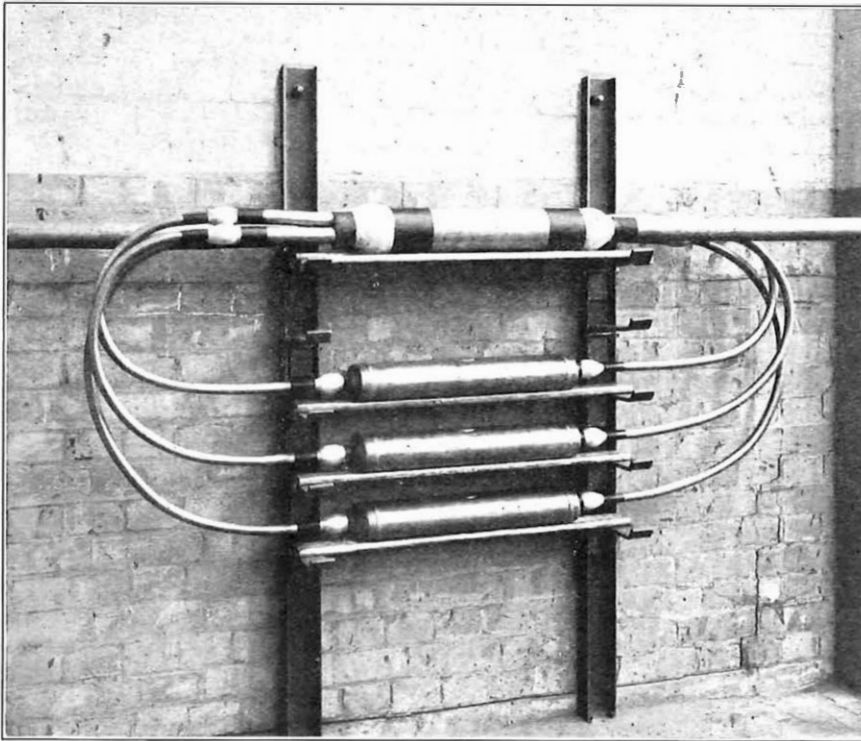

FIG. 6.—SIEMENS BROTHERS' UNIT SYSTEM OF LOADING.

encased in a square section sheet iron tube fitted with an ebonite plate at each end, and the quadded connecting wires were taken through holes in the plates. Such units can be enclosed in an enlarged cable joint. A modified design, based on this principle, had 20 coils enclosed in a square section iron tube covered with lead, and was fitted with stubs at each end. A third development had four of these units, each holding 32 coils in a brass container, stacked into a square tube covered by a thick lead sheet and fitted with stubs.

Messrs. Siemens Bros. proposed a "Unit" system of loading, preferring to secure ease of handling and support of the coil container, at the expense of a slight complication of the cable jointing arrangements. As a maximum size of unit, one containing 60 coils is in mind under this scheme, and the type is a lead cased one having the 60 coils arranged in horizontal columns of 15 coils each, to give a square section with sides $5\frac{1}{4}$ inches overall. A unit would be provided with a stub cable at each end for the in and out wires respectively, and the full loading of a cable would be obtained by connecting to the main cable, by means of multiple plug joints, as many units as are required. This idea is well illustrated in Fig. 6 which is a photograph taken

of three 30-coil units as they would be mounted on the cable brackets. Those shown in the figure are actually some of the units supplied for the initial loading of 30 pairs of the Dudley-Wolverhampton 104 pr/40 lb. cable, the stubs in the case of this cable being led into a single joint of the subsidiary cable type, with the unloaded pairs taken straight through. It will be appreciated that this method of building up with units offers a convenience for economically deferring part of the loading until the incidence of traffic necessitates the provision of more loaded pairs.

As regards weight, the Dudley-Wolverhampton 30-coil units weigh only 36 lbs., the dimensions being $2\frac{3}{4}$ inches high, $5\frac{1}{4}$ inches broad and 19 inches long, the units are easily accommodated on the standard cable bearers

and thus no abnormal provision of bearers is required, beyond that of obtaining one iron cross-support with a lead sheet cover to go between the brackets for each unit.

Details of the Siemens type of double-ended loading case are shown in Fig. 7. The welding of the lead sheet, also the internal strengthening arrangements of the case are clearly seen in the figure.

If manholes have to be built, as was the case with the Dudley-Wolverhampton cable, there being no existing manholes at or within a permissible distance of the loading points, the regulation size of loading manhole is not required to house these small units,

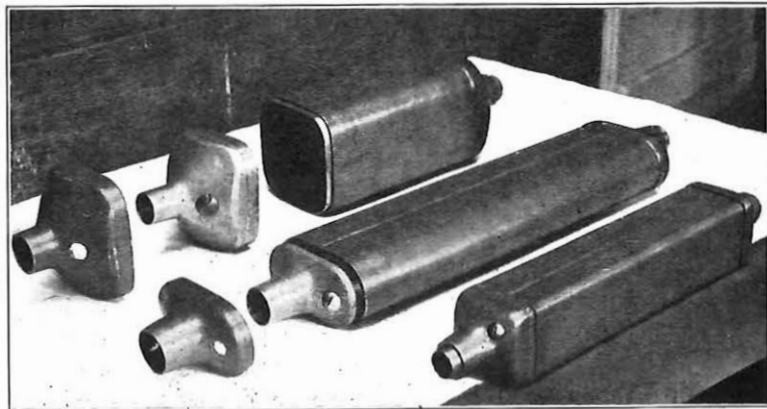

FIG. 7.—DETAILS OF SIEMENS TYPE OF LEAD-COVERED LOADING UNITS.

and the dimensions of an R.C.F. 2 type manhole, namely, 4 ft. 3½ inches long by 3 ft. 6 inches wide by 5 ft. high are quite suitable, if there are only a few local cables running through the same duct route, thus reducing building costs to a minimum. The overall length of wall space occupied by the units described in the photograph is just over 4 ft., the vertical height being approximately 2 ft. 6 inches. The arrangement can moreover be varied; for example, one or all of the units might be placed above the cable joints or, if necessary, two units placed on one bracket side by side. This design of double-ended lead cased coil container, has also been authorised for the loading of 6 pairs in the St. Albans-Welwyn cable.

Another "Unit" system has been suggested by the G.E.C. incorporating a different design of coil case. The maximum capacity of a unit in this scheme is 128 coils and these would be housed in a vertical case with a single stub carrying the in- and out-quads, rising out of the top from a pyramidal termination. Fig. 3 shows two of these "units" with a combined capacity of 250 C type coils, together with a welded steel pot (centre) and a standard cast iron manhole type pot (left), each of 250 C type coil capacity. The internal construction is the special unitary one described earlier. The original design had four of the square tubes, each holding 32 coils, held in a brass container, with a thick lead sheet covering all. One experimental design had no stub cable, but was provided with a pyramidal joint cover which could be slipped over the cable and replaced over the wire joints and sealed by solder wipes. As this association of the joints with the loading pot necessarily departs from the principle of having the cable joints in a part of the manhole which is most accessible, and the pots in another out-of-the-way position, a design was prepared having these joints made in the factory and provided with a stub cable. Also, to reduce the overall height, nine steel tubes each containing a smaller number of coils, were substituted for the four tubes, producing the units shown in Fig. 3. These units are 7¼ inches square and 2 ft. 2 inches in height.

Fig. 8 shows the way in which two 125 coil units would be used for loading a 250-pair junction cable; a typical city manhole, 7 ft. long by 4 ft. wide, already containing two standard pots, being assumed. It will be seen that the units fit in to the corners of the manhole and the single stubs, of the same size as the main cable as they carry both in- and out-wires, are in this scheme brought up to a multiple joint. This system involves the construction of a multiple plug joint, but by equally dividing the loading between two units in this way, a uniform joint is obtained with the in-wires of one unit doubled back in one half of the sleeve and the out-wires of the other unit doubled back to the single stub in the other half, the remaining joints being made straight through the sleeve. Any unloaded pairs can of

course be taken straight across and the method lends itself readily to the partial loading of a cable. The units are portable and can be lowered by means of a rope sling without tackle, a 128 coil unit weighing only 130 lbs. The units can be installed in any position, vertically in a corner, or horizontally on a wall at right angles to the lay of the cables. Further, in the event of a fault, replacement of a unit can be made without disturbing half of the circuits in the cable, a remark which applies equally to the Siemens unit system. Also, if a definite series of units from 128 coils downwards were held in stock by the Stores Department, no time would be lost in carrying out such a replacement. At the present time 104 coil units of this type are being installed on the New Cross-Hither Green junction route.

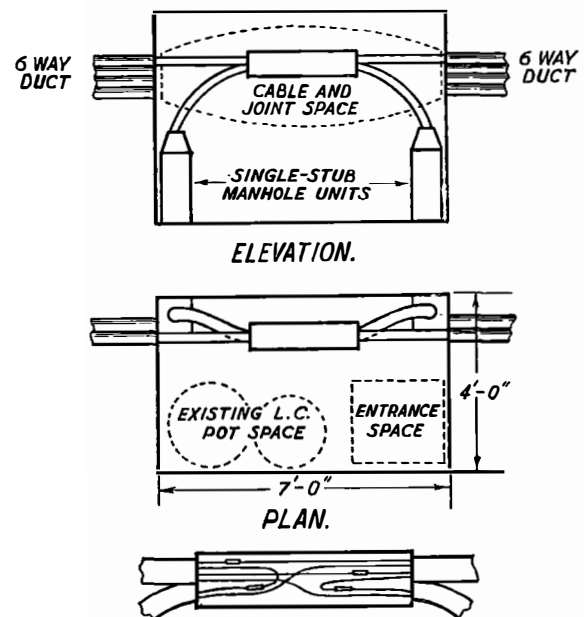

FIG. 8.—SALFORD ELECTRICAL INSTRUMENTS (G.E.C.) UNIT SYSTEM OF LOADING.

In addition to the designs of case described above, investigation is being continued in other directions, and interesting developments may take place, although care has to be exercised not to allow too great a diversity of detail to be applied. For example, the buried type of pot, with its absence of stub cables may, with certain modifications, be found adaptable for manhole work under the congested conditions described in this review. The object of this article is to give a general impression of the way in which the requirements of junction cable loading are being dealt with. The departure from "cast iron" methods of case construction has effected substantial reductions in weights of loading units; this has in turn facilitated transport and made handling on site more convenient. One of the most important results of the new loading design is con-

cerned with the housing of a large number of coils in existing congested manholes in the London area, where, under loading practice current only two or three years ago, extensive rebuilding and considerable additional expense would have been involved.

¹ I.P.O.E.E. Paper on "A Trunk Telephone Re-organisation Plan." J. S. Elston. October, 1931.

² J.I.P.O.E.E. "Buried Loading Coil Pots." W. H. Brent. July, 1932.

³ J.I.P.O.E.E. "Trunk Line Aerial Cable Construction." G. W. Craddock and W. H. Brent. October, 1931.

⁴ B.P.O. Specifications 471, 500 and 508. Now replaced by Specifications 522, 523 and 524 (May, 1933).

The New Agreements for Wayleave and Maintenance of P.O. Plant on Railways

IN the near future new agreements with the four Group Railway Companies will come into force which will supersede, with one or two exceptions, all existing agreements and arrangements which have hitherto governed the construction and maintenance of telegraph and telephone plant on the different sections of the Companies' undertakings.

Every Superintending or Sectional Engineer will doubtless be familiar with the difficulties encountered in the past in deciding the precise wayleave and maintenance rights of the Post Office on the particular piece of railway property on which it was desired to place new plant, the particular form which should be used in acquainting the Company concerned of his proposal, and whether or not payment should be offered. Similar difficulties, too, were experienced by the Companies in dealing with the matter from their side.

With the amalgamation of the original Companies into Group Companies under the Railways Act, 1921, and consequent concentration of the working of the systems and gradual dispersal of the local staffs of the old Companies, these difficulties were accentuated and it soon became evident that a radical change of practice was necessary to prevent delay to Post Office works. Such a change could not, however, be brought about until the matter had been carefully examined from every aspect, not only by the Post Office, but also by the Companies.

As an initial step the Telegraph Superintendents of the Group Companies were sounded informally on the subject of introducing uniform arrangements throughout each Group system and were found to be strongly in favour of this. The exact form which the formal proposals to the Companies should take was then considered by a Departmental Committee, representing the Secretary, the Comptroller and Accountant General, and the Engineer-in-Chief, which reached the conclusion that uniformity of procedure could be secured only by making the

Postmaster-General's rights of wayleave, construction, and maintenance uniform throughout each Railway system and by abolishing individual payments for items, and that this would involve the cancellation of existing agreements and the substitution of a new comprehensive agreement with each Company, which would provide, *inter alia*, for an inclusive annual payment covering all facilities for wayleave, waiver of maintenance, etc., for which the Companies were entitled to claim payment under the existing agreements. To make a proposal on these lines sufficiently attractive to the Companies, the Committee considered that the Post Office should offer to surrender its exclusive rights of wayleave and its rights of free conveyance, and to make certain concessions in the matter of the incidence of cost of alterations; it should also agree to a restriction of its rights of construction and maintenance on "Interregnum" and post 1878 railways. In return, it was to be expected that the Companies would be prepared to give the Post Office a general right of construction and maintenance for lines of greater length, perhaps up to a mile, in place of the right up to a quarter of a mile conferred by the Telegraph (Construction) Act, 1911.

It was proposed to make the annual inclusive payment revisable at intervals of five years, the basis of revision to be the actual mileage of Post Office wire on the Company's entire system. The payment was not, however, to cover maintenance performed by the Companies, which was to continue to be paid for on the basis of the actual mileage of wire and apparatus maintained, the rates of payment to be revisable at the same intervals as the inclusive "wayleave" payment.

The Heads of Agreement prepared by the Committee were approved by the Department and were accepted by the Railway Companies as a suitable basis of discussion with a Committee which they appointed for the purpose. Various meetings were

held with this Committee and, as a result, the form of a model draft agreement covering the whole field of the Department's relations with the Companies in the matter of telegraphic lines was eventually settled and all rates of payment agreed which were common to the four Companies, including percentage additions to their labour charges in accounts against the Department. The settlement thus reached, which was approved both by the General Managers of the Companies and by the Post Office, differed somewhat from the original Post Office proposals, but chiefly in the form of enlarging the scope of the arrangement. In particular, at the suggestion of the Companies, the annual inclusive wayleave payment was to be fixed once and for all and would be subject to revision only in the event of the value of the Post Office rights being materially lessened by action on the part of a Company.

Apart from the conclusion of the necessary formal agreements, the only matter left unsettled was the negotiation with the individual Companies of the inclusive annual payments which were to replace the various existing payments for wayleave, waiver of maintenance, etc., and this was also successfully carried out by means of personal discussion with representatives of the Companies.

The chief provisions of the new agreements may be summarized as follows :—

- (1) Subject to the exceptions mentioned below in (8) the Post Office obtains a perpetual right of wayleave over the whole of the railways, canals, docks, harbours, and piers for the time being owned, leased or worked by a Company, whether solely or jointly, and all lands and buildings owned by the Company. The wayleave is not exclusive and is subject to special restrictions in the case of isolated property or property not in the Company's own occupation.
- (2) The Post Office has a right to construct and maintain telegraphic lines up to a quarter of a mile in length. The Companies have the right to construct and maintain lines exceeding that length, but they have agreed to allow the Post Office to continue to maintain lines beyond that length which are now in Post Office maintenance unless such lines contain wires provided for a Company's own service, in which case the Companies have the right to take over maintenance.
- (3) A common form of application will be used for all proposals for the construction by the Post Office of new plant.
- (4) Both the Companies and the Post Office will allow their posts to be used for the other's wires, but the maintenance of such wires will normally be undertaken by the party which maintains the posts.

- (5) All individual payments for wayleave, waiver of maintenance, use of posts, etc., will cease and will, as from the 1st October, 1932, be merged in inclusive annual payments of
 - £13,700 to the London Midland & Scottish Company.
 - £6,500 to the Great Western Company.
 - £1,600 to the Southern Company.
 - £4,250 to the London & North Eastern Company.
- (6) The Post Office will bear the cost of all alterations necessitated by a Company's works to plant in Post Office maintenance on Railway property, unless wires maintained for Railway use are involved in which case the Company concerned will bear an appropriate proportion of the cost. In the case of Post Office wires in Railway maintenance, the cost will be borne by the Company if the works necessitating the alteration are carried out under Special Parliamentary powers, and by the Post Office if the alterations are carried out under the Company's general powers; but if in the latter case the posts carrying the Post Office wires also carry Railway wires, the cost is apportioned.

If Post Office lines on highways crossing or crossed by a railway at bridges or level crossings require to be altered in consequence of a Company's works, the Post Office will bear the cost if the Company are exercising their general powers and the Company if they are exercising special Parliamentary powers.
- (7) The rate of payment to the Companies for maintenance of Post Office wires, at present 33/- a mile of wire a year, is to be revised at the end of every five years from the 30th September, 1929. The standard flagging charge is similarly revisable.
- (8) The Post Office surrenders all rights to free conveyance.
- (9) The agreements will not apply to the provision of Exchange Telephone services for the Companies, to railway property in Ireland, nor to the three following undertakings :—
 - Severn Tunnel—Great Western Company.
 - Southampton Docks—Southern Company.
 - Forth Bridge—London & North Eastern Company.

It only remains to add that the agreements were negotiated in a spirit of complete harmony with the Companies and with the express object of providing an easily worked arrangement between the Companies and the Department.

H.M.

The Witwatersrand Automatic Telephone System

H. A. JOHNSON, B.A. (Hons.).
(P.M.G.'s Dept., South Africa).

Introductory.

“WITWATERSRAND,” usually shortened to “Rand,” is the name of the large gold-producing area centred on Johannesburg and extending for a route distance of some sixty miles from Randfontein in the West to Springs in the East.

The mines produce over £40 million worth of gold per annum, and, in 1930, spent about £30 million on salaries, wages and supplies. It would be difficult to overestimate their importance to South Africa.

Though gold was discovered less than fifty years ago, the days of the mining camps have long since been forgotten, and Johannesburg alone now has a white population of about 200,000, a municipal area of 83 square miles, and a municipally-rated value of nearly £70 million. It has many multi-storeyed buildings, a university, a cathedral and all the amenities of a modern city.

Hand-in-hand with the growth of Johannesburg has proceeded the development of numerous smaller towns along the Rand. These are encroaching upon one another in much the same way as Johannesburg is reaching out to embrace its neighbours, so that in some parts it is difficult to tell where one town ends and another begins.

The headquarters of all the mining groups are situated in Johannesburg, and the community of interest between that city and the various parts of the Rand is such that the area must be treated telephonically as one corporate whole.

Pessimists predict the imminent decay of the area like some of the wonder-cities of the past. They have been doing so for at least twenty-five years! Optimists point to recent striking discoveries of gold reef at the remote ends of the area. Whatever may happen in another twenty-five years, telephone development in Johannesburg has always exceeded that forecast, often with embarrassing results, and adequate provision must be made in the meantime.

A development study of the area showed that extensive provision of equipment would be necessary, and foresight demanded that such provision should be made on a basis which would permit of flexibility in operating over the whole area. With this end in view the Union Government approached the British Post Office for assistance and Mr. J. Innes, B.Sc., was loaned temporarily to the S.A. Department of Posts and Telegraphs in an advisory capacity. The following notes describe the scheme adopted:—

Lay-out of Area and requirements.

At the time when our subject begins, the area contained thirty telephone exchanges grouped into six zones for metering purposes. The majority were

of the C.B. type, but Ericsson rotary automatic equipment was in use in two exchanges and several magneto boards were in service. The junctions varied from open wire to 40 lb. M.T. cable loaded with 135 mH coils. The twenty year forecast showed that approximately 60,000 lines might be expected over the whole area.

The problem was to design the most suitable scheme for serving this development, including zone metering between the six zones with the added possibility of embracing Pretoria (some 36 miles distant) within the network. In the latter event calls were to be completed and metered on an automatic basis.

Investigation of the lay-out showed that adjustment of the exchange area boundaries together with the provision of additional exchanges would be necessary in order to serve subscribers economically. The general lay-out is shown in diagrammatic form in Fig. 1, which also gives the zone metering requirements, while Table I. gives the 1949 development figures for each of the exchanges.

Adoption of the Director System.

If allowance is made for the reservation of levels for service purposes and for the elimination of “ 1 ” as a first digit in subscribers' numbers in view of possible false impulse trouble, the limit of capacity of a five digit numbering scheme can be taken as roughly 70,000 lines. Further limitations are imposed by switching requirements in satellite exchanges and the practical limit is therefore somewhat below this figure. The Johannesburg conditions, however, imposed a further requirement of zone metering and it will be apparent that a mixed five and six-digit scheme or a complete six-digit scheme would be necessary to give the facilities demanded.

The main objection to schemes employing such a number of digits is the subscribers' difficulty in memorising the numbers, with the consequent increased liability of errors in dialling. Further the number of lines in certain of the zones was relatively small and switching and junction provision would clearly be uneconomic under a straight numbering scheme. Examination of alternative proposals showed that a Director scheme employing two code digits would give maximum economy, in serving the area and would give complete flexibility for the future in regard to routing or extension of the area. A two-digit director scheme was therefore adopted, and Table I. gives the code allocations for each of the exchanges in the area. Orders were placed accordingly for the first six exchanges with Messrs. Automatic Electric Co. in March, 1930.

Subscribers' numbers are printed in the directory

thus "33-5678" to help the public to identify the first two digits with a particular exchange. This is further assisted by the allocation of two-digit codes to all exchanges in the area, and no difficulty has been revealed in the use of six numerals by members of the general public.

All junctions from exchanges in the Northern part of Johannesburg from Linden in the West to Edenvale in the East, pass within a few hundred yards of Hillbrow exchange; and the development expected and community of interest, were such that Hillbrow was made a Main exchange with Parkview and Rose-

TABLE I.

Zone.	Exchange.	Proposed type under Auto conditions.	Number of Lines.		Exchange Code.
			1929.	1949.	
C	Central	Main	2993	9400	22
	City	Main	3748	9000	33
	Auckland Park	Satellite	279	1300	31
	Turffontein	on	663	2500	32
	Mayfair	City.	367	1800	35
	Newlands	Rural	50	120	36
	Hillbrow	Main	2271	4700	44
	Parkview		792	2300	41
	Rosebank	Satellites			
	Yeoville	on	633	3300	42
	Orange Grove	Hillbrow.	1563	3300	43
	Bramley		492	2800	45
	Linden	Closed			
	Jeppe	Rural	32	170	46
	Kensington	Main	1513	3600	24
Bedford View	Satellite on Jeppe	571	2400	25	
	Rural	36	100	26	
D	Germiston	Main	705	1500	51
	Boksburg	Satellite on Germiston	382	700	52
	Edenvale	Rural	17	50	53
E	Benoni	Main	792	1900	54
	Brakpan	Satellites on	355	700	55
	Springs	Benoni.	298	800	56
	Petit		10	20	54
	Putfontein	Rural	11	20	54
	Brentwood Park		5	20	57
B	Florida	Main	99	300	62
	Rodepoort	Satellite	164	300	61
	Maraisburg	Closed			
A	Krugersdorp	Main	514	1000	66
	Randfontein	Satellite	104	200	67
F	Sandown	Rural	36	150	48
	Pretoria	—	—	—	71

Grouping of Exchanges.

Once the location of exchanges had been determined, their grouping in the trunking scheme presented little difficulty. The exchanges in the East and West Rand zones (A, B, D, E) group themselves readily into Main and Satellite. Sandown stands apart in a zone of its own, which, for purposes of calls to and from the East and West Rand zones only, is treated as if it were part of the Central zone.

Central is situated at the hub of the junction and trunk network and is an obvious tandem exchange. The new City exchange was necessarily a Main, and geographical and junction considerations caused Auckland Park, Mayfair and Turffontein to be made Satellites upon it.

bank, and probably also Yeoville and Orange Grove, as Satellites. Development may lead to the elevation of Yeoville to the dignity of Main, in which case Orange Grove will become its Satellite.

For similar reasons Jeppe was made a Main with Kensington as Satellite.

Programme of Conversion.

The first six new exchanges, City, Hillbrow, Rosebank, Parkview, Kensington and Auckland Park, were cut-over at midnight on the 26th March, 1932, Kensington working as a temporary satellite on City. At the time of writing arrangements have been made for four more exchanges, Jeppe, Germiston, Turffontein and Orange Grove, to be cut-over

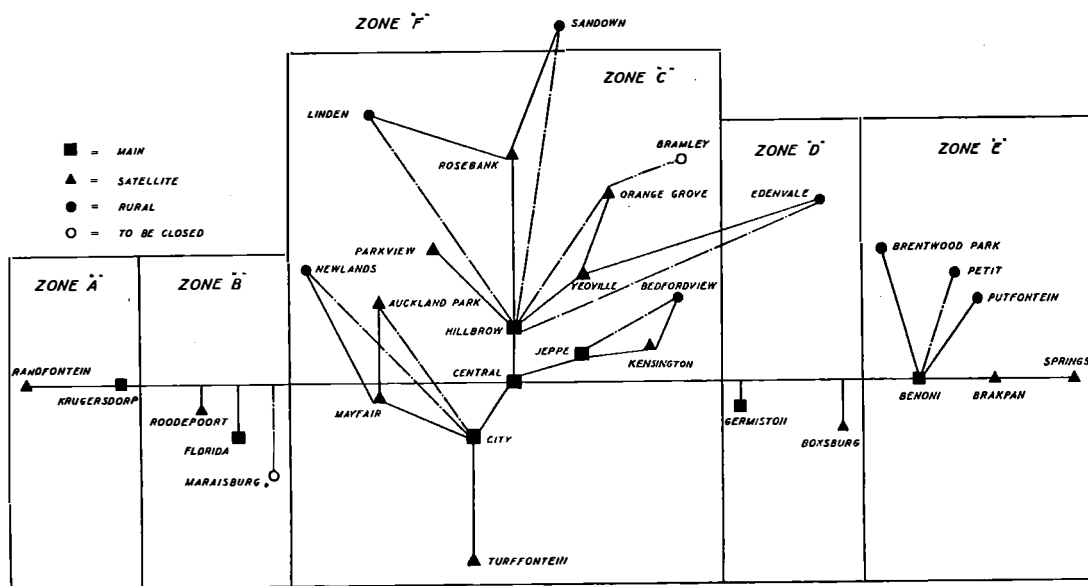

FIG. 1.—LAY-OUT OF AREA.

on 29th April, 1933. A general indication of the conditions obtaining prior to and after these changes has been given in order that the position may be clear to the reader. Many factors enter into the dates of conversion of the remaining exchanges, but the intention is to have all changed over by 1940.

On the opening of the first six exchanges a "more popular" tariff was introduced, namely, £3/12/- p.a. (payable quarterly) plus 1½d. per call. The previous tariff was £7 p.a. for a residential connection (£9 business) plus 1½d. per call in excess of 600 p.a. (900 business).

The result was that the net growth within six months was nearly 3,000, which is 14% of the lines existing and equal to four times the previous growth in normal times. It is certainly the case that residents on the Rand who are connected with mining (and these form the great majority) have felt the depression rather less than others, yet there is severe commercial distress even there, and it is clearly advantageous that the system which has been adopted allows room for considerable expansion at whatever part of the area it may occur.

In this article it will be impossible to describe the equipment in detail, and in view of the familiarity of readers of the Journal with other Director systems it would be superfluous to make the attempt. Attention will therefore be devoted chiefly to features which differ from B.P.O. standard practice.

Routing of Traffic.

Most of the junction groups which had existed under the previous manual conditions remained under automatic working to cope with the large volume of traffic with which automatic exchanges were not concerned, for more lines remained manual after the 1932 cut-over than were converted. But the numbers

of junctions within the groups were considerably curtailed and the circuits thus released helped to provide channels for automatic traffic. In the busy-hour these latter junctions are sufficient for automatic traffic only, but with the 1933 changes arrangements will be made for those manual exchanges which have access to automatic switches, to send all their traffic through them during slack hours, so as to save the staffing of "B" positions at Central at such times. The extra traffic thrown on the switches will not be sufficient to bring the load up to the busy-hour figures.

Economic considerations determined that certain manual exchanges should act as tandems for the routing of traffic to or from automatic exchanges, switching such traffic for less important exchanges which are either in the same zone or else conveniently situated in respect of Junction routes.

Apart from the trunk suite at Central, only the nine most important manual exchanges have direct access to automatic switches. Fifteen exchanges lack such facilities, but all are minor except Boksburg, Brakpan and Springs.

Of these nine exchanges Yeoville is treated as a satellite on Hillbrow, Central has special provision (see below), and all the others dial into City, upon which two, namely, Mayfair and Turffontein, figure as satellites both before and after their conversion.

Jeppe and Germiston become Main exchanges in April, 1933, when the former will relieve City of its present temporary satellite, Kensington. At the same time Turffontein will become an automatic satellite on City, and Orange Grove a satellite on Hillbrow.

When Central is converted the Germiston, Benoni, Roodepoort and Krugersdorp groups of switches

will be transferred from City to Central which will take over the functions of the Tandem exchange for the area. At that time the volume of traffic from and to Brakpan, Springs, and Florida, will probably be so great as to demand the provision of direct junctions to and from Tandem, in which case three new groups of 1st Code Selectors will appear.

The City Trunking Diagram, showing the 1932 and 1933 conditions, appears in Fig. 2. This exchange has junctions to all automatic exchanges,

The conditions regarding Satellites may be summarised as follows :—

- (a) All traffic leaving a Satellite is routed *via* its Main.
- (b) All traffic reaching a Satellite comes from its Main, except that from :—
 - (i) City.
 - (ii) Central.
 - (iii) Trunks.

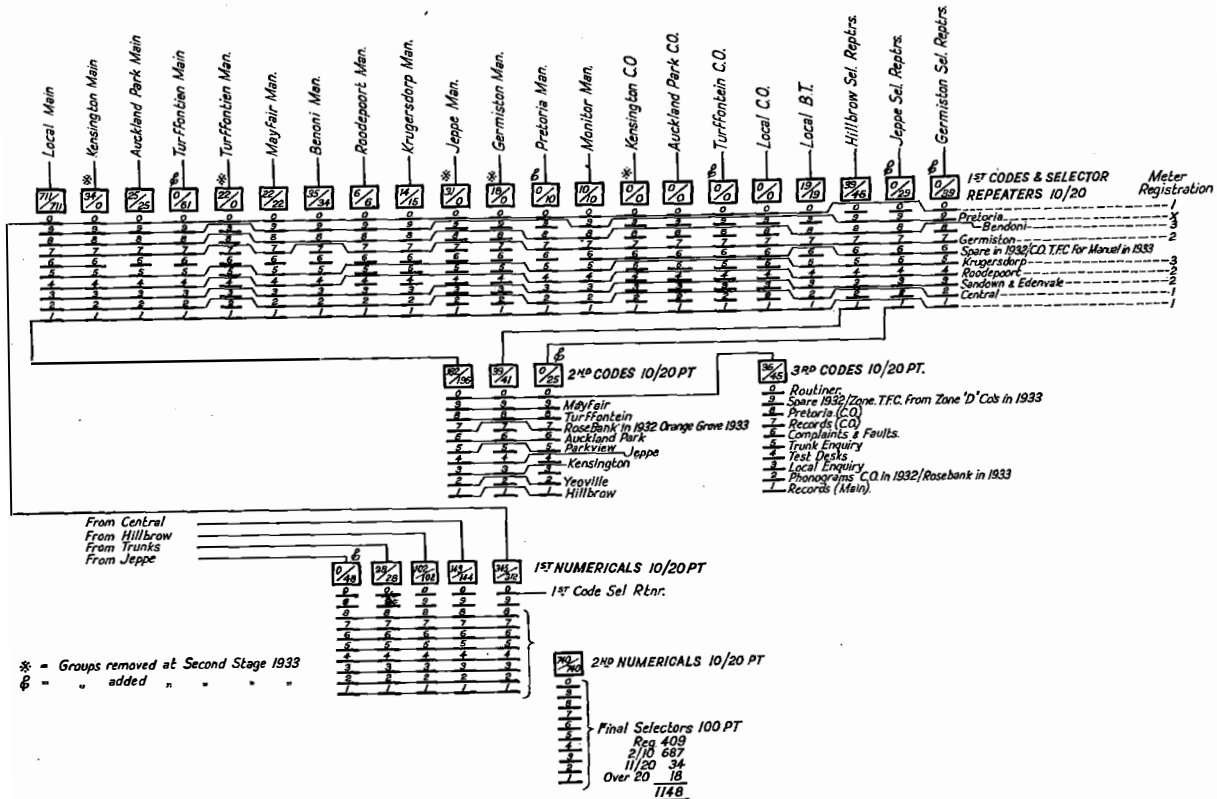

FIG. 2.—TRUNKING DIAGRAM FOR CITY EXCHANGE, 1932/33.

all manual exchanges except those reached *via* manual tandems, and all special services. On the other hand Hillbrow has outlets to its satellites and Central and City only, all other traffic from the Hillbrow group being routed to Selector Repeaters at City and distributed thence. Similarly Jeppe will have junctions to Central, Kensington and City only, and Germiston direct access to Boksburg and Benoni only, all traffic for other destinations from both the Jeppe and Germiston groups being taken to Selector Repeaters at City.

The 1st code selector level marked Pretoria in the trunking diagram represents provision for the time when direct dialling from City to Pretoria will be possible. At present calls for Pretoria are routed *via* an operator at Central, who tickets them.

Each of these three has direct junctions to 1st Numericals at every automatic exchange, (i) and (ii) on account of the volume of traffic, (iii) for transmission reasons.

Modifications at Manual Exchanges.

Those manual exchanges which have access to 1st code selectors, have dials fitted on the A positions. The volume of traffic from Central, however, was too great for this method of disposal, and consequently 4-digit keysenders were installed. As the junctions from Pretoria terminate at Central, Pretoria traffic is also routed *via* these keysenders, though direct access to 1st Code Selectors at City will be provided with the other changes in April, 1933. When traffic conditions warrant it, other

manual exchanges which have junctions to Central (e.g., Brakpan and Springs) also use this channel instead of their normal route to 1st codes at City.

The method of working is that known as the "Straightforward Junction System," and is similar to that described in the Journal for July, 1930, but in the case of Johannesburg, all the equipment is installed in the Central exchange and two-wire junctions are used between Central and the automatic exchanges. Fig. 3 shows the trunking arrangements.

Mounting of Equipment.

All equipment (including auto-manual and manual-auto) is mounted on Single-Sided racks with channel-type shelves. As with the B.P.O., these racks are 4 ft. 6 ins. wide except for Routiner (1' 4 1/2") Special Apparatus (2' 0-5/8") and Alarm Equipment (2' 6 1/4") racks. The racks are, however, 11 ft. 9 ins. high in all cases, except where an existing building has restricted the height to 10 ft., as at Hillbrow and Jeppe.

The Line Finder racks are mounted in close proximity to the Final Selector racks, and line I.D.F. facilities are provided at the rear of the latter by means of five 20 x 9 point tagblocks per group of 100 subscribers' lines. Where the number of the line relay is the same as the number in the Final Selector Multiple, a "straight connection" is made by bare wire strapping of the relative tags. Omission of these straps and the running of jumper wires

enables any L. & C.O. relays to be associated with any Final Selector contact, so that a subscriber may be transferred from one Line Finder group (and therefore 1st Code or D.S.R. group) to any other group required.

The provision of line I.D.F. facilities at the rear of the racks, results in a considerable diminution in the cabling and in the size of the central I.D.F. On this latter the Line Finders are cross-connected to D.S.R.'s or 1st Codes, as the case may be, so that the load on these switches may be distributed evenly and varied as necessity arises. The only other lines appearing on the central I.D.F. are the junctions, and routiner and supervisory lines. The largest I.D.F., that at City, had 13 verticals initially and is expected to have 15 ultimately. It occupies a space 3 ft. 9 in. by 6 ft. 6 in.

Grading.

Similarly all grading is done on tagblocks on the rear of the racks. The bank multiples are terminated on tags on one side of the block and bare wire commoning for grading is done on the tags on the other side. Multiple cables from the previous and following racks are run to the same blocks, so that the commoning may be extended over all racks if required. Outgoing trunk tagblocks are fitted at intervals, and from them cables are run to the next rank of switches. In those cases, relatively few, where the grading requires that a switch in the next rank be reached from a rack which has neither a direct outgoing trunk to that switch nor access *via* the multiplied commoning mentioned, the necessary connection is made by running a jumper from the terminal on the bank tagblock to the appropriate terminal on the outgoing trunk tagblock. Fig. 4 shows the details of the grading arrangements, and Fig. 5 is a rear view of a typical rack.

Line Finders.

The Line Finder is a two-motion selector with three sets of wipers hunting over 200 pt banks (so that it serves a group of 200 subscribers' lines) and a vertical wiper operating over a 10 pt bank attached to the shaft.

When a call is originated the level in which the calling line is situated is "marked" by earth on the vertical bank, and the contact in the 200 pt private bank is "marked" by the absence of earth. Both these conditions, as well as the starting of the hunt, are brought about by the operation of the calling subscriber's line relay. His line is found and put through to a 1st Code Selector (*via* a D.S.R. if a satellite is concerned) and Director before dialling-tone is given.

If a Line Finder fails to establish connection with the calling line within three

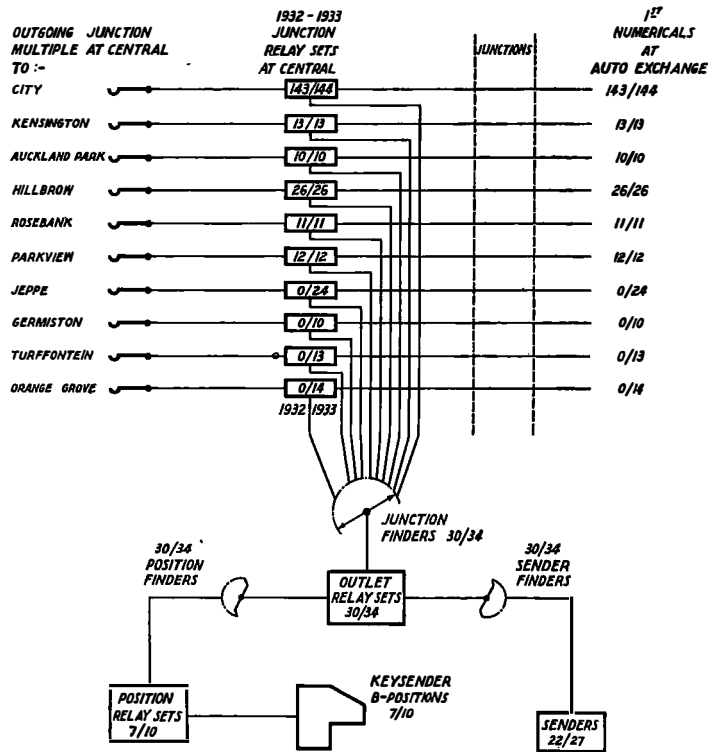

FIG. 3.—KEYSENDER TRUNKING DIAGRAM.

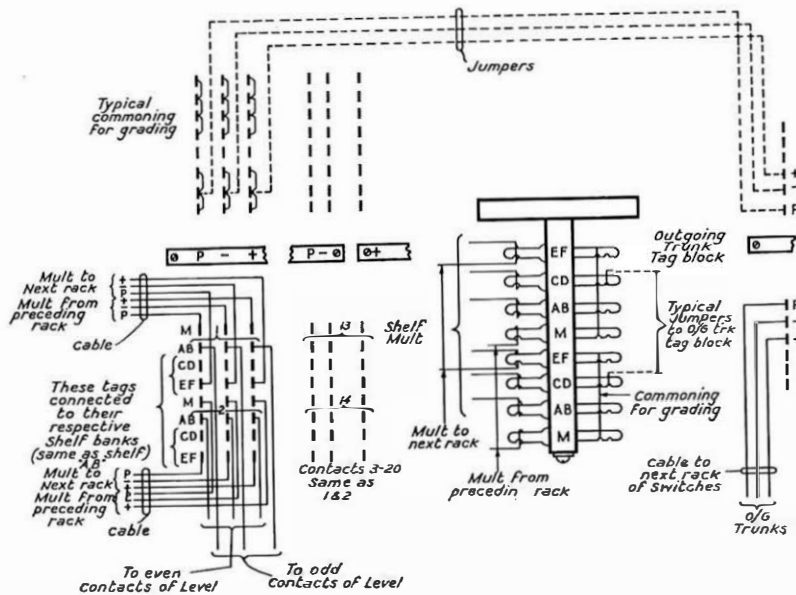

FIG. 4.—GRADING OF 10/20 GROUP SELECTORS.

- (1) To return the mechanism to normal, through the operation of the Local Discrimination Relay, when the local code is dialled;
- (2) To provide for zone metering, the number of registrations depending upon the position of the P1 wiper in the bank.

The switch also has a vertical bank and wiper on the shaft, giving absorption of a false preliminary impulse and providing for single fee metering on 0 level calls. This latter feature is not used in Johannesburg, but the vertical bank will assist the introduction of "Demand" working,

seconds, it is automatically thrown out of service—as is its associated distributor—and an alarm given.

The Line Finders provided for a group of 200 subscribers' lines are divided into two sub-groups, each of which has associated with it one distributor (an eight level rotary switch with 9 relays) which preselects the line finders, allocating calls to them in sequence and distributing the traffic evenly over the whole.

An important feature of the system is what is known as "Preferential Hunting." All banks provided for a group of 200 subscribers are multiplied, but midway the multiple is reversed, both horizontally and vertically, so that those lines which appear in levels 1 to 5 in the first half of the multiple are transposed to levels 6 to 0 in the second half and vice versa. Thus every line in the 200 appears in one of the lowest five levels in half the multiple, and each sub-group of 100 lines is first choice (or "Preferred Lines") to one half of the total number of Line Finders, and only when all those switches are in use do any of the others serve them at all. Each distributor with its allotment of Line Finders thus works virtually as an independent unit and deals only with the subscribers grouped on the lowest five levels. But when all the finders in one sub-group are busy, the other distributor automatically serves the whole 200 subscribers until a finder is freed in the busy sub-group.

A key is fitted for throwing either distributor out of service for test or adjustment, meanwhile its companion takes the whole load.

Discriminating Selector Repeater.

The switches are all 10 point, but the private bank has double contacts. The P1 contacts serve two purposes :—

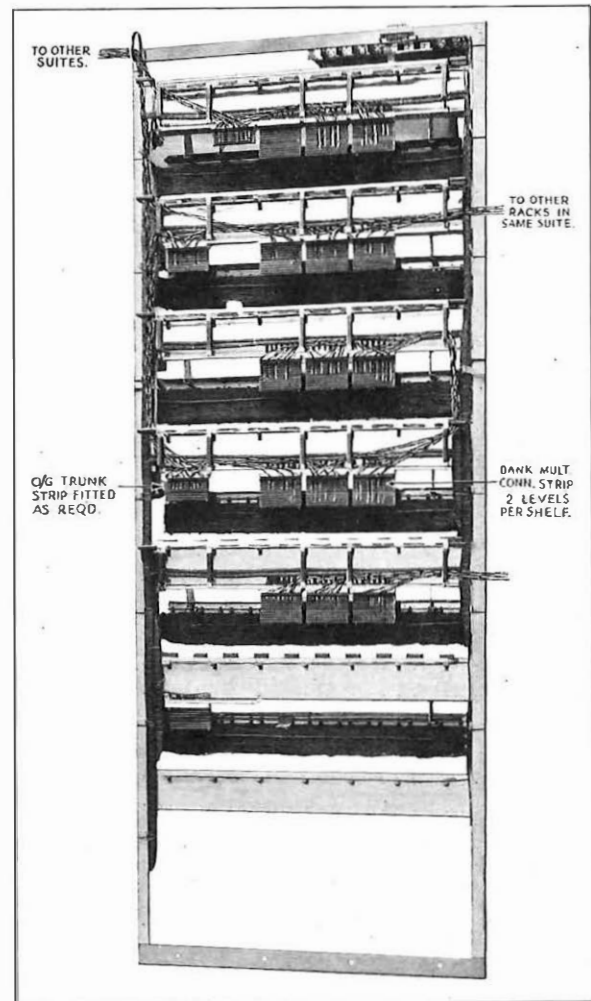

FIG. 5.—REAR VIEW OF TYPICAL SELECTOR RACK.

which is at present under treatment, and direct switching to adjacent exchanges if and when traffic warrants such provision. At present the D.S.R.'s do not provide such direct switching as it is not justified.

Director.

As the code consists of two digits only, A Digit Selectors are not used and the Directors are all in one common group instead of being split up according to a particular initial digit. The Director Finders are associated with 1st Code Selectors.

No "minor" switches are used, all rotary switches being of the ordinary type. The Digit Distributor used in the London type Director has been dispensed with by the addition of the function of digit distribution to the Units register.

The "BC" switch has a vertical bank and wiper to cater for cases where a false preliminary impulse is received ("BC" switch releases and circuit remains ready for receipt of dialled impulses), or for cases where "0" is dialled (to connect the "BC" switch wipers to the "CO" translation tags, start the sender and route the call to the "Local Enquiry" operator).

The Director assembly consists of two parts, the upper containing the control relays and the storage switches, and the lower, the "BC" switch and the translation field.

Certain of the functions which are associated with the 1st Code or A Digit Selector in the London system, on the Witwatersrand are associated with the Director, namely:—

- (1) Dialling tone is normally given by the Director.
- (2) Absorption of false initial impulse.
- (3) Forced release under dialling irregularities.

1st Code Selectors.

These are all 20 point. The functions are similar to those of the London type, though some have been embodied in the Director instead. The circuit has been modified to cater for the association of a Director Finder in place of an A Digit Selector Finder, and except in satellite groups the switches are equipped with a vertical bank and wiper on the shaft and additional relays for zone metering.

The switches are of three types:—

- (1) Regular (subscribers), 16 relays and vertical bank.
 - (2) Satellite, 13 relays. No vertical bank.
 - (3) Manual, 16 relays. Vertical bank.
- (1) Each switch of the regular type is tied to a Line Finder by jumpering at the I.D.F.
 - (2) Satellite switches terminate junctions from satellite exchanges, and when the callee answers give battery reversal over the junction for metering at the originating exchange.
 - (3) The manual switches terminate junctions from all those manual exchanges (other than Central) which dial into the automatic system. These selec-

tors give battery reversal for supervisory purposes when the callee answers. They have been designed so as to be readily converted to the regular type when the manual exchanges disappear. In the meantime the vertical bank is not used.

Final Selectors.

(a) *Private Branch Exchanges:* All P.B.X. Final Selectors are of the 100 outlet type, and incorporate a P.B.X. arc and trailing wiper similar in principle to that used in the Siemens No. 16 system. The selector for P.B.X. groups with more than 10 lines has a rotary release magnet in addition and is thus a 1 to 100 line switch. Hunting for the first free line amongst those of a particular group is automatic if the first number in the group, or in the case of the over 10 line type if the first number in a level is dialled. Any other line than those mentioned may be used for night service.

(b) *Test and Trunk Offering.* One Final Selector per group combines the functions of Test and Trunk Offering, being accessible to both the Test Distributor and the Trunk Offering Distributor.

For trunk offering purposes the operator jacks into a junction leading to a T.O. Distributor at the exchange concerned and dials the first two digits of the four which represent the subscriber's number (the two code digits being absorbed by the jacking process). She then pauses to see if busy tone is returned and if not dials the remaining digits. The receipt of busy tone indicates that the Test Desk is using the T. & T.O. switch, and simultaneously with the supply of busy tone to the operator the Test Clerk receives a flashing "clear for trunks" signal and releases. The operator then proceeds with her dialling. As stated elsewhere the modification of present trunk working to permit "Demand" working is now under treatment. The probability is that the method of "offering" will be modified at the same time to enable the trunk operator to complete the trunk connection over the circuit which she uses to offer the call, a condition not at present possible.

(c) *Release.* A connection is released by the last party to clear. When the calling party clears, all switches release except the Final Selector.

If the callee clears first he releases the D relay of the Final Selector and this reverses battery back to the D relay of the 1st code which the caller is holding, and brings up the "called sub held" alarm. The release of the Final Selector D relay also gives a supervisory alarm on the Final Selector.

This control of the release, *i.e.*, the retention of the Final Selector until both subscribers have cleared, prevents clearance by the calling party before the called, from converting the callee into an involuntary caller with the concomitant operation of his line relay, a distributor, a line finder, a 1st Code and a Director, as well as a D.S.R. and the seizure of a junction if he happens to be at a satellite exchange.

Zone Metering.

During the initial stages the maximum number of

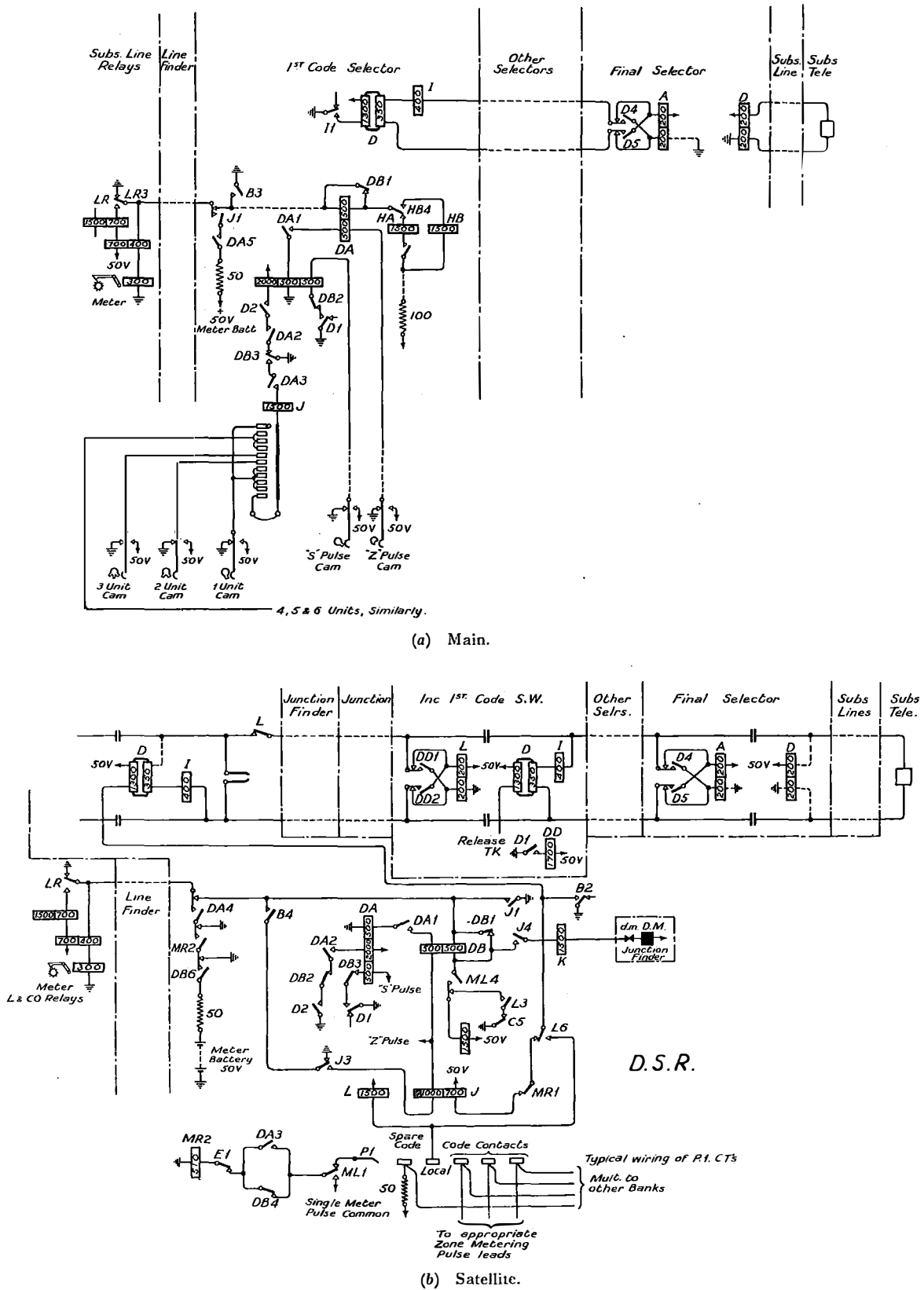

FIG. 6.—SCHEMATIC DIAGRAM OF METERING ARRANGEMENTS.

meter registrations required is four (Germiston to Randfontein and Krugersdorp). But provision has been made in the metering scheme for six registrations, so that automatic metering can be given on calls to Pretoria when conditions permit the introduction of direct dialling. At present the number of circuits available is insufficient.

Zone metering at main exchanges is achieved by the use of a vertical bank and wiper associated with the 1st Code Selector, the selector levels being allocated in accordance with the plural metering scheme. In the satellite exchanges the P1 wiper and contact on the D.S.R. effect the metering discrimination. The levels on the 1st code vertical bank and the P1 contacts on the D.S.R. are wired out to the various pulse commons.

The subscriber's meter is actuated through the application of "S" and "Z" pulses. When the called subscriber replies, an "S" pulse (alternate long earth and short battery) prepares the metering circuit of the 1st Code or D.S.R., and a "Z" pulse (alternate long battery and short earth) completes this circuit. Battery pulses then operate a relay in the 1st Code or D.S.R. which connects meter battery to the private wire to operate the meter. The number of battery pulses applied is governed by the pulse common associated with the level on which the 1st Code Selector is standing, in the case of a main, or the particular bank contact on which the P1 wiper rests in the case of a satellite, *e.g.*, when a Parkview subscriber calls Hillbrow the P1 wiper of the

D.S.R. which he is using stands on contact 44 and there picks up a single pulse common. If he calls Sandown, however, the P1 wiper stands on contact 48 and there picks up a 2 pulse common.

The "S," "Z," and various battery pulses are generated by cams and springs on a small jack-in type motor. A standby meter pulse machine group is fitted at each exchange and is brought into service automatically if a fault develops on any of the pulses from the regular machine.

The meter battery is a small capacity 50 volt battery with the negative earthed. It is applied in place of the release trunk to actuate the meter.

A schematic drawing of the circuit arrangements is given in Fig. 6.

Power Arrangements.

The full-float method of energy supply has been adopted. This system uses only one battery paralleled or "floated" across the generators which supply the exchange load. Two machines have been installed at each exchange, but provision has been made for the addition of a third later at City and Hillbrow. These two machines do not give identical outputs, the arrangement being that both machines together supply the busy load, and one or other may be cut out of service as the load drops. The generators are of the telephone type and are used with choke coils, so that they can maintain the exchange without the aid of the battery. They are compound wound (for maintenance of exchange voltage be-

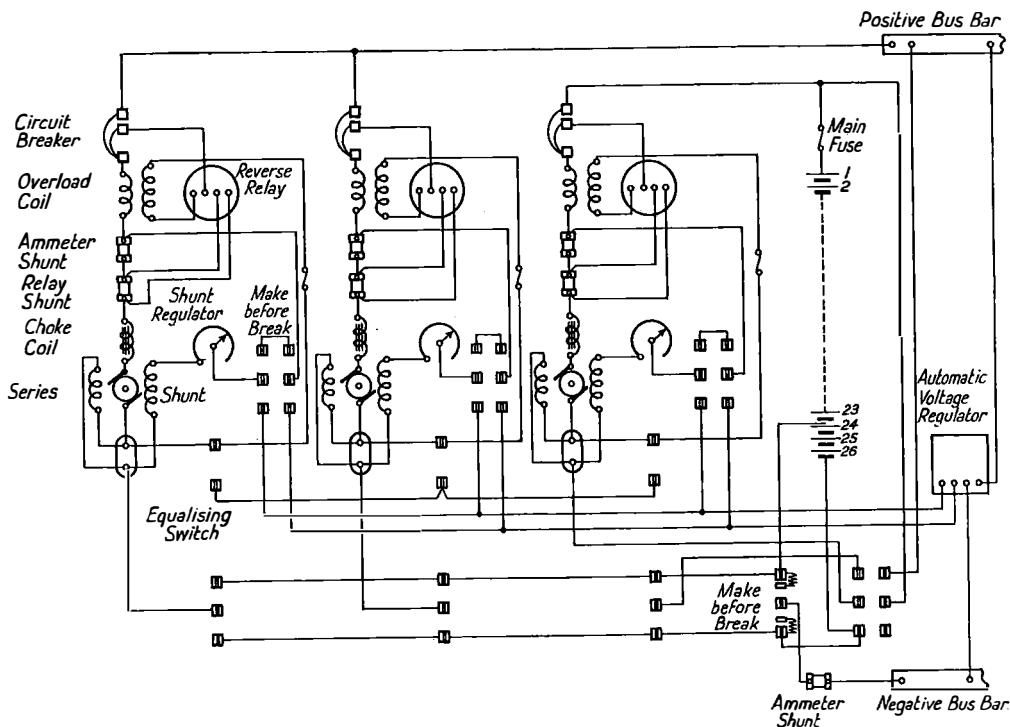

FIG. 7.—SCHEMATIC DIAGRAM OF FULL FLOAT BATTERY SYSTEM.

tween 46 and 52 when the machines are supplying the exchange without the battery) and can be converted to shunt for charging after failure of mains supply, and for a six monthly overcharge of the battery.

The battery contains 26 cells whose capacity is computed at five times the busy hour load, but the last three cells are used only after a power supply failure or if no generator is run at night, when all the 26 cells may be required for the night load. The normal method of working is to maintain 23 cells across the generators, with an automatic voltage regulator maintaining the individual cell voltage at 2.15.

A schematic diagram of a typical power circuit is shown in Fig. 7.

Power Distribution.

Battery and earth are supplied to the racks by aluminium bus-bars, and at City, Hillbrow and Jeppe the feed is taken *via* a small circuit-breaker at the end of each suite of racks. At the seven other exchanges circuit-breakers are not used. Exposed portions of the negative bus-bars are covered with insulating material. At each rack, vertical bus-bars connect with the overhead commons. Bead fuse panels and other supervisory equipment are mounted on the uprights of the racks.

Miscellaneous.

The supervisory and alarm scheme is in general accordance with B.P.O. standard practice, but the alarm extension arrangements use one special junction for both " Prompt " and " Deferred " alarms. Test Desks of the B.P.O. type are installed at main exchanges and test cases at the satellites. Routiners have been provided for Directors, 1st Code, Group and Final Selectors and provision is made for testing junctions for continuity reversal and short circuit. The B.P.O. standard scheme for Travelling Ladders has been adopted at all exchanges and flood lighting is being provided in the second stage exchanges.

Installation.

The whole of the installation work was carried out by the Department's staff, the automatic portion being under the control of Messrs. Automatic Electric Co. who provided five installers to direct operations. Very considerable cable works had to be carried out simultaneously, and the magnitude of the joint programme, at a time when expenditure was being ruthlessly curtailed, taxed the staff to the utmost.

In conclusion, the author desires to express his thanks to the Postmaster-General, South Africa, and to Messrs. Automatic Electric Co. for the permission and courtesy extended to him in preparing the material and illustrations for publication.

Country Satellite Exchanges

H. O. ELLIS and B. WINCH.

IN numerous rural districts throughout the country it is necessary, both from a social and commercial point of view to provide telephone service to small groups of subscribers which are frequently found to be centred round a village or hamlet. The fact that these groups are frequently many miles from an existing exchange precludes, from an economical point of view, the use of a direct exchange line to each subscriber, particularly as from a transmission aspect, heavy gauge conductors are involved.

In the past, the Department has served these areas in three distinct ways :—

- (1) By a small Manual Exchange situated as nearly as possible at the theoretical centre of the group of subscribers.
- (2) By a small Unattended Automatic Exchange similarly placed.
- (3) By a " Party Line."

The provision of a Manual Exchange involves the problem of obtaining accommodation for the manual board and subsidiary apparatus, and of finding a

suitable operator. These exchanges are frequently installed in a private house, where the resident operates the board.

A Rural Automatic Exchange, while overcoming the necessity for a local operator and providing a good grade of service, demands a special building to house the equipment, power plant, etc., a factor which materially influences the cost of providing service to a small group of subscribers.

An alternative to the use of a small local exchange lies in the joint use, by all subscribers, of one direct line to the nearest exchange. This arrangement is well known as a Party Line Service. In an area such as that under consideration the scheme can be shown as in Fig. 1.

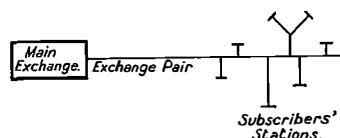

FIG. 1.—PARTY LINE SERVICE.

The pair of wires to each subscriber is connected to the main exchange pair at the nearest convenient point, so that all instruments are in parallel across the main exchange circuit.

This method of providing service is characterized mainly by its simplicity in that no special apparatus is required at the exchange, whilst only minor modifications to the subscribers' instruments are involved.

Against this, however, is the disability that no secrecy between subscribers in the group is given. Furthermore, for calling purposes, approximately half the subscribers' bell circuits are associated with the A-wire, and the remainder with the B-wire, earth being used to complete the ringing circuit. Hence a number of bells respond when any one subscriber is being called. To distinguish between them each subscriber is given a ringing code, and he should not answer a code other than his own. Apart from misunderstandings likely to arise from subscribers mistaking the number of ringing pulses, and thus obtruding on a fellow subscriber's conversation, the disturbance at night time to others in the group, by traffic to one man may easily reach serious dimensions. Frequency ringing may be employed as a means of obviating this nuisance, but the provision of a suitable generator at the exchange, and selective apparatus at each subscriber's premises considerably influences the economics of the scheme.

During investigations into the circuit requirements involved in the development of certain telephone facilities, a principle was evolved by the Department, which, on being developed, was found to be eminently suitable for providing service to small rural communities without any of the disabilities of the schemes mentioned above.

In this scheme the theoretical centre of the group of subscribers is determined in the usual manner. At the nearest convenient position to this point is located a miniature telephone exchange which consists of twenty-four standard type P.O. relays and a small quantity of miscellaneous apparatus.

Each subscriber is connected to this exchange by the usual pair of wires, whilst a two-wire junction circuit to the nearest main exchange provides the traffic outlet. This junction also provides the circuit for controlling all the functions of the "Country Satellite Exchange," thus obviating the necessity for any local battery at this exchange. This fact, together with the small quantity of apparatus involved, enables the "Exchange" to be mounted on a jacked-in basis, and contained in a weather-proof box, which, being of small dimensions, may be mounted on a telegraph pole. The accompanying photographs, Figs. 2 and 3, show four views, and give some idea of the size of a box which is being experimented with as a suitable container. From Figs. 4 and 5, it will be seen that these boxes are not unsightly, and are easily accessible when mounted in position on a pole.

Since the parent exchange controls all the func-

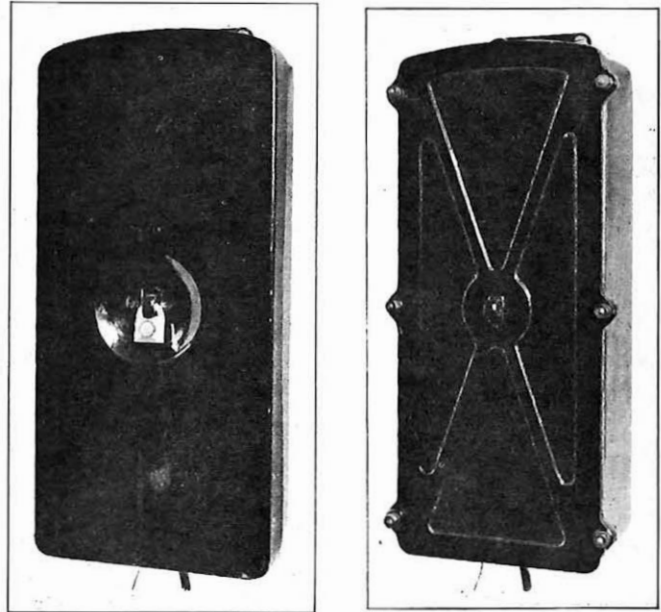

FIG. 2.—EXTERNAL VIEW OF RELAY-SET BOX.

tions of the country satellite, it is necessary for each subscriber's number to have an appearance in the parent exchange multiple. An answering jack and lamp, common to all the satellite subscribers, are also provided at the parent exchange. All subscribers are normally connected in parallel to the junction, but the parent exchange manual board equipment is associated with apparatus which automatically controls, over the junction, the relays at the country

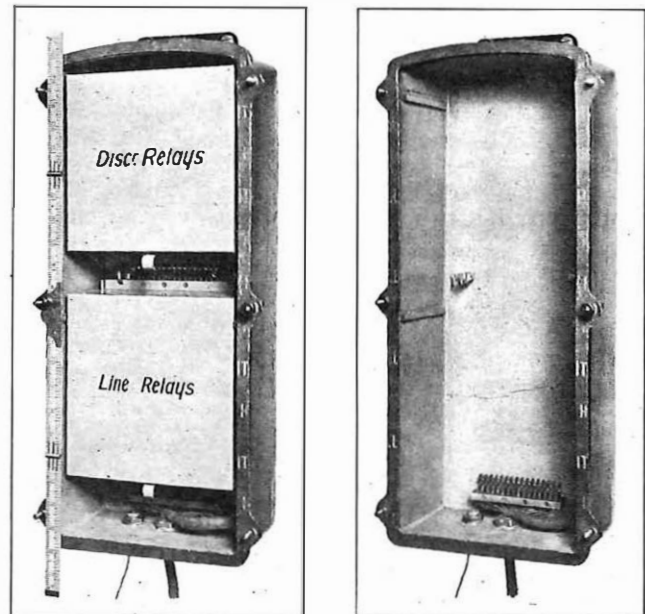

FIG. 3.—RELAY-SET BOX OPEN.

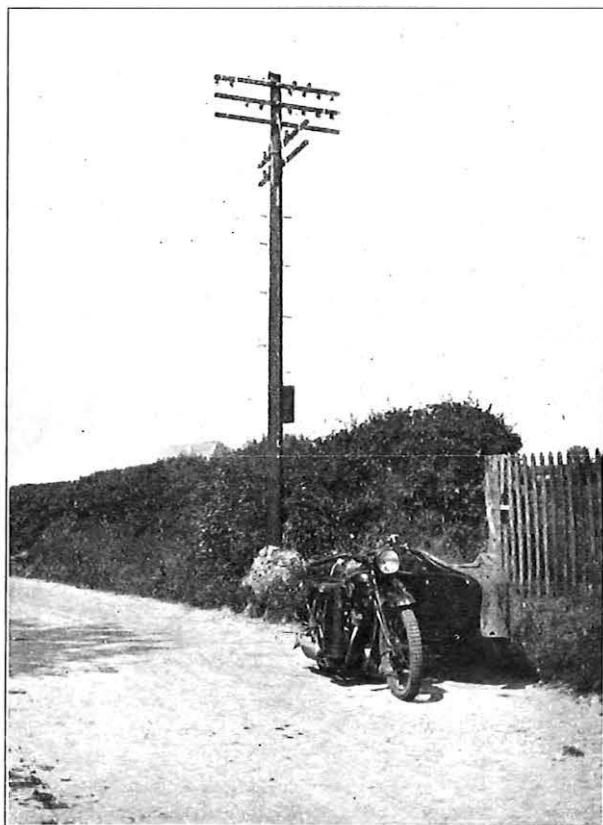

FIG. 4.—POLE WITH RELAY-SET BOX IN POSITION.

satellite exchange, providing for the selection of the subscriber who is concerned on an incoming or outgoing call, and disconnection from the junction of all others in the group.

It will be obvious, therefore, that no special ringing arrangements are required either at the satellite or parent exchange, whilst the complete disconnection of all subscribers but the one required ensures secrecy to that individual. The requirement that two subscribers on the satellite exchange may wish to communicate has not been overlooked, as a special intercommunication jack on the manual board provides a means of controlling this type of call.

Before proceeding with a description of the circuit a resumé of the operating procedure may perhaps be of interest.

When a subscriber lifts his receiver to originate a call, a tone is received if the junction is free. A calling signal is given on the manual board at the parent exchange. The operator answers, and the insertion of her plug into the common answering jack extinguishes the calling signal and disconnects the tone. The caller's requirements are ascertained, together with his own number, which is required for accounting purposes. If the required subscriber is not connected to the same country satellite exchange the call is completed *via* the calling cord in the

normal manner. When the called and calling subscribers are both connected to the same exchange, the operator, after answering, inserts the calling plug into the multiple jack of the required subscriber, and removes the answering plug from answering jack. This operation disconnects the calling subscriber from the junction and selects the called subscriber who is rung from the calling plug in the normal manner. When the called subscriber answers, the operator inserts an answering plug into the intercommunication jack, thus reconnecting the calling subscriber to the junction, and therefore to the called subscriber.

Calls incoming to the satellite subscribers are completed over the multiple jacks in the standard manner. The act of inserting a plug into the jack selects the required subscriber's line at the satellite exchange and ringing is applied *via* the calling cord.

Fig. 6 shows the circuit and equipment required at the parent exchange and Fig. 7 that necessary at the satellite.

The satellite equipment can be roughly divided into two portions, namely, relays individual to subscribers, A A, B B, etc.; and discriminating relays A, B, X, XX, etc. The discriminating relays are arranged in three groups. Relays A, B and C control subscribers 1, 2 and 3, whilst relays X and XX

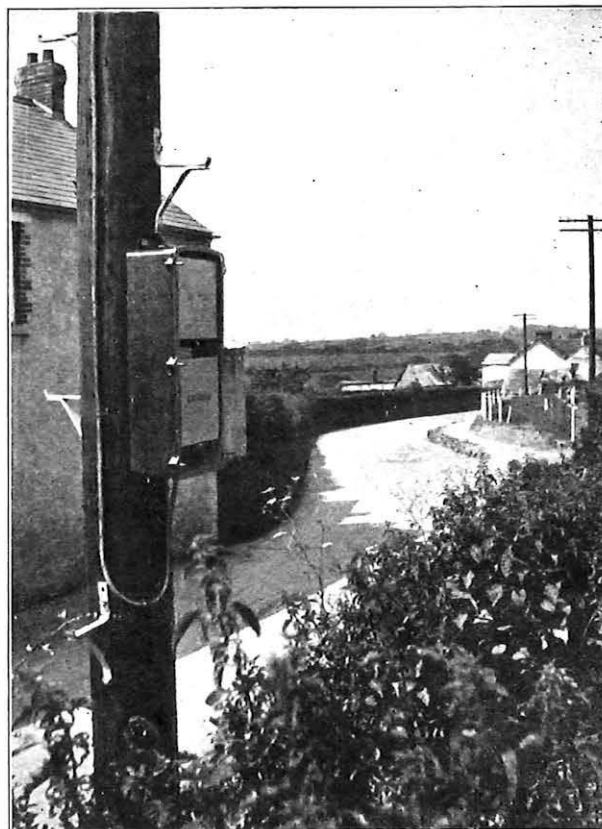

FIG. 5.—RELAY-SET BOX ON POLE.

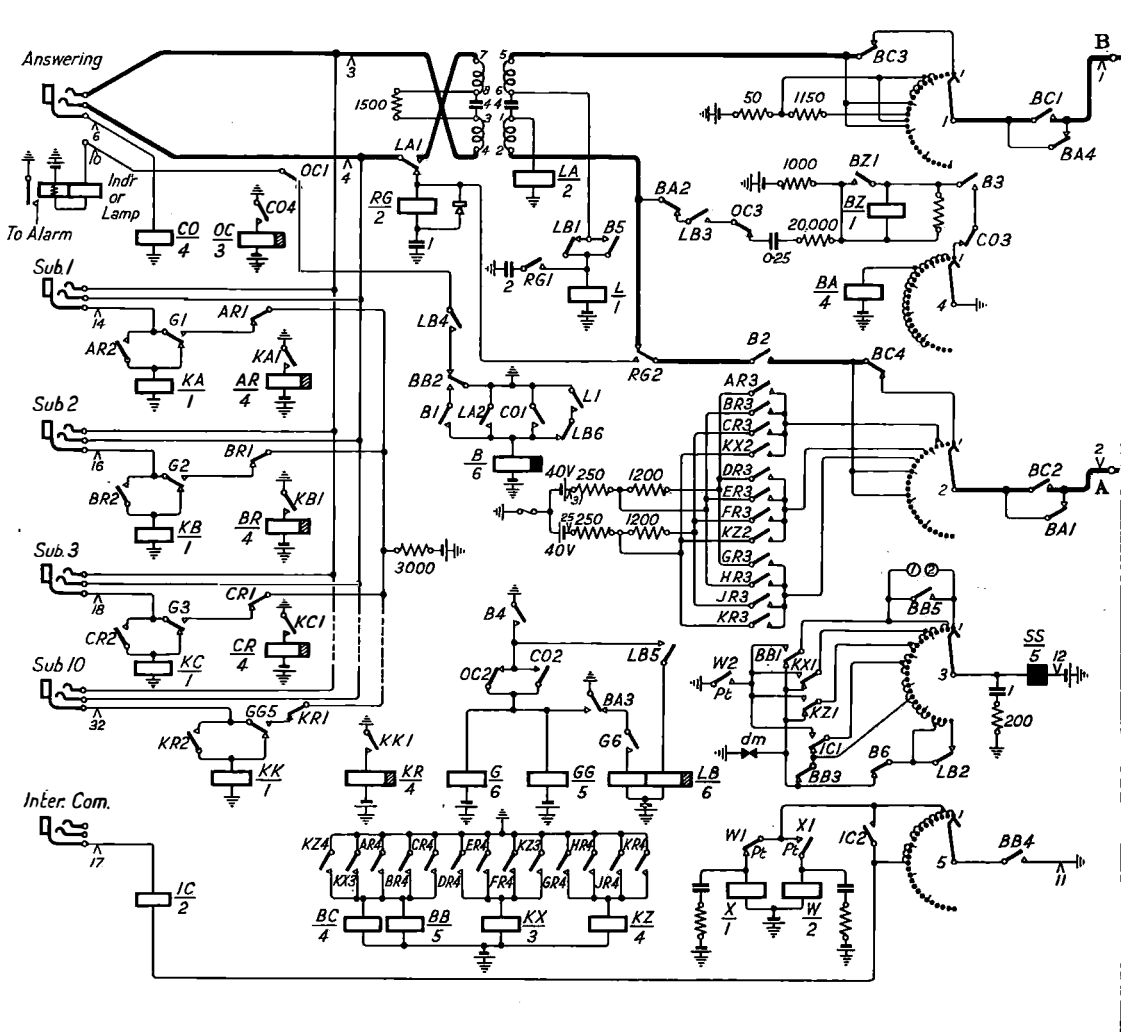

FIG. 6.—PARENT EXCHANGE CIRCUIT.

divert the discriminating signals into the second group. Similarly relays D, E and F control subscribers 4, 5 and 6, and relays Z and ZZ divert discriminating signals to the next group where subscribers 7, 8, 9 and 10 are controlled by relays G, H, J and K respectively.

At the parent exchange, in addition to the relays associated with the sleeves of the jacks, is provided a uniselector, the bank contacts of which are so arranged that various sequences of discriminating signals can be applied to the junction, while the switch wipers are stepped under control of slowly interacting relays X and W (Fig. 6).

In order to simplify the circuit description of an outgoing call, assume Subscriber No. 1 is an originating party. When he lifts his receiver a circuit is completed from earth (Fig. 7) via relay AA, contacts AA2, subscriber's lines and telephone, contacts AA1, C1, A1, etc., to the B-wire of the junction, contact BA4 (Fig. 6). Bank contact 1, BC3, LB1, to battery via relay L. Relays AA and L operate,

the former locking via contact AA4 to the B-wire of the junction via B1, ZZ2, XX2 (Fig. 7). The contacts AA1 and AA2 disconnect the operating circuit of relay AA, and connect the subscriber's line to the junction pair. Contact AA3 disconnects the discriminating relays A, B, etc., from the A-wire of the junction, whilst AA5 breaks the common wire to which all subscribers are normally connected in parallel.

Relay L (Fig. 6) operates relay B, which at contact B4 operates relays G and GG, thus applying engaged conditions to the sleeves of all the multiple jacks associated with the satellite subscribers. Contact B2 connects relay LA to the A-wire of the junction, and B3 starts the tone generation relay BZ. Relay LA operates round the subscriber's loop; contact LA1 disconnecting the RG relay from the "ring" of the answering jack, and completing a loop across the tip and ring of this jack for supervisory purposes. Contact LA2 covers the operation of contact LB6.

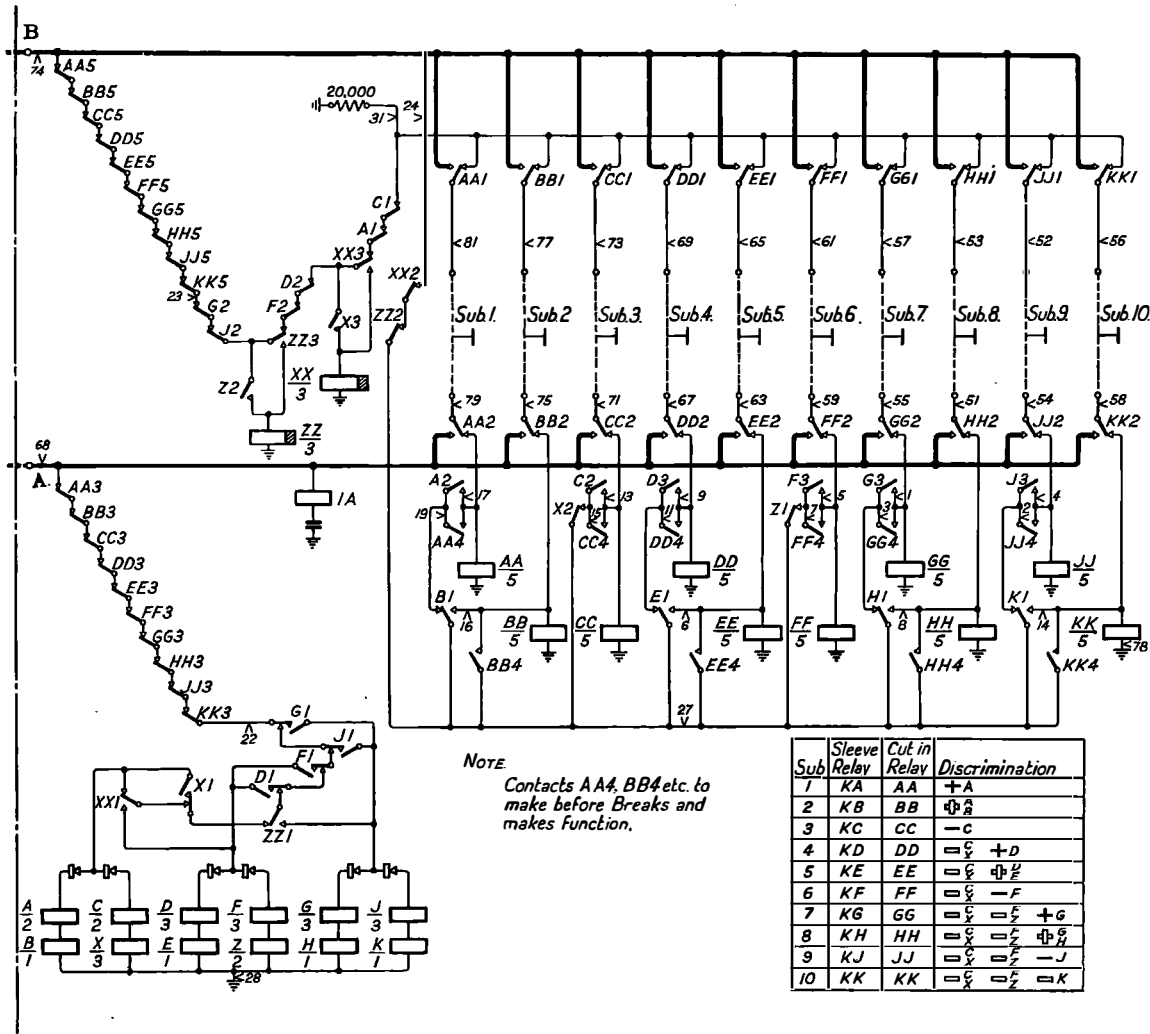

FIG. 7.—10-LINE COUNTRY SATELLITE EXCHANGE.

Relay LB is operated by relay G at contact G6, and locks under control of relay B at LB5. The circuit for the calling signal is completed at LB4, whilst LB3 applies the tone to the A-wire of the junction to indicate to the subscriber that he has claimed the junction.

Upon the insertion of a plug in the answering jack, the sleeve relay CO operates and at contact CO1 holds relay B, and at CO2 provides an alternative circuit for holding relays G and GG. The tone is disconnected from the line at contact CO3, and at CO4 relay OC is operated. Relay OC extinguishes the calling lamp at OC1 and contact OC3 removes the tone generating equipment from the A-wire. The operator is now in a position to speak to the calling subscriber, and normal supervision is obtained on the answering cord, controlled by relay LA, which in turn is under the control of the subscriber's gravity switch.

When the subscriber clears, relay LA releases, giving clearing conditions at contact LA1. When

the operator withdraws her answering plug, relay CO releases, thus releasing relays B and OC. Relay L is disconnected from the B-wire by contact B5, since relay LB is still operated, and hence, since battery is disconnected from this line, relay AA at the satellite exchange releases, while further calls cannot be originated until relay L is reconnected, which occurs after the release of relay LB by B4 breaking. Relays G and GG are also released, thus removing the engaged condition from the multiple.

In considering the circuit functions for an incoming call, assume subscriber No. 10 is required.

Upon the insertion of a plug in the multiple jack of No. 10 subscriber, relay KK and its relief relay, KR, operate. The latter at contact 2 provides a locking circuit for relay KK, whilst KR3 applies a low resistance negative battery to contact 8 on arc 2 of the sequence switch. Contact KR4 operates KZ which in turn operates KX. Relay KX operates relays BC and BB. Relays X and W commence to interact with the closing of contact BB4. Contact

W₂ energizes the magnet, and steps the sequence switch *via* BB₅ and BB₁ to bank contact 10, under control of contacts KX₁ and KZ₁. When the wipers leave the first contact of the banks of the sequence switch, the A and B wires to the junction are disconnected, and relay BA is operated. Contact BA₃ operates relays G and GG to engage the multiples of the remaining nine subscribers. Contact BA₂ disconnects the tone circuit from the junction line.

From bank contacts 3 and 4 on arc 2 of the sequence switch, a low resistance negative battery is applied to the A-wire, and hence *via* contacts AA₃ (Fig. 7), etc., to relays A and B, C and X. A heavy negative battery is arranged, in virtue of the location of the rectifiers, to operate relays X and C. In passing, it may perhaps be pointed out that a "light" negative battery would operate relay C only. This principle of light and heavy batteries applies similarly to the other pairs of the discriminating relays. Contact C₁ disconnects the subscribers' common from the B-wire of the junction, whilst contact X₃ prepares a circuit for relay XX. At contact X₁ an alternative circuit to hold relays C and X is provided, against the operation of XX₁.

When the switch reaches the fourth position, relay XX is operated from 50-ohm battery, arc 1 of the sequence switch and the B-wire of the junction; contact XX₃ disconnects the common, as contact C₁ will shortly be restored to normal. XX₃ also locks its parent relay to the junction line. Contact XX₂ disconnects the circuits to relays AA, BB, etc., to prevent relay CC being operated during the next stage of the call. The switch moves to the fifth contact at which on arc 1 relay XX is held operated, and on arc 2 relays X and C are released. It will be seen therefore that since XX₁ is operated and K₁ released, the A-wire is extended to the second group of discriminating relays.

Upon the wipers reaching the sixth position, heavy negative battery is applied *via* KZ₂ to the A-wire to operate relays F and Z. Contact F₂ releases relay XX, at the same time disconnecting the subscribers' common. Contact Z₁ prevents contact F₃ from completing a circuit for the operation of relay FF, whilst F₁ functions similarly to X₁ to change over to the next group of discriminating relays. Relay ZZ is operated by contact Z₂ over the B-wire and locks *via* ZZ₃, which also disconnects the subscribers' common against the release of contact F₂.

Relays F and Z are released when the switch steps to the seventh position, and ZZ₁ operated in conjunction with the release of F brings into circuit the last group of discriminating relays.

As subscriber 10 is required, it is necessary to operate relay KK (Fig. 7) and to this end KR₃ has already prepared a circuit for a heavy negative battery on the eighth position of arc 2, to which the wipers are now stepped. Relays J and K operate in series, but it will be observed that K, while preventing J₃ from operating relay JJ, prepares a circuit for relay KK. This relay is operated on the

release of relay ZZ *via* ZZ₂ and XX₂ to the B-wire. Contact J₂ releases the ZZ relay. Contact KK₃ disconnects the discriminating relays from the A-wire, thus releasing relays J and K, while KK₅ takes over the function of J₂ to disconnect ZZ and XX relays and the subscribers' common from the B-wire. Contacts KK₂ and KK₁ connect subscriber number ten to the A and B wires respectively. Relay KK is held operated to the B-wire on the 9th step of the switch by the 50-ohm battery on arc 1. At this stage, arc 2 contact 9 is disconnected to prevent the discriminating battery being extended round the subscriber's loop. On the 10th position, the junction wires are connected to the repeating coil bridge, operating relay L *via* relay KK. The 10th contact on arc 5 is arranged to disconnect the circuit of the interacting relays.

The operator rings in the normal manner, but instead of directly operating the subscriber's bell, relay RG responds, and when the above circuit conditions have been satisfied, contact RG₂ extends ringing to the A-wire whilst RG₁ provides a return path on the B-wire. When the subscriber answers, relay LA operates and, as previously described, provides control over supervisory conditions.

It will be seen that relay KK is connected to earth from one wire, and to provide a transmission balance the retard IA and its associated condenser is connected to the other wire.

When the subscriber has completed his conversation and replaces the receiver, he gives a clearing signal to the operator, who withdraws her plug from the multiple. Relays KK and KR release, thus effecting the release of BB, BC, KX and KZ. BB in releasing completes, at BB₃, the homing circuit on the third arc of the sequence switch which drives to contact 22. Meanwhile BB₂ releases relay B which at B₆ (released) arranges for the sequence switch to reach the 25th contact. When LB has released after release of B₄, the switch is stepped to the home contact. Contacts BC₂ and 1 disconnect the A and B wires during homing, since BA is held operated. Relays G and GG, having been released by B₄, remove the engaged test from the multiple.

It will be noticed that the circuit is arranged to preclude the possibility of connecting the line wipers to the home contact until all relays are released in the Parent Exchange relay-set.

The facility of permitting two subscribers on the same satellite exchange to communicate will be described by assuming that subscriber No. 1 is calling subscriber No. 10.

The demand is received by the operator from subscriber No. 1 in the manner previously described for an originating call. She then inserts her calling plug into the multiple jack No. 10 and removes the answering plug from the common answering jack. The latter operation releases relays CO and OC, contact CO₂ releasing relays G and GG. On the release of GG the circuit of KK is completed *via* GG₅ to the sleeve battery. The circuit sequence is now the same as for any ordinary call incoming to subscriber

No. 10. It will perhaps be recalled that the first step of the sequence switch disconnected both the A and B wires of the junction, thus releasing relay AA which was operated when subscriber No. 1 called. Further, arrangements have been made, as described, to keep the subscribers' common disconnected during the selecting and connecting of the required subscriber. Thus, relay AA has so far been prevented from re-operating.

When subscriber No. 10 answers the ringing, the operator inserts an answering plug into the "Intercommunication Jack" which effects the operation of relay IC. Contact IC₂ restarts the interrupter relays and contact W₂ steps the switch steadily to bank contact 14 *via* IC₁. The A and B wires are disconnected when the switch steps to the 11th position, thus releasing relay KK, (Fig. 7) and therefore subscriber No. 10, from the junction. On the 12th contact on arc 1, a high resistance battery is applied

to the B-wire which commences the operation of relays AA and KK *via* the respective subscriber's loop. These relays are fully operated, when the switch steps to the next contact, by the heavy battery from arc 1, and on the switch reaching the 14th position the A and B wires are connected to relays L and LA, the latter providing supervisory control to the cord circuit. Both subscribers are now in parallel on the junction, all other subscribers being disconnected.

In conclusion, it may perhaps be mentioned that the use of twin contacts will greatly reduce the fault liability of all relays. In addition, the satellite relays are housed in dustproof boxes which should be of further protection in this respect. In the event of a fault developing at the satellite, the complete exchange can be jacked out and replaced by another in a few minutes.

Miscellaneous Facilities at Automatic and Manual Telephone Exchanges

TESTING AND OBSERVATION FACILITIES FOR SUBSCRIBERS' METERS.

A. HOGGIN.

IN view of the attitude adopted by the average subscriber towards his telephone account, it is essential that the number of debited calls should be above suspicion. The indisputable accuracy and correct operation of subscribers' meters at automatic exchanges is therefore of supreme importance.

Two types of testing circuit exist for checking the functioning of subscribers' meters. One of these equipments enables engineering officers to make routine tests of meters at regular intervals, whilst the other equipment is used by the traffic staff when testing a particular meter which is suspected of being faulty. Thus, on the comparatively rare occasions when a subscriber disputes his telephone account, there are ample means for testing the operation of the meter concerned.

If the subscriber persists in his complaint of overcharging, however, his line may be associated with meter observation equipment. A "check" meter in this equipment operates in synchronism with the subscriber's meter, so that a continuous watch is maintained on the number of debited calls. (Meter observation equipment will be described in a subsequent article).

Routine Testing Equipment.

A typical routine testing circuit is shown in Fig. 1. On the left-hand side of the Fig. will be seen the details of a portable test box, the connexions to which are terminated on a one-way meter test plug for insertion into the routine test jack of the meter

under test, and a 10-way plug which is placed in jacks fitted at intervals along the meter rack.

The circuit shown is used at exchanges with 4th wire "battery" metering where the subscriber's meter is connected by a contact of the K relay. This relay is therefore operated during tests of the meter, as described below.

The test distributor selector is, of course, normally controlled from the Test Desk. Therefore, if the distributor is in use when the 10-way plug and jack are associated, the engaged lamp on the portable test box is connected *via* contact BQ₁. Although the distributor is free, however, the subscriber's line may be engaged when the meter test plug is inserted, in which case relay M operates to light the engaged lamp. When both the distributor and line are free, the subscriber's number is dialled from the test box. If, during the dialling process, the subscriber's line is taken into use for an outgoing or an incoming call, relay G in the test final selector operates relay PR in the distributor which will, in turn, connect a flashing earth to the engaged lamp. But if the line remains free, relay PC in the test final selector operates the subscriber's K relay to complete the meter circuit at K₅.

"Operate" and "non-operate" conditions are applied to the meter by passing a current through it which is between the specified current and the actual current which it normally receives.

Assuming that the engaged lamp does not flash, the meter test key is thrown to the "operate" position to connect relays C, MD and B. The latter

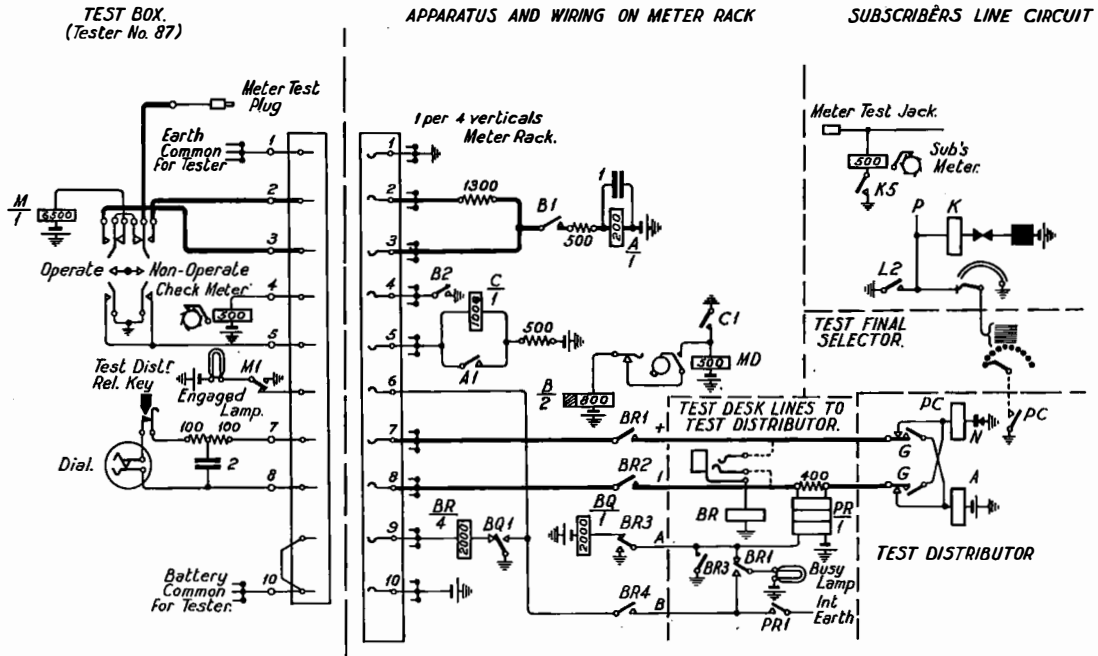

FIG. 1.—ROUTINE TEST CIRCUIT FOR TESTING SUBSCRIBERS' METERS.

relay operates the check meter and connects the meter under test in series with a 500-ohm resistance to relay A. The subscriber's meter therefore operates and contact A1 releases C, which then disconnects MB, B and A. Relay C then re-operates and the cycle is repeated ten times until B is finally disconnected by the auxiliary contacts of MD.

If the subscriber's meter has functioned correctly, the meter test key is thrown to the "non-operate" position and a similar cycle of events takes place, except that, as the subscriber's meter is connected via a 1,300-ohms resistance, it should not respond.

When routine tests are to be made on a number of consecutive meters the foregoing procedure is followed by transferring the meter test plug to the next meter to be tested. Unless the engaged lamp glows to indicate that the subscriber's line is in use, the digit 1 is dialled from the test final selector to the next line.

Special Tests of Meters.

As mentioned above, facilities are provided whereby the Traffic Staff can verify that a particular meter is working correctly. The circuit, shown in Fig. 2, temporarily diverts the line concerned from the normal subscriber's line circuit to a spare calling equipment and meter, so that calls can be originated while tests are in progress. This is achieved by plugs and jacks on the Main Distribution Frame and by means of a key fitted adjacent to, or on, the meter rack. Two telephones are also fitted near this rack.

As the key is normally thrown, the "A" telephone is connected to the subscriber's line circuit under test, whilst the "B" telephone is connected to an ordinary exchange line circuit. The number

of the "B" telephone is dialled from telephone "A" and the operation of the meter is checked when the receiver of telephone "B" is lifted. This procedure is repeated four times.

If it so happens that a call incoming to the subscriber is received on telephone "A" the supervisory lamp fitted near the key, and controlled by relay L, indicates whether or not the subscriber's line is engaged on an outgoing call. Assuming that

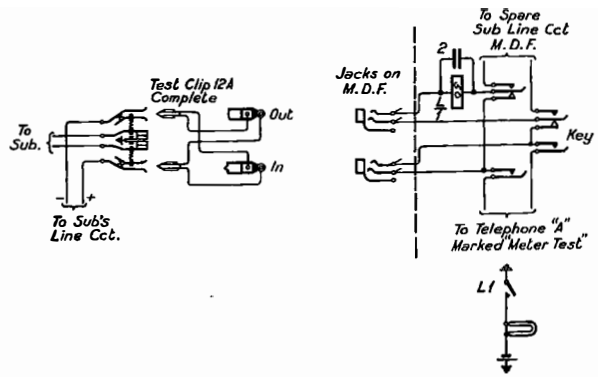

FIG. 2.—SUBSCRIBERS' METER TEST CIRCUIT.

the line is free the key is restored to extend the caller and ring the subscriber's bell. The lamp will immediately glow and continue to do so until the end of the call when further tests can then be undertaken.

Calls originated by the subscriber while his meter is being tested are recorded on the meter of the calling equipment to which he has been diverted temporarily.

The Snow Storm of February, 1933

SPEEDY RESTORATION OF SERVICE

CAPT. J. G. HINES.

THE storm which occurred on February 24th and 25th, 1933, will long be remembered because of its intensity in certain parts of the country. Although the general effect was not so widespread as the great storm of 1916 yet in certain parts of the country, particularly South Wales and Yorkshire, the amount of damage was greater. Owing to the considerable extension of underground cables on main routes which has taken place in recent years there was very little delay to telephone traffic between large towns but minor lines and subscribers' circuits suffered severely. In those parts of the country which suffered most the circumstances were unusual. In sheltered places the snow fell in a half-melted condition, with absence of wind, which enabled the snow to cling to the wires. Within an hour the diameter of the snow on some of the wires reached three inches. This snow subsequently froze into a solid mass. The wind then increased to great force and the resulting pressure caused some spans of wires to break. This threw a heavy unequal strain on the poles which, combined with the wind pressure, caused them to break or be uprooted. In some cases the spans of wire were blown several hundred yards away. It is remarkable that although on high ground the snow was several feet deep and the wind was very strong little damage was done to the Post Office lines. This is attributed to the fact that the snow was dry and did not cling to the wires to any appreciable extent.

Immediate steps were taken to restore service, including the despatch of the necessary stores and the transfer of men from areas least affected. A number of additional men were recruited to assist in the repairs or to replace men withdrawn for the purpose. Much excellent work was done, as is evidenced by the fact that, notwithstanding the blockage of the roads by debris and floods, approximately 60% of the 60,500 subscribers' lines affected were restored within 10 days. The restoration of the remainder quickly followed, but much of the work was necessarily of a temporary character. This is now being followed by the permanent repairs.

Pending the repairs of the wires some outlets for telegraph traffic were provided by radio links between Milford Haven and Burnham and between Fishguard and Swansea. These circuits were worked Wheat-

stone Duplex and were kept in operation until permanent telegraph circuits were available. Over 12,600 messages were disposed of by this means.

Owing to the difficulty of traversing the routes it took some time to ascertain the full extent of the damage and until this was done it was not possible to determine the most satisfactory means of restoring service. Fortunately it was possible in some cases to use spare underground wires. In the case of the route between Carmarthen and Milford Haven it was found that very few poles were left standing throughout the 40 miles and there was no alternative route. As soon as the road was clear an officer from Headquarters made a survey in conjunction with the District Officers and it was seen that if complete restoration of the heavy route were undertaken much delay would occur in providing a satisfactory service. Moreover, owing to the congestion of the open route, the provision of a cable had been under consideration. In the circumstances it was decided not to restore the heavy route but to erect as quickly as possible a 16-wire route which would provide a partial service and be ultimately used for serving intermediate exchanges and subscribers. This route was erected with great expedition and was brought into service over the whole 40 miles on March 27th. At the same time it was decided to proceed as quickly as possible with the provision of an armoured cable containing 38 pairs between Carmarthen and Milford Haven with a spur to Tenby

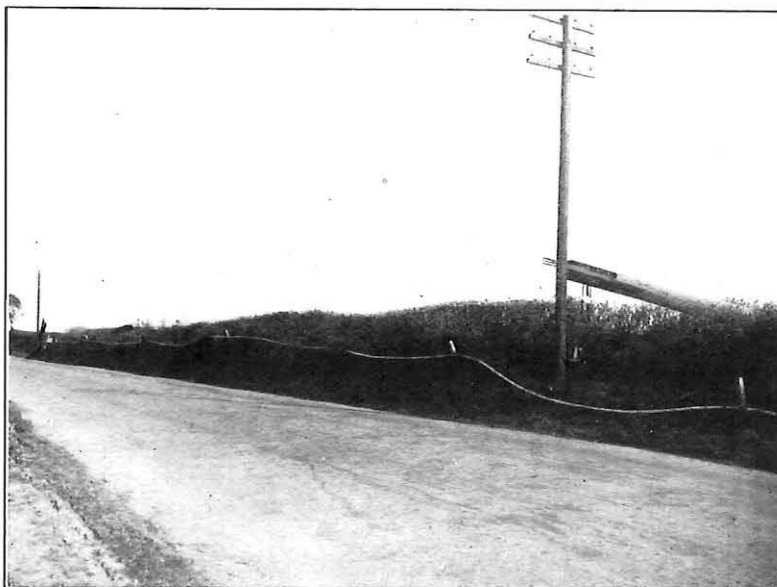

FIG. 1.—CABLE IN POSITION ALONG HEDGE BANK.



FIG. 2.—BURIED LOADING POT.

containing 28 pairs. As a full service could not be given until the cable had been provided it was necessary to adopt unusual measures to secure early completion. It was therefore decided that the cable should be provided at first in a temporary manner, leaving as much as possible of the permanent work to be done after the cable had been brought into use. Where a grass margin existed the cable would be laid upon this; where there was no margin it would be placed in the hedge bank and kept in position by stakes—see Fig. 1, which also shows the light route to which reference has been previously made. When it was necessary to cross roads and gateways the cable would be buried to the usual depth with a creosoted plank placed over the cable before the ground was filled in. Where spare pipes existed through towns these would be utilised. The circuits were to be loaded with 30 mH coils in buried iron pots spaced at 2,000 yards. (Fig. 2).

On March 7th the proposals were placed before the Department's Contractors with a request that the cable and loading coils should be manufactured, laid and jointed within a month. The Contractors were startled, but when they had recovered breath they determined to rise to the occasion and said that if it were humanly possible it should be done.

By the evening of March 10th the first 500-yard length of cable was completed and ready for test and the whole of the cable was manufactured

by March 24th. Equal expedition was shown in the manufacture of the loading coils and pots. The first seven pots were completed by March 17th and the others followed rapidly.

Installation was commenced on March 17th. Two Contractors were employed, viz., Messrs. Standard Telephones & Cables and Messrs. Pirelli General Cable Co. They commenced approximately midway, the former working towards Milford Haven and the latter towards Carmarthen.

A gang of men was sent ahead to open trenches at road crossings. A drum of cable was mounted on a special carrier and drawn by a lorry or tractor (Figs. 3 and 4) which travelled along the road at the rate of about a mile an

hour on the straight sections of route. Men were employed to pay out the cable and lift it into its temporary position and another gang followed to fill in the ground at road crossings and to make the cable safe in its temporary position (Fig. 3). As soon as the ends were available at jointing and loading points the jointing was commenced. The completed joints were protected by cast-iron couplings (Fig. 5).

The whole of the cabling and jointing work was completed by April 9th and was well within the specification for electrical characteristics. This was a remarkable performance and, so far as is known, constitutes a record.

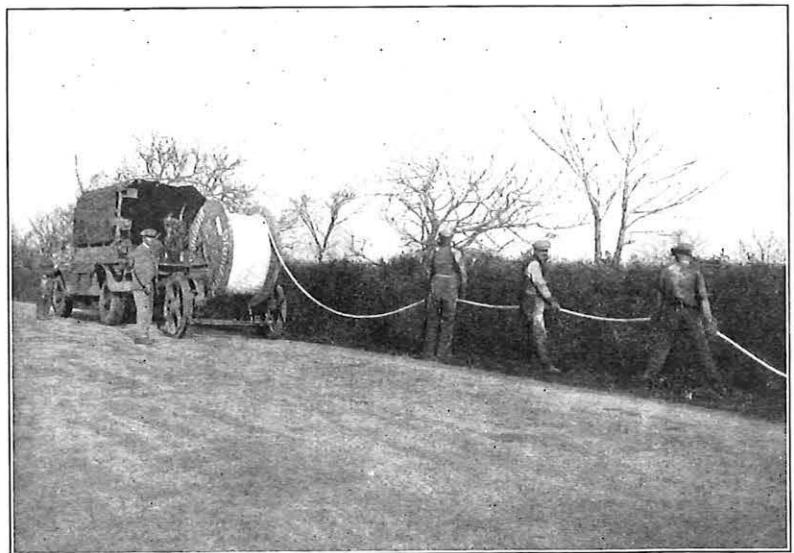

FIG. 3.—PAYING OUT CABLE.



FIG. 4.—LIFTING CABLE INTO POSITION.

The work of burying the cable to the normal depth then followed. Owing to the careful manner in which the cable had been laid out, there was practically no slack to be accommodated.

It will be realised that amplifiers are necessary on a cable of this type and length and that the cable could not be brought into use until these were available. There were no existing repeater stations and it was necessary therefore to equip stations at Carmarthen and Haverford West. This work was carried out by the Post Office staff. The amplifying equipment with the necessary power plant was completed by April 10th.

After a decision had been made to proceed with the cable it was decided to provide some telegraph circuits by voice frequency equipment to be installed at the ends of the cable. Messrs. Standard Telephones & Cables, Ltd., were requested to instal this equipment.

By the time that the cable repeaters were ready a 6-channel V.F. equipment had been installed and on the morning after the completion of the cable this equipment was brought into use, to the great satisfaction of the fish merchants as this was the busiest week of the year for them. The remainder of the telephone circuits were quickly set up and brought into use.

The eleven mile spur to Tenby was also dealt with speedily and was completed on April 21st.

On the whole scheme there are 51 miles of cable, 45 loading pots and 200 joints. The total time taken to complete the work, including amplifiers for all circuits, V.F. channels, power plant, subsidiary equipment and all necessary testing and setting up circuits was less than six weeks. This result was only made possible by the excellent organisation adopted by the Contractors, who left no stone unturned in their efforts to comply with the requirements of the Engineering Department.



FIG. 5.—CAST IRON COUPLING OVER JOINT

A Wire Stringing Tool

A NEW tool has been introduced recently for the purpose of threading open wires in position on pole lines. The tool is used in conjunction with standard pruning rods and avoids the necessity of ascending poles. The essential features of the method were conveyed to the Department by Mr. S. R. Robinson, New Zealand, and the form of the tool has been evolved in the Engineer-in-Chief's Office.

Briefly, the method of use is as follows:—

- (1) The end of the wire to be run is passed through the small hole in the stem of the stringing tool, and the free end is twisted round the running end to prevent it from running back. The tool is secured to the top of the pruning rods by inserting the lower, tapered, end into the square hole in the special adapter (Fig. 1).

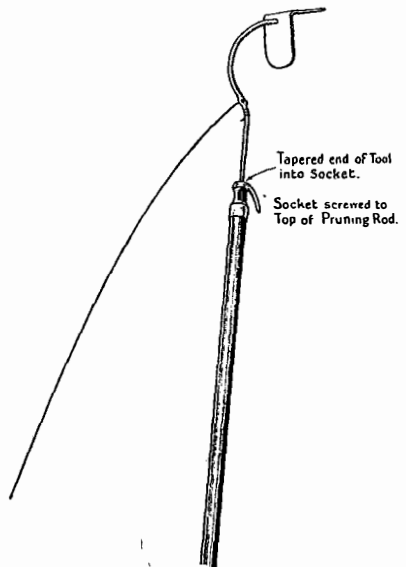

FIG. 1.—WIRE STRINGING TOOL.

- (2) The rods are then raised until the top of the tool is just above the arm which is to carry the wire, and the tool is allowed to rest on the arm.
- (3) By giving a slight downward jerk to the pruning rods, the adapter is detached from the stringing tool which is left in position on the arm (Fig. 2).
- (4) The pruning rods are then taken to the other side of the pole, and the hook of the adapter is dropped into the large hole in the bracket portion of the tool (Fig. 3).
- (5) By giving a slight jerk while walking in the direction of the next pole in the route, the tool is levered over the arm and brings the line wire with it.

By repeating these operations at successive poles in the route, the line wire may be run in its correct position on the arms. The use of two stringing tools and two coils of wire, taking care to avoid

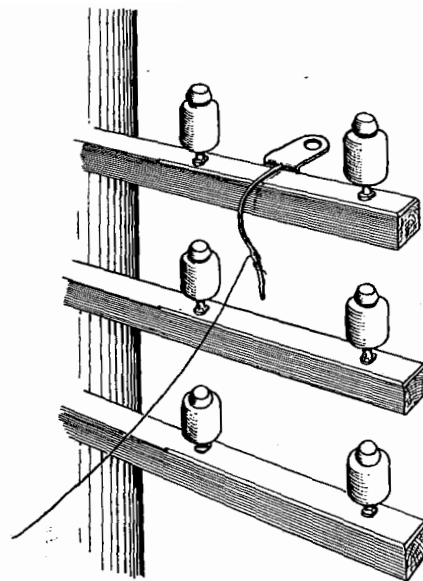

FIG. 2.—TOOL PLACED IN POSITION ON ARM.

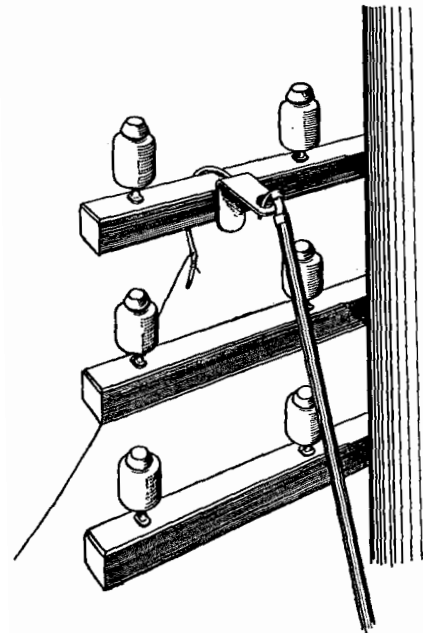

FIG. 3.—TOOL AND LINE WIRE BEING DRAWN OVER THE ARM.

tangling them as each is passed over the arm, makes it possible to run a pair of wires at each pole instead of running first one wire over the required number of spans and then repeating the operations for the second wire.

In this method of running wires, the coil or coils of wire remain at the starting end, the running end of the coil and the stringing tool being carried on from pole to pole.

W.H.B.
J.J.E.

Small Automatically Controlled Power Plants

H. C. JONES, B.Sc., Eng., and H. S. WATERS.

UNTIL recently, it has been the usual practice of the British Post Office to provide power for telephone exchanges by means of duplicate batteries, each of which is charged and discharged in turn and this has proved a thoroughly reliable system. In the case of small exchanges, the practice has been for the maintenance man to attend periodically to change over from the discharged to the charged battery, put the former on charge and set an amperehour meter in series with the charging circuit to an amount equivalent to the required charge. The plant could then be left unattended, the charge being disconnected automatically in due course through the agency of a contact on the amperehour meter. This scheme has proved very satisfactory, but it has the disadvantage that close maintenance attention is necessary to ensure that the discharging battery does not fail on the exchange. When the duration of one discharge lasts over several days it is difficult to judge exactly how long the battery will last and in order to ensure uninterrupted service, the practice is probably to terminate the discharge before the full capacity has been used, and therefore to charge more frequently than is theoretically necessary. Primarily in order to reduce maintenance costs, a scheme which operates automatically to keep a single battery serving the exchange equipment always in practically a fully charged condition, has been developed, and this scheme eliminates the need for the special visits for power plant attention which are necessary with the double battery system.

It is fortunate that the power supplies now becoming available in rural areas where many of these small plants are required, are mainly A.C. as it has enabled the single battery scheme to be based upon a simple and reliable static charging unit which has been found in practice to require a negligible amount of attention, namely, the copper oxide rectifier.

Fig. 1 shows the principle of the scheme in its

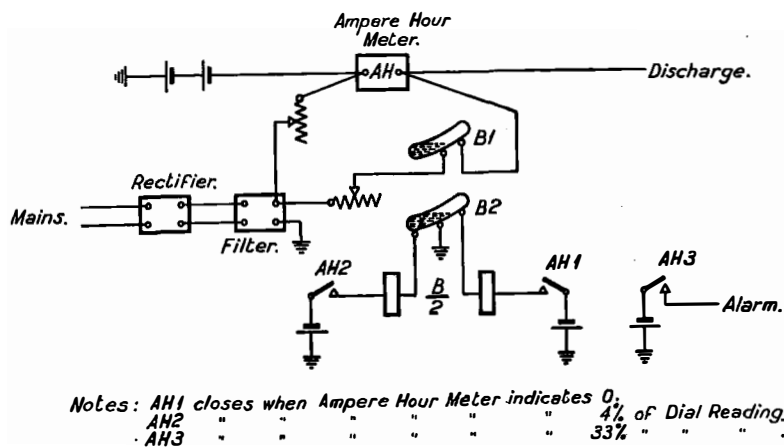

FIG. 1.—PRINCIPLE OF AUTOMATICALLY CONTROLLED POWER PLANT.

simplest form. The essential features are the single battery, the charging unit, an amperehour meter the dial reading of which is approximately equal to the capacity of the battery, through which the battery is charged and discharged. The meter is arranged so that discharge current from the battery to the exchange turns its pointer in a clockwise direction, whilst charging current turns it in the reverse direction. To allow for the efficiency of the battery about 20% more amperehours are required to turn the meter a given distance in the charge than in the discharge direction. The amperehour meter has three contacts, the first, AH1 closes when the pointer indicates zero, the second, AH2, when the pointer indicates 4% of the dial reading, and the third, AH3, when the pointer indicates about 33% of the dial readings.

Assume the battery to be in a thoroughly charged condition, and discharge to commence. The pointer of the amperehour meter will rotate in a clockwise direction and in due course the contact AH2 will cause the relay B, by which the mercury switch B1 will connect the charging current to the battery, to operate. Depending on the value of the discharge current as compared with that from the charging unit, the cells will either still discharge, but at a lesser rate than that before, or receive a charging current. In any case, in due course, they will become charged and the pointer will return to zero. The contact AH1 will then cause the charging unit to be disconnected from the battery, when the cycle of events will be repeated.

A definite though small current is required to start the meter and a current below this value will not operate it. Consequently at times when the charge is disconnected, it would be possible for small discharges, such as insulation losses, to occur without operating the meter. A progressive deterioration of the cells might, therefore, result, and to guard against such an eventuality, a trickle charge is permanently connected to the battery. The value of this current is approximately equal to the minimum operating current of the amperehour meter and is usually about the 1000-hour rate.

In the event of a failure of the power supply, or the charging unit, the battery will tend to discharge to a greater extent than normal, and in order that the continuity of the service may be maintained, arrangements are made for an alarm to be given when the amperehour meter indicates 33% of its dial reading, i.e., when the battery is about a third discharged. As will be seen later, the battery will then still be

capable of maintaining service for about 2½ days, so that there is adequate time to apply remedial measures.

In order to prevent undue noise on the system, the output of the charging unit is fed to the battery through a filter. A series inductance of 2 henries connected to one terminal of the rectifier output with

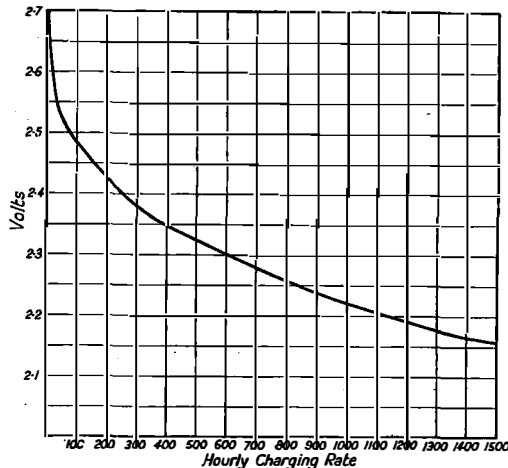

FIG. 2.—TYPICAL CURVE SHOWING VARIATION OF VOLTAGE OF FULLY CHARGED LEAD ACID CELLS WITH CHARGING RATE.

a 250 μF condenser tapped across its centre point and the other terminal of the rectifier has been found to be a satisfactory arrangement.

In the scheme described above, the voltage at the battery terminals varies between wide limits. During discharge, the voltage of each cell drops to slightly less than 2.0, whereas during charge, it rises to possibly 2.5. Such an arrangement is suitable only when a wide voltage variation can be tolerated. The biggest field for this type of equipment is, however, in connection with R. A. X's where a supply within the limits of 46—52 is required. A battery of 24 cells is suitable for these cases, as even at the end of a complete discharge, the peak load is unlikely to be such as to cause the voltage to drop below 1.92 per cell or 46v. for the battery. For the voltage of a 24 cell battery not to exceed 52 on charge, the voltage of each cell must be limited to 2.16. Fig. 2 is a typical curve, showing the variation of voltage when a fully charged cell with planté positives and box type negative plates is charged at

different rates. It will be seen that for the voltage not to exceed 2.16, the charging current must not be greater than the 1440 hour rate. Hence, for the voltage of a 24 cell battery to remain within the stated limits throughout the whole cycle of charge and discharge, its capacity would at least be $\frac{1440}{24} = 60 \times$ the daily discharge. Quite apart from the question as to whether the discharge could be made good at such a low rate, such a large battery is obviously impossible on grounds of cost and space and in order to use cells of a reasonable size, it has been necessary to elaborate the scheme in the manner shown in Fig. 3.

The further development consists of an arrangement by which counter E.M.F. cells are switched into or out of the main battery circuit under the control of a contact voltmeter. When the main battery voltage rises to 52, two counter E.M.F. cells are switched into circuit and reduce the voltage applied to the exchange to approximately 47.5. As charging proceeds, the battery voltage will continue to rise and when it reaches 52 a second time, the operation of the contact voltmeter results in two more counter E.M.F. cells being switched into circuit. While the counter E.M.F. cells are connected, they are charged by the exchange discharge current and their voltage rises to about 2.5 per cell. When the four cells are in circuit, the main battery may, therefore, be allowed to rise to about 62.0 or 2.58 volts per cell without the voltage on the exchange equipment exceeding 52.

Fig. 2 shows that a maximum voltage of 2.58 is attained when the charging current is at the 30 hour

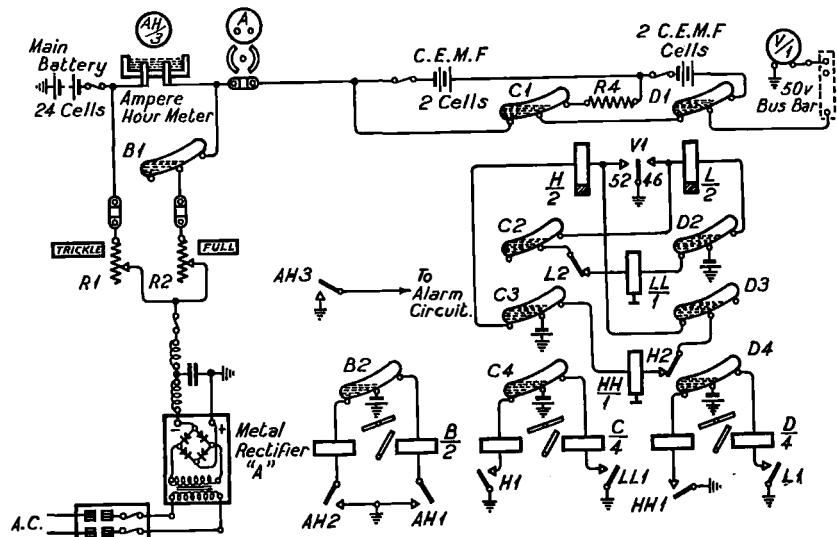

Notes:— AH1 closes when pointer of Ampere Hour indicates "0"
 AH2 closes when pointer indicates 4% of Full dial.
 AH3 is closed when pointer indicates between 33% and 100% of Full dial.
 Relays HH and LL are Dashpot Relays.
 Tubes C1 and D1 are make before break.

FIG. 3.—AUTOMATICALLY CONTROLLED SINGLE-BATTERY POWER PLANT.

rate, and if the output of the charging unit does not exceed this amount, the voltage on the exchange equipment will not exceed 52.

Starting with the amperehour meter indicating zero, the operation of the circuit is as follows:—

The battery will discharge about 4% of its capacity when AH₂ will operate relay B, thus connecting the charging unit to the exchange through the mercury tube B₁. If the discharge is more than the output of the charging unit the battery will continue to discharge, but in any case in due course the discharge current will be exceeded, and the battery will commence to charge. Its voltage will rise and on reaching 52 the top limit voltmeter contact will close, and operate relay H. This relay is of the slow release type, to ensure that as soon as it is operated it will be held sufficiently long to ensure immediate switching in of the first two counter E.M.F. cells and so minimise sparking at the voltmeter contact. H₁ then operates relay C and its four mercury tubes, C₁ switching the first two counter E.M.F. cells into series with the main battery.

It will be seen that the C.E.M.F. cells are short circuited during the change over and the resistance R₄ of about 0.1 ohms is inserted to limit the current. Assuming charging to continue, the voltage may again rise to 52. If so, relay HH will this time be operated as a result of which, relay D will change over its four mercury tubes and by means of D₁ switch two more counter E.M.F. cells into series with the main battery. Charging will then continue until the pointer of the amperehour meter returns to zero, when the closing of AH₁ will cause relay B to cut off the main charge. It should be mentioned that the relative size of the charging unit and the cells is such that the voltage does not again rise to 52 during the completion period of the charge. At the end of the charge, the voltage of the 24 cells in the main battery is of the order of 60. In series and opposition to it are four cells with an overall voltage of about 10 which thus reduce the voltage applied to the exchange to about 50.

After the charging current has been cut off, the voltage applied to the exchange will decrease, and on reaching 46, the bottom limit voltmeter contact will operate relay L. Contact L₁ will cause relay D to change over its four mercury switches and cut out the two counter E.M.F. cells controlled by D₁. The exchange voltage will thus be raised by approximately 5 volts, but will then gradually decrease until it again reaches 46. The contact voltmeter then will operate LL₁ which will result in change over of relay C and its four mercury tubes, C₁ cutting out the remaining two counter E.M.F. cells. The main battery of 24 cells will now be connected direct to the exchange, and its voltage will continue to decrease until it reaches about 48. The discharge current registered after the charging unit is cut off will in due course cause contact AH₂ to close and re-connect the charge, when the sequence of operations will be repeated.

Although facilities are available for switching in

two sets of counter E.M.F. cells, both sets are not necessarily switched in on each cycle of operations. Examination of the circuit will show that the arrangements allow of the first set being switched in and out without the second set. It will be seen that when the first group of C.E.M.F. cells is in circuit alone the current to the exchange is fed through the low resistance R₄. The C.E.M.F. cells can, however, only be cut into and stay in circuit when the main battery is charging, *i.e.*, when the exchange load is less than the output of the charging unit and the voltage drop through the resistance is therefore negligible.

Fig. 4 shows graphically the operation of the equipment when serving a telephone exchange over

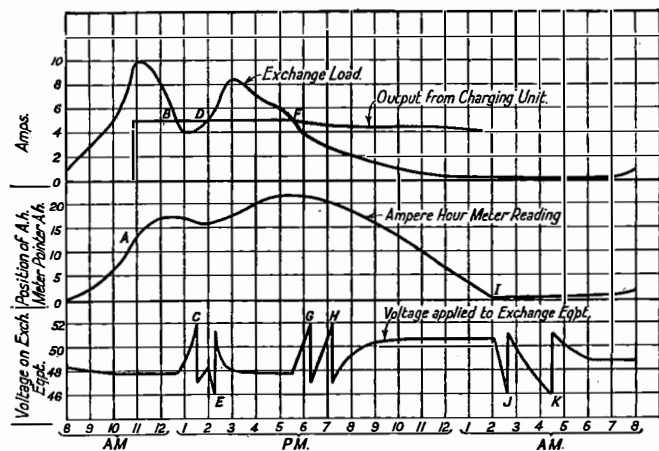

FIG. 4.—CURVES SHOWING TYPICAL DAILY CYCLE OF OPERATIONS OF SINGLE-BATTERY POWER PLANT.

a typical period of 24 hours. The exchange load is assumed to be about 70 ampere-hours a day, the output of the rectifier 5 amps. and the capacity of the battery 300 Ah. The period starts at 8 a.m. when it is assumed the amperehour meter indicates zero. The battery discharges until AH₂ indicates 12 Ah at A when the charge of 5 amps. is connected, thus reducing the rate at which the battery is discharging. At B the exchange load for the first time becomes less than the output of the charging unit. The battery, therefore, receives a charging current and its voltage increases. On reaching 52 at the point C, the first set of two counter E.M.F. cells is cut in, thus reducing the voltage to about 47. The voltage continues to rise, but at D the exchange load which is increasing, again exceeds the output of the charging unit, and discharge current is taken from the main battery, the voltage of which decreases. When the voltage on the exchange reaches 46, the two counter E.M.F. cells are cut out and the exchange voltage is stepped up to about 51. The exchange voltage continues to decrease until it reaches a steady value of about 48. The main battery continues to discharge until several hours later when the exchange load falls below the output

of the charging unit and charging of the battery again commences. The voltage rises to 52.0 at G when the first two counter E.M.F. cells are switched in. As the charging current is increasing in value, the voltage continues to rise and shortly again reaches 52 at H, when it is again reduced by the second set of counter E.M.F. cells. The voltage then continues to rise until it attains a steady value about 50. In due course the amperehour meter will return to zero at I when the output of the charging unit will be disconnected. The exchange voltage will then decrease to 46 at J when the second group of C.E.M.F. cells will be cut out. The voltage will thus be increased by about 5.0 volts, but will then gradually fall until on again reaching 46.0 at K the first group will be cut out. The exchange voltage thus stepped up to about 51.0 will then gradually settle down to about 48.0 until several hours later when the charging unit is reconnected to the circuit.

It was mentioned earlier that if the voltage of the 24 cells comprising the battery did not rise above 62 on charge then the exchange voltage would be unlikely to rise above the limit of 52. Owing to the various factors, such as temperature, variation of specific gravity, possible ageing of the plates and power supply variations which might increase the voltage above the values indicated in Fig. 2, a liberal tolerance of 2 volts is allowed, that is, it is arranged that the rate at the end of the charge is such as will keep the maximum voltage under ordinary circumstances to about 60 or 2.5 volts per cell. It will be seen that the final charging rate must therefore be about the 75 hour rate. The output current of the rectifier, however, decreases as the battery voltage rises and it is found that if the current output is equivalent to the 75 hour rate at 60 volts it is about the 60 hour rate at 48 volts.

These facts may now be used as a basis for deciding the relative sizes of battery and charging unit for a given installation. Assuming the plant is

designed on a basis of 20 hours operation of the charging unit per day at the ultimate period, the remaining 4 hours being allowed as a factor of safety, the exchange load, D, in terms of the ampere-hour capacity of the battery, A, would be approximately

$$D = \frac{7A}{60} + \frac{0.83 \times 13A}{68}$$

$$i.e., \quad A = 3.6D$$

In obtaining the above expression it is assumed that for 7 hours the exchange load exceeds the output of the rectifier, during which time the output of the latter would be at the 60 hour rate. During the remaining 13 hours the battery would be charging at an average of the 68 hour rate. As the ampere-hour meter is 20% slower in the charge than in the discharge direction only 83% of this amount will in due course be supplied to the exchange.

The advantages of the single battery scheme from a point of view of capital expenditure will be appreciated by the fact that whereas an installation requiring 60 Ah per day is usually served by batteries of 72 Ah capacity and a 12 amp. charging unit under double battery conditions, one battery of 40 Ah cells and a charging unit with 0.5 amp. output is all that is necessary for the single battery scheme.

On the maintenance side single battery working is likely to result in appreciably longer battery life. The scheme is also extremely flexible and will automatically meet those occasional abnormal discharges which are difficult to allow for under double battery conditions. Although maintenance attendance will be reduced to an almost negligible amount the fact that an alarm is given in case of a failure of the charging arrangements makes the scheme very safe.

Experience indicates that the circuit arrangements function satisfactorily and there should be a useful future for this type of plant.

The Use of Ballast Resistance in Transmission Bridges

F. B. CHAPMAN, A.M.I.E.E.

IN the present Transmission Bridge used in standard Automatic Exchanges the resistance of the bridge relays is 200 + 200 ohms. This value is a compromise effected to obtain a satisfactory overall result from the following somewhat conflicting requirements:—

- (1) High A.C. impedance—to limit the bridging loss to a small value.
- (2) Low D.C. resistance—to ensure a high sending efficiency of the subscriber's telephone.
- (3) D.C. resistance to be sufficiently high so that fire risk under fault conditions (*i.e.*, full

battery connected across one coil of the relay) is kept to a minimum.

- (4) Reliable operation and suitability for pulsing.

Some years ago, Messrs. Siemens Bros. indicated that by the use of nickel-iron sleeves over the iron core of a relay the impedance can be increased. Investigations have shown that an increase in impedance, of 150% or more, is obtainable and, therefore, a relay of resistance less than 200 + 200 ohms fitted with such sleeves could be produced with an impedance as high as the present

relay without nickel-iron sleeves. It has also been found that satisfactory operation and suitability for impulsing can be obtained with a relay of much lower resistance fitted with nickel-iron sleeves.

It follows, therefore, that as regards the requirements (1), (2), and (4) cited above, a relay of lower resistance is a practical proposition and is of primary importance as regards the sending efficiency of the subscriber's telephone. The reduction in resistance can be of assistance for increasing the sending efficiency of the subscriber's telephone with the present maximum permissible local line resistance or, alternatively, in permitting an increased local line resistance for a given standard of transmission. In the latter case a considerable economy in local line plant may be achieved by the use of lighter gauge conductors.

With the present 200 + 200 ohm bridge relay the current through the subscriber's transmitter on long lines is comparatively small as compared with short lines, and a lower resistance bridge relay would result in heavy currents through the transmitter on short lines. This may not cause damage to the instrument, but the resultant increased side-tone would tend to cause subscribers to lower the voice which may defeat the object of increased sending efficiency.

As regards fire risk (3), however, with the present 200 + 200 ohm relay the loading on one coil when an earth is connected to the battery connected coil (equivalent to a zero resistance earth fault on the negative line) is $12\frac{1}{2}$ watts, a value which can only just be dissipated without serious damage and is not entirely satisfactory for unattended exchanges. Therefore the use of any value less than 200 + 200 ohms is not permissible unless suitable protection is afforded such as the provision of a microfuse.

From the foregoing, two main difficulties arise out of the use of lower resistance bridge relays and these are :

- a. Heating and suitable means for protection.
- b. Regulation of transmitter current as between subscribers' lines of high and low resistance.

These difficulties may be overcome by the use of a resistance in series with the low resistance bridge relay, if the resistance has the characteristic of being very low when the current passing is small and high when the current is large. Such resistances do exist and are known as "Ballast Resistances."

An early form of "Ballast Resistance" consists of a filament of iron wire enclosed in an atmosphere of hydrogen. Generally, such resistances have a somewhat short life, and they are easily damaged if the voltage rises only slightly beyond that for which they are designed. They are usually used to regulate current, passing through them, to a prescribed value within narrow limits of voltage change, and were therefore not found to be entirely suitable for use with the wide range of subscribers' line resistance encountered in practice.

Messrs. Siemens Bros., however, have produced a new type of "Ballast Resistance" consisting of a filament of tungsten wire in an atmosphere of hydrogen. This type of ballast will give long life and withstand all reasonable fault conditions, whilst the resistance current characteristics are more suited to the particular requirements of varying subscribers' line resistances.

Experiments have been conducted upon three single-filament ballasts of the new type for association with 50 + 50 ohm bridge relays. The three types being known as 140 mA, 100 mA, and 90 mA, these values being approximately the current that each allow to pass on a zero line with the 50 + 50 ohm relay.

From a heating point of view, therefore, it is evident that the ballast resistance will serve as ample guard for the low resistance relay, the wattage to be dissipated on one winding of the 50 + 50 ohm relay to a zero resistance earth fault being of the order of 1 watt, which is considerably less than the $12\frac{1}{2}$ watts that obtains with the present 200 + 200 ohm relay—the ballast resistance, of course, being in series with the battery connected coil of the 50 + 50 ohm relay.

With regard to the use, in automatic exchanges, of low resistance bridge relays associated with ballast resistances, it is only necessary to apply them on the side of the transmission bridge which supplies the current for subscribers' transmitters. Thus in a Director area the ballast resistance feed would be applied on the calling subscriber's side of the First Code Selector and the called subscriber's side of the Final Selector. In Non-Director areas the "A" relay of the Final Selector only supplies current for a subscriber's transmitter in the case of a call originated by a subscriber to another on the same main non-director exchange. For this case it is considered that there is no particular need for increased sending efficiency and therefore the "A" relay could remain as the present 200 + 200 ohm type, but ballast resistance feed would be applied to the calling subscriber's side of Discriminating Selector Repeaters and Auto-Auto Relay-sets and the called subscriber's side of Final Selectors. Other circuits, of course, are involved and in general it would only be necessary to ensure that, on junction calls originating from, or incoming to, a subscriber, the current to the subscriber's transmitter is fed *via* a ballast resistance and a low resistance bridge relay.

Curves showing the average current/resistance characteristics of the three types of ballast resistances are given in Fig. 1, whilst Fig. 2 shows the loop currents when associated with a 50 + 50 ohm bridge relay in comparison with the present 200 + 200 ohm relay. Fig. 3 shows the relative feeding current loss deduced from Fig. 2.

From Figs. 2 and 3 it will be seen that in the 140 mA type ballast an increase of feeding current is obtained throughout a range of line resistance and a corresponding reduction in the relative feeding

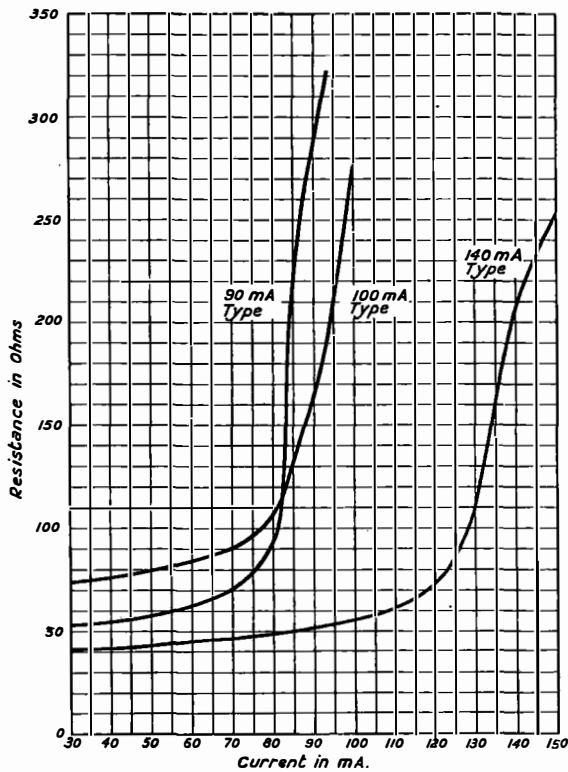
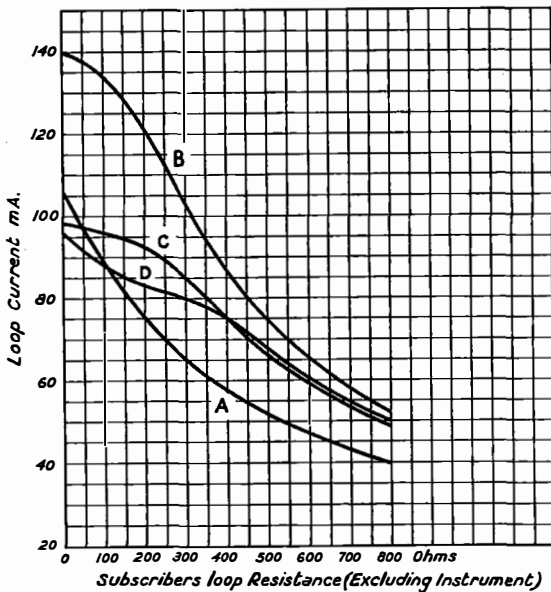
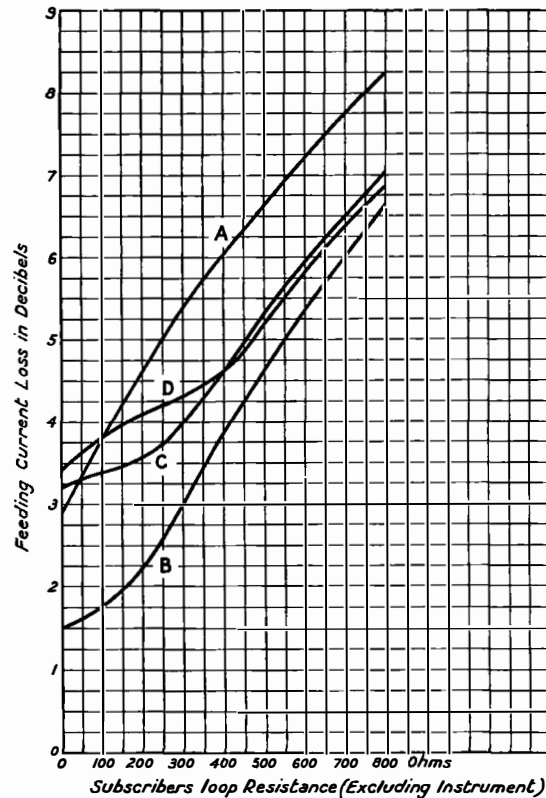

FIG. 1.—AVERAGE CURRENT/RESISTANCE CHARACTERISTICS OF BALLAST RESISTANCES.



Curve A. 200Ω + 200Ω relay without ballast.
 „ B. 50Ω + 50Ω relay with three nickel-iron sleeves and 140 mA type ballast.
 „ C. 50Ω + 50Ω relay with three nickel-iron sleeves and 100 mA type ballast.
 „ D. 50Ω + 50Ω relay with three nickel-iron sleeves and 90 mA type ballast.

FIG. 2.—LOOP CURRENT/RESISTANCE CURVES.



Curve A. 200Ω + 200Ω relay without ballast.
 „ B. 50Ω + 50Ω relay with three nickel-iron sleeves and 140 mA type ballast.
 „ C. 50Ω + 50Ω relay with three nickel-iron sleeves and 100 mA type ballast.
 „ D. 50Ω + 50Ω relay with three nickel-iron sleeves and 90 mA type ballast.

FIG. 3.—FEEDING CURRENT LOSS.

current loss as compared with the 200 + 200 ohm relay. With the 90 and 100 mA types, however, it will be seen that on low resistance lines the current is limited to a value comparable with the existing 200 + 200 ohm relay. As stated previously, it is not desirable to increase the transmitter current on short lines owing to the possible degradation of effective transmission due to side-tone, and therefore the 90 and 100 mA types are considered the most suitable for use—the slight decrease on zero lines probably being an advantage rather than a disadvantage. The 100 mA type shows a relative advantage over the 90 mA type on lines up to 350 ohms.

Another important factor arising from the use of increased feeding current is the additional current consumption that would be taken from the exchange battery and power supply. For the 140 mA type ballast there is an increased feeding current of approximately 40 mA throughout a normal range of line resistances. With the 100 mA type, however, the increase in feeding current is not so large, especially on short lines. Thus assuming, say, 50%

of the lines are between 0 and 100 ohms, 25% between 100 and 200 ohms and 25% between 200 and 600 ohms the average increase per ballast is approximately 8 mA. This value would be slightly less in the case of the 90 mA type ballast. In both the 90 mA and 100 mA cases, the increase in feeding current is relatively small as compared with the 40 mA of the 140 mA type ballast. From all points of view the 100 mA type ballast is the most suitable for use.

Fig. 4 indicates the impedance unbalance obtained when the three types of ballast are used with a 50 + 50 ohm relay fitted with three nickel-iron sleeves. The relay itself was balanced and therefore the impedance unbalance shown in the graphs is due solely to the ballast resistance. This unbalance is considered too high, owing to the cross-talk that would result in practice, but it may be minimized by shunting the ballast resistance by a condenser or even by winding the relay with coils unbalanced to counteract the ballast resistance. The latter method, however, is not considered to be practicable for use with varying line resistances and the fact that the ballast itself varies in resistance with varying current.

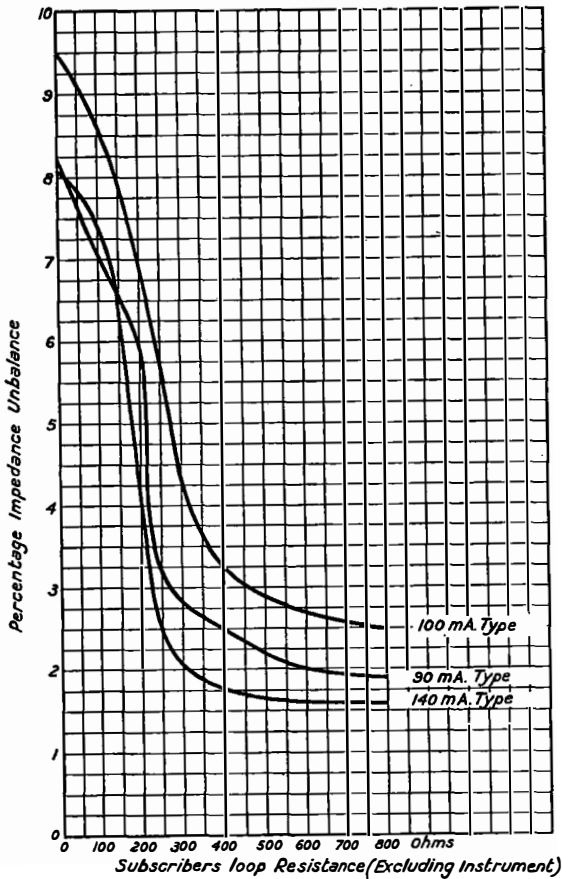

FIG. 4.—IMPEDANCE UNBALANCE OF 50Ω + 50Ω RELAY WITH THREE NICKEL-IRON SLEEVES PLUS SINGLE BALLAST RESISTANCE.

A further method would be to use two ballast resistances (one in series with each coil of the relay) or alternatively use a ballast having twin filaments. Messrs. Siemens have constructed ballast resistances with two separate filaments enclosed in one glass bulb. The characteristics are similar to the 100 mA single filament type referred to in the preceding paragraphs, and the graphs shown in Figs. 1, 2, and 3 can be taken as representative for the twin filament ballast.

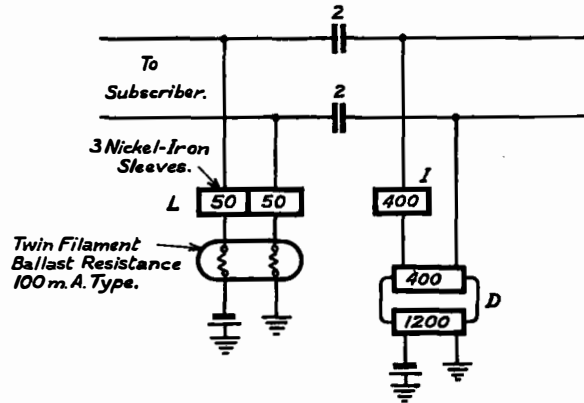

FIG. 5.—FINAL SELECTOR TRANSMISSION BRIDGE EMPLOYING 50Ω + 50Ω RELAY AND BALLAST RESISTANCE.

Tests on the twin filament ballasts have shown that it is possible to produce them without undue unbalance between the individual filaments. Under fault conditions, where one filament may be subject to prolonged heavy current and the other is at rest, the degree of unbalance may increase for a short period after removal of the fault condition. This has not been found to be serious, especially as the balance restores to normal after a period of rest or with normal working currents. The tests have also shown that the life of the ballast can be expected to reach about 30 years if there is no excessive vibration.

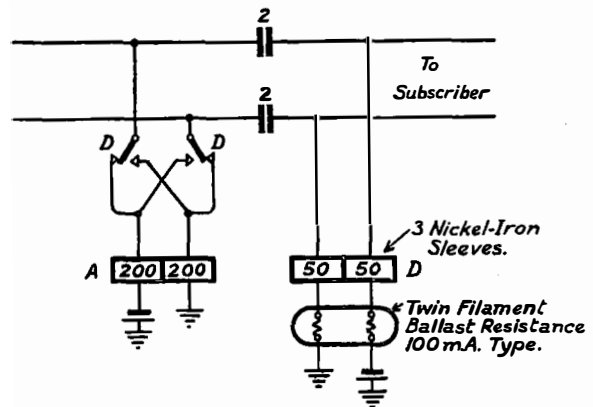

FIG. 6.—FIRST CODE SELECTOR TRANSMISSION BRIDGE EMPLOYING 50Ω + 50Ω RELAY AND BALLAST RESISTANCE.

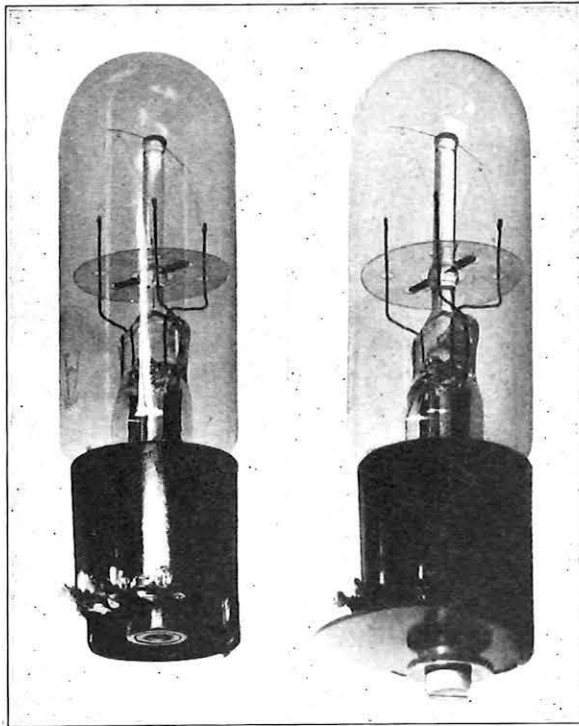

FIG. 7.—100 MA TWIN FILAMENT BALLAST RESISTANCE, SHOWING CONNECTING TAGS, INSULATING WASHER, AND FIXING SCREW.

The twin filament ballast resistances are being subject to an experimental trial under practical working conditions at Springfield Exchange in the Birmingham Area and are associated with $50 + 50$ ohm relays, fitted with nickel-iron sleeves, on the calling side of First Code Selectors and the called side of Final Selectors. The trial has been proceeding for six months or so and the evidence obtained so far indicates that satisfactory performance under working conditions is to be expected.

Figs. 5 and 6 show, schematically, the transmission bridge circuits of Final and First Code-Selectors with twin filament ballast resistances associated with $50 + 50$ ohm relay with nickel-iron sleeves. The "A" relay of the Final Selector is shown as the present $200 + 200$ ohm type of relay as this relay only supplies the feeding current for the calling subscriber in the case of a local call on a Main Non-Director exchange. In this case, as previously stated, it is considered that there is no particular need for increased sending efficiency.

The photograph given in Fig. 7 shows the latest development of Messrs. Siemens 100 mA twin-filament ballast resistance, whilst Fig. 8 is a photograph of a Final selector fitted with a ballast. From Fig. 7 it will be seen that the ballast resistance is arranged for single screw fixing and provided with tags for soldered connexions rather than using a

plug and socket method of mounting. The dimensions are approximately 3" long and 1" diameter. Thus the ballast may be mounted in a relay space on the mounting plate, with connexions made by normal switch plate wiring, or in any other convenient position such as the condenser box at the back of a mounting plate.

In view of the foregoing it will be seen that the use of Ballast Resistances in association with low resistance transmission bridge relays may have a very important effect on Telephone service as a whole on account of the possibilities of improving the general standard of transmission or reducing the cost of local and junction line plant or, alternatively, an arbitrary combination of both.

In conclusion, the author desires to express his thanks to Messrs. Siemens Bros. for the loan of literature and photographs, and acknowledges the use of information obtained from tests carried out at the P.●. Research Station.

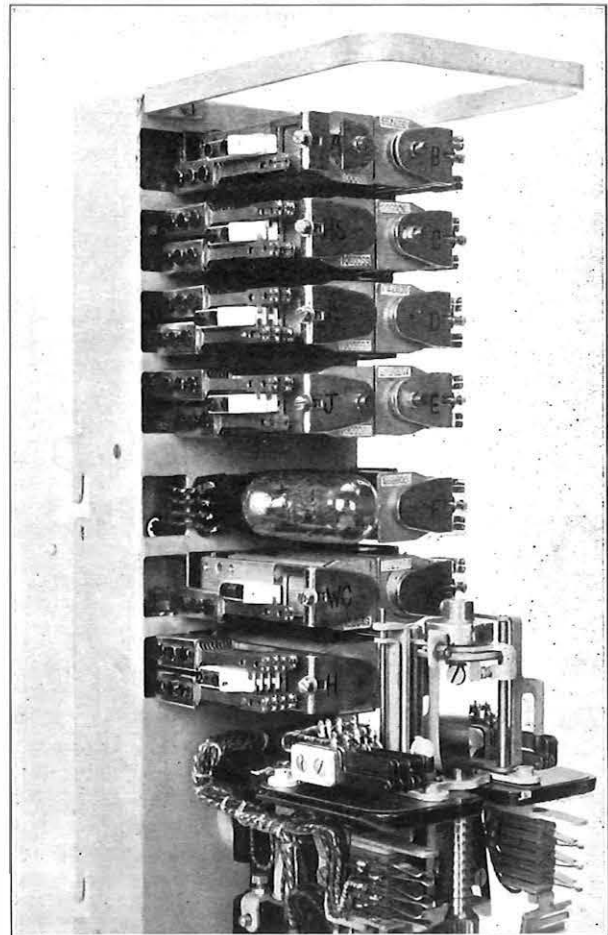

FIG. 8.—FINAL SELECTOR FITTED WITH BALLAST RESISTANCE.

Wigan Exchange

A. G. LYDDALL.

THE opening of the Wigan (Lancs.) automatic exchange on Saturday, March 11th, 1933, instanced a further example of the Department's progressive policy of applying to practice on an experimental basis developments in automatic telephone switching methods. The system is Strowger step-by-step designed and installed by Messrs. Automatic Electric Co., the system being known as Type 30C. The difference from the orthodox type lies in the use of the Common Control principle in certain of the switching stages.¹

The exchange opened with 1,384 subscribers' lines and a multiple capacity of 2,300. These figures include two hypothetical exchanges, Hindley and Platt Bridge, which form the nucleus of two future satellite exchanges, the subscribers being accommodated on the Wigan switching plant, but having a range of numbers proper to the future satellite exchanges.

variations in the holding times of 1st selectors, there is no reason to suppose that increased efficiency over an individually-controlled selector would result from the application of common control. Hence, the 1st selector remains virtually standard practice.

Similar consideration applies to the selector containing the transmission bridge and ringing relays, etc., but in distinction to standard practice, a general principle has been established by the Automatic Electric Company in regard to the provision of common control to the ranks of selectors subsequent to the 1st, that it is preferable to transfer the transmission bridge, etc., from the final selector to one of the preceding ranks of selectors, not common controlled. Therefore, the local 2nd selectors at Wigan contain the transmission bridge and are individually controlled, but level 8 and 9 second selectors, viz., dialling out and manual board services respectively are common controlled, the transmission

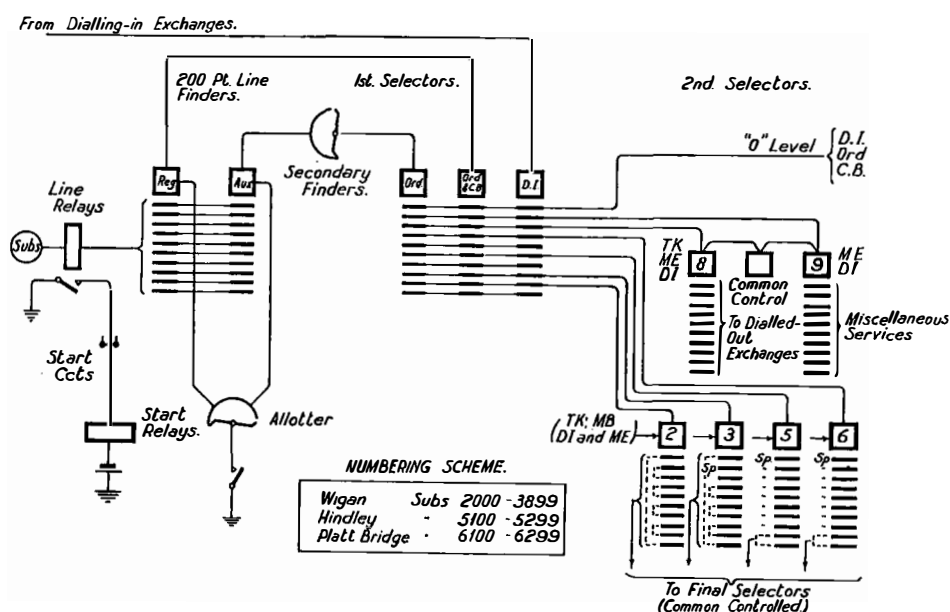

FIG. 1.—TRUNKING DIAGRAM.

Provision is also made for dialling-out facilities to seven manual exchanges within the unit fee area.

The trunking scheme and the ranks at which common control is applied are shown in Fig. 1. The object of the common control principle is to effect economy in switching plant, but investigation has shown that on account of the comparatively wide

feed for calls *via* these selectors being in the outgoing relay-set.

The final selectors, both ordinary and 2/10 P.B.X. types, are also common controlled.

Circuit descriptions and diagrams of the common controlled second and final selectors are included later in the article (Figs. 6 and 7). Battery testing for free outlets is used throughout the scheme. This principle prevents a selector switching on a disconnected outlet, as is possible on "earth" testing schemes, and as an engaged outlet is "busied" with a low resistance earth the possibility of dual connexions is claimed to be virtually non-existent.

The common control selectors and relay-sets are

¹ "Common Control System." R. Taylor and C. E. Beale. *P.O.E.E. Journal*, Vol. 24, page 125.

"Line Finder Developments in the British Telephone System, using 2-motion Selectors." W. A. Phillips, A.M.I.E.E., and R. Taylor. *P.O.E.E. Journal*, Vol. 24, page 276.

mounted on racks 10' 6" high. All selectors are of the 10-level, 20-contact type, and each rack has a capacity for 70 selectors, or 60 selectors and 10 relay-sets. The wiring commons between the relay-sets and the associated selectors are permanent and arranged such that each relay-set controls the selectors mounted in the corresponding position on each shelf, namely, relay-set No. 1 is associated with selectors in No. 1 position on all shelves associated with the same group of controls, No. 2 relay-set with No. 2 position selectors, etc.

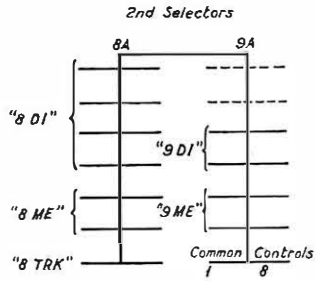

FIG. 2.—LAY-OUT OF COMMON CONTROLLED SECOND SELECTORS.

Fig. 2 depicts the lay-out of the common-controlled second selectors and indicates that five groups of selectors are served from the same set of control relay-sets. Fig. 3 (left) is a photograph of the same apparatus. The maximum ratio of selectors to



FIG. 3.—SECOND SELECTOR RACK, SHOWING CONTROL RELAY-SETS.

relay-sets in this case is 13 to 1, and in the case of final selectors is 9 to 1. The actual ratio in use at present is as follows:—

Second selectors (Levels 8 and 9).	Control Sets.	Approx. ratio.
Level 8 D.I. group	24	} Total 65 8 8 : 1
" 8 M.E. "	16	
" 8 Trk. "	5	
" 9 D.I. "	10	
" 9 M.E. "	10	
Final Selectors.		
Regular and 2/10 P.B.X.	215 28	8 : 1

The difference between the maximum ratios of these two ranks of selectors is accounted for by the lower holding time of 2.0 seconds of the common controls for the second selectors as against 3.5 to 4.0 seconds of the final selector common controls. The reason for this is that the final selector accepts two digits.

It will be appreciated that during the time that a common control set is in use, an artificial busying effect is imposed on the remaining idle selectors in the same "control" group, and though this busy period per call is very small, i.e., the holding time period for the rank of common control under consideration, nevertheless this factor must be included for switch provision design purposes. The net result is that generally a slight increase in selectors is necessary to offset this effect.

In the case of selectors only, this increase is not serious to the economics of common control, but where the selector terminates an incoming junction, the artificial busying effect is circulated over the junctions and selectors, with a consequent increase to both. The increased cost of line plant in such circumstances therefore prohibits the use of common control; hence, the incoming dialling-in junctions at Wigan are individually controlled.

Fig. 4 is a photo of a suite of 200-point line finder racks at Wigan; 16 Finders (7 Regular and 9 Auxiliary) are fitted per 200 subscribers' group, and each rack comprises two such groups with the associated line and cut-off relays, and two primary control sets.

The secondary finders are arranged in two groups of 15 uniselectors per group; hence a common pool of $2 \times 15 = 30$ first selectors is available to all 200-point line finder groups.

The total number of first selectors available for regular subscribers is:—

Per 200 subscribers group	= 7	} = 70
No. of groups	= 10	
Per secondary finders	= 30	= 30
Total		109

In addition 15 first selectors are provided for Coin Box lines served directly from one group of 200-point finders.

Two further non-standard features are also worthy of mention, viz., the Trunk train, and Assisted Service. The facilities afforded by these features were described in the article on Advance exchange



FIG. 4.—SUITE OF 200-POINT LINE FINDER RACKS.

in the previous issue of the Journal. In the Trunk train, the trunk traffic is dialled from Manchester to ordinary 1st selectors with separate outlets to special "transmission feed" 2nd selectors which embody trunk offering facilities. The banks of these are included in the common grading to the regular final selectors. The provision of trunk offering final selectors is thus obviated. The Assisted Service facility is incorporated in the level 91 (Enquiry) relay-sets.

The auto-manual switchboard provides for the latest practice in operating and consists of ten A-, four jack-ended B-, and four Monitors' positions, equipped with sleeve control cord circuits, visual

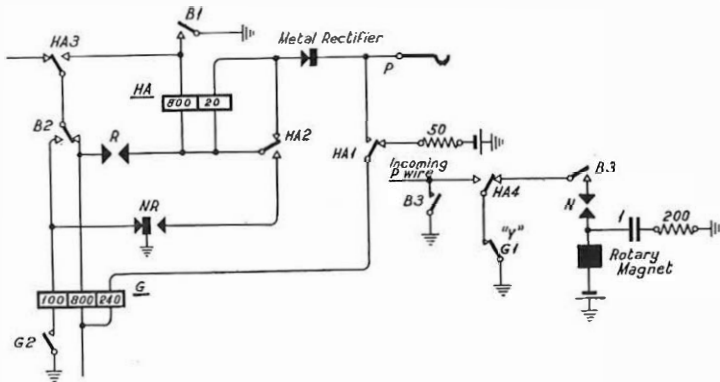

FIG. 5.—OUTLET TESTING CIRCUIT.

idle signals on the O.G.J. multiple, and chargeable time indicators.

Conclusion.

From the foregoing description, it can be seen that the application of the Common Control principle is governed by the all important costs factor, and the principle is applied at any rank of selectors only when it is economical. Similar consideration applies to the 200-point line finder which can, in general, be considered counterpart to the Common Control principle.

It must not be thought, however, that costs are the primary considerations, however much economics in capital expenditure and maintenance costs are desirable. These must be subordinate to the provision of an efficient service, but as the design of the 30C System is based upon the use of the well-known Strowger two-motion selector and relay, it is fully expected that the quality of service given at Wigan will be equal to that given by the standard Strowger system.

The author desires to express grateful thanks to Messrs. Automatic Electric Co. for the use of photographs and subject information, and to Mr. J. H. Russel, of the Engineer-in-Chief's Office, for assistance in preparing the circuit descriptions which follow.

FIRST SELECTOR.

A brief description of the individually controlled first selector is included for the purpose of completing the chain of connecting circuits. The outlet testing circuit is shown in Fig. 5.

When the selector A relay operates from the subscriber's loop, earth is applied on the P-wire to hold the line finder and subscriber's line and cut-off relays. The selector steps vertically and then rotates to find a second selector. Testing for a free battery connected outlet is carried out by the interaction of HA and G relays. If the outlet is engaged or disconnected, relay G operates from earth, B1 oper., HA winding of 800Ω, R springs oper., 800Ω and 240Ω windings of G, HA1 normal, 50Ω res. to battery. The rotary magnet is disconnected at G1, and when R springs open, relay G releases, and again completes the rotary magnet circuit. The selector then takes one step.

If the outlet is free, relay HA will operate via earth, B1 oper., 800Ω winding of HA, HA2 normal, metal rectifier, P-wire to 100Ω resistance battery at the second selector.

Relay HA switches the positive and negative wires through and holds via earth, NR springs operated, HA2 oper., 20Ω winding of HA, metal rectifier to battery at the forward selector. Earth, via the low winding of 20Ω, provides a guarding condition for the outlet. Earth via G1 normal, HA3 oper. and the incoming private wire holds the preceding circuits, when B3 releases.

COMMON-CONTROLLED 2ND NUMERICAL SELECTOR (Fig. 6).

The selector tests free when a low resistance battery, common to a group of selectors, is connected to the P-wire. The H relay of the previous selector operates to this battery, extends the conversational wires through, and applies a low resistance earth to the P-wire. This earth appears, via the common point, on the P-wire of all disengaged selectors forming the group, and thus, while the control relay-set is in use in the setting-up of a call, these selectors are artificially busy to traffic incoming to the rank of selectors.

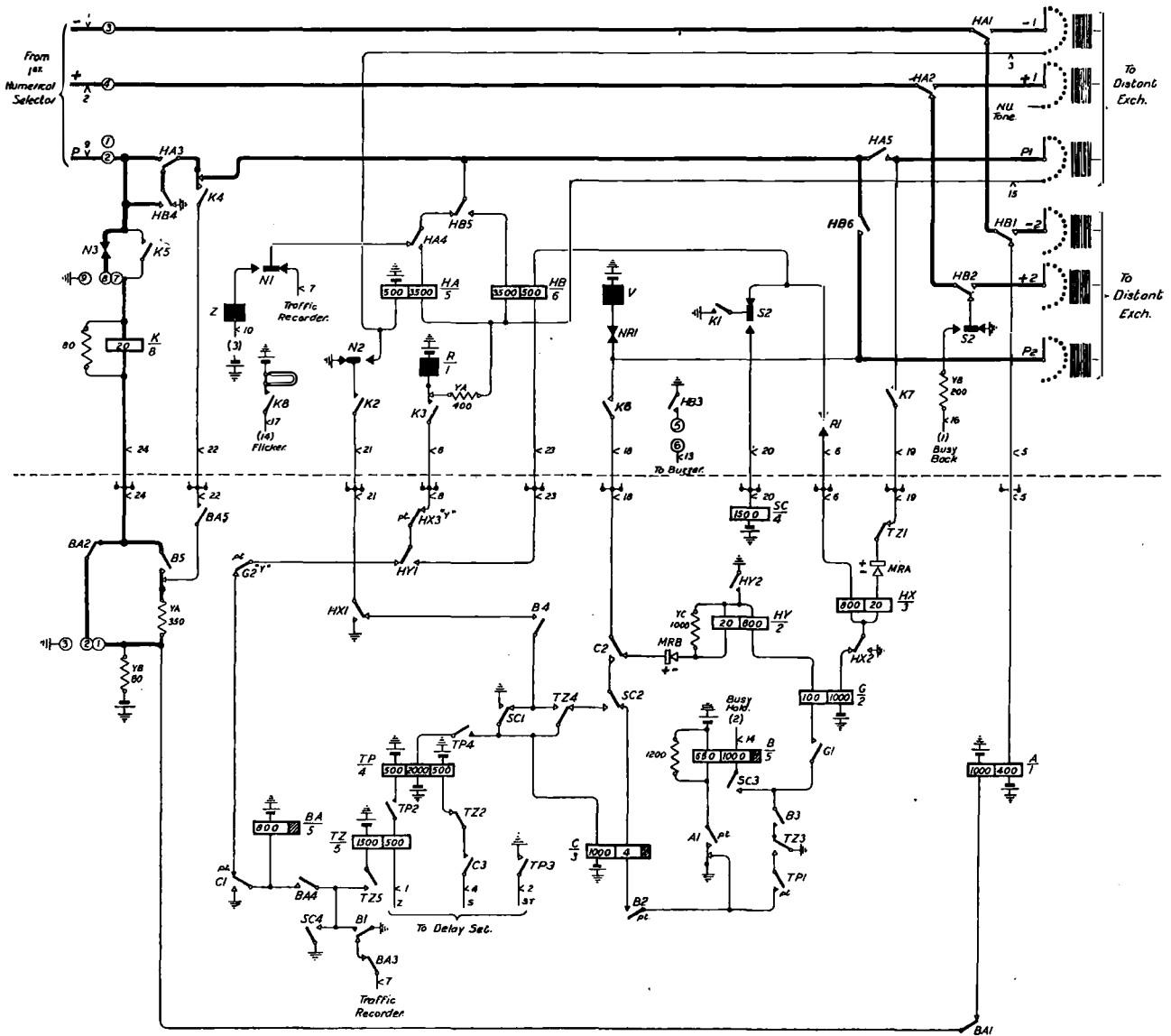

FIG. 6.—COMMON CONTROLLED 2ND NUMERICAL SELECTOR.

The A relay operates to the loop on the conversational wires. K relay operates to the earth extended on the P-wire and connects the selector to the control relay-set. Relay B is operated by A, and together with K operates C, which operates BA.

Relay A is pulsed by the next digit dialled and repeats the impulses via C relay to the vertical magnet, and the selector steps to the required level.

Relay C releases on completion of the digit, and completes the circuit for operation of the rotary magnet. The rotary magnet steps the wipers on to the first contact of the level, and completes the testing circuit for HX and G. If this outlet is busy, i.e., connected to earth, current will flow through both coils of HX from one coil of G. HX does not operate as the current flows in such a direction that the coils are in opposition; G however, does operate and completes the testing circuit for HY. Relay G disconnects the rotary magnet, which breaks the operating circuit for G. If the P₂ outlet is busy, G will be short-circuited by the earth on the P-wire and

will release, re-connecting the rotary magnet and stepping the switch to the next outlet.

If P₂ outlet is free, HY will operate from the earth via G, with current in both coils of HY to the low-resistance battery on the free outlet. The current is in such a direction that, under this condition, the coils of HY now assist one another. Meanwhile the current operating HY holds G.

When HY operates, an earth is connected to the P-wire via the low resistance coil of HY, holding this relay, but short-circuiting G, which releases HY, disconnects the driving circuit of the rotary magnet, and operates HB on its low resistance coil from battery via the rotary magnet.

Relay HB extends the positive, negative and private wires to the next selector and prepares a holding circuit for itself to the P-wire.

The operation of HB releases A, followed by B, which releases K.

Relay K, in releasing, completes the holding circuit of HB on its high resistance coil connected to the P-wire, to the

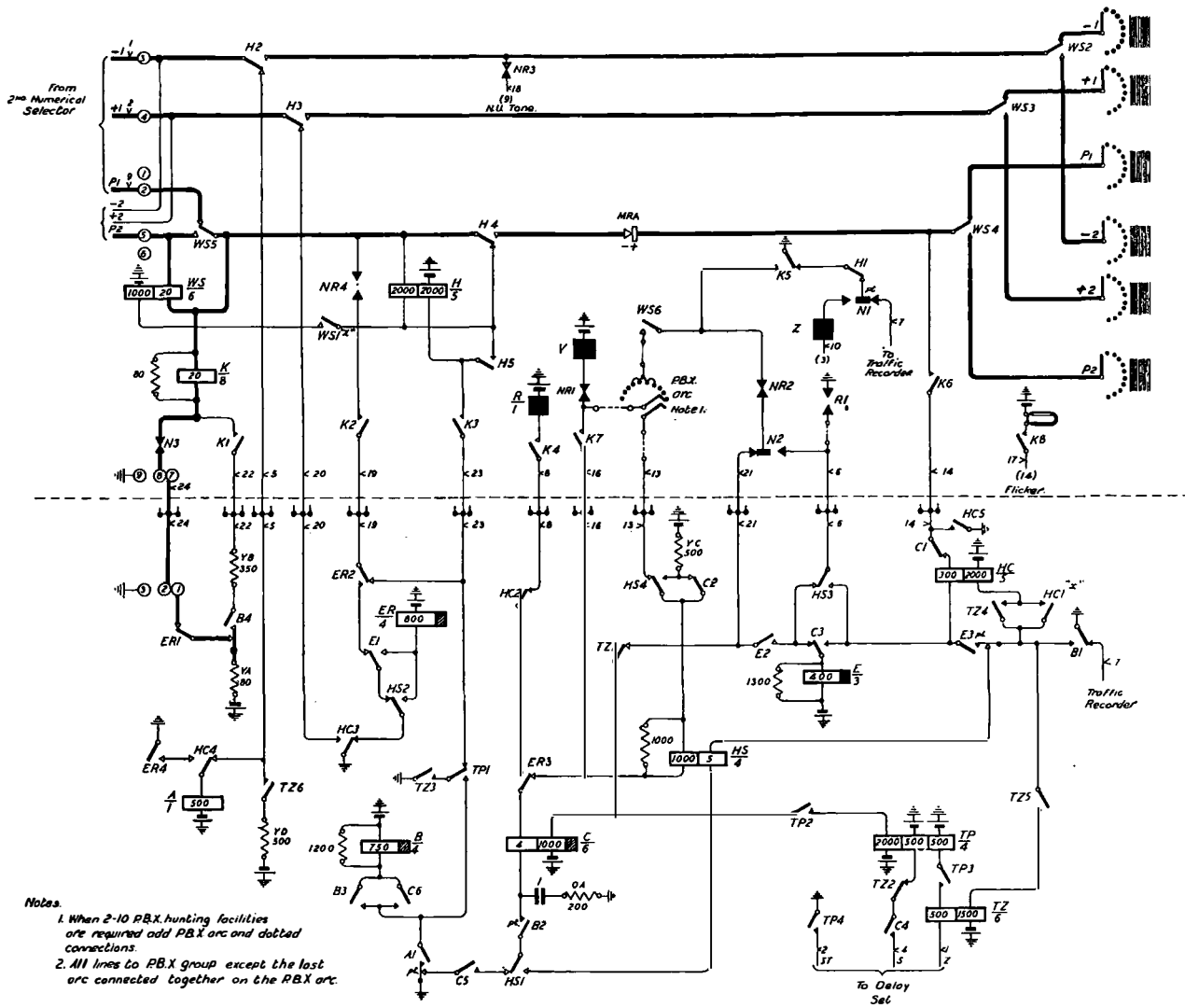

FIG. 7.—COMMON CONTROLLED 200-LINE FINAL SELECTOR.

battery via the rotary magnet, the holding earth on the P-wire now being received from the selector ahead; K also disconnects and releases the control relay-set and allows the other disengaged selectors in the group associated with the control relay-set to become free.

Outlets busy.

Should all outlets be busy the selector steps to the 11th step and operates the cam springs which operate SC in the control set. Busy tone is sent back to the subscriber. Should the subscriber delay in clearing, the control set is released from the selector by the time pulse and N.U. tone is connected to the subscriber.

Incomplete dialling.

If the selector is seized, and no dialling impulses received, the time pulse causes the wipers to rise and cut in to the first level, stepping to the 11th step, returning N.U. tone, and releasing the control relay-set.

COMMON-CONTROLLED 200-LINE FINAL SELECTOR. (Fig. 7).

Discrimination between the two groups of 100 subscribers to which the selector has access is effected in the penultimate stage. The negative, positive and private wires are switched through from this stage when a free final selector has been

found, as indicated by a low-resistance battery on the P-wire from the control set. This battery is common to other selectors, and when one selector is seized the remaining disengaged selectors associated with the particular control set considered are made artificially busy so long as the control set is in use. On seizure, relays A and K operate, followed by C and B.

Relay A responds to the tens digit impulses and repeats them to the vertical magnet. At the completion of the digit dialled, C releases, operating E, which then re-operates C on its high resistance winding. E also operates ER.

Relay A now repeats the units digit impulses to the rotary magnet. At the end of the digit C releases, which releases E slowly. C connects HC to the P-wire of the called subscriber. If the subscriber is disengaged HC operates. This occurs during the slow release of E.

Relay HC releases ER and applies an earth to the positive line to indicate to the penultimate selector that the subscriber is free and may be rung. Relay HC disconnects A from the negative line, but provides a holding circuit during the release of ER. When ER releases, H is operated and A is released. The outgoing P-wire is guarded by HC pending the operation of H.

Relay A releases B, which releases K and the control set

relays; K disconnects the control relay-set from the final selector and allows the remaining disengaged final selectors associated with the control relay-set to become free.

Subscriber engaged.

Should the called subscriber be engaged, an earth will be present on the outgoing P-wire, and HC will not operate. When E releases, an earth will be applied to the incoming P-wire to signal the penultimate selector that the subscriber is engaged. Busy tone is returned from the penultimate selector and the final selector with its control set released by the removal of the holding earth on the P-wire.

Incomplete dialling.

In the event of non-receipt of either the tens or units digits,

the time pulse will step the selector shaft vertically off normal, and return the "subscriber free" signal to the penultimate selector. The resulting ringing is immediately tripped, and when TP, which is held by the Z pulse, releases at the cessation of the pulse, H is operated, returning NU tone to the subscriber, and the control relay-set is released.

P.B.X. working.

The control relay-set shown may be used without alteration with 200-line final selectors having ordinary facilities or with final selectors having 2-10 line P.B.X. facilities in one group of 100 lines and ordinary facilities in the other group of 100 lines. The conversion from an ordinary to a P.B.X. final necessitates the addition of a P.B.X. arc to the selector and the utilization of the WS contact shown spare.

Research

IN the following notes, brief details are given of some of the work that has been in progress during the past few months.

Repeater Systems. Extensive trials on the simplified form of echo suppressor (valveless) have shown that the design should prove very satisfactory and especially so in view of the application of the new two frequency signalling scheme.

A receiving device for 500/20 cycles signalling on trunk lines pending the general introduction of the above two frequency system has been working in a satisfactory manner on a trunk circuit. Additional models have been made and are being applied for test purposes. Difficulties associated with the existing valve signalling receivers whereby false operation arises due to "Telex" can be successfully overcome by the inclusion of a new form of discriminating device involving a metal rectifier.

Carriers. Tests on the equipment manufactured for the Anglo-Dutch cable route have been completed and the installations at Aldeburgh and Domburg are now being introduced into the system to provide the carrier channels.

The experimental mains carrier sets have again been brought into commission to cater for "seasonal" working between Inverness and Kyle, while an additional set is being made available for Scarborough-York. Using this type of equipment the carrier tests in Army D.8 cable at Aldershot have been continued and it has been verified that for 15 or 20 miles the earthed phantom circuit is much better than the side circuit and permits of very good speech being obtained on the carrier.

In connexion with the schemes for combined audio and carrier working on underground repeater circuits, tests have been made on the Carmarthen-Milford Haven route where it is intended to have experimental circuits.

The attenuation and cross-talk results at carrier frequencies indicate that all of the quads should permit of good carrier working on the four wire within quad basis.

Noise in Switchroom. As a result of tests made before and after the treatment of the ceiling of a

switchroom at G.P.O. South with "Parfelt" it was found that the average noise level had been reduced by about 10 db.

Magnetic Flux Test for Receivers. An adaptation of the Crompton "Tong Test" ammeter has been made by which the flux from a receiver magnet may be read directly on a scale. The instrument consists essentially of a moving iron ammeter without a magnet system. By means of suitable pole pieces the flux from a magnet may be led to the movement and made to deflect the pointer. A simple method of calibration was devised.

With modern cobalt steel magnets it is found that the strength of the magnet often gives little or no indication of the transmission efficiency of the receiver, as this latter is more affected by other factors. The test is valuable, however, to check the quality of the magnet.

Local Line Transmission. In connexion with the standardisation of transmission in local areas it has been necessary to prepare curves of local line losses for the Telephone 162, etc., on various types of exchanges both C.B. and L.B. These are nearly complete.

New Type Watch Receivers. Tests have been made of receivers of the same pattern as those on Telephones No. 164 as watch receivers for use in parallel with the existing subscriber's receiver. On the whole the results are better than with the present pattern of extra receiver.

It should be noted, however, that as shown in the curves in the report, in noisy situations greater gain in reception may be obtained by the use of an anti-side tone induction coil with one receiver than by fitting an extra receiver. The loss which occurs when the extra receiver is not in use is eliminated.

Use of Palladium for impulsing relay contacts. The life of Palladium contacts is about half that of Platinum when tested under the same conditions, but as the cost per unit volume is about one quarter that of Platinum, it is considered that a practical trial of Palladium impulsing contacts for group and final selectors is justified.

Alloys of Platinum—10% Rhodium and Palladium

—5% Rhodium-Ruthenium are not suitable for this purpose.

V.F. Supervisory Signal Equipment for Telex Service. This is a supervisory lamp signal for Telex positions to operate on cessation of Telex signals. A relay set incorporating a valve operated relay has been made up and installed at the London Trunk Exchange for a trial on a London-Dover circuit.

Auxiliary Apparatus Unit for Printergram positions. The Telegraph Section required an apparatus unit which will enable Telex subscribers to transmit messages to the Printergram positions at the C.T.O. without requiring the attention of an operator unless the subscriber calls in the operator by pressing his "J" bell key.

The following facilities have been provided by this unit:—

1. The subscriber establishes a telephone call to Printergrams, listens for ringing tone and then a special tone. The cessation of the latter tone indicates that the Printergram Telex apparatus is ready to receive his message.
2. At the end of the message, the subscriber depresses his "J" bell key to call in the operator for an acknowledgement of receipt of the message, thus maintaining existing procedure on phonogram circuits.
3. The circuit is cleared by the depression of a key.

Apparatus which provides these facilities has been constructed and consists of equipment for one position and common equipment suitable for the 18 Printergram positions at the C.T.O. where a trial is to be made.

Liverpool-Douglas Teleprinter Circuits 4 and 5. Two additional teleprinter circuits are being provided between Liverpool and Douglas, I.O.M. (No. 4 and No. 5).

Each circuit is intended to be worked two loop simplex with 40-volt universal batteries between Liverpool and Blackpool, each loop being superposed on telephone pairs. At Blackpool, a telegraph repeater is installed, together with other apparatus, and the section Blackpool-Douglas is worked loop duplex and composited on phantom circuits in the submarine cable between Blackpool and Port Erin, being extended from Port Erin to Douglas by superposition on telephone loops. At Blackpool and Port Erin special electrical filter equipment is installed on the circuit, the line current being provided from special rectifiers drawing power from the A.C. mains at Douglas. 80-volt positive and negative local batteries are used to operate the teleprinter at Blackpool. The repeaters are fitted with monitoring facilities so that Blackpool can come in circuit with a teleprinter and

- (a) Observe passing signals in one direction at a time,
- (b) Transmit and receive signals to Liverpool or Douglas as required,

- (c) Transmit to Liverpool and receive from Douglas or transmit to Douglas and receive from Liverpool.

International Telex Working. The introduction of the Telex Service by the B.P.O. has increased the interest of other administrations in this method of Teleprinter communication and, in view of the possibility of international working, it is expedient that the administrations concerned should come to an agreement on the carrier frequency.

The carrier frequency used in this country, 300 p.p.s., is on the lower limit of the frequency range of international circuits and, as the range from 400 p.p.s. to 1,300 p.p.s. is used for various signalling facilities, 1,700 p.p.s. is favoured by the German and Dutch administrations. 1,700 p.p.s. is considered to be rather high by the B.P.O., but the possibility of adopting this, or, alternatively, a frequency between 1,300 and 1,700 p.p.s. is now being investigated.

Tariff Y Circuit. This was a circuit designed to work from Telex into a D.C. line. Some difficulty was experienced, due to echo effects, but this was overcome. At each end of the circuit there is a normal Telex converter. At points where the telephone line joins the D.C. line, a unit must be inserted to perform the conversion from A.C. to D.C. or vice versa.

Voice Frequency Duplex (A.C. Mains Case). This system operates on a voice frequency basis and provides a speed of working of 200 w.p.m. over a telephone line (two wire or four wire) provided that overall transmission equivalent does not exceed 30 db. It is similar to the D.C. mains case previously described, but in this case all power is obtained from the A.C. mains.

Leclanché Cells. Investigation has been made of the following methods of reducing evaporation of electrolyte in Leclanché cells: (1) providing the cell with an airtight cover, (2) providing an oil layer on top of the electrolyte, (3) mixing glycerine with the electrolyte. The results show that the use of an airtight cover which effectually reduces evaporation does not reduce the output of a cell when ammonium chloride excitant is used. This method is preferable to the use of oil on account of greater cleanliness.

A report has been issued describing two bridge methods of measuring the inductance and effective resistance of loading coils. The methods described are adapted for rapid and direct reading and have been specially designed for factory tests.

Tests of *specially insulated telephone cables* for use at, or near, E.H.T. Sub-stations have been carried out. At these points there is a dangerous rise in the earth potential during faults on the E.H.T. system; but the tests show that the cables tested will withstand the potential likely to be met with due to faults on present systems. Attention is, however, drawn to the necessity of providing a distant earth on the sheath when the cable is provided with a lead sheath.

Notes and Comments

Mr. R. Shepherd

WE regret to record the death at Constantinople, after a painful illness, of Mr. Robert Shepherd, one of the pioneers of the British telephone system. Mr. Shepherd was born in 1860 and, after receiving his education at Queen's College, Belfast, and Edinburgh University, he entered the service of the Scottish Telephone Exchange, Limited, in 1880. He was sent by this Company to Belfast to open the first exchange in Ireland. After acting as Assistant Engineer to the National Telephone Company (which had acquired the Scottish Company) Mr. Shepherd went to Italy, where he did pioneer work for the Anglo-Continental Telephone Company in Florence, Bologna and Leghorn. In 1886 he rejoined the National Telephone Company and was appointed District Manager for Ulster. In 1896 he was appointed Provincial Superintendent for the West of England, subsequently being moved to the more important North Western District with headquarters at Liverpool. He held this Superintendship until the transfer of the Company's system to the Post Office on 31st December, 1911. Mr. Shepherd has latterly been living in retirement at Constantinople. In his pioneer days in Ireland, and especially in Italy, Mr. Shepherd had to train his own men, design various telephone accessories, and overcome many of the difficulties incident to an entirely new art which he did with exemplary skill and patience.

Mr. Arthur Edward Salmon

We regret to have to announce that Mr. Arthur Edward Salmon, Chairman of W. T. Henley's Telegraph Works Company, Ltd., died suddenly on the morning of April 6th at his residence "Brooksbury," Bourne End, Bucks.

Mr. Salmon was born on 5th March, 1865. He joined Henley's as Secretary in April 1894, was appointed a Director on July 9th, 1926, acting especially in the capacity of Financial Advisor to the Board. He was elected Chairman of the Company on April 1st, 1932.

The interment took place at Little Marlow Church on April 8th. A memorial service was held at the Church of St. Sepulchre, Holborn Viaduct, on April 11th.

Copies of Earlier Volumes of the Journal

The Board of Editors has on hand a number of copies of earlier issues of the Journal. Copies of Vols. 1, 5, 6, 7, 8, 9, 10, 11, 13, 14, 16, 17, 21, 22 (Parts 3 and 4 only), 23, 24 (Parts 2, 3 and 4 only) and 25 (Parts 1, 2 and 4 only) may be obtained, price 1/- per Part (1/3 post free) on application to the Managing Editor.

Storm Damage

The snowstorm of last February caused extensive damage to the Department's overhead routes, particularly in South Wales, and the article by Capt. J. G. Hines, on page 133 of this issue, describes the expedition with which the affected routes in this part of the country were made serviceable. It is interesting to observe how widespread was the damage occasioned by storms during this period, as evidenced by the following extract from an American journal:—

"Beginning on March 18th, a storm blanketed practically the whole country and developed a variety of troubles. Sleet and snow caused heavy casualties in open lines throughout New York, Michigan, Wisconsin, Minnesota, and the Northwest. Heavy rains, flooding the Ohio and other rivers, put part of our lines under water. An electric storm caused damage to the cable at Charlotte, N.C., and badly crippled communication with Florida and other parts of the South."

Birthday Honours List

His Majesty the King has been pleased to confer the following honours upon members of the P.O. Engineering Department:—

I.S.O.

Mr. John Hedley, Staff Engineer, Engineer-in-Chief's Office.

M.B.E.

Mr. J. Hodgetts, Assistant Engineer, Swansea.

MEDAL OF THE ORDER OF THE BRITISH EMPIRE.

Mr. F. Taylor Bird, Inspector, Nottingham.

Mr. A. E. Smith, S.W. Cl. II., Sheffield.

District Notes

London District

THE MONETARY AND ECONOMIC CONFERENCE.

Scarcely more than four weeks prior to the opening of the Conference the Geological Museum Building at South Kensington comprised bare walls and floors, but with commendable speed the Office of Works have rendered it a magnificent building complete with a scheme of decoration in keeping with the dignity of the Conference. With a demand no less pressing upon the Post Office, the telephoning of the building, involving a task of considerable magnitude and importance, has been carried out to schedule. The special requirements for the Conference, the need for avoiding the cutting away of walls, the restriction of surface wiring inside the building left no alternative but to run the bulk of the cabling and leads on the outside walls.

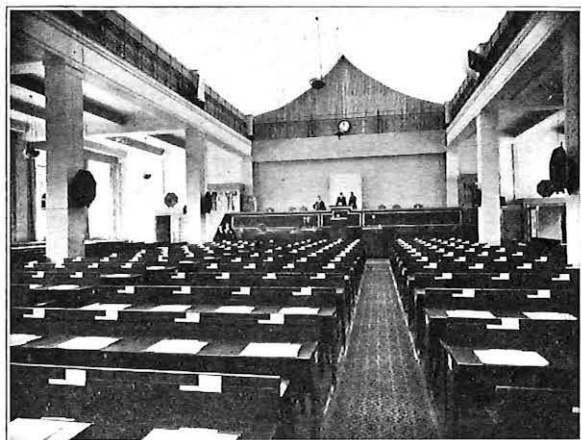

MAIN CONFERENCE HALL.

The main Conference Hall is an impressive feature of the building. It provides seating for 168 Delegates and 144 Diplomats, Economic Experts and Press representatives and there is limited accommodation for the Public. On either side of the Rostrum at the Western end of the Hall are the B.B.C. and Marconi Enclosures. Loud speakers on each main pillar provide speech amplification and acoustic defects of the Hall have been practically eliminated by the provision of a fabric valerium stretched between the galleries. Accommodation for film operators is provided midway along the Hall on the North side.

On the 1st Floor are the North and South Committee Rooms furnished in the style of the Main Conference Hall and the Refreshment Lounge for the use of the Delegates. A Lounge is also provided on the 2nd Floor. Of artistic interest in the Committee Rooms and Lounges are the valuable wall tapestries which have been lent for the Confer-

ence, some of which date from the XIVth century. The offices and rooms for the President and Secretariat are in the office block at the West end of the building.

The Basement is allocated to the Press, Cable Companies, Post Office, Typists, Book stall, Information and Travel Office.

In order to provide telephone service into the building it was necessary to lay some 300 yards of duct from Queens Gate to the rear of the building and in all over 4 miles of telephone cable have been run for the various services, equivalent to approximately 180 miles of single wire. In addition spare wires and junctions have been allocated for the various private wires and External Extensions.

The services in the building are for the most part controlled from a 5-position P.B.X. with 25 exchange lines to Western (Western 7260), 2 lines to Trunks and 20 tie lines to the Foreign Office and

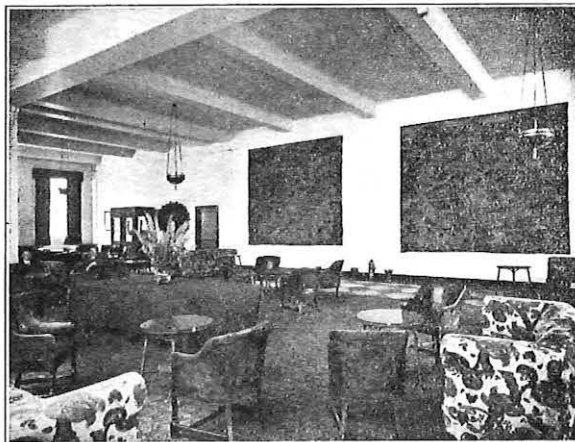

DELEGATES' LOUNGE.

various hotels. The first work performed by the West Internal Section L.E.D. was to modify the No. 9 Boards from C.B. to Auto working. There are 112 direct extensions on the P.B.X., 23 of which are installed in Cabinets. In addition there are 15 Plan No. 7's and 1 Plan 1 Extension.

27 Multi-Coin boxes in Cabinets are installed, 11 of which have direct lines to Western Exchange: the remaining 16 are for the use of the Press and are connected via a special Control Board to Western Exchange, the Press number being Western 8160. In addition there are 15 Call Boxes working to Trunks via a second Control Board. These two Control Boards near the Press Room were designed in the Superintending Engineer's Office and wired by the staff of the West Internal Section.

Amongst the suite of Cabinets in the Basement are 3 for private wires provided for the Cable Companies with Plan 1 Extensions to the Companies' stands. Two other cabinets are connected to the

P.B.X. via one of the Special Control Boards and by this means a caller ringing up the main P.B.X. Western 7260 and requiring the Press, is switched through to the Control Board thus obviating the necessity for the caller to ring off and call up the official Press number. Over and above these facilities, 12 private wires terminated in Cabinets are provided for the Press and other users. Instructions in English and French for callers are inserted in frames outside each Telephone Cabinet. H.M.T's are in use throughout the building.

The teletypewriter service for the Cable Companies is an important facility and ten machines were installed at the date of opening. An alternative route for these services via Western Exchange has been provided for in case of emergency.

For the Broadcasting Service 5 lines have been provided from the Control Room on the 1st Floor to



P.B.X. SWITCHBOARD.

Broadcasting House with 12 extensions to the microphones in the Conference and Committee Rooms.

The remaining facility to be mentioned is the Car Park Control and lines to this point have been provided from the front and rear entrance of the Museum with extensions to A.A. boxes at the Car Parks.

In conclusion it should be stated that completion of the work against time has only been possible by reason of the close co-operation maintained between all concerned. The greater part of the work was shared by the West External and West Internal Sections of the London District and with the assistance of the C.T.O. and South Power Sections it is felt that a satisfactory job has been accomplished.

W. F. B.

South-Western District

THE POSTMASTER-GENERAL AT PLYMOUTH.

On May 17th there occurred what was a unique ceremony in the history of the Post Office when at

the Plymouth Guildhall, in the presence of a distinguished company, Sir Kingsley Wood laid by remote control, the foundation stones of:--

The new Plymouth Automatic Telephone Exchange in Norley Yard.

The extension of the Telephone Exchange in Castle Street, Exeter.

The extension of the H.P.O. and Telephone Exchange at Torquay.

This ceremony followed the opening of the new public office at Plymouth Post Office.

The stone-laying operations were primarily controlled by the operation of three press buttons, mounted on a handsome case, bearing the Coats of Arms of Plymouth, Exeter and Torquay. As each button was depressed, a circuit was completed over a trunk line to the distant end. The trunk circuits terminated at a relay Standard B, a switch N.T.17

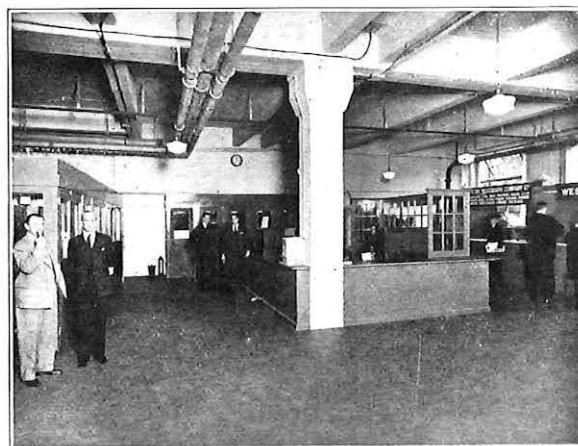

CABINETS, ETC., IN BASEMENT.

being provided in the local circuit. On the operation of the switch, a further local circuit containing a 13-ampere fuse was closed. The foundation stones were each suspended about an inch above their final resting place, being maintained in this position by a counterweight of approximately 25 lb. The arrangements provided that on the blowing of the fuse, the counterweight would fall and release the foundation stone. The receptacle provided to receive the counterweight was fitted with contacts which closed a return circuit, and lit a lamp at the Guildhall, Plymouth, the glowing lamp thus indicating satisfactory operation of the arrangement. A suitable resistance was included in the fuse circuit to ensure an adequate lag between the pressing of the button and the lighting of the lamp, as otherwise these two operations would have been practically simultaneous.

The whole arrangements worked with complete success.

The Postmaster-General then sent telegrams from the Guildhall to the Mayors of Exeter and Torquay. The Exeter message read "Have just laid by

electricity foundation stone of extension of telephone exchange at Castle Street, Exeter, and hope increased facilities will enhance prosperity of your city," and the Torquay telegram was in similar terms. Within a few minutes, telegrams were received from the official observers at each point, stating that they had seen the stones "well and truly laid."

The stone bore the inscription "This Stone was laid by His Majesty's Postmaster-General, the Rt. Hon. Sir Kingsley Wood, M.P., on the 17th May, 1933." In a cavity underneath each stone were placed a dial in a sealed box, and copies of the current telephone directory, a newspaper of the day's date, and the programme of the ceremony.

LANGTREE COUNTRY SATELLITE EXCHANGE.

Telephone service for the majority of the rural areas which are now being developed, is provided by the Rural Automatic Exchanges, but there are, however, areas where owing to the low development figures and the distance of the area from the parent Exchange, the initial outlay is such that some more economical means of affording service is desirable.

It was, therefore, decided as an experiment to offer to those who have supported the R.A.X. proposal, service by means of a new system provisionally called "Country Satellite Exchange," and Langtree in North Devon is the first of such Exchanges to be provided. The Exchange was successfully opened on the 1st June.

Langtree is a small agricultural village approximately 4 miles South-West of Torrington, and service was required by nine subscribers. The length of the longest circuit from the central point is approximately $3\frac{1}{4}$ miles, and the development prospects are small.

The system provides for the subscribers' lines to be led to a series of relays located at some central point. As in the case of an R.A.X., the junction line runs from these relays to the parent exchange but all calls pass over the junction, whereas, in the case of an R.A.X., inter-R.A.X. subscribers' calls are completed without the use of the junction line. Normally about 85% of R.A.X. calls pass over the junction.

When a subscriber on a Country Satellite Exchange desires to make a call, he lifts his receiver and, provided that the junction line is at the time disengaged, he is automatically switched through to the parent exchange where the call, whether to a fellow subscriber on the Satellite Exchange or to a subscriber beyond, is completed. As soon as any subscriber has established connexion with the parent exchange, the lines of other subscribers on the Satellite Exchange are rendered "dead," so that the subscribers have complete secrecy for all calls.

The most convenient pole at the practical centre of the area to be served was selected on which to fit the unit, which consists of two separate relay-sets,

one of discriminating relays and the other of line relays. These sets are jacked into a weatherproof cast iron box and the whole fitted on the pole at a height of about six feet.

With the object of keeping the interior of the cast iron box as dry as possible, a dessicator consisting of silica-gel in a small container is placed in the box.

The telephones fitted at the subscribers' premises are Telephones No. 156 with bell sets No. 21, and these have given excellent transmission results under all tests.

A full description of the circuit operation of this system is given in this issue of the Journal.

RETIREMENT OF MR. J. BAXTER, ASSISTANT SUPERINTENDING ENGINEER.

It is felt that these notes would not be complete without some reference to the unusually sincere and affectionate tributes paid to Mr. Baxter by his colleagues on the occasion of his retirement in March last, after a long and distinguished official career.

Mr. Baxter joined the Service in January, 1887, at Birmingham, and after spending a number of years as a telegraphist, was transferred to the S. Wales District as a clerk. He became a 2nd Class Engineer in 1903, a 1st Class Engineer in 1911, and an Executive Engineer in the same year. He came to the South Western District as Assistant Superintending Engineer in 1928.

A large and representative gathering assembled at a smoking concert at The Prince's Restaurant, Bristol, on March 14th, 1933, under the Chairmanship of the Superintending Engineer, Mr. P. T. Wood, when farewell speeches and presentations were made. The company included Mr. Thompson, Assistant Superintending Engineer, Mr. Rattue (Mr. Baxter's successor); Mr. A. Bristow, District Manager, and Mr. D. Williams, Staff Officer.

After the evening had been opened with musical items, speeches were made by Messrs. Williams, Thomson, Bristow and Rattue, which emphasized the high esteem in which Mr. Baxter was held by the whole of the staff, and echoed the general regret which was felt at his departure, and the universal wish that he might enjoy a long and happy retirement.

The Chairman then presented Mr. Baxter with a number of items of electrical domestic equipment, and in a felicitous speech, referred to the great assistance he had received from Mr. Baxter's sound judgment and experience, and his comprehensive knowledge of the Department's organization.

Mr. Baxter replied in a speech characterized by his usual dry humour and deep insight into human nature. He expressed appreciation of the gifts and, more especially, of the spirit in which they had been given. He said that he was glad he had been able to render any such advice and assistance as his colleagues might have found useful and that he

would always cherish pleasant memories of the staff with whom he had spent his official career.

After supper, an excellent musical programme was provided, and the evening terminated with the singing of Auld Lang Syne.

North-Eastern District

FAREWELL TO MR. J. W. ATKINSON.

On Friday, April 28th, a gathering representative of almost all branches of the Post Office and including a good number of "gallants" from the happy band of retired officers, met at the Guildford Hotel, Leeds, to say farewell to Mr. J. W. Atkinson (Superintending Engineer), N.E. District, on the occasion of his transfer to London as deputy Superintending Engineer.

After an enjoyable concert, which included songs both old and new, the chairman, Mr. W. D. Scutt (Sectional Engineer) proposed the toast of the guest of the evening, and in the course of his remarks

referred to Mr. Atkinson's untiring activities during his 5 years' sojourn in Leeds. Then followed from numerous speakers expressions of warm appreciation of Mr. Atkinson's personality, of his willingness to help on all occasions, of his highly skilled capabilities, and of his human qualities which were in evidence in his dealings with all grades of the staff. He was aptly described as "one of Nature's Gentlemen." Mr. W. Stewart (Asst. Suptg. Engr.) gave tangible expression to the good wishes of the assembly by presenting to Mr. Atkinson a dinner service and a Globe Wernicke Book-case subscribed for by members of the Engineering and Clerical staffs throughout the district and by some of his departmental friends retired and serving.

Mr. Atkinson in reply expressed his thanks for the loyal support and co-operation he had received in all his official undertakings and for the useful gifts. These he said would always serve to offer him happy memories of the North East Engineering District and of the many sincere friendships he had formed there.

Institution of Post Office Electrical Engineers

History of the Post Office Engineering Department

The Council of the Institution has had under consideration the question of arranging for the compilation of a History of the Post Office Engineering Department, but came to the conclusion that it was not possible to undertake such a task at the present time. The Council feels, however, that it would be very unfortunate if information of historical value which is at present available should be lost merely through the lack of any organisation for the collection of such valuable literary material. The Council wishes to announce, therefore, that it has decided to arrange for the filing and indexing of any memoirs or information of historical value which may be offered to the Institution.

Retention of Membership on Retirement

The following members who have retired from the Service have elected to retain their membership of the Institution:—

G. Bailey, 72, Estcourt Avenue, Headingley, Leeds.

J. S. Brown, Longacres, Whiteneep, Romney Extra, Hants.

- W. C. Burbridge, 60, Croydon Road, Penge, S.E.20.
- C. Carruthers, Denton Holme, Appleton Road, Linthorpe, Middlesbrough.
- W. Dolton, 51, Tudor Gardens, West Acton, W.3.
- J. J. Hardie, 1, Falls Grove, Gatley, nr. Manchester.
- T. B. Johnson, 5, Oakwood Drive, Roundhay, Leeds.
- W. J. Medlyn, c/o Midland Bank, 96, Deansgate, Manchester.
- E. Newton, Hillview, Dallin Road, Bexley Heath, Kent.
- W. Stevenson, c/o Strowan, Bolton Crescent, Windsor, Berks.
- J. D. Taylor, 99, Cookridge Lane, Cookridge, Leeds.
- G. S. Wallace, 71, Sholebroke Avenue, Leeds.

Corresponding membership

The following have been elected:—

C. A. K. Jeffery, c/o Electrical Engineer, Public Works Department, Hong Kong.

W. E. Smith, G.P.O., Dar-es-Salaam, Tanganyika.

G. L. Agar, G.P.O., Wellington, N.Z.

H. Collins, c/o Divisional Engineer, G.P.O., Port Elizabeth, S.A.

Local Centre Notes

Scotland East

The fifth general meeting was held on the 14th March, 1933, when a paper, entitled "Repeater Station Developments at Aberdeen since 1926," was delivered by Mr. R. Goodfellow. The lecture was a survey of the progress made from a single carrier current equipment to an up-to-date repeater station. The various stages in repeater development were dealt with at length. The installation of the Aberdeen equipment, with special reference to testing equipment and power plant and the subsequent extension to provide repeater equipment for the B.B.C. services, came under review. The paper concluded with a review of the scheme for the transfer of important aerial trunks to main underground cables, and the difficulties which had to be overcome before the work could be satisfactorily completed. The paper contained a number of illustrative diagrams.

An interesting discussion ensued.

Messrs. Hargreaves and Bryden delivered their paper, "Recent Developments in Underground Construction," at the April meeting. It was followed with great interest and evoked an animated discussion.

VISIT TO THE B.B.C.—SCOTTISH REGIONAL STATION.

This station stands in imposing isolation on a lonely moorland at Westerglen, outside Falkirk, midway between Edinburgh and Glasgow.

It has two transmitters working on approximately equal power. The site, which was chosen after exhaustive field tests, enables them to cover 80% of the population of Scotland. The Station has been built on the same lines as the Regional Stations at Brookman's Park and Moorside Edge, but with certain improvements incorporated.

The visit which was made jointly with the members of the Scotland West Centre proved of exceptional interest.

Scotland West

Six meetings were held during the session at which a variety of subjects were discussed. A good average attendance was maintained. A visit to the Scottish National Broadcasting Station at Westerglen, Falkirk, jointly with the members of the Scotland East Centre, proved a popular termination to the programme.

The membership remains constant. The programme for the ensuing session is engaging the attention of the Committee.

Northern Ireland

Contributions to the programme have, with one exception, been made by members of the Centre and a selection of subjects on the most up to date Tele-

graph and Telephone methods has proved very beneficial to the members.

At the opening meeting of the session held on October 4th Mr. T. Cornfoot, M.I.E.E., Chairman of the Centre, gave a very interesting address on the subject "Modern Industry."

The next meeting, held on November 1st, was the occasion of the visit to the Centre by Mr. W. West, B.A., A.M.I.E.E., of Headquarters Research Department, when he lectured on "Room Noise and Reverberation as Problems in Telephony." The subject, being a new one, created considerable interest and a larger number of visitors than usual attended the meeting. The lecture was much appreciated and provided opportunity for a good constructive discussion in which the visitors joined.

In his opening remarks the Chairman, Mr. T. Cornfoot, referring to his impending departure to Reading, thanked all members and visitors who had contributed to the success of the meetings of the Institution during the time he had been in Belfast.

At a meeting held on 6th December, Mr. T. T. Partridge, M.I.E.E., M.I.Struct.E., was welcomed to the Chair by the Vice-Chairman, Mr. A. H. Jacquest, A.M.I.E.E. Mr. Partridge assured the members he was very pleased to become Chairman of the Belfast Centre, which, he was aware, had been doing excellent work.

A paper, entitled "Voice Frequency Telegraphs," read at this meeting by Mr. A. H. Jacquest, proved a very popular one and was discussed at considerable length.

Mr. W. McL. Gillespie, Telegraph Superintendent, paid tribute to the successful work of the Engineering Department in the installation of Voice Frequency working at Belfast.

Mr. A. S. Colston took for his subject at the next meeting held on the 10th January—"Laying, Loading and Balancing Trunk Cables." The progressive stages of the work were well described and illustrated on the screen; particular interest being added by the introduction of slides depicting the laying of the Carrickfergus cable. The last part of the paper took up the thread of a paper entitled "An introduction to Cable Balancing," given by Mr. A. H. Jacquest in the 1931-32 programme.

This was followed at the February meeting by a joint paper in which Mr. A. McCrossan gave a detailed description of the methods of laying ducts, building manholes, drawing in cables, jointing, arrangement of cables in manholes and lay-out; and Mr. A. Wilson, Draughtsman, linked up the work with the necessary records prepared in the Drawing Office.

At the meeting held on the 14th March a paper, entitled "Carrier Current Telephony," was read by Mr. J. L. Winter. The subject was made very interesting with the aid of lantern slides kindly lent by the Standard Telephone Company. Mr. Winter summarised the system in a manner which was much appreciated.

Junior Section Notes

Edinburgh Centre

The meetings continue to be well attended. At the February meeting Mr. R. M. Henderson, of the Senior Section, gave a paper on the "Installation of an Automatic Exchange." A paper on "Man-hole Construction" was delivered in March by Mr. R. D. Forbes. Good discussions ensued. During April the members visited the "Scotsman" Newspaper Office.

Dundee Centre

A paper on "Automatic Exchange Construction" was read by Mr. W. S. Baxter on the 2nd March. The following night a visit was made to the new Park Automatic Exchange. The paper and visit roused additional interest on this subject. At the last meeting of the session, held on the 31st March, Mr. W. Blyth gave a paper on "Wireless Reception," which evoked a good discussion.

Northern Ireland Centre

The facilities at Queen's University, Belfast, enjoyed by the parent section of the Institution were obtained for the Junior Section and, with assistance in other respects, an excellent programme was carried out. The Section shows a virility which augurs well for the future.

Middlesborough Centre

The Annual General Meeting was held on April 28th, 1933, under the Chairmanship of Mr. J. I. Smith, Sectional Engineer.

The attendance was very good, which has been a feature of all previous meetings.

The membership has been increased during the session from 32 to 36 members.

The balance sheet presented showed a surplus of £2 4s. 6d., which was considered highly satisfactory by the members.

We have been able to arrange during the session

to provide each member with a copy of the papers given, at a charge of 3d. each.

Aberdeen Centre

Interest at this Centre has been well maintained.

On the 28th March, Mr. R. Goodfellow, of the Senior Section, delivered his paper on "Aberdeen Repeater Station Development," which evoked much discussion.

An exhibition of lantern slides illustrating methods of cable-laying by means of the mole drainer took place on the 18th April. Mr. W. J. Eves spoke on the various slides and a number of points were subsequently discussed.

Preston Centre

A most successful session came to a close on Wednesday, the 19th April.

All the papers have been of a high standard. One of the successful features in connection with the formation of the Junior Section has been the hidden talent, which has been brought to light by its members.

We are hoping to have a more successful session next term, and a cordial invitation is extended to all members of the staff, Internal and External, to join.

Glasgow Centre

The Centre was inaugurated on the 16th December, 1932, when a meeting was addressed by Mr. C. Whillis. Mr. Harvey Smith was adopted as Chairman.

Five meetings have been held which have aroused considerable interest over a variety of subjects.

Active steps are now being taken towards the preparation of the programme for the ensuing session.

The membership (40) remains somewhat low in comparison with smaller towns in other districts, but it is hoped that this will be remedied in the near future.

The Secretary is Mr. M. Griffith.

Book Reviews

"Elements of Engineering Acoustics." By L. E. C. Hughes, A.C.G.I., D.I.C., B.Sc., Ph.D. Ernest Benn, Ltd., London, 1933. 150 pages. Price 8/6.

The initials L.E.C.H. have long been familiar to those interested in acoustics, and especially to readers of *The Electrician*; the book which is the subject of this review has therefore been awaited with interest. In it Dr. Hughes gives us an outline of the fundamental principles—and, to quite a wide extent, modern practice—involved in the acoustics of sound-reproducing systems; nor does he concentrate exclusively on acoustics, since one of the

seven chapters is devoted to amplifiers. He is therefore to be congratulated on having covered so wide a field within the compass he has allowed himself.

An excellent feature is the attention that is given to the æsthetic values of the reproduction in relation to the physical shortcomings, *i.e.*, to the distortions introduced by the systems. In particular, the importance of considering the directional properties of the microphones and reproducers used in studios and auditoriums is emphasized. It is, perhaps, a pity that the term "distortion" is not applied more consistently throughout the book; in the index,

specific reference is made to three kinds of distortion only, and two of these are not generally of first importance.

By intention, the book is one of ideas rather than formulæ, but this is not to say that there are not some formulæ included, of the kind useful for reference. In view of his main purpose, the author has, I think, rendered his task somewhat more difficult by a ubiquitous use of the decibel scale, and the consequent focusing of attention on power levels—often when power is not a consideration of primary importance. However, only those readers who are not familiar with the decibel are likely to notice the handicap, and a single reading of the book should be sufficient to remove so unfortunate a deficiency.

The first three chapters give a brief outline of sound and its reproduction, particularly in relation to hearing and to the acoustics of room. Chapter IV. describes a number of types and methods of electro-acoustical measurement. Modern microphones and reproducers, together with available details of their performance characteristics, occupy Chapters V. and VII.; while Chapter VI., on amplifiers, is of very general interest. The book contains eight clear photographs of instruments and apparatus, and is concluded by a well-chosen list of references to other works.

The author has refrained from committing himself to formal definitions of technical terms—wisely, I think, since he avails himself of some of the colloquial expressions with which the art of sound reproducing has recently so enriched our language.

Both the subject itself and Dr. Hughes' method of treating it will appeal to telephone engineers.

W.W.

“The Radio Engineering Handbook,” edited by Keith Hannay, New York; McGraw Hill Book Company. 30/-.

This book comprises twenty-three sections, twenty-two of which have been contributed by specialists in their particular subjects. While this is undoubtedly the best way of obtaining authoritative subject matter, it is subject to the liability of overlapping in the contributions of the various specialists. There is a certain amount of such overlapping in the present work, but not to an extent which detracts from the value of the work.

The first section of nineteen pages consists of mathematical and electrical tables. The copper wire tables are in B and S gauge and will not be very useful to British readers. The table of circuit constants giving L, C, ω , wave-lengths and frequency values is arranged in such a manner that different multipliers have to be applied to the various columns. For example even the frequency and ω columns do not correspond for some unknown reason while no information is given as to the dimensions of the quantities tabulated.

The second section on electric and magnetic circuits deals with the fundamentals of electricity and magnetism alternating currents and radiation. Some of this could have been omitted as a radio engineer could be expected to know fundamentals such as

ohms law; on the other hand, formulæ for computing the capacity and inductance of antennæ would have been useful, but for these the reader is referred to other publications. The third section is on resistance and is written by an engineer engaged in the manufacture of resistors. The article would have been an excellent one for an electrical engineering handbook, but for the radio engineer the question of the high frequency resistance of coils formed of multi-strand and tubular conductors, etc., is very important and this portion of the subject is rather inadequately treated.

Sections 4 and 5 are on inductance and capacity by officers of the Bureau of Standards and contain a good deal of useful information. Section 6, of 40 pages on combined circuits of L C & R, is a particularly useful summary of the properties of combinations of these quantities in alternating current circuits, including coupled circuits, recurrent networks and wave filters. Section 7 is on measuring instruments, and here again the subject of measurement at radio frequencies is inadequately treated although there is a good deal of useful information about low frequency measurements. Section 8 is on vacuum tubes, by an engineer in a receiving valve manufacturing company. It is a useful summary of the properties of receiving valves and omits any reference to transmitting valves. Section 9 is on the design of oscillating circuits, by D. C. Prince, of the General Electric Company, and contains useful information. Section 10 is on detection and modulation and covers the subject fairly thoroughly, a very useful bibliography is included in this section. Sections 11 and 12 are on audio and radio frequency amplifiers respectively. The former includes data on interstage coupling circuits, determination and measurement of distortion and the use of pentodes. The latter section deals with resistance, impedance and transformer coupled amplifiers, methods of avoiding oscillation, power amplifiers and frequency multipliers. Section 13, by G. L. Beers of the R.C.A. Victor Company, deals with receiving systems and covers fairly thoroughly the design of broadcasting receivers. Sub-sections deal with methods of testing, neutralization, superheterodyne sets, gauging of heating oscillators, tone control, automatic gain control and power supply. Section 14, on broadcasting, deals with acoustics, audio frequency systems and transmitters. Section 15 is on rectifiers and power supply systems, while Section 16 is on loud speakers and acoustic systems; this is a useful section and contains a copious bibliography. Hoyt Taylor contributes Section 17, on high frequency transmission and reception, and gives an authoritative summary of the characteristics of short wave propagation. Succeeding sections deal with code transmission and reception, television, facsimile transmission (by Ranger), aircraft radio, photo cells and sound motion pictures. It will be seen from this description that the book covers a very wide field, wider probably than any other work on the same lines and certainly more up to date. It will form a valuable work of reference for the radio engineer.

A.J.G.

Staff Changes

POST OFFICE ENGINEERING DEPARTMENT.

PROMOTIONS.

Name.	From.	To.	Date.
Graham, R. B.	Assistant Engineer, York Section, N.E. District.	Executive Engineer, Leeds External Section, N.E. District.	4-4-33
Wylie, T. O. K.	Assistant Engineer, Telephone Section, E.-in-C.O.	Executive Engineer, Telephone Section, E.-in-C.O.	29-3-33
Harbottle, H. R.	Assistant Engineer, Research Section, E.-in-C.O.	Executive Engineer, Research Section, E.-in-C.O.	2-5-33
West, W.	Assistant Engineer, Research Section, E.-in-C.O.	Executive Engineer, Research Section, E.-in-C.O.	2-5-33
Tolley, L. L.	Assistant Engineer, Research Section, E.-in-C.O.	Executive Engineer, Research Section, E.-in-C.O.	2-5-33
Moller, P. D.	Chief Inspector, Construction Section, E.-in-C.O.	Assistant Engineer, Construction Section, E.-in-C.O.	To be fixed later.
Durkin, T.	Chief Inspector, W. Yorks Internal Section, N.E. District.	Assistant Engineer, Technical Section, N.E. District.	To be fixed later.
Gill, O. W.	Chief Inspector, Research Section, E.-in-C.O.	Assistant Engineer, Research Section, E.-in-C.O.	To be fixed later.
Maltby, A. G.	Inspector, London District.	Chief Inspector, London District.	15-10-32
Chany, F. T.	Inspector, S. Lancs. District.	Chief Inspector, S. Lancs. District.	16-10-32
Critchlow, V. G.	Inspector, S. West District.	Chief Inspector, S. West District.	22-2-33
Smith, A. E.	Inspector, S. Mid. District.	Chief Inspector, S. Wales District.	23-4-33
Harris, S. R.	Inspector, S. West District.	Chief Inspector, S. West District.	To be fixed later.
Prosser, P.	Inspector, London District.	Chief Inspector, London District.	20-12-32
Wallworth, A. R.	Inspector, Lines Section, E.-in-C.O.	Chief Inspector, Lines Section, E.-in-C.O.	5-4-33
Edmondson, J.	Inspector, Northern District.	Chief Inspector, Northern District.	10-2-33
Bateson, E. L. H.	Inspector, Telegraph Section, E.-in-C.O.	Chief Inspector, Telegraph Section, E.-in-C.O.	9-4-33
Hatfield, W. H.	Inspector, Research Section, E.-in-C.O.	Chief Inspector, Research Section, E.-in-C.O.	6-11-32
Power, W. C. S.	Inspector, Research Section, E.-in-C.O.	Chief Inspector, Research Section, E.-in-C.O.	5-3-33
Tetlow, F. E.	Inspector, Equipment Section, E.-in-C.O.	Chief Inspector, Equipment Section, E.-in-C.O.	1-1-33
Freestone, A. G.	Inspector, Equipment Section, E.-in-C.O.	Chief Inspector, Equipment Section, E.-in-C.O.	1-1-33
Flanagan, W. J. C.	Inspector, Radio Section, E.-in-C.O.	Chief Inspector, Radio Section, E.-in-C.O.	4-4-33
Casterton, E. J.	Inspector, Radio Section, E.-in-C.O.	Chief Inspector, Radio Section, E.-in-C.O.	1-10-32
Luck, L. A.	S.W.I., S. Mid. District.	Inspector, S. Mid. District.	4-12-32
Hatch, E. F.	S.W.I., S. Mid. District.	Inspector, S. Mid. District.	8-4-33
Sharp, L. W.	S.W.I., S. Mid. District.	Inspector, S. Mid. District.	22-1-33
Forty, S. C.	S.W.I., S. Mid. District.	Inspector, S. Mid. District.	8-4-33
Buy, H. A.	S.W.I., S. Mid. District.	Inspector, S. Mid. District.	15-1-33
McBryde, H.	S.W.I., N. Eastern District.	Inspector, N. Eastern District.	23-4-33
Poole, H.	S.W.I., N. Eastern District.	Inspector, N. Eastern District.	1-1-32
Cartwright, C. N.	S.W.I., N. Wales District.	Inspector, N. Wales District.	5-3-33
Chislett, G. C.	S.W.I., S. Wales District.	Inspector, S. Wales District.	4-2-33
Frost, J.	S.W.I., S. Lancs. District.	Inspector, S. Lancs. District.	8-2-33
Whittington, F.	S.W.I., N. Mid. District.	Inspector, N. Mid. District.	11-5-33
McLeod, T.	S.W.I., S. Lancs. District.	Inspector, S. Lancs. District.	14-4-33
Jones, C. W.			13-12-32
Chamberlain, A. E.			1-1-33
Thwaites, H. J.			1-1-33
Guy, L.			30-1-33
Hancock, L.			31-12-32
Clarke, G. E.			1-1-33
Soper, D. C.			17-12-32
Arnold, C. W.			10-9-32
Prichard, F. E.			31-12-32
Slater, G. H.			19-12-32
Webb, A. W.			14-1-33
Allsup, E. F. W.			22-4-33
Smith, G. J.			24-10-32
Pride, C. A.			To be fixed later.
	S.W.I., E.-in-C.O.	Inspector, E.-in-C.O.	

STAFF CHANGES

APPOINTMENTS.

Name.	From.	To.	Date.	
*Carter, R. O.	—	Assistant Engineer, Research Section, E.-in-C.O.	27-3-33	
*Mead, F. C.	—	Assistant Engineer, Research Section, E.-in-C.O.	27-3-33	
Turner, A. F.	}	Inspector, Designs Section, E.-in-C.O.	}	
Prescott, J.		Inspector, Telephone Section, E.-in-C.O.		
Goodchild, R. F.		Inspector, London District.		
Harnden, A. B.		Inspector, London District.		
Nicholls, C. A. L.		Inspector, S. West District.		
Owens, W. H.		Inspector, London District.		
Knight, A. R.		Inspector, London District.		
Renton, R. N.		Inspector, Telegraph Section, E.-in-C.O.		
Dunn, W. K.		Inspector, Lines Section, E.-in-C.O.		
Prickett, W.		Inspector, Lines Section, E.-in-C.O.		
Carrette, A. D.		Probationary Inspector (Limited Competition). Inspector, Equipment Section, E.-in-C.O.		1-5-33
Hamilton, D. F.		Inspector, Scot. West District.		
Stonebanks, A. M.		Inspector, Telegraph Section, E.-in-C.O.		
Judson, J. E.		Inspector, Equipment Section, E.-in-C.O.		
Porter, W. F.		Inspector, London District.		
Watling, C. E. C.	Inspector, London District.			
Fairs, A. E.	Inspector, London District.			
Ellenden, A. H.	Inspector, S. East District.			
Pilcher, C. J. F.	Inspector, London District.			
James, L. R.	Inspector, London District.			
Combridge, J. H.	Inspector, Telegraph Section, E.-in-C.O.			
Mayne, E. A.	Inspector, Radio Section, E.-in-C.O.			
Fogg, G. H.	Inspector, Radio Section, E.-in-C.O.			
Trott, L. J.	Inspector, Equipment Section, E.-in-C.O.			
Button, G. E.	Inspector, London District.			
Reed, R. E.	Probationary Inspector (Open Competition). Inspector, N. East District.	1-5-33		
Leach, F.	Inspector, S. Lancs. District.			
Edwards, S. J.	Inspector, S. West District.			
Pugh, S. E.	Inspector, London District.			
Dolan, W. H.	Inspector, Designs Section, E.-in-C.O.			
Maddison, W. H.	Inspector, London District.			
Watson, L. R.	Inspector, London District.			

* From Special Competition.

DEATHS.

Name.	Rank.	District.	Date.
Jarvis, J. W.	Chief Inspector.	Scot. E. District.	17-3-33

TRANSFERS.

Name.	From.	To.	Date.
Tamplin, G. R.	Assistant Engineer, Research Section, E.-in-C.O.	Assistant Engineer, S. Wales District.	3-4-33
Miller, A.	Assistant Engineer, London District.	Assistant Engineer, Construction Section, E.-in-C.O.	26-4-33
Jolley, E. H.	Assistant Engineer, Research Section, E.-in-C.O.	Assistant Engineer, N. Mid. District.	1-5-33
Farnes, G. H.	Assistant Engineer, Radio Section, E.-in-C.O.	Assistant Engineer, Scot. East District.	14-5-33
Taylor, T. A.	Assistant Engineer, Research Section, E.-in-C.O.	Assistant Engineer, London District.	14-6-33

STAFF CHANGES

RETIREMENTS.

Name.	Rank.	District.	Date.
Matthews, J. R.	Assistant Staff Engineer.	E.-in-C.O.	5-4-33
Baxter, J.	Assistant Superintending Engineer.	S. West.	31-3-33
Jackson, C. A.	Assistant Superintending Engineer.	N. Wales.	21-3-33
Burbridge, W. C.	Executive Engineer.	London.	31-3-33
Albry, W. H.	Executive Engineer.	Testing Branch, Birmingham.	13-4-33
Moller, O. P.	Assistant Engineer.	E.-in-C.O.	30-4-33
Lewis, E. A.	Assistant Engineer.	S.E.	31-3-33
Spink, E.	Assistant Engineer.	S. Mid.	30-4-33
Bailey, G.	Assistant Engineer.	N.E.	31-3-33
Roberts, F. H.	Chief Inspector.	N. Mid.	7-4-33
Davison, C. J.	Inspector.	N. Eastern.	21-3-33
Spargo, E.	Inspector.	S. Lancs.	13-4-33
Whitley, W. H.	Inspector.	N. Eastern.	1-6-33

CLERICAL GRADES.

RETIREMENTS.

Name.	Rank.	District.	Date.
Dauncey, A. J. W.	Executive Officer.	E.-in-C.O.	29-3-33
Armstrong, C. P.	Higher Clerical Officer.	Northern.	29-5-33
Everett, A. E.	Higher Clerical Officer.	London District.	2-3-33
MacNally, G. T.	Higher Clerical Officer.	London District.	29-5-33

PROMOTIONS.

Name.	At present.		To be.		Date.
	Rank.	Location.	Rank.	Location.	
Palmer, C.	Clerical Officer.	Newcastle.	Higher Clerical Officer.	Newcastle.	30-5-33
Bott, J. T.	Clerical Officer.	Newcastle.	Higher Clerical Officer.	Newcastle.	23-7-33
Packer, A. G.	Clerical Officer.	Swansea.	Higher Clerical Officer.	Coventry.	
Burton, S. G.	Clerical Officer.	Croydon.	Higher Clerical Officer.	Croydon.	1-8-33
Booth, C. H.	Acting Executive Officer.	E.-in-C.O.	Executive Officer.	E.-in-C.O.	30-4-33
Harrison, A. K.	Clerical Officer.	E.-in-C.O.	Acting Executive Officer.	E.-in-C.O.	30-4-33

BOARD OF EDITORS.

B. O. ANSON, M.I.E.E., Chairman.
 P. J. RIDD, M.I.E.E.
 C. J. MERCER, M.I.E.E., M.I.R.E.
 A. J. GILL, B.Sc., M.I.E.E., M.I.R.E.
 H. G. S. PECK, B.Sc., M.I.E.E.
 J. T. KELLY.
 J. INNES, B.Sc., M.I.E.E., Managing Editor.
 W. S. PROCTER, A.M.I.E.E., Assistant Editor.

COMMUNICATIONS.

All Remittances and Communications should be addressed to the MANAGING EDITOR, P.O.E.E. JOURNAL, Engineer-in-Chief's Office, Alder House, London, E.C.1. Telephone: NATIONAL 6321 (P.B.X).

Binding covers and copies of the Contents for Vol. 3 to 25 are available, and may be obtained from the local agents for 1s. 6d. and 3d. respectively. Subscribers can have their copies of Vol. 25 bound, with index included, at a cost of 3s. by sending the JOURNALS to the local agents. Orders for bindings, Vols. 1—19, should indicate whether the original binding with black lettering, or the latter pattern in gold, is required. Covers with gold lettering will be the only type stocked from Vol. 20 onwards.

The price of the JOURNAL is 1s. (1s. 3d. post free) per copy, or 5s. per annum, post free. All back numbers 1s. each, (1s. 3d. post free).

JOIN

the **Institution of Post Office Electrical Engineers** and enjoy the facilities provided by the Institution for its members. The Junior Section caters specially for the Skilled Workmen and Youths of the P.O. Engineering Department.

Enquiries from prospective members should be addressed to :—

The Secretary,
I.P.O.E.E.,
Alder House,
London, E.C.1.

READ

the **Post Office Electrical Engineers' Journal** and keep up to date in the many developments in the theory and practice of Communication Engineering. Subscription Terms :—4/- per annum (5/- post free).

Enquiries should be addressed to :—

The Managing Editor,
P.O.E.E. Journal,
Alder House,
London, E.C.1.

G.E.C.

Manufacturers of

**BRITISH POST OFFICE
AUTOMATIC E**

*Foremost
throughout
the World*



**THE GE
TELEPH**

BRANCHE

CE STANDARD XCHANGES

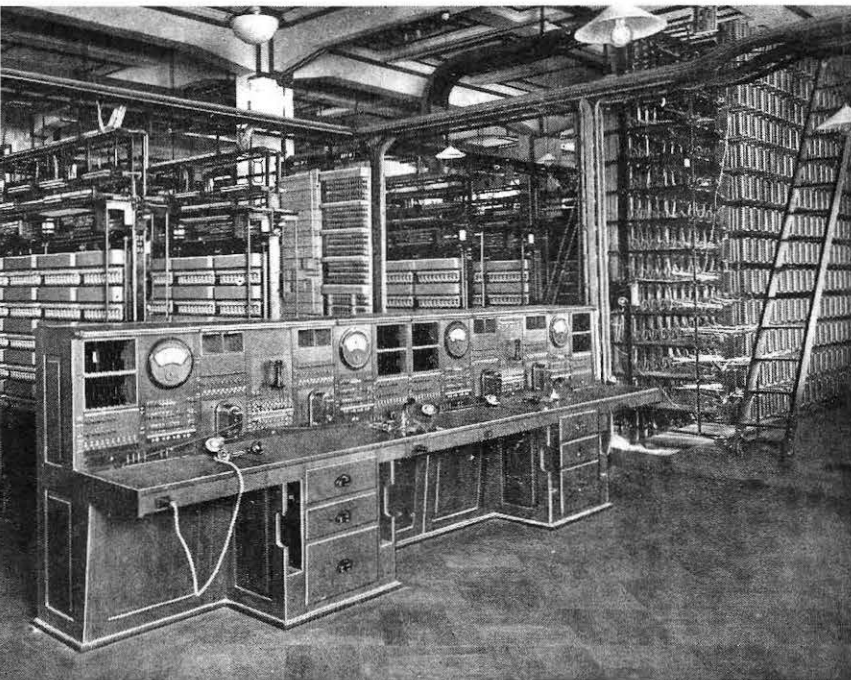

Singapore Automatic Exchange, capacity 9,300 lines.

The Strowger Linefinder System standardised by the British Post Office satisfies every service requirement and offers the advantages of simplicity, proved reliability, and economy in space, weight and maintenance.

GENERAL ELECTRIC COMPANY LIMITED
WORKS COVENTRY

Head Office: **MAGNET HOUSE, KINGSWAY, LONDON, W.C. 2.**

& AGENCIES IN ALL PARTS OF THE WORLD

INDEX TO ADVERTISERS.

	PAGE		PAGE
Automatic Telephone Mfg. Co., Ltd	iii to x	Pitman & Sons, Ltd.	... xi
Ebonestos Insulators, Ltd. ...	xxi	Standard Telephones & Cables, Ltd.	... xviii
Elliott Brothers, Ltd. ...	xxiii	Siemens Bros. & Co., Ltd.	... xiv & xv
Ericsson Telephones, Ltd. ...	xiii	Smith, Frederick & Co	... xxiii
Ernest T. Turner ...	xvii	Telephony Publishing Corp. xxi
Hall Telephone Accessories (1928), Ltd.	xxi	The Alton Battery Co, Ltd. ii
Henley's, W. T., Telegraph Works, Co., Ltd.	xvii	The Electrical Review	... xii
I.P.O.E.E. ...	xi	The General Electric Co., Ltd.	xvi, xx & xxi
Pirelli-General Cable Works, Ltd. ...	xxiv		

Hall Telephone Accessories (1928) Limited.

Suppliers to the British Post Office and
Foreign Government Departments.

Manufacturers of prepayment telephone
multi-coin collectors, automatic stamp
selling and ticket selling machines,
automatic slot machines and fire alarm
apparatus.

Registered
Office & Works : 70, DUDDEN HILL LANE,
WILLESDEN,
LONDON, N.W. 10

Tel.: WILLESDEN 5141/2.

Moulders to the Trade

*Established
30 Years*

MOULDINGS
IN WHITE OR
COLOURS.
BAKELITE —
BEETLE —
CELLULOSE
AND OTHER
SYNTHETICS.

PLASTIC MOULDINGS HAVING
HEAT — ACID — OIL — ALKALI —
WATER RESISTING QUALITIES.

EBONESTOS INSULATORS LTD
Excelsior Works,
Rollins Street,
Canterbury Road,

Telephone
NEW CROSS 1913 (5 lines) **LONDON, S.E.15.**

The cover of the journal 'Telephony' is red with white text and illustrations. At the top, the word 'Telephony' is written in a stylized, cursive font. Below the title, there are several small advertisements and technical diagrams. One prominent ad is for 'Perfected Standard Wire' by 'The Mac Gillis & Sons Co.', which includes an illustration of a wire spool. Other ads include 'EVERSTICK ANCHORS', 'DEPENDABLE WHITE CEDAR POLES', 'ORIENTAL LAC SCREENS', 'TELEPHONE CABLES', and 'MAC GILLIS CEDAR POLES'. The bottom of the cover features the name 'THE MAC GILLIS & SONS CO.' and 'LONDON'.

OF INTEREST TO ALL TELEPHONE ENGINEERS

Articles on every conceivable subject, having to do with telephone engineering, design, construction and maintenance are published in the weekly issues of TELEPHONY. That is why this journal is read by progressive telephone men throughout the world. TELEPHONY has been the leader in its field for over thirty-two years. Subscription price £1 5s. for fifty-two interesting and instructive issues.

Address: Electrical Trading and Electricity Technical Book Dept., 85,
Long Acre, London, W.C. 2, for a sample copy of TELEPHONY.
TELEPHONY PUBLISHING CORP., 608, S. Dearborn St. Chicago, Ill., U.S.A.

TELEGRAPH APPARATUS

OF
 EVERY
 DESCRIPTION
 for
 RACK OR TABLE
 MOUNTING

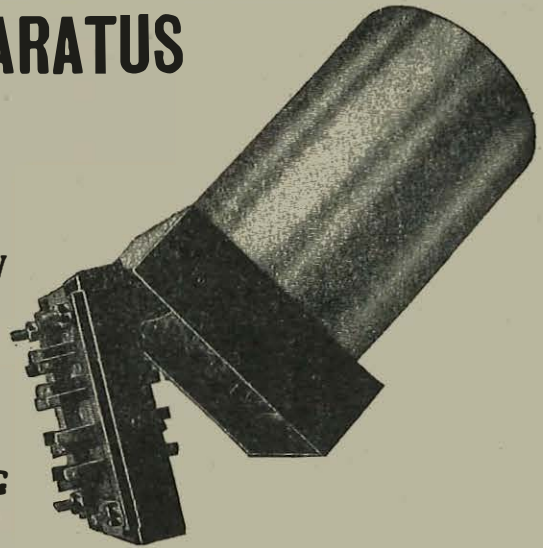
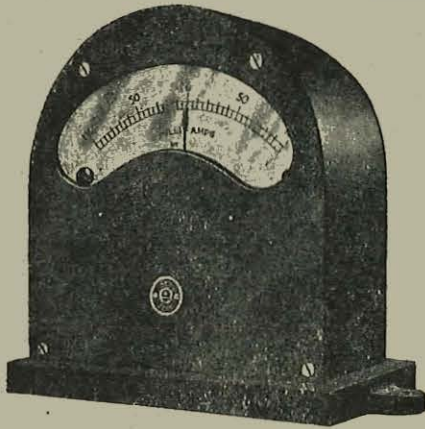

including :—

Differential Moving Coil Milli-
 ammeter for Telegraph Cir-
 cuits, Table Mounting Type.
 Wall and Panel Mounting
 Types can also be supplied.

KEYS, SOUNDERS, RELAYS, GALVANOMETERS,
 MILLIAMMETERS, RHEOSTATS, ARTIFICIAL
 LINES, TRANSMITTERS, RECEIVERS, TEST SETS,
 AND COMPLETE LAND-LINE EQUIPMENTS.

Telegraph Vibrating Relay
 mounted on Base with Sub-
 base. Embodies several im-
 portant improvements on the
 old types of Post Office Relays.

Particulars on application.

ELLIOTT BROTHERS (London) LTD., Century Works, Lewisham, S.E.13 Telephone: Lee Green 4646

in association with

SIEMENS BROTHERS & COMPANY, LIMITED, Woolwich, London, S.E.18 Telephone: Woolwich 1161

ANACOS

REGISTERED

BRONZE & CADMIUM COPPER WIRES

SEND US PARTICULARS
 OF YOUR JOB, AND OUR
 TECHNICAL ENGINEERS
 WILL PROVIDE YOU WITH
 THE DATA YOU NEED.

as supplied
 to H.M. Post Office for
TELEPHONE LINES

SILICIUM-BRONZE, COPPER

COPPER - CADMIUM

TAPES & BINDERS

FREDERICK SMITH & COMPANY

INCORPORATED IN THE LONDON ELECTRIC WIRE
 COMPANY AND SMITHS. LIMITED
 ANACONDA WORKS SALFORD 3, LANCs.
 Telephone: Blackfriars 8701 (8 lines) Telegrams: "Anaconda, Manchester."

MINUTES MEAN MONEY!

24 MILES OF DOUBLE STEEL TAPE ARMoured STAR QUAD TRUNK TELEPHONE CABLE COMPLETE WITH THE **GENERAL ELECTRIC CO'S** LOADING COILS, HAVE BEEN MANUFACTURED AND INSTALLED FOR THE BRITISH POST OFFICE TO REPLACE LINES DAMAGED IN THE RECENT BLIZZARDS.

MANUFACTURING TIME **2** *Weeks*

INSTALLATION TIME **2** *Weeks*

TELEPHONE
SOUTHAMPTON
2141 (3 LINES).

PIRELLI-GENERAL
CABLE WORKS, Ltd., SOUTHAMPTON.

TELEGRAMS:
"PIGEKAYBEL,
SOUTHAMPTON."

Proprietors: PIRELLI, LTD., and THE GENERAL ELECTRIC CO., LTD.