

# British Telecommunications Engineering

---

VOL 7 PART 3 OCTOBER 1988



The Journal of  
The Institution of British Telecommunications Engineers

Published in April, July, October and January by *British Telecommunications Engineering Journal*, 2-12 Gresham Street, London, EC2V 7AG. (Formerly *The Post Office Electrical Engineers' Journal* Vols. 1-74: April 1908-January 1982.)

The Board of Editors is not responsible for any statements made nor the opinions expressed in any of the articles or correspondence in this *Journal*, unless any such statement is made specifically by the Board.

© 1988: The Institution of British Telecommunications Engineers.

Printed in Great Britain by Unwin Brothers Limited, The Gresham Press, Old Woking, Surrey GU22 9LH.

#### Subscriptions and Back Numbers

Price: £1.50 (£2.00 including postage for UK; £2.50 including postage for overseas). Annual subscription (including postage and packaging): £8.00 (UK); £10.00 (overseas). Overseas customers can pay by sterling drafts drawn on London for £10.00. Payment by cheque drawn in US dollars will be accepted at the price of \$22.00 to cover bank charges.

Price to British Telecom and British Post Office staff: 90p per copy.

Back numbers can be supplied if available, price £1.50 (£2.00 including postage for UK; £2.50 including postage for overseas).

Orders, by post only, should be addressed to *British Telecommunications Engineering Journal* (Sales), Post Room, 2-12 Gresham Street, London EC2V 7AG.

Remittances for all items (except binding) should be made payable to 'BTE Journal' and should be crossed '& Co.'.

#### Advertisements

All enquiries relating to advertisement space reservations should be addressed to The Advertisement Manager, *British Telecommunications Engineering*, 3rd Floor, 84-89 Wood Street, London EC2V 7HL. (Telephone: 01-356 8050.)

#### Communications

With the exceptions indicated, all communications should be addressed to the Editorial Office, *British Telecommunications Engineering*, 3rd Floor, 84-89 Wood Street, London EC2V 7HL. (Telephone: 01-356 8050; Fax: 01-356 8051; Gold Mailbox: 73:TA1009.)

#### Binding

Readers can have their copies bound at a cost of £11.25, including return postage, by sending the complete set of parts, with a remittance, to Press Binders Ltd., 4 Iliffe Yard, London SE17 3QA.

#### Copyright

The entire contents of this *Journal* and the *Supplement* are covered by general copyright and special permission is necessary for reprinting long extracts, but editors are welcome to use not more than one-third of any article, provided that credit is given at the beginning or end, thus: 'From *British Telecommunications Engineering*'.

Authorisation to photocopy items for internal or personal use, or the internal or personal use of specific clients, is granted by the *British Telecommunications Engineering Journal* for users registered with the Copyright Clearance Center's (CCC's) Transactional Reporting Service, provided that the base fee of \$2.00 per copy is paid directly to CCC, 27 Congress Street, Salem, MA 01970, USA. For those organisations that have been granted a photocopy license by CCC, a separate system of payment has been arranged. Payment is additionally required for copying of articles published prior to 1978.



# British Telecommunications Engineering

## Contents

VOL 7 PART 3 OCTOBER 1988

<b>Editorial</b>	161
<b>The Mezza System</b> R. E. Walters, G. D. Roxburgh, and D. Newey	162
<b>Rural Telecommunications in a Third World Country</b> E. J. Welsh, and D. deCruz	172
<b>Using CEDRIC to Commission System X Concentrators</b> R. A. Startin, R. F. Booth, B. B. Trawford, J. C. Denny, and J. Barnes	179
<b>The Physical Design of Antenna Support Structures — State of the Art</b> D. G. Clow	187
<b>Towards a European Telecommunity</b> A. Boesveld	194
<b>Common European Objectives</b> P. C. Jones	200
<b>Moling and Other Trenchless Techniques Used in British Telecom — An Overview</b> A. W. Renshaw	205
<b>Product News</b>	
British Telecom Launches Poet — A Manager/Secretary Communications System	209
X.400 For DEC Users	209
<b>British Telecom Press Notices</b>	
Ultra-Modern Control Centre for London's Network	210
Optical-Fibre Breakthrough	210
British Telecom's Public Telephone Revolution	211
Major Computing and Communications Companies Form International Association	211
British Telecom Office Automation will Boost Efficiency	212
Automated Manufacturing Data On-Line	212
£200M Extension for Fibre Network	213
<b>Notes and Comments</b>	214
<b>Institution of British Telecommunications Engineers</b>	216
<b>Book Reviews</b>	221

# British Telecommunications Engineering

---

## BOARD OF EDITORS

J. Tipler, Chairman

W. Carlyle

P. B. Frame, C.ENG., F.I.E.E.

I. G. Morgan, B.SC., C.ENG., M.I.E.E.

G. White, B.SC., PH.D., SEN.MEM.I.E.E.E.

R. N. Williams, B.A., I.ENG., M.I.ELEC.I.E.

## Managing Editor

V. L. Dunhill, B.SC., C.ENG., M.I.E.E.

## Deputy Managing Editor

P. E. Nichols, B.SC.

## Secretary-Treasurer

C. H. G. Fennell

## EDITORIAL

The Single European Act committed the member nations of the European Community to the removal of all commercial and trading barriers by the end of 1992. It was realised that industry, particularly the high-technology industries, were losing ground in the world markets and that the fragmented market within Europe, together with its national trade barriers, differing national standards and administration requirements were increasing costs. The aim is to create a single market of over 320 million people, the largest in the world, as a base from which the European manufacturers can effectively challenge the international competition. Telecommunications, information technology and broadcasting will play a major role in this strategy and a number of initiatives have been identified. One of these initiatives, on standards, has already been implemented with the creation of the European Telecommunications Standards Institute (ETSI). Technical harmonisation and the creation of standards are vital to the achievement of the 1992 goal and there will be much activity over the next few years; it is imperative, therefore, that UK industry makes proper representation to this standards-making process. Two articles in this issue of the *Journal* look at telecommunications in Europe. One reviews the developments in European co-operation on standardisation activities and examines the role of the European Commission. The other explores the broad objective of British Telecom in relation to the liberalisation of telecommunications in Europe.

# The Mezza SYSTEM

R. E. WALTERS, G. D. ROXBURGH, and D. NEWEY

UDC 621.395.65

*Mezza is a voice-integrated computer system, with voice/data terminals called VoiceStations, which, in association with a PABX, offers an extensive range of information-technology facilities in the fields of digital telephony, voice and text processing, and computing. This article provides an overview of the system and its facilities, followed by a detailed description of its hardware and software implementation.*

## INTRODUCTION

The Mezza system combines digital telephony, voice and text messaging, and UNIX®-computing in a single highly-integrated product which operates with any PABX. It is a natural offering for any telecommunications authority, successfully bridging the two related worlds of computing and telephony in a meaningful and practical fashion. The system has extraordinary depth and flexibility; its power and versatility can only be fully appreciated by hands-on experience.

Mezza is a BT product in its entirety. BT develops, supports, manufactures and exports the system. The design originated in California's Silicon Valley and was acquired by BT in 1986. Since then, the system has been significantly improved in all areas, and this process continues. It remains a unique offering in the field of information technology, combining most, if not all, of the functions required at individual desks into a cohesive departmental system.

## SYSTEM OVERVIEW

Mezza consists of a voice-integrated multi-processor computer, a star topology local area network using standard telephone wiring, and voice/data terminals called *VoiceStations*. A single system can be configured for any number of VoiceStations between 8 and 96, and allows the use of other terminals including personal computers (PCs) and the plain old telephone. Mezza's overall structure can be viewed in Figure 1.

A central UNIX-based computer system, the system information manager (SIM), is located between the PABX and the VoiceStations. Connection to the PABX is via standard analogue 2-wire extension connections, and hence Mezza can function in association with all PABXs. Digital voice and high-speed data are communicated simultaneously from and to the workstation over standard single twisted-

pair wiring up to a distance of 1 km. A remote terminal user can access the system by dialling in through a shared modem. IBM or compatible PCs and VT100 terminals are connected to the system via special digital telephone interfaces or simply by connection to serial data ports.

A system console can be connected to the SIM to receive fault reports, to alter the system configuration and to back up disc-based information to tape.

As shown in Figure 1, access can be provided to a multiplicity of external services through standard serial links. This method of connection also allows Mezza systems to be networked such that users on remote systems can communicate.

Figure 1  
Mezza connectivity

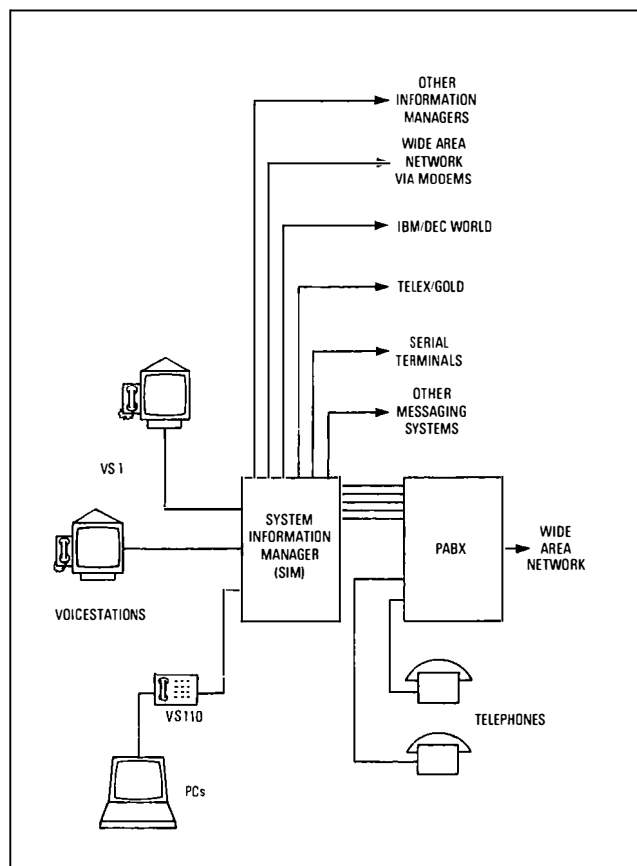

† Computer Integrated Telephony Group, British Telecom International Products Division

## FUNCTION OVERVIEW

Screen-based multiple-line telephony with soft-key access to PABX features, directory, message slip and other facilities are provided through a real-time operating environment to ensure instant response. Telephone calls can be made directly from a keypad, via single keys or from a departmental or personal directory.

Manager/secretary working is an important feature of the system with full line status and intercom facilities. The secretary can answer unattended VoiceStations for a number of managers. A visual indication of whose line is being answered is given to permit a personalised response, and an automatic message slip can be displayed to allow a message to be taken and promptly dispatched to the in-tray of the owner of the called line.

Office automation functions are provided through a uniquely friendly icon-based DeskTop environment (see Figure 2) presenting the following functions:

*Filing Cabinet* in which text/speech and graphics can be stored as individual files or in folders.

*In and Out Tray* for voice, data, text and graphics.

*Word Processor* with voice annotation and all commands on soft keys.

*Spreadsheet* with business graphics.

*Database Manager* an interface to an industry-standard relational database.

*Message Slip* for short voice or text messages.

*Calendar* personal and shared diaries.

*Calculator* simple or financial.

*Voice Editor* for voice messages dictation and voice annotation.

*Data Access* to other systems and services.

A VoiceDesk facility provides voice messaging and answerphone facilities to both

VoiceStation and ordinary telephone users.

One simple example of using the Mezza system is the preparation of a letter by voice. Referring to Figure 2, the supply cabinet is opened (first icon) and the voice editor selected. A manager can use this to dictate a letter, and then mail it to a secretary. The secretary transcribes the letter into the word processor (making use of a headset and foot-switch) and mails the finished document back to the manager for checking. The manager can annotate the text displayed on the screen by voice and return it for final editing to the secretary. The point to note is that the manager does not need to use a keyboard at all nor have a detailed knowledge of word processors, and only the final copy is committed to paper, for signature.

Selections from the DeskTop can be made by using a mouse, cursor-control via the keypad or numeric control from the telephone keypad. Most functions are carried out by a single operation of a soft key, all of which are context related. Only those functions that are relevant to the task in hand are offered.

The interface has a multi-window capability such that, for example, one's diary can be viewed whilst engaged in a telephone conversation and on completion the screen returns to an interrupted spreadsheet session.

The wealth of operating mechanisms provides for all tastes and skill levels, making the system easy to use and reducing user training to a minimum.

## MEZZA TERMINALS

Two terminals are currently available: VoiceStation 1 (VS1), a self-contained fully-integrated voice and data terminal that can be used with or without a keyboard, and VoiceStation 110 (VS110), which provides much of the VS1 functionality on IBM-compatible PCs or dumb terminals. Dumb terminals can also be connected directly, or through modem links, to conventional serial links in which case the normal DeskTop facilities described above are available, but without the benefit of voice facilities. Any telephone connected to the switched telephone network can become a terminal by virtue of the voice messaging facilities mentioned above.

### VoiceStation 1

This unusually shaped terminal is shown in Figure 3. It consists of an integral telephone with loudspeaking capability together with a high-resolution screen bordered by two sets of embedded keys. The terminal is mains powered.

The vertical keys to the left of the screen have fixed functions. The top five provide:

- Window switching
- Telephone window selection
- Loudspeaking option

Figure 2  
Mezza DeskTop  
environment

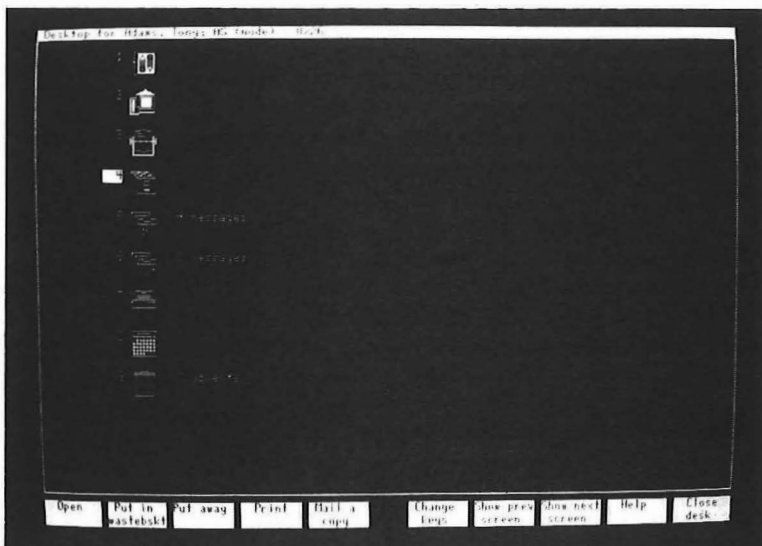

Microphone mute  
Line hold.

The lower five are line keys and can be configured as:

PABX extension lines

Floating lines (to answer calls to a group of extensions)

Intercom lines (for direct connection of Mezza terminals)

When in use, a telephone window appears on the screen beside these keys indicating the function of each line, its status and identity.

The horizontal keys below the screen are soft keys. Their function is determined by individual windows on the screen immediately above them. The function of these keys varies according to the task in hand. For example, when making or receiving a telephone call, the functions offered are the conventional call-handling facilities of the PABX plus entry to the directory and the option to leave a voice or text message (see Figure 4, note that the telephone window is currently active on the left of the screen). The single key on the right gains entry to the DeskTop.

Various optional peripherals can be connected to the VSI:

- Keyboard with standard QWERTY keys plus duplicated soft keys.
- Mouse for cursor and window movement plus function selection.
- Footswitch and headset for transcription of recorded dictation.
- Printer for local printing.

Although a number of local functions are dealt with within the terminal, all applications run within the SIM and multiple applications can be active. The management of windows is a terminal function with window size and position being optional. Figure 4 provides a good example of multiple windows in use.

Communication to the SIM is through a standard single twisted-pair cable. Speech is converted to 64 kbit/s PCM at the terminal, hence requiring a bi-directional 64 kbit/s channel. All other data including signalling is packaged into three other 64 kbit/s channels. The four channels are Manchester† encoded before transmission to line to produce, together with error detection and framing signals, a composite line rate of 320 kbit/s. Full duplex working is achieved by a simple electronic two-to-four-wire converter.

Figure 5 provides a functional breakdown of the individual modules of the VS1 terminal. The video deflection board contains the power supply and CRT drive circuitry. It is situated at the base of the terminal and is therefore triangular in shape. The processor board,



Figure 3—VoiceStation 1

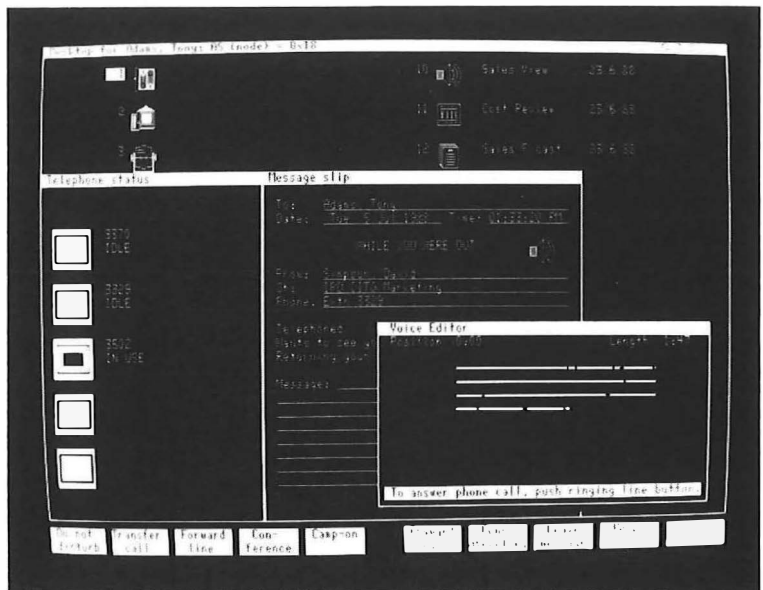

Figure 4—Multiple windows in use

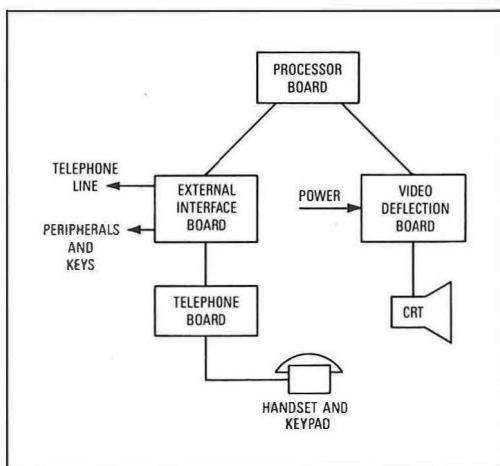

Figure 5  
VoiceStation 1 modules

† Manchester encoding is a means of transmitting binary data combining simple clock extraction with zero DC component.

which contains a Motorola 68008 CPU and video encoding logic, is mounted vertically on one side of the CRT whilst on the other sits the external-interface board which interfaces to line via a hybrid circuit and transformer, and to the various peripheral sockets mentioned above. In addition, this board performs analogue-to-digital conversion of the speech signals. The telephone board is mounted within the telephone assembly and controls the loudspeaking telephone functions, the telephone keypad and magnetic switch-hook. The terminal is very compact having a footprint comparable to a conventional telephone. The modules described above are neatly assembled into the triangular frame; a small fan is provided for cooling, but is disabled during loud-speaking telephony.



Figure 6—VoiceStation 110

### VoiceStation 110

The VS110 (Figure 6) provides a means of integrating IBM-compatible PCs or VT100-compatible terminals into the Mezza system. It is a digital telephone with an RS232 interface via which the external terminal is connected. Connection to the SIM is identical to that provided for the VS1; that is, via standard twisted-pair cable and using the 320 kbit/s duplex transmission scheme.

The five line keys are available at the VS110, status being indicated by associated LEDs. The PABX functions are provided as hard keys on the VS110. These are:

- Recall
- Hold
- Transfer
- Forward
- Call Back
- Conference
- Do Not Disturb.

In addition, a MESSAGE WAITING LED is provided.

DeskTop softkey windows are presented on the screen and are actuated by the function keys of the associated terminal. If a PC is in use, then an emulation software package is loaded. This provides much of the VS1 functionality plus the ability to access files within the PC from the Mezza DeskTop. This function, *PC Cabinet*, allows PC resident files to be mailed to any other Mezza user or to be transferred into the SIM resident filing cabinet.

Internally, the VS110 has two boards: a processor board and an external-interface board. The processor board controls the keypad and LEDs and is linked to the interface board which has connections to the RS232 terminal socket, the telephone line and the handset. The VS110 is powered by an external low-voltage supply.

### INFORMATION MANAGER HARDWARE

The system information manager (SIM) is a floor-standing cabinet about the size of a three-drawer filing cabinet (see Figure 7) which houses: a multi-layer backplane, a 19-slot card cage (to accept system slide-in units), two Winchester disc drives, and an archival tape drive. The power supply and associated power distribution panel are mounted on the SIM rear service door. Access to the slide-in units and disc drives is gained via a removable front panel.

Figure 7  
System information manager

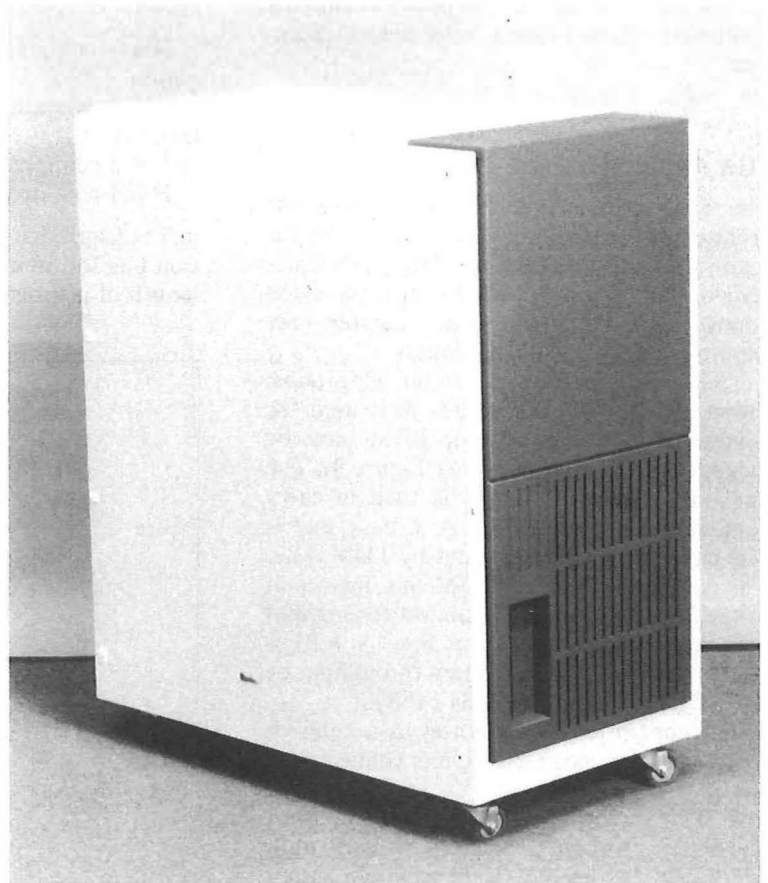



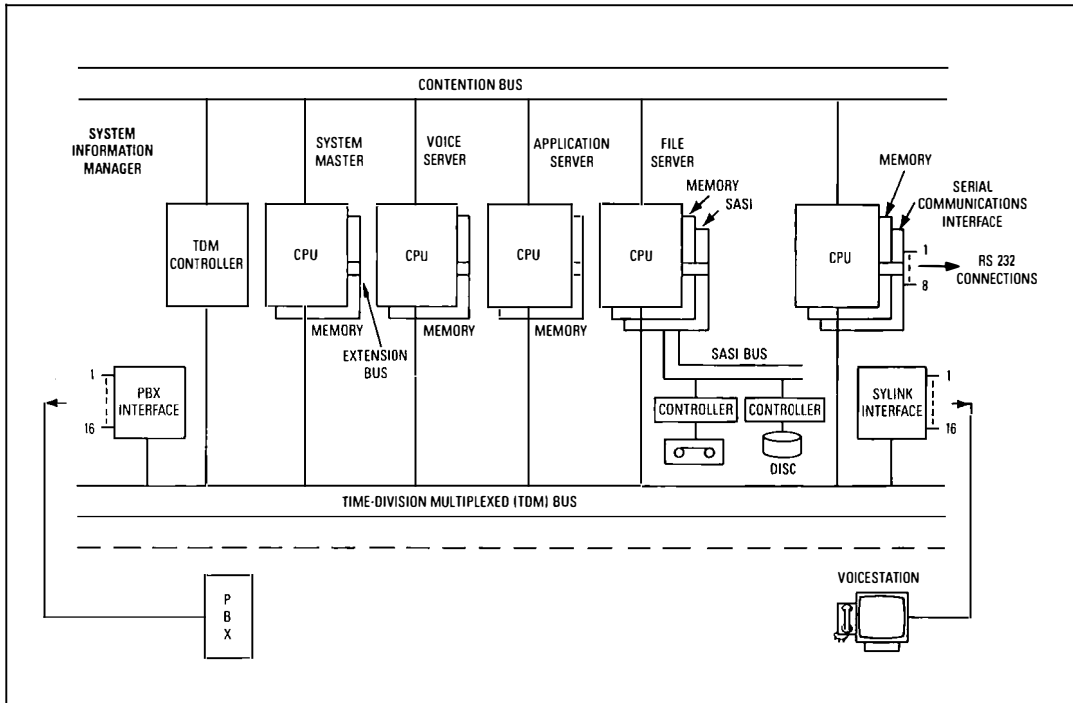

**Figure 8**  
SIM sub-assemblies

The relationships between the major sub assemblies within the SIM are shown in Figure 8. External connection to terminals and PABX lines is achieved through 50-way connectors, panel mounted, at the rear of the SIM.

Cabinets can be linked together to make a composite three-cabinet information manager.

### BUS ARCHITECTURE

The SIM uses a time-slot interleaved bus architecture consisting of a contention bus for high-speed packet transfer of data and a time-division multiplexed (TDM) bus for fixed bandwidth continuous data transfer; for example, voice coded at 64 kbit/s.

There are two physical 16 bit wide buses called *Bus A* and *Bus B*. *Bus A* is used for contention bus data and for TDM data by means of time interleaving (see Figure 9). The normally redundant *Bus B* is used to carry contention data when *Bus A* is busy and is also capable of carrying stand-by TDM data. The contention bus and TDM bus operate at a 4 MHz rate, so the maximum throughput on the combined contention bus (*A + B*) is 128 Mbit/s, and the maximum throughput on the TDM bus (*A* only) is 64 Mbit/s.

The contention bus operates as a collision sense multiple access bus. Units connected to the bus contend for access by driving a status line. The status line can be in one of three states indicating that none, one or many units are accessing the bus. If two or more units

request the bus simultaneously, a collision occurs and both units release the status line and wait a variable amount of time before requesting again.

Addressing and control of a contention bus transfer is achieved through four header words (HW0-3) associated with the transfer:

HW0 contains the address of the destination

HW1 contains the word count for the transfer

HW2 contains local command or data

HW3 contains the source address.

To ensure that no one unit holds the contention bus for an excessive time, the maximum length of a transfer is limited to 64 kbyte.

**Figure 9**  
Contention/TDM bus timing

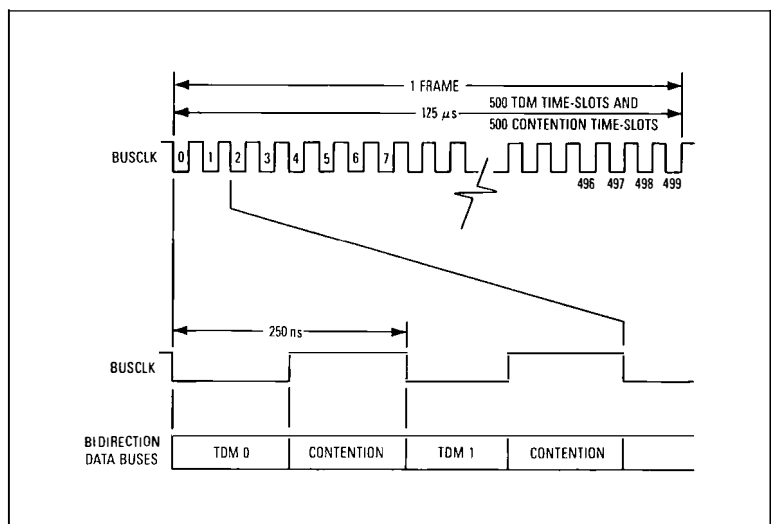



The TDM bus is organised into 125  $\mu\text{s}$  frames to support standard data transfers at a rate of 8 kHz. Each frame is divided into 500 time-slots which repeat every frame; see Figure 10. There are 34 fixed access time-slots (FATs) which are reserved for the system hardware for message passing and control functions. The remaining 466 time-slots, called *random access time-slots* (RATs), are used by the system master to create virtual circuits between any two channels in the system. Each time-slot is capable of carrying a 16 bit word. To achieve full duplex operation for 8 bit transfers, the system master arranges for one party to transmit on the high byte and receive on the low byte and the second party to transmit on the low byte and receive on the high byte.

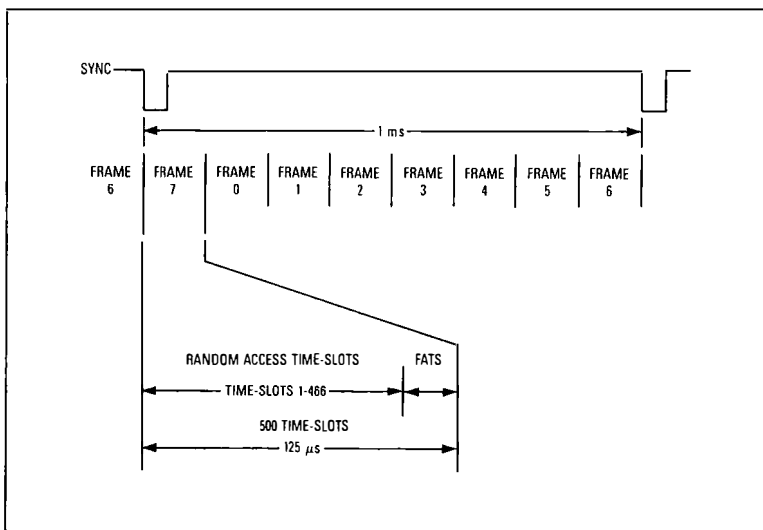

**Figure 10**  
TDM bus timing format

### CPU and Memory

Common designs of CPU and memory board are used throughout the system. These are generally used in pairs and loaded with appropriate software at system initialisation time to form the various servers needed. These are:

- System Master
- Application Server
- File Server
- Voice Server

The CPU uses a 68010 microprocessor with 8 MHz clock, with zero wait states, and uses a two-level memory management unit. The CPU is interfaced to the contention bus and the TDM bus, and there are eight programmable DMA channels supported by arbitration logic to provide a means of moving data from the TDM bus to memory.

An interface to the contention bus enables intercommunication between CPUs and the transfer of data from one CPU/memory pair to another.

A general-purpose extension bus interface is provided on the CPU to enable a third card connected to the CPU/memory pair to gain control of the memory data transfers.

Bootstrap and debug programs are provided within a 32 kbyte onboard EPROM.

The memory board is designed to support up to 8 Mbyte of dynamic RAM and is currently supplied with 6 Mbyte arranged in four banks.

The memory board receives its power from the system backplane, but all clock and interface signals come from the associated CPU through an interboard jumper connected across the front of the boards. The memory board has no direct connection with the contention and TDM buses.

The memory board is dual ported to allow for contention transfers via the CPU and provides byte parity generation and checking.

### Sylink

The sylink board provides the interface between the SIM and up to 16 VoiceStations, each connected via a 2-wire twisted pair. The data sent to and received from the line is Manchester encoded and is provided in four full-duplex 64 kbit/s channels. One of the channels is used for command and status information and the other three channels are assigned as two data channels and one voice channel, respectively. These channels can be assigned to any RAT to support 8 bit transfers.

The sylink board interfaces to the TDM bus by using a similar circuit to that used in the CPU.

### PBX Interface

The PBX interface (PBXI) provides 16 single-line analogue connections from the SIM to the associated PABX. The PBXI emulates a standard analogue 2-wire dual-tone multi-frequency (MF4) telephone.

The PBXI provides a codec per port to convert speech to 64 kbit/s PCM. An interface to the TDM bus on the PBXI enables transfer of voice information to other units in the system.

An electronic hybrid circuit is used to interface the PBXI to the 2-wire PABX connection. Networks are provided at the electronic hybrid to control terminating and balance impedances in order to meet transmission requirements for UK and non-UK telephone networks.

### TDM Controller

The TDM controller operates under the control of the system master as an interface between the PBXI and sylink and system CPUs. The controller decodes commands from the system master and decodes event information and messages being sent to the

system master from the PBXI and sylink. The TDM controller validates the clock by checking for hold faults, period variations and duty cycle variations. The TDM controller interfaces to the contention bus and TDM bus, and so is able to receive commands over the contention bus and buffer them into the correct time-slot to be received at the PBXI and sylink.

Conference bridges are provided on the TDM controller to allow three-way telephone conversation within the system.

Multi-frequency (MF4) tones are generated at the TDM controller as coded data which are sent to the PBXI where the codec converts them to analogue form for transmission to the PABX.

### File Server

A basic file server comprises a CPU, memory and a Shugart Associates Standard Interface (SASI), which provides two SASI buses. Through a disc drive controller and tape drive controller, the basic file server connects to two disc drive units (one SASI bus) and a tape drive unit (second SASI bus). A CPU/memory pair can support up to three SASI boards, each with two SASI buses.

The SASI is connected to the CPU/memory pair via the extension bus and consequently can control memory transfers. These can overlap with SASI bus transfers in order to allow for maximum SASI bus transfers of up to 1.6 Mbit/s.

Programmed I/O transfers to and from the disc controller are provided for commands and messages as well as programmed I/O data transfers for diagnostic purposes.

The disc controller can support two disc drives and has a maximum data transfer of 1.5 Mbyte/s. It communicates with the CPU via the SASI and reduces the interaction between the CPU and disc, so freeing the CPU to handle other tasks.

The tape controller co-ordinates tape-to-disc and disc-to-tape data transfers without direct CPU interaction and operates at a maximum data transfer rate of 400 kbyte/s.

### Serial Communications Interface

A serial communications interface card can be connected to an application server by means of the CPU extension bus. This creates a combined application and communications server with eight RS232 serial interface ports. A microprocessor on the interface card controls the eight independent ports which provide full duplex communication at rates up to 56 kbit/s, with separate baud rate generation per port and a digital phase-locked loop for clock recovery.

A rear-mounted adapter connects to the serial interface to provide physical cable connections to external equipment.

### Tone Register

The tone register card supports all voice manipulation programs including those for VoiceDesk and messaging. The card works in conjunction with a voice server and provides eight channels of DTMF detection used to control the VoiceDesk and messaging facility during PLAYBACK, RECORD and IDLE modes. The tone register interfaces to the TDM bus over which it receives 64 kbit/s voice data. Where this data represents long periods of silence, the system detects this and prevents such data being stored in order to minimise the size of the voice data files.

### System Oscillator

The system oscillator card plugs into the rear of the system backplane and provides: a 32 MHz clock to the backplane, synchronisation signals for the slide-in units and the capability to phase lock the entire SIM to an external clock source.

### Real-Time Clock

A paddle card providing a system-wide real-time clock and two RS232 serial communication ports can be associated with a CPU. The serial ports can be used to connect a system console to the SIM and are also valuable for off-line remote access or diagnostic testing.

### Terminator

A terminator card plugs directly into the rear of the system backplane to provide suitable termination for the buses and data lines. It also contains a system reset button which allows a controlled *system reset* signal to be generated.

### Power Supply

Each information manager cabinet contains a switched-mode power supply delivering up to 2000 W which is powered from a standard single-phase AC mains outlet. The power supply and its associated power distribution panel provide:

+5 V DC, +12 V DC, -12 V DC to the backplane  
+5 V DC, -5 V DC, +12 V DC, -12 V DC, +24 V DC to the disc and tape drives  
+5 V DC, -5 V DC to the disc and tape controllers.

A mains-powered fan tray is provided to blow air through the SIM to assist in the overall heat management.

## INFORMATION MANAGER SOFTWARE

### Mezza Operating System

The Mezza system uses a variant of the UNIX<sup>®</sup> operating system with enhancements to allow the system to accommodate multiprocessor operation and real-time processing of

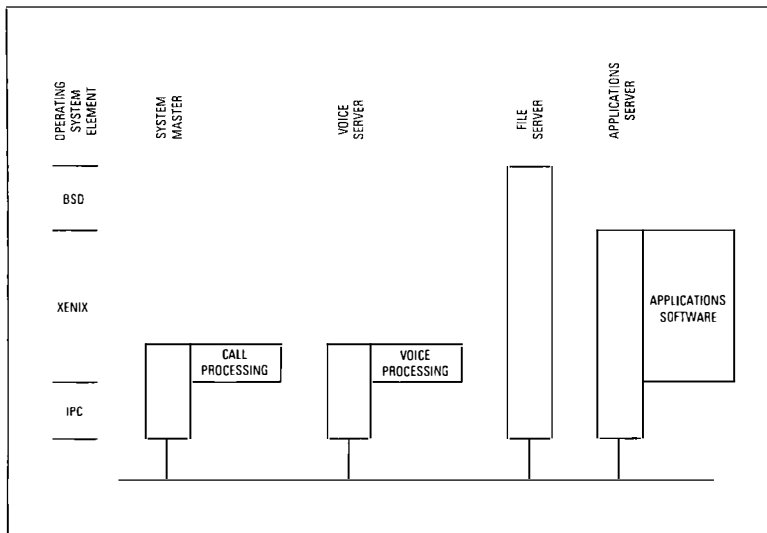

**Figure 11**  
Mezza software  
architecture

telephony and voice. The operating system is based on XENIX<sup>®</sup> enhanced by the inclusion of the Berkley Fast File System (BSD 4.2) and BT's own IPC (inter-process communication), see Figure 11. The information manager as a whole can be considered as a complete UNIX machine.

The following enhancements have been provided in the system to enhance the performance of the operating system.

To accommodate the high bandwidth necessary for the recording and playback of voice, the file system has been improved for higher performance by incorporating the Berkeley Fast File System. Instead of a single 512 byte block size used by XENIX, the Mezza operating system allocates files in blocks of 8192, 4096, 1024, or 512 bytes with optimum size chosen in each case to maximise performance and minimise fragmentation. The Mezza operating system uses a bit-map file-allocation scheme to minimise head movement.

The Mezza operating system provides a networked multiprocessor environment. The file system has been restructured to permit multiple discless application server processors to access a single unified file system. This supports the multiprocessor architecture of the SIM hardware and allows expansion without performance degradation, as the number of users and demand for resources increases. To accomplish this, file system calls from application processes are translated into network inter-process communications requests to the file server process, which processes the request on the appropriate file.

Real-time functionality is provided on the system master and voice server kernels. All time-critical software resides in interrupt routines to minimise context switching times. The servers handling real-time functionality have no user level processes running on them.

The Mezza operating system contains four different kernels, which execute independently on servers within the SIM, providing four basic server types. Each of these kernels has been optimised to suit its particular function, and they are interlinked by the IPC mechanism.

### System Master

To provide the ability to deal with time-critical processing, the system master contains only the bare nucleus of a UNIX kernel. To this nucleus is added the IPC, contention bus and virtual circuit management software. The system master manages system resources and supports call processing. System master processes control the TDM controller, and set up and manage all voice and data connections on the TDM bus.

### Voice Server

The voice server, too, contains a stripped-down kernel similar to that of the system master. The voice server executes on a dedicated processor, provides a multichannel, programmable digital voice recorder and voice services for applications running on the application server processors. All calls from the digital voice recorder to the file system are automatically mapped to the file server.

### File Server

The file server, which contains the BSD extensions, executes on dedicated processors and manages a singly-rooted hierarchical file system for the applications and tools. In addition to providing high data throughput, the file system provides multi-user file sharing, file access security, and file protection mechanisms.

### Application Server

The application server kernel is a subset of that of the file server with the addition of the VoiceStation terminal drivers. Application processors make requests to the system master, voice server and file server when system, voice or file resources are required. Application server processors run a suite of office applications including word processor, spreadsheet, mail and directory management. The application server executes on dedicated processors, managing execution of active applications and controlling the swapping of inactive ones. It does not maintain a disc cache or disc drivers. Calls from applications to the file system are mapped automatically to the file server.

### Bootmanager

The key element in system configuration is the bootmanager software. The Mezza system

configures itself on power up. The system also provides a degree of resilience by its ability to reconfigure available resource in the event of a server malfunctioning.

The monitor PROM on each CPU board tests to establish if the card is connected to a disc controller. All CPUs connected to a disc controller boot from disc and become file servers, all CPUs without a disc controller broadcast a *boot request* message. Should more than one CPU be attached to a disc controller, the processors will communicate to establish which is the primary file server. The primary file server polls the other CPUs in the system, which respond with information on their memory size and configuration. The CPU with the smallest memory is now assigned as the system master. All other nodes are then assigned according to the hardware with which they are associated.

## APPLICATIONS SOFTWARE

When all software options are included, the system contains 44 Mbyte of executable code.

All applications software is written in the 'C' programming language and is the intellectual property of British Telecom, with the exception of the word processor, spreadsheet, graphics and database applications, where source code licences have been purchased from the software vendors and the code modified to incorporate the advanced features of voice integration and Mezza's soft-key interface. The source code licences held include the Q-ONE® word processor, Informix® database, the Unicalc® spreadsheet and GSS® graphics.

The applications have been modified to access message files and soft-key identifiers indirectly, offering a language independent environment. Presentation of date format and currency displays have also been modified to reflect local variants. More than one language may be used concurrently on the system. The Mezza system supports British, American, Canadian-English and Canadian-French. Several European languages will be available in the near future.

The complete suite of software is designed to present a standard interface to the user which includes:

- An object-oriented user interface which represents different office objects pictorially.
- A basic set of functions to operate on objects.
- A user interface which supports object and function selection, as well as window management, using a mouse or numeric keys and soft keys.
- A multiwindow user interface running different applications simultaneously in different windows on the screen.
- Complete integration of telephone and voice into applications.

- Integration of applications, so that all applications use a similar user interface.

## Voice/Telephony Integration

Mezza's applications suite has the unique ability to integrate with voice and telephony.

### Mezza Voice Editor

The voice editor is a voice version of word processing. It allows the user to create, edit, store, and retrieve a voice object. Voice is available directly from the voice editor icon. It is indirectly accessible from the message slip and word processor where it annotates a message slip or a document with voice. The voice editor also supports transcription. In this application, voice is accessed from the word processor, and a footpedal allows a secretary to play back a voice document while typing into a text document.

The voice editor runs in a window (see Figure 4) on the screen which has a consistent format but various sizes, depending on the application. Within the window, it provides a graphical representation of the voice document. As the user speaks into the document, a continuous line is displayed for each second of recorded speech. When the user stops speaking, the system automatically stops recording; no pressing of buttons is necessary. If the user stops for more than half a second, the system inserts a space indicating the end of a phrase. Paragraph marks can be inserted; and paragraphs are automatically numbered.

The current position of the cursor is displayed, as measured in seconds from the beginning of the recording. The length of the recording in seconds and the mode of the editor (INSERT or OVERWRITE) is displayed in the window.

To achieve this functionality, requests for voice channels from applications running on the application servers are made to the system master. The system master controls the connection of speech channels from the VoiceStations to the voice server over the TDM bus. The voice server processes and buffers the speech, then passes the data over the contention bus to the file server. The original application links via a pointer to the voice file created.

## TELEPHONE SERVICES

In addition to providing the features of an advanced featurephone, the Mezza system is able to access telephony services from within applications. The directory application provides personal and system directories for making telephone calls and the addressing of mail. Use of the CALL soft key when accessing a directory entry will cause the directory application running on an application server to request and utilise the call processing and telephony switching functions managed by the system master. The call will be generated and

connected as if it has been dialled from the user's VoiceStation keypad.

### ADMINISTRATIVE SERVICES

Administrative services allow the system administrator, a special system user, to configure and manage a Mezza system installation. System administrative services are accessed by logging in as the system administrator and opening the VoiceStation object. The administrator is presented with a list of configuration topics, including:

- DeskTop soft key set-up
- Mail set-up
- Document set-up
- Local printer set-up
- Personal set-up
- Terminal set-up
- System printer set-up
- Timed event set-up
- Phone set-up
  - System parameters set-up
  - PABX feature access codes set-up
  - VoiceStation attributes set-up
  - PABX line attributes set-up
  - Line button attributes set-up
- System processor set-up
- System options set-up.

By using these options, the system administrator can modify the configuration database to change any of Mezza's functions, from adding or deleting users to selecting the relevant set of PABX feature codes.

### FUTURE

The Mezza system as described is installed and working in a growing number of locations at home and abroad. It represents an extremely valuable technological and marketing base from which to grow BT's commercial and engineering expertise in the information technology field. BT is utilising customer feedback to construct a long-term development plan which will gradually transform Mezza into a product line which addresses a much wider market place with relevant technology; a product line which harnesses BT's strengths to the converging worlds of information processing and communications.

The prime directions of this evolution are:

- Interworking through international standards (ISDN, OSI)
- Further integration with evolving PC products
- Improved voice functionality (speech recognition and synthesis)
- Cost reduction (through new technology)
- Improved personal communication (video-phone window option)
- Extended terminal range

- Closer coupling with PABXs.

In the short term, efforts are being concentrated on the provision of:

- An integrated PC card which replaces the VS110
- Provision of X.400 electronic mail
- A more powerful processor
- Direct linkage to a standard computer bus (VME).

At the same time, the basic functionality of the system and its terminals is being improved based on current market reaction.

In the final analysis, BT is endeavouring to provide products which fill the niche in the world of personal, departmental and corporate information processing within which BT is a natural supplier. These will be computer integrated products which are complementary to those supplied by the dominant suppliers in the computer world, providing the means to bind their products to the worlds of voice, of the PABX and the evolving telephone network.

### ACKNOWLEDGEMENTS

This article, and the Mezza system itself, owe their existence to two talented groups of people: BT's Mezza team and the engineers who originally conceived and designed the product. It is their achievement which is recorded here.

### Trademarks

UNIX® is a Trademark of AT & T Bell Laboratories. XENIX® is a Trademark of Microsoft Corporation. UNICALC® is a Trademark of Lattice Incorporated. GSS® is a Trademark of Graphic Software Systems Inc. Q-ONE® is a Trademark of Quadratron Inc. Informix® is a Trademark of Relational Database Systems Inc.

### Biographies

Rob Walters joined the BPO in 1963 as an apprentice in a Telephone Area. Since graduating, he has worked within the Research Department on System X processor performance, the design of the Monarch PABX and telephone transmission. He has spent the last few years introducing convergent products to BT and is currently the Head of Development within IPD's Computer Integrated Telephony Group.

George Roxburgh joined BT in 1971 and has worked in a number of development departments on a range of telephone products and the highly successful Monarch PABX development. He is currently the System Hardware Development Manager for the Computer Integrated Telephony Group in BT International Products Division.

Dave Newey joined British Telecom in 1981. He has worked on the product development of telephony switching products. He is currently the Mezza system architect working within the computer integrated telephony group.

# Rural Telecommunications in a Third World Country

E. J. WELSH, B.A., C.ENG., M.I.E.E.†, and D. DECRUZ, B.SC., C.ENG., M.I.E.E.\*

UDC 621.39

*This article looks at the telecommunications infrastructure of a typical West African country and highlights the problems that have to be overcome, particularly in the rural areas, just to meet the United Nations' objective of ensuring that everyone is within easy access of a telephone within one hours walk. The article is based on a study carried out in Sierra Leone by British Telconsult and presented as a paper at the Institution of Electrical Engineers Conference on Rural Communications, May 1988, and is reproduced here by kind permission of the IEE.*

## INTRODUCTION

Although traditionally the term 'rural' is used in conjunction with anything to do with the countryside, the CCITT defines rural telecommunications as 'communications in a rural zone'. A 'rural zone' exhibits one or more of the following characteristics[1]:

- (a) scarcity of primary power, or uncoordinated scattered power generation;
- (b) scarcity of locally-available qualified technical personnel;
- (c) topographical conditions (for example, lake, desert, snow-covered or mountainous areas) which are obstacles to the construction of conventional lines and transmission systems;
- (d) in some zones, tropical, semi-tropical or other severe climatic conditions that make critical demands on the life and maintenance of equipment; and
- (e) economic constraints on amortising investments.

Sub-Sahara Africa certainly has the above characteristics: all except perhaps snow!

Africa is the most underdeveloped continent in the world as far as telecommunication facilities are concerned. In 1983, there were only 1.53 subscriber sets per 100 inhabitants for the whole continent of Africa compared with 35.47 in the Americas and 30.86 in Europe. Most African countries are well below these figures. Ethiopia, for example, has 0.23, but Nigeria only 0.08 [2]. However, it is the United Nations' declared intention of ensuring that everyone on the globe is within easy access of a telephone by the turn of the century, and this has been defined as within an hours walk. This article looks at the problems encountered in a typical West African country and concludes that this intention will be very difficult if not impossible to achieve.

The main aim of the article is to bring the reader down to earth by outlining the very real day-to-day problems faced by telecommunication administrations of emerging nations. This article looks at one particular country, Sierra Leone, where British Telconsult‡ has built up experience over at least 5 years. Telconsult has also recently been awarded a contract for on-going supervision of the implementation of some of the recommendations of the earlier work.

## SIERRA LEONE—A Background

The Republic of Sierra Leone is an independent West African single-party democracy, whose main language is Krio, a variant of English. It is about the size of Scotland, some 72 000 km<sup>2</sup> in area. Although the land includes coastal swamps, it is generally agriculturally rich.

The country lies in the south west of West Africa in the tropical zone some eight to ten degrees north of the equator. It has distinct wet and dry seasons: the monsoons, lasting

Figure 1  
Mesh National Network

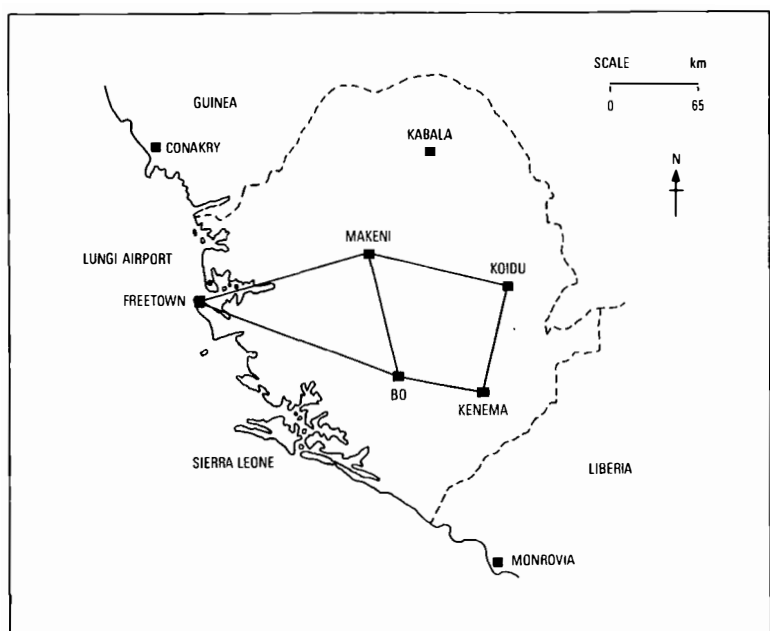

† British Telecom International Products Division  
\* British Telecom Overseas Division  
‡ British Telconsult is part of British Telecom Overseas Division  
© 1988: Institution of Electrical Engineers

for some four months, are accompanied by particularly violent electric storms.

Sierra Leone has a population of approximately four million, but has only 14 600 telephones. Of these, 12 000 are in the capital, Freetown, with most of the remainder (1850) in the large towns of Bo, Kenema, Makeni and Koidu. However, 75% of the population live in rural communities and are dependent on the land for their livelihood. In terms of telephone sets per head, there are less than 0.37 per 100 compared with a figure of 80 per 100 in the USA. But as will be seen later, this figure has no real meaning, particularly in the provinces.

The country's chief products for foreign exchange are diamonds and other minerals, cocoa, and coffee. The main diamond area is in the North East some 200 km from Freetown. The efficiency of this business is hampered by poor communications to Freetown and hence the rest of the world. Messages between the up-country site and Freetown are sent either via a SSB HF internal radio system or even by car. Those with the rest of the world have to be re-transmitted in Freetown.

#### **FINANCE FOR TELECOMMUNICATIONS**

Any government with limited foreign currency has to play a careful balancing game with the demand for foreign goods. Aid agencies play a big part in helping such countries to develop. Money can be obtained from various sources such as the World Bank IMF (International Monetary Fund), ECOWAS (Economic Community of West African States), the United Nations Development Programme and especially its subsidiaries the ITU and ILO; the EEC (European Economic Community) and other countries' specific aid agencies such as the British ODA (Overseas Development Administration).

The EEC is particularly active in Sierra Leone granting soft loan funding and grants for agricultural projects in the North and a continuing telecommunications project.

#### **TELECOMMUNICATIONS IN SIERRA LEONE**

In 1982, British Telconsult was invited by the Sierra Leone Government to undertake a study of the Telecommunication Administration's facilities and to report on how these could be improved.

The following picture emerged from this initial work:

- (a) the condition of the network was such that service was well below an acceptable standard;
- (b) the lack of fuel and foreign exchange had exacerbated this problem;
- (c) the financial returns were diminishing and even becoming negative;
- (d) the exact extent of the loss was difficult

to determine because the department was combined with Posts and all money went into the central Government Treasury;

(e) staff morale was low and training programmes were not tailored to the requirements of the company; and

(f) there was lack of any basic management statistics. There were none of the administration monitors, checks or controls that are necessary for the assessment of a system's financial and service performance.

Despite a lack of statistics, visits to towns and discussions with the Ministry of Development and Economic Planning and other bodies soon revealed the growth potential for telecommunication. Current usage and busy hour were also estimated, by manual means. The major point to emerge was the suppressed traffic demand. From this work, short-, medium- and long-term plans for development were prepared.

The following key requirements were identified: a new Freetown central exchange; spare parts for the existing exchanges, for vehicles, for the radio systems, for generators; and for air conditioners, junction and external plant cables, batteries, frequency monitoring equipment, staff training ...; in fact the whole infrastructure for telecommunications.

In 1986, British Telconsult was awarded a further contract to prepare tenders and assess responses for the first phase of the planned improvement. This gave a further opportunity to reassess the original recommendations, particularly as three years had elapsed. This article reviews some of the recommendations from this 1986 review.

#### **State of the Organisation and Financial Background**

Early in its consultancy role, British Telconsult examined the operations of the Sierra Leone Posts and Telecommunications Department and its relationship with other Government Departments. It was concluded that the methods of financing and controlling the telecommunications services were both inadequate and inappropriate. There were a lot of bad debts. However, effective solutions such as withdrawal of service were not being carried out. At one stage, it was found that telephone bills, already late, were not being sent due to the unavailability of paper.

To instil the necessary commercial drive and profit awareness, with an effective management and organisational infrastructure, and an efficient service, it was deemed desirable to allow telecommunication activities greater freedom from direct government control. In the process of achieving this, a separation of the Post and Telecommunications Department (SLPTD) took place with the formation of the Sierra Leone National Telecommunications Company (SLNTC) in January 1987, fully owned by the Government.



To improve the operational infrastructure of the company in a commercial environment, technical assistance was made available through secondment of an expatriate Managing Director from British Telconsult. Other consultants from British Telconsult were employed to work in more detail in:

- (a) financial administration;
- (b) management structure; and
- (c) external plant records.

Senior company counterparts were to be trained to reorganise the billing, revenue and tariff arrangements of the company and to draw up accounting and audit procedures leading to the publication of the first set of official accounts. In addition, the management structure of the company was revised and job descriptions were prepared to enable recruitment of suitably-qualified permanent staff.

### Equipment Systems: Problems, Solutions and Recommendations

#### Power systems

The chief source of mains power in Sierra Leone is diesel generation. The heavy rainy season does permit some hydro power generation; in the east of the country a new Chinese system has come on stream only within the last year. A proposal for a similar system in the north has awaited financial backing for over 5 years.

There is only a limited local grid. 1979 saw a very serious fuel crisis in the world when prices rocketed. In Africa, with the exception of oil-producing countries, people could not afford to pay, and large cuts resulted. The country is still recovering from the effects of this crisis.

Only a few of the telephone repeater stations on the national network are fed by mains power. The chief source of power for the majority of sites is closed-circuit vapour turbogeneration (CCVT). Secondary back-up systems in both cases are diesel generators. CCVT systems work as follows: the vapour generator is a sealed system containing an organic liquid (at below atmospheric pressure for safety). Fuel (kerosene) is burnt and the heat vaporises some of the liquid. The expanding vapour causes a turbine wheel to rotate driving a directly coupled alternator. The vapour is cooled by an air condenser and re-cycled. A solenoid valve which controls the fuel operates from voltage trips. This is a fairly reliable system when run continuously and requires minimal maintenance (just fuel jets cleaned every 6 months). The fuel efficiency is however very poor, requiring four times as much fuel as diesel generation. In 1983, the SLPTD was getting less than half of the fuel it required. The probability that all sites on a route had fuel was getting lower

and lower. Closure of some routes to allow others to run was inevitable.

Whilst Sierra Leone does suffer from severe lack of fuel, sunshine is plentiful and solar panels offer an ideal alternative for low-power systems; for example, radio relay. The capital cost of this type of system using photovoltaic cells is relatively high. Although CCVT and solar panels on a cost analysis alone are nearly equivalent (see Table 1[4]), in a country without fuel, solar panels are bound to be preferred. The other advantage of solar power generators is that minimum low-technology maintenance is required; basically all that is required is just washing and battery topping-up. As solar panels produce a DC output, there is no need for rectification and hence a potential fault liability is removed.

**TABLE 1**  
**Comparative Costs of Power Systems**

	Capital Depreciation	Fuel and Maintenance	Total (\$/kWh)
Diesel-Powered Generator	0.65	0.87	1.52
CCVT	2.91	2.94	5.85
Solar Power	4.43	0.23	4.66

World prices for solar panels continue to drop significantly. Solar generation has been recommended for introduction at a number of repeater sites, preferably on entire routes, for reliability.

#### Switching Systems

The automatic switching equipment is based on an electromechanical rotary system. There are 15 exchanges of this type, most being in Freetown. The oldest is the central trunk local exchange, Freetown Central, which was installed in 1965. The existing automatic exchanges use a system of single fee on connection for local calls. Whilst this can be considered a reliable simple system, companies can, in effect, set up their own private wires between their offices for a few cents. The result has been junction/call blocking and minimal revenue. There are a number of manual boards throughout the country typically dimensioned 10+50. A number of new manual boards were being installed in 1983 as part of an extension to the network.

The automatic switching systems suffer from a lack of maintenance. Spare parts can be acquired only from Europe with foreign currency, although local maintenance staff do try to keep exchanges functioning when power

is available. Wrong numbers are common due to equipment malfunctions. It is remarkable that this equipment has withstood the climatic conditions. Air conditioners are often not working, power is regularly off, battery voltages are low and lightning strikes during the rainy season are frequent and severe. With the high proportion of overhead wires, exchange lightning protection is important.

A number of solutions to these problems can be considered. These are:

- (a) continue with old systems such as Strowger or rotary,
- (b) introduce an intermediate technology (for example, common-control reed-relay systems),
- (c) introduce digital switching, and
- (d) continue with PMBXs.

The advantage with the first two items is that as these systems are being withdrawn from service in the Western World, second-hand cost may be low. However, SLNTC did not favour perpetuation of intermediate switching technology from overseas for expansion as they wished to ensure that equipment and spares would be available at a reasonable cost.

Although a gift of equipment using both Strowger and an intermediate technology were offered by an European operator, this is still under consideration. At first sight, one might question why this was not snapped up, but it must be realised that staff would need to be specially trained overseas, the equipment would need to be reconfigured, interfaces would need development, different technologies would be introduced, and maintenance spares (that might not be available in a few years) would be needed.

Freetown Central is a very important hub with a good potential for growth. Digital links from abroad already link the Freetown International Exchange† with the world's digital networks. With the markedly better power supply in the Freetown area than in the provinces and the demand and growth requirements to be met in the existing available exchange accommodation, recommendations advocating a digital exchange were well received.

With the local training and remote technical support offered by overseas contractors, the simplified replacement of faulty units for maintenance, and reliable environmental conditions for digital exchanges, only serious software problems would normally require the presence of specialist overseas experts. Faults on digital systems are typically only diagnosed down to a card for about 80% of the system and hence provision of a system expert has been included in Telconsult's recommen-

---

† The international exchange is operated by a private company and its operations are not covered in this article.

dations. Part of his task will be to ensure that the training is being effectively applied. Also, an extra long warranty period and provision of adequate spare units will help buffer the company from the eventual problems inevitable in taking this on. The possibility of provision of a local repair facility for commonly used cards (for example, line units) was asked for in the tender.

The reliability of power supply is to be catered for by dual stand-by diesel generating sets. With the provision of PCM junction routes to satellite exchanges, remote concentrator exchanges become a possibility, and a strategy for expansion of the local units by digital growth would mean that interworking equipment would have a more economic life.

In the short term, the existing Freetown Central equipment needs to be maintained. A number of spare parts ranging from selector oil and lamps to relays and transformers are to be acquired as part of the refurbishment plan. Servicing of the DC and AC motors is also included. Growth at the provincial automatic exchanges is to be catered for by equipment recovered from Freetown. This will be installed by local staff with assistance from expatriate engineers experienced in the existing types of system. This team of overseas and local staff will also install local call timing equipment.

### *National Network*

The main network of Sierra Leone is of microwave radio-relay equipment. This comprises a PanAftel link, which included links to neighbouring Liberia and Guinea, installed in 1980, together with some much older equipment. A new 'northern route' was being commissioned when the survey was done in 1983. This gave a network in the form of a mesh for security. This equipment provides an analogue 960 circuit channel, allowing occasional TV on the protection channel. A number of repeater sites provided drop and insert facilities; with the large channel capacity and low traffic requirement, this can easily be done by filtering techniques. From this network a number of spurs of VHF equipment radiate.

The town of Kabala in the north is not served, even though it is a district headquarters. Telephone service used to exist here many years ago. The short-term plan included providing service to this important town and thereby reopening this area to telecommunications.

Radio offers a cost-effective solution to penetrating into the hinterlands. The main option is whether to convert to digital or retain analogue systems. The provision of systems that allow occasional TV use needs questioning. The existing systems in Sierra Leone have never been used for TV: without the need for TV, much more cost-effective low-channel

systems can be provided. Provision of 60 circuits is often generous and to have 960 circuit systems just to provide a TV capability could be viewed as expensive overprovision.

In 1986, three years after the original survey, it was found that the national network had virtually collapsed. The new northern route had been abandoned in a partially commissioned state due to lack of foreign currency. Much of the old equipment had not been working for some time and was now obsolete. Only one route operated to Bo and, occasionally, to Kenema. This had deteriorated to a single system with no stand-by. It was obviously pointless extending a network that did not exist! A detailed survey was necessary, and the EEC agreed to fund a detailed survey of existing routes.

The Government and SLNTC supported a British Telconsult recommendation that tenders were not sought at this stage for the extension to Kabala as had been suggested three years previously.

The detailed survey reported in 1987, and its main findings were that:

(a) The radio equipment could be economically refurbished.

(b) Batteries had to be entirely replaced. In order to retain service as long as possible, low voltage relay trips had been made inoperable and this had aided the decline of the batteries.

(c) Lack of basic building maintenance contributed significantly to deterioration of equipment. For example, a major repeater node had a leaking roof which had resulted in damaged equipment. Vermin (rats, termites and wasps) had made nests in the equipment. The rats had chewed ribbon cables and entire back wiring forms needed to be replaced. The insulation had been chewed from rectifier cables making them dangerous to power up.

(d) Digital replacement would cost about five times as much as the refurbishment. The hop lengths are such that noise figures may well require additional repeaters which would add substantially to the estimate.

What has been recommended is a very much cut down single 'trunk' system (not the previous mesh) from which branches can regrow and ultimately the mesh can be reformed. The routing of this was chosen via good new accessible roads for ease of maintenance.

#### *External Plant: Local and Junction*

During surveys by British Telconsult, the external plant network was found to be in a very poor state of disrepair, with an absence of plant records and statistics. Primary and secondary cables are directly buried rather than ducted and hence are prone to damage. Incorrect installation of overhead cables, with many mid span joints, was also found and

many of these cables had suffered lightning damage. There was also a shortage of cable and some other external plant stores essential for maintenance and fault correction. Because of the high occurrence of lightning, aerial cable runs need to be minimised. In more remote areas, subscribers access radio does offer an alternative solution for connecting diverse communities to a distant exchange. For the junction cables in the Freetown area, PCM links are needed to enable remote concentrator units to be provided. As this was to be provided by European firms, the European standard of 30 channels was decided upon.

A number of short-term recommendations were made to improve this situation, but without the essential infrastructure, funding, planning and provision of stores, the problems are only more recently being addressed. Because of the lack of knowledge of the state of the external network, a 'tap out' and test was undertaken; it was soon established that the junction network of armoured lead-sheathed quad-type paper core cables could not support digital transmission. The 'tap out' exercise itself had to be curtailed due to a fuel shortage in the country. Transverse screen cable has been recommended as more appropriate than optical fibre for the 30-channel PCM junction transmission system linking the satellite exchanges with the new digital Freetown central exchange. The main reasons for this were the skills readily available and the expense of the tools necessary to joint optical fibre.

Subscribers access radio was advocated to give service to the south east. This would not be economical, but would effectively introduce a small number of channels into diverse communities. Regrettably, this part of the medium-term plan has been curtailed to ensure that adequate funds are available for the rest of the programme. However, a project in the islands with the backing of a UK University is providing interesting results[5].

#### *Maintenance Backup*

To provide effective maintenance, the following prerequisites must be available:

- (a) trained staff,
- (b) test equipment,
- (c) a programme of preventative maintenance,
- (d) operational vehicles,
- (e) fuel, and
- (f) repair facilities for kit, such as solder and soldering irons.

Little of this exists and virtually all require foreign exchange. One of the crucial items again is fuel.

Good service routines and test equipment were left by the equipment manufacturers, but faced with the lack of parts to carry these routines out, the senior engineers on both

telecommunications equipment and vehicle maintenance were forced into a 'fire fighting' exercise, only repairing broken down equipment. When replacement parts were identified, a long procedure was necessary for authorisation. If even a basic item such as solder is missing how can staff be expected to maintain any service?

To ensure that the new company can effectively maintain its network, training packages are to be included with all new equipment supply contracts. Retraining on the existing equipment will also be carried out in Sierra Leone to ensure that the appropriate technicians are trained. This will be supplemented by technical assistance from abroad. Adequate spare parts are to be made available. The necessary company infra-structure will be created, with adequate funds to ensure that new parts are ordered when necessary. Also included in the package is a complete range of telecommunication vehicles and engine maintenance tools and test equipment.

#### *Telephones and Coinboxes*

Yet again, lack of foreign exchange has meant that there are no maintenance spares or new equipment available in Sierra Leone. Service can only be provided to new customers who have equipment and lines; this has resulted in some telephones disappearing from government offices and expatriates have collected telephones from abroad on their home leave. Those attempting to provide their own replacements or extensions have problems because local telephone wiring is not necessarily the same as that in foreign countries.

All that is required in most country areas is a public payphone; the majority of the population could not afford the rental of a private telephone. Although they would prefer a coin-box, because of the fluctuation of the currency some sort of unit-credit cardphone is preferable. This would also eliminate the need to empty the boxes as this could cost more than the coins collected.

Telephones and card pay-phones are proposed to be included, together with the new exchange purchase. Also some secure method of revalidating the credit on these cards is to be arranged.

#### **ASSESSMENT OF THIRD WORLD PROBLEMS**

Although Sierra Leone has been used as an example, their problems are by no means unique. Other Sub-Saharan African countries suffer similar if not worse problems. In Sierra Leone, assistance is welcomed and the administration is very keen to help with improvements. To meet telecommunications requirements, developing countries need:

- foreign currency
- trained staff
- low capacity systems
- minimum power systems
- low maintenance, not specialised
- equipment ruggedized against severe climatic conditions
- locally available parts for local currency
- locally available power sources
- good management infra-structure.

What does aid from developed countries offer? How does one answer the (African) criticism that self-interest of developed countries in perpetuating their standard of living lies behind most foreign aid agencies? In order genuinely to help the developing countries, there is a need to look more closely at what they really need. Yes, they need expert assistance to help, but what happens when the expatriate leaves? Does the system left start to crumble again until the next bit of aid arrives, possibly from somewhere else with different views? Continuity of help with training does answer some questions and this has formed part of this project. Wherever possible local staff have been used to complement overseas expert assistance.

The authors believe that management training, not necessarily in European styles, but geared specifically to motivating African workforces, is what is required. In addition, encouragement needs to be given to local industry. If all damaged equipment could be repaired locally, it would save valuable foreign currency: this facility could be expanded to earn hard currency or even help other fellow countries. Should all aid have a 10 or 20% figure for this included? The authors believe that aid from donor countries should increasingly be aimed at indigenous manufacture and the support of new technologies.

Is the technology necessarily correct? It must be remembered that most modern systems have been designed for our own requirements and climatic conditions. What research is being done to confirm that our technology is appropriate for developing countries?

#### **CONCLUSIONS**

Europe has its problems which are not the same as in Africa. Labour here is very expensive and automation is our solution. Automation leads to a preference for mass markets and not at meeting specialised needs with correspondingly small profits. In Africa, labour is comparatively very cheap and it may be that a 10+50 PMBX is a cost effective solution in certain cases. Africa's problems cannot just ride on the West's technology. Optical fibres offer tremendous bandwidth, but the need for this bandwidth in Africa is most unlikely. They have their own unique problems which need solving. From paper for telephone bills, fuel for vehicles and power generation to optical-fibre transmitters, none

are available without costly hard currency. Their problems can almost be divorced from our latest technology.

The authors believe the ultimate solution must lie with the United Nations Council who set the original aim. They can be the only body to ensure that the necessary funding of an infrastructure for indigenous manufacture is in place, but Western telecommunications industries and technical institutions must be behind such a move. Only then can the problems of Sub-Saharan Africa be effectively answered.

## ACKNOWLEDGEMENTS

The authors are indebted to the Government of Sierra Leone and to the newly formed Sierra Leone National Telecommunications Company (SLNTC) for permission to publish the information. Our thanks go to the Commission of the European Community without whose funds this project would not have been possible and to the Director of British Telecommunications Overseas Division for permission to publish this paper. We must not overlook our colleagues in British Telconsult who have contributed significantly to this project and other colleagues for their criticisms. The opinions expressed are the authors and do not necessarily represent the views of the management of British Telecommunications plc or its subsidiaries. This article is based on a paper presented to the IEE Rural Telecommunication Conference in May 1988 and the authors thank the Institution of Electrical Engineers for permission to publish.

## References

- 1 CCITT Rural Telecommunications. ITU GAS 3 Publication, Geneva, 1979.
- 2 UHLIG, E. Rural Communication: Switching and Transmission Systems for Emerging Nations. *Telecommunications*, Oct. 1986.
- 3 CCITT Economic and technical aspects of choice of transmission systems. ITU GAS 3 Publication, Geneva.
- 4 CCITT Economic and technical aspects of choice of power systems. ITU GAS 4 Publication, Geneva.
- 5 CHANDLER, S. A. G., and KARIMU, S. Sierra Leone Low Cost Rural Telecommunications Project. IEE International Conference on Rural Telecommunications, May 1988.

## Biographies

John Welsh is currently International Standards Liaison Manager in the Business Development Unit of BT's International Products Division. He joined BT as a trainee technician apprentice in Thamesway District in 1965. He was promoted into UKC/TNP on microwave planning. He decided to take a degree, initially on his own but was later awarded a BT scholarship. He graduated from the University of Essex with an upper second degree in Telecommunications Engineering and promoted to level two. John has had a particularly varied career taking him from tropospheric scatter provision to the oil rigs off Shetland with BTI, to radio planning in Nigeria with secondment to the ITU. He was a member of the BTOD project team which went to Sierra Leone in 1986 and returned the following year as Senior Transmission Advisor. Over the last ten years he has been involved in digital switching research and development particularly System X. He was responsible for the CEDRIC RCU commissioning tester used by district staff. His current role is to ensure that IPD products are legally and technically marketable throughout the world acting as a liaison point for world standards requirements. He has also recently been awarded another BT scholarship to study for an MBA degree at Henley Management College which will be done in his own time by distant learning.

Don deCruz is currently Projects Manager with BT Overseas Division on the Sierra Leone Project, financed by the EEC and involving network studies, specification of requirements, tendering, contract evaluation and award. He joined BT in 1963 with an honours degree in electrical engineering and was appointed to the Dollis Hill Research station, where he was engaged on digital switching, active filter projects and developed the register/translator for the Empress Digital Tandem Switching Development. His subsequent career has been varied with several years on reed-relay switching, the TXE6 group selector, the development and implementation of the TXE4/4A family of large local exchanges. He served on the UK Trunk Task Force and was responsible for the utilisation of a suite of computer programmes to define the optimum digital switching and transmission network and also contributed to specialised studies on joint PO/industry fora—the Advisory Group on System Definition. Don's responsibilities included the development of signalling cards for 24/30-channel PCM applications to CEPT/CCITT standards, before being seconded to the United Nations Development Programme (UNDP) as a consultant with the ITU in the Middle East where as Project Manager he was responsible for identifying training projects for a Telecommunications Institute, computer and digital switching applications. His appointments have also included technical consultancy with BT finance functions involving auditing of network strategy options to verify and report to Senior Management on data utilisation, financial/technical principles and recommendations.

# Using CEDRIC to Commission System X Concentrators

R. A. STARTIN, B.A., PH.D., C.ENG., M.I.E.E.†, R. F. BOOTH, B.SC.\*, B. B. TRAWFORD, B.SC., C.ENG., M.I.E.E.†, J. C. DENNY, B.SC.†, and J. BARNES, B.SC.†

UDC 621.395.345

Since March 1986, British Telecom has been installing about half of its System X remote concentrator units by direct labour, rather than by contractors. It is vital to check that concentrators are fully operational before they are connected to the parent local exchange. A tool called CEDRIC was developed in order to do this commissioning task. CEDRIC evolved continuously as the concentrator design was enhanced, and as feedback was obtained from the District installation teams. This article illustrates the scope of commissioning by direct labour, and describes the final version of CEDRIC.

## INTRODUCTION

A System X local exchange [1] consists of a common core and a number of concentrators. These concentrator units [2, 3] connect customer lines to the core and actually account for the bulk of the exchange equipment.

Each unit serves up to 2048 customers and concentrates the traffic and the signalling messages onto between two and eight 2 Mbit/s paths for connection to the route switch in the parent exchange (see Figure 1). The route switch steers the signalling messages to the central processor, and it is under the control of this processor that the traffic is switched to either the appropriate concentrator (the originating concentrator in the case of an own-concentrator call) or another exchange.

Concentrators can be co-located with the central processor and the route switch, or they can be accommodated some distance away. In the latter case they are called *remote concentrator units* (RCUs).

Modernisation of the network is a massive task, and it is operationally convenient to regard the installation and commissioning of concentrators as a self-contained job. Although the equipment will have been tested before leaving the supplier's factory, there is a risk that, when the concentrator has been installed, it will not work properly. There may have been damage in transit, for example, or errors in the cabling. It is vital that any such faults are found and corrected before the concentrator is connected up to the route switch and goes 'live'.

Where the installation is done by British Telecom staff as a 'direct-labour' job, a specially-designed tool called *CEDRIC* is used for the commissioning. (*CEDRIC* stands for Computerised Equipment for Direct-labour RCU Installation Commissioning). Up to July 1988, when the final version of *CEDRIC* was made available to the Districts, over 700 concentrators on 450 sites had been commissioned using *CEDRIC*.

The initial version of the concentrator and all subsequent upgrades—designated *SEP1 LE/1*, *SEP1 LE/2* and *SEP2*—have been commissioned using *CEDRIC*. Current plans are for direct-labour commissioning to continue at a similar level for the next two to three years. Under certain circumstances, *CEDRIC* is also being used for re-commissioning concentrators that are upgraded from *SEP 1* to *SEP 2*, and for validating concentrators that were installed by contractors but have been powered down for a substantial period before connection to the parent exchange.

## OBJECTIVES OF THE CEDRIC PROJECT

The objectives of the *CEDRIC* project were to provide equipment and procedures such that:

- (a) District technical staff could commission the installed concentrator without requiring excessive training;
- (b) wherever possible, the equipment required by *CEDRIC* would be already avail-

Figure 1  
Use of concentrators in a System X local exchange

† Research and Technology, British Telecom Engineering and Procurement  
\* Network Operations Support, British Telecom UK Communications

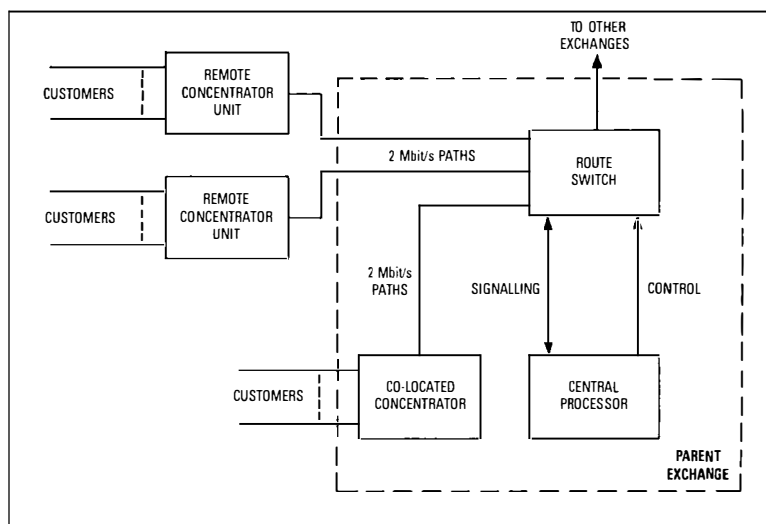

able to the District, and any additional purpose-built equipment would be robust and transportable;

(c) for the first version of the concentrator and its subsequent upgrades, there would be an appropriate version of CEDRIC available to the District when required;

(d) as much of the concentrator would be exercised during the commissioning as possible;

(e) when a fault was found, sufficient guidance would be given on its location to enable it to be rectified; and

(f) on completion of commissioning, a printed record showing the operation of all the tests would be available.

## DESIGN PHILOSOPHY

The concentrator has a duplicated processor called the *module controller*, which hosts some powerful software (see Figure 2). When triggered by suitable signalling messages from the central processor in the parent exchange, this software provides a high proportion of the routing and diagnostic functions available within the concentrator.

CEDRIC simulates these interactions with the central processor, so that the concentrator can be made to exercise almost every part of its hardware.

For customer line tests, the concentrator is run in 'isolation' mode. This mode is used in service only under exceptional circumstances, but it is useful when commissioning as it enables own-concentrator calls to be made internally without involving the route switch in the parent exchange.

The interactions between CEDRIC and the module controller are similar to those that would be prompted by a maintenance engineer

working at the operations and maintenance centre (OMC) [4]. However, the opportunity has been taken to automate the usual man-machine interface interactions to save test engineers' time.

The required interactions are held as automated test sequences, or 'test files'. It is the use of these, together with the features already integral to the concentrator software, that are fundamental to the CEDRIC design.

In SEP1 concentrators, the module controller software is held in ROM. When a concentrator is brought into service, its hardware configuration data is downloaded into the module controller RAM from the parent exchange. This data quantifies the hardware 'resources' [5]; that is, the hardware components of the concentrator as defined for maintenance purposes. CEDRIC has to perform an equivalent download before commissioning can start. It is also necessary to be able to alter the resource configuration later on as the testing progresses.

For SEP2 concentrators, the module controller software is not stored in ROM; it has to be downloaded into RAM from the parent exchange. For commissioning purposes, CEDRIC must be able to do the same thing. In practice, this is not the first step in the procedure, since the concentrator may have a fault that prevents the download being successful. SEP2 concentrators therefore have some of their RAM cards temporarily replaced with ROM cards for the initial stage of commissioning.

To give the test engineer a high degree of confidence in the test results, all test files were originally written assuming a 'cold start'; that is, the concentrator resources were set into a known state before each test was run. However, feedback from use in the field proved

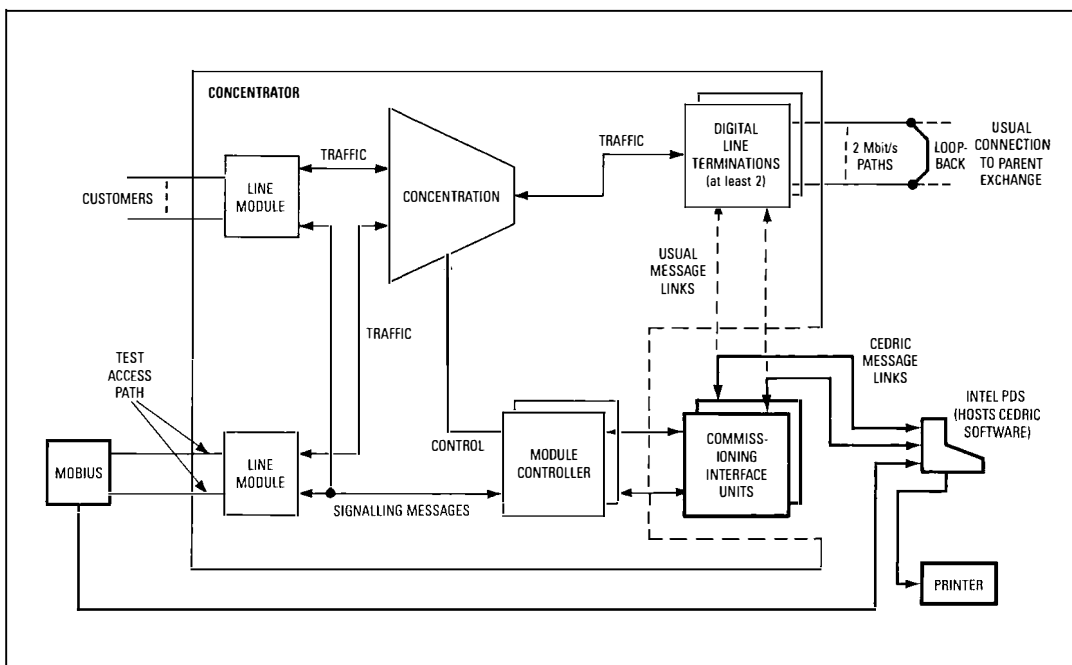

**Figure 2**  
Use of CEDRIC to commission a concentrator (CEDRIC items shown in heavy outline)



that this approach was over-cautious. Later builds of CEDRIC allow test engineers to run test files without having to reset the resources, thereby speeding up commissioning considerably.

### EQUIPMENT USED

The CEDRIC equipment comprises hardware and software modules that enable a concentrator to be commissioned without the need to connect to a parent exchange or subscribers' lines. The interconnection is shown in Figure 2, and the individual modules are described below.

The equipment comprises the following main modules:

- Intel PDS computer and printer,
- software,
- commissioning interface units (CIUs), and
- MOBIUS universal exchange tester.

### Intel PDS Computer

The CEDRIC equipment is based on an Intel PDS 100 computer with integral VDU, keyboard and single disc drive (see Figure 3). Two PDS 351 units are installed to provide two more RS232 ports. An additional external double-sided, double-density, 5.25 inch floppy disc drive unit is also included. A dot matrix printer is provided for hard copy output of test results.

### Software

The CEDRIC software comprises a suite of programs and data which run on the PDS. It is the most important part of CEDRIC. The structure of the software and its functions are

outlined in the next section. The three main parts, and the way they interrelate with the user, the concentrator and each other, are described in some detail in the three subsequent sections.

The software is held on three floppy discs.

### Commissioning Interface Unit (CIU)

The CIU provides an interface between the PDS and the concentrator under test. It is a single-width slide-in unit and compatible with the System X equipment practice. Two CIUs are required, one associated with each module controller.

The CIUs replace the message transmission subsystem (MTS) remote terminal units (RTUs) [6] during commissioning and allow access to the microprocessor shared memory interface on the module controller. Communication between the software in the PDS and the CIUs is handled by two independent asynchronous RS232 serial links.

### MOBIUS Call Sender

A MOBIUS universal exchange tester is provided to act as a telephone emulator. It is used to commission the analogue subscriber lines on the concentrator, under the control of CEDRIC. In the course of a typical test, it automatically calls on one line and answers on another, sends and receives tones, and checks transmission levels.

Certain tests require facilities that are not provided by MOBIUS, so several additional test telephones are required. These are provided as part of the test engineer's CEDRIC kit.

### SOFTWARE STRUCTURE

The CEDRIC software is split into three main parts:

- PDS control software,
- CEDRIC applications software, and
- module controller software.

### PDS Control Software

The PDS control software (ISIS operating system) is proprietary software from Intel which provides the basic user interface for the PDS, especially in the area of file handling. It also provides input/output (I/O) facilities for user programs, enabling control of the printer and disc access ports. Overall, it affords an environment for running user programs. This software is loaded into memory from floppy disc at 'boot up' to allow immediate operation.

### CEDRIC Applications Software

The CEDRIC applications software is crucial to the commissioning process. Its development absorbed most of the effort on the project, and it consists of three parts:

Figure 3  
CEDRIC in use on the  
development team's  
concentrator model

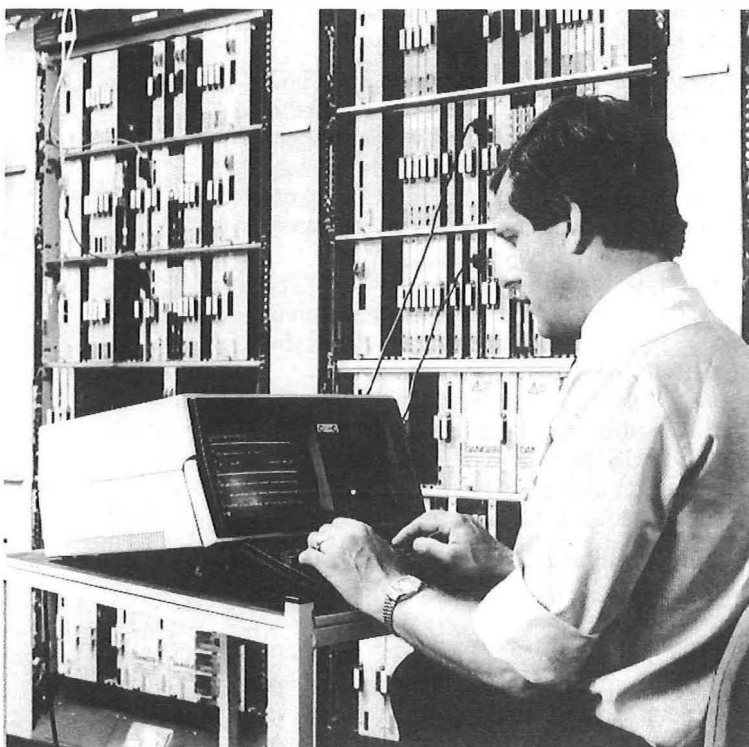

- user interface handler (UIH),
- test files, and
- test file editor (SURE).

The way these parts interrelate with ISIS and with each other is shown in Figure 4.

UIH and SURE are user programs written in a high-level programming language, PLM80. They are both too large to be completely stored in PDS memory at one time. Consequently, each program is divided into a 'root' program (which contains the code required to be permanently stored in memory), and 'overlays' (which contain code to be loaded from disc into the remaining memory space when required). Careful organisation of the overlays has eliminated any appreciable delay in the operation of CEDRIC due to loading time.

A brief description of each part of the applications software follows:

#### User Interface Handler (UIH)

The UIH gives the user interface and I/O utilities that the CEDRIC operator needs. It is a control program that converts commands into messages that can be understood by the module controller. These commands may come from the keyboard, or from the test files as explained later. It also assists the user in downloading exchange configuration data and module controller RAM software. Messages returned from the module controller are interpreted, and appropriate information is sent to the VDU or printer.

#### Test Files

A number of automatic test routines, designed to test individual resources within the concentrator, have been written and stored on disc as test files. They comprise a series of ISIS SUBMIT files, each containing a sequence of ISIS and UIH commands. Test files are invoked using the ISIS SUBMIT routine; they then automatically execute the commands they contain. (The principle is similar to the use of batch files in MS DOS.) Files can be organised into a hierarchy to allow nesting and the building up of complicated test sequences. This is useful because invocation from the keyboard can be restricted to the high-level test files, the number of which can be kept to a minimum.

#### Test File Editor

SURE (Specify User REquirements) is a test file editor that is used to generate test files corresponding to the exchange hardware configuration data build of the particular concentrator in question. Normally, the test engineer has to run SURE just once at the outset of commissioning. The engineer supplies the information required, such as, for example, the number of subscriber private meter auxiliaries, in a straightforward question-and-answer procedure.

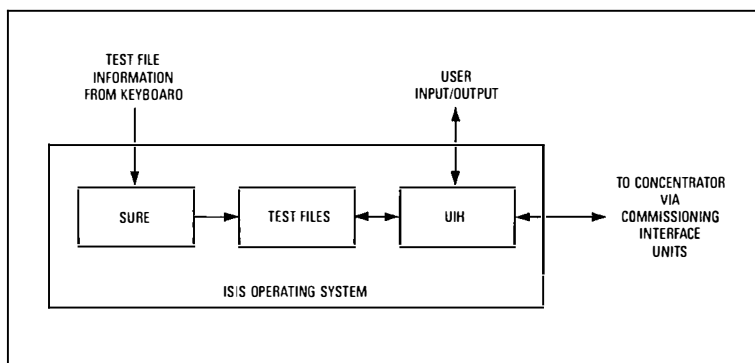

A more detailed description of the CEDRIC applications software is given in later sections.

**Figure 4**  
Interrelation between parts of the CEDRIC software

#### Module Controller Software

As far as CEDRIC operation is concerned, this is simply the data downloaded into module controller RAM at an early stage in the commissioning procedure for SEP2 concentrators. It is not required for SEP1 concentrators.

The software is held on three floppy discs. ISIS is included on all three discs, so that each of them can 'boot up' individually. The first disc holds UIH, SURE and part of the test files. The second disc holds the rest of the test files, and the third the module controller software data. Up to two discs may need to be running simultaneously during commissioning.

#### USER INTERFACE HANDLER (UIH)

The UIH acts as the interface between the user and the concentrator. The program can be invoked directly from the keyboard or from inside a SUBMIT file.

The UIH has three main functions:

- *Command Line Interpreter* The UIH accepts command lines from the keyboard or a SUBMIT file, interprets and validates them, and sends the appropriate data to the relevant module controller via one of the CIU cards. This initiates the desired action or provokes a response.
- *Incoming Message Interpreter* The UIH receives, validates and interprets incoming messages from the concentrator, displaying the data to the user's screen.
- *User I/O Utilities* The UIH provides interfaces to a printer, a results storage file, the MOBIUS automatic call sender, and the disc files that contain exchange configuration data and module controller software.

These functions are described in more detail below:

#### Command Line Interpreter

The command line interpreter expects single letter commands from the inbuilt high-level command language set, followed by a par-

ameter list if appropriate. Commands and parameters are read from the test files or are input manually from the keyboard. Most of the UIH commands result in message transmissions to either module controller of the concentrator via the low-level RS232 controlling software interfaces within UIH. The messages are formed in accordance with the specification of the message transmission subsystem (MTS) and fall into a number of types:

- On-line update messages
- Call processing subsystem (CPS) messages
- Man-machine interface (MMI) messages
- Fault report acknowledge messages
- Routine and diagnostics command messages
- Enter isolation command message
- Mini-test network command messages
- Module controller control messages

A large part of each message, for example, MTS header information, is pre-stored in the UIH code. Any errors in the ordering of parameters are reported to the user.

### Incoming Message Interpreter

This part of the UIH software receives (via RS232 handling procedures), validates, interprets and displays incoming messages from either module controller. Once again, the messages fall into a number of categories:

- On-line update response messages
- Hardware and software fault reports
- CPS messages
- Subscriber parked/cleared reports
- Routining and diagnostics response messages
- Call charging reports
- Mini-test network response messages

If validation is required, the data fields of the MTS format message are compared with the expected message data. Invalid or unexpected message contents are reported. In all cases, the message data is interpreted, and the full received MTS format message is displayed, together with the message type and any specific additional interpreted information; for example, the speech channel associated with a CPS message.

### User I/O Utilities

This part of the UIH is not directly concerned in communication with the concentrator. It provides the ability:

- to vary the amount of information displayed on the VDU depending on the needs specified by the user,
- to copy the VDU information to a line printer for a permanent record of the test results,
- to place results in a file named by the user,
- to read SUBMIT files via the ISIS operating system,

- to read formatted data from a floppy disc to form MTS messages in which both the exchange hardware configuration data and the module controller software can be downloaded,
- to communicate with the automatic call sender MOBIUS,
- to acknowledge specific hardware fault reports automatically if required,
- to transmit periodic handshake messages automatically to the concentrator to prevent it from going into isolation working,
- to display the UIH command help menu,
- to wait for a user to acknowledge a screen prompt via the keyboard (for example, a request to check for dial tone), and
- to give the user warning of CIU-to-UIH link failure.

### TEST FILES

#### File Structure

There are various types of test file, and they are organised into a hierarchy:

- *Top-level test files* These can only be invoked from the keyboard and contain only calls to lower-level SUBMIT files.
- *Intermediate-level test files* These are called from top-level test files, but themselves call only other intermediate or base-level SUBMIT files. Most of these files are edited using SURE before the commissioning begins in earnest.
- *Base-level test files* These are always called from higher-level files and contain no further calls to SUBMIT files.

Each file represents a test or part of a test and comprises a set of console input commands taken from the disc. These are presented to either ISIS or UIH by using the SUBMIT routine. Because the SUBMIT routine allows parameters to be passed, certain files become in effect common 'procedures'. This provides considerable flexibility.

A typical command sent to UIH contains a verb, a resource [5], and the resource number, sometimes followed by supplementary information; for example,

RS DSC 32\*2+7

This command 'returns-to-service' digital speech channel 71.

In certain circumstances, numerical information can be in the form of arithmetic expressions, as above. This feature has been used to make the test files easier to read. For example, in the case above, the 32 reflects the number of channels per digital line termination (DLT), and it becomes clear that the command concerns the third DLT.

### Running Tests

A test is called from the keyboard by typing 'SUBMIT filename', where filename identifies a top-level test file.

All tests begin by stopping both module controllers. Tests will then be performed with one module controller as the worker and the other module controller in stand-by mode. All files are written to give the option of using either module controller as the worker.

A typical test will take a number of paths through the test file hierarchy. Some of the possibilities are shown in Figure 5. Several sorts of file will be involved. Some examples, in the order in which they would be invoked, are given below:

- **Mode file** This base-level file calls UIH. Commands from this file to UIH set the mode (that is, the level of detail displayed on the VDU, and printer on/off) and initiate MTS handshaking (preventing the concentrator from going into isolation).

A mode file also attaches a header to the printout, giving the date and test name.

- **Configuration data files** These intermediate-level files call UIH and present it with data tables for onward transmission to the module controller. The module controller holds information on whether or not various types of resources are in service. The data tables reset this information and then update it.

- **Testing file** Typically, this base-level file calls UIH and sends it commands putting specific resources in service. It then performs the test. Tests fall into one of three types:

(a) Those that invoke the module controller inbuilt routine and diagnostic procedures and report the outcome.

(b) Those that imitate the call processing subsystem, setting up a call and asking for user interruption such as lifting a receiver and dialling digits. The test fails if the correct responses from the concentrator are not obtained.

(c) Those that put the concentrator into isolation and enable the test engineer to check that connections can be made through it. These tests may be done automatically by using the MOBIUS call sender.

- **Exit file** This base-level file calls UIH and commands it to print the name of the current test and the name of the next test to be performed, along with a test outcome message. UIH is then exited and the display modes reset.

All concentrator resources that can be routine and diagnosed are tested with those inbuilt routines; for example, the alarm monitor and the line controllers. Resources such as the per-line auxiliaries are tested by emulating a real call situation and checking for adherence to standard message sequencing. Analogue subscribers' lines are checked using MOBIUS.

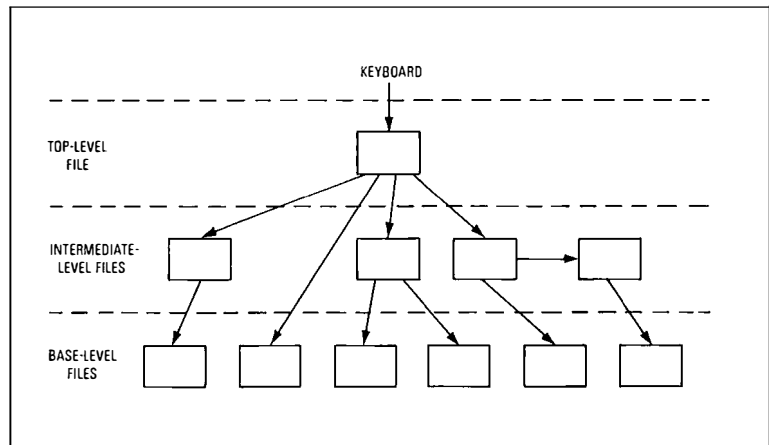

**Figure 5**  
Typical control paths through the test file hierarchy

### TEST FILE EDITOR (SURE)

SURE is a further user program which performs test file editing functions. SURE avoids having to use a general-purpose file editor (such as AEDIT or CREDIT, which are supplied with ISIS) individually on every test file. It can update all the test files automatically, given the exchange hardware configuration. In this way, it saves the commissioning engineer's time and reduces operator errors.

The package is menu-driven and, by following a series of structured prompts, the test engineer provides the exchange hardware configuration data, such as which type of line controllers are in use and their positions. The data is validated as it is entered (for example, checking for out-of-range resource numbers) and invalid entries are highlighted to the user.

The data is stored in a compacted form called a *resource map* and, by further processing of this data, the necessary modifications to the test files can be made. The resource map is saved on disc, so that it can be readily recalled and edited for use as a common source from which to update the test files. This can avoid duplicating a lot of work if it becomes necessary to change information that was supplied earlier in the session. A special routine handles resource map overflows.

Later on in the commissioning, the engineer may have corrected a fault and wish to retest a small part of the hardware associated with a particular resource type. In this case, the engineer would use SURE again, recall the resource map, and make the changes required.

To maintain complete records of the testing process, there is a facility to enter the date, location and test engineer's identity into the header of each test file. An inbuilt software 'lock' ensures that the test engineer enters at least the date before further progress is allowed.

In summary, SURE provides easy entry of complex data and fully automatic processing into test file updates. It also introduces safeguards which help to ensure consistency throughout the commissioning process.

## OBSERVATIONS

Certain features of the CEDRIC project are worth noting:

(a) The project was only feasible because of the collaborative nature of the System X development. BT staff had worked on a concentrator model of their own, and without this experience the opportunity to develop CEDRIC would not have existed.

(b) Because the concentrator was an evolving product, CEDRIC had to evolve too. A virtue was made of necessity, and the development was managed in a number of small steps. It was essential to track any shifts in the concentrator design, and these often translated into revised CEDRIC requirements which had to be implemented quickly. Close contact was maintained with the customer, and comments were taken into consideration at the earliest possible stage.

(c) The evolutionary nature of CEDRIC required a robust system design. For CEDRIC, this crystallised from an early decision to make extensive use of the ISIS SUBMIT routine.

(d) One of the largest overheads was maintaining the target system (that is, the development team's concentrator model) at the current build. Each change in the build-state of the model required at least some degree of regression testing of CEDRIC. This absorbed a lot of effort, but was essential for gaining confidence in the product.

(e) A decision on which computer hardware to use had to be made in late-1984. The PDS was attractive for reasons of its compatibility with software already produced, and at that time its 64 Kbyte of memory was typical of the offerings available at a similar price. Portable machines with more memory were considerably more expensive. By late-1987, this memory space was small by current standards and was definitely beginning to interfere with smooth development. If the project had been going much further, it would have been worth replacing the PDS with more powerful hardware, even though the cost of the change out in the field would have been considerable.

(f) To foster the active involvement of the operational department who were sponsoring the product, they undertook to be responsible for producing the user documentation.

(g) Early in the development, a technician was seconded from the local District to work with the development team. This lasted for over a year and was part of the policy of close attention to user feedback. It worked very well.

## HOW THE USER ENCOUNTERS CEDRIC

The commissioning engineer's first introduction to CEDRIC will probably be at the two-week training course which has been set up

at the British Telecom Training College near Stone, Staffordshire. This has been designed to familiarise students thoroughly with both the procedures for using the CEDRIC equipment and practical experience on a concentrator model which, although limited in quantity of equipment provided, contains all the various types of units found in a 'real' concentrator.

Prior to CEDRIC being used, the concentrator will first have been fully installed. Depending on the organisation within individual Districts, this need not be done by the same team that will carry out the commissioning. However, a certain level of expertise and practice is necessary in order to achieve maximum efficiency, and so minimise the costs of direct labour.

The testing then follows a procedure laid down in a test specification which details all the tests required to be carried out, and the order in which they should be performed. After initial checks to ensure compatibility of the various units have been carried out, and it has been verified that all units have been located as specified in the shelf layout drawings supplied by the manufacturer, preliminary tests are first carried out to ensure correct power up, followed by checks of the outputs from the waveform generators.

CEDRIC is then connected, but, before testing can begin in earnest, it is first necessary to edit the test files to reflect the hardware configuration as installed. This can vary considerably from site to site, and can take some hours to achieve if it has to be done manually, for example, by using a general-purpose text editor, and is prone to error. Such a method was employed on early releases of CEDRIC software, but this function is now performed by SURE, as explained in greater detail earlier in this article. SURE can gather the resource information and update the entire range of test files in just a few minutes.

For SEP2 concentrators, commissioning commences with the module controllers temporarily equipped with ROM boards, instead of the RAM boards supplied with the equipment. An initial test is performed to check that the CEDRIC equipment is communicating successfully with the concentrator, and that the module controllers are functioning.

Assuming that this stage is successful, the 'core' of the concentrator (the control and switching area, ringers and per-line auxiliary controllers) is tested. This is a fully automatic test and takes about three quarters of an hour to run. Tests are then conducted on the line controllers and test access cards, together with a speech test on the digital links which would normally be connected to the parent exchange, but during the commissioning process are looped 'back to back' to provide a continuous path.

All these tests are repeated using the other module controller as the worker, prior to pow-

ering down the concentrator and replacing the temporary ROM boards with the RAM boards. The RAM now has to be downloaded with the software that it would normally contain if it were in service, and this takes nearly half an hour. If it becomes necessary to power down a module controller during later testing, the download is completely lost and the concentrator must be reloaded. By testing the 'core' of the concentrator using ROM boards, the likelihood of this being necessary is minimised.

Testing continues with the 'subscriber' lines, followed by per-line auxiliaries (primarily for subscriber's private meter), mini test network and finally the alarm scheme. Most of these tests require the intervention of the commissioning engineer, for example, to make test calls using telephones specially connected for the purpose, or to confirm that a particular action or event has occurred. The test for 'Mark 3' subscriber line units is, however, worthy of special mention. This is carried out using the MOBIUS universal test call sender and runs automatically, typically testing a 1000-line concentrator overnight.

Before the concentrator is considered to be ready for connection to the parent exchange, an isolation commissioning demonstration is run. This is designed to exercise the concentrator in a similar way to 'live' traffic, by sending a minimum of 1024 calls in a short period of time. It is done under CEDRIC control using the MOBIUS call sender, and uses 16 outgoing and 16 incoming lines.

The concentrator is now ready to be 'integrated' with the parent exchange, after which further call sending demonstration and interworking tests are carried out. However, by this time, CEDRIC has completed its task.

In general, assuming that the quality of the equipment is reasonable, the number of faults is consistent with the specified level of factory testing, and transportation and installation has been carried out with care, then a concentrator can be commissioned by one man in about a week. Certain tests are more efficient if conducted by a two-man team, especially at sites where the main distribution frame is some distance from the concentrator. Equally well, other tests run completely automatically and only require the test engineer to set them running and interpret the results at the end. The staffing arrangement is therefore often a matter of sensible compromise.

## ACKNOWLEDGEMENTS

The authors wish to thank the many people throughout BT who have contributed to all stages of the CEDRIC project. In particular, Mike Foxton laid the foundations, together with John Risbridger and Mike Robards, whose involvement has continued. John Welsh and Nick Webster were mainstays of the development team for much of the project,

and Derek Stock and Geoff Steinberg have given much valuable support.

## References

- 1 OLIVER, G. P. Architecture of System X. Part 3—Local Exchanges. *Post Off. Electr. Eng. J.*, Apr. 1980, 73, p. 31.
- 2 WARD, R. C. System X: Digital Subscriber Switching Subsystem. *Br. Telecommun. Eng.*, Jan. 1985, 3, p. 241.
- 3 RABINDRAKUMAR, K. The Function and Use of Remote Concentrator Units. *ibid.*, Jan. 1985, 3, p. 245.
- 4 STRICKLAND, L. F., and HEWITT, M. A. New Operations and Maintenance Centres for Second Generation System X Exchanges. *ibid.*, Jan. 1985, 3, p. 286.
- 5 BATY, R. M., and SANDUM, K. N. System X: Maintenance Control Subsystem. *ibid.*, Jan. 1985, 3, p. 277.
- 6 PRICHARD, T. W. System X Subsystems. Part 4—Common-Channel Signalling and the Message Transmission Subsystem. *Post Off. Electr. Eng. J.*, Oct. 1980, 73, p. 165.

## Biographies

Joe Startin joined the then Post Office Research Dept. in 1969 after receiving a B.A. in Engineering from Cambridge University. He worked on high-speed logic and gallium arsenide devices, and was awarded a Ph.D. in 1975 after research at University College London. In 1977, he transferred to head a group which worked on various aspects of System X local exchange development. He took responsibility for CEDRIC development at the end of 1984. He is currently working on signalling protocol conformance tester development.

Richard Booth joined the the British Post Office in 1968 as an Assistant Executive Engineer and subsequently obtained a degree in Physics at University College London. Until recently, he has been responsible for System X direct labour installation and commissioning support within the Network Operations Support Division.

Barry Trawford joined the then British Post Office as an apprentice in 1964. After training, he studied at Surrey University where he gained a B.Sc. in Electrical and Electronic Engineering. He then worked in London for 6 years on TXE4 development. In 1978, he moved onto System X analogue local exchange development, becoming a Chartered Engineer in 1980. From 1982, he worked on various aspects of the System X implementation of ISDN until taking over the CEDRIC project management in 1987. He is currently working on signalling protocol conformance tester development.

Colin Denny was awarded an honours degree in Civil Engineering by Portsmouth Polytechnic in 1982. He joined British Telecom in January 1988 as an Assistant Executive Engineer having worked on the CEDRIC project as a contractor. His responsibility has been on CEDRIC test file evolution, particularly for SEP2 concentrators.

Jonathan Barnes graduated from the University of Bath with a B.Sc. in Electrical and Electronic Engineering in June 1987. He subsequently joined British Telecom Research Laboratories as an Assistant Executive Engineer in the Digital Networks Division. He has assisted in the final development of the CEDRIC project, in particular with the UIH and SURE software, and will be responsible for software support for the remainder of the project.

# The Physical Design of Antenna Support Structures—State of the Art

D. G. CLOW, B.A., C.ENG., F.I.MECH.E., M.I.C.E., F.R.MET.S.†

UDC 621.396.67

*This article reviews current knowledge of factors which have to be taken into account to ensure that supporting structures for antennas, whether for terrestrial or satellite microwave communication, meet stringent performance standards in respect of structural strength and antenna deflexion.*

## INTRODUCTION

Microwave radio is an essential element in both national and international telecommunications systems and this makes it imperative that the structures which support the microwave antenna are reliable and of predictable performance yet economic both in initial provision and subsequent maintenance. Antennas and their support structures in most situations experience wind as the major structural load. Coincidental with the growth of microwave radio for public telecommunications from the late-1950s onwards, there was an almost explosive growth in the study of the effect wind has on structures in general. In the 1950s and 1960s, important pioneering work in climatology and aerodynamics was being published. During the same period, engineers were also engaged in extending the bounds of technology in designing long and slender or tall and slender structures which were particularly 'wind-sensitive'. Some notable failures and serious problems with such structures were attributable to the wind. These factors combined to produce an upsurge of interest in what has become known as *wind engineering* (defined as 'engineering related to wind effects'). As a consequence, the designer of antenna support structures has been faced with a plethora of information, not a little of which has been couched in somewhat awesome statistical form. Only recently have codified data utilising the results of the research findings begun to emerge in a form usable in the design office.

## APPROACH TO DESIGN

In the mid-1950s, a steel microwave tower would have been designed on a deterministic basis; that is, by assuming a maximum wind speed with some allowance made for the

increase in wind speed with height, coupled with minimum strengths taken for materials and a 'factor of safety' applied to cover uncertainties. The amount of wind tunnel test data which could be drawn upon was very limited and what was available was difficult to apply with confidence to structures complicated by antennas, waveguides, cables, ladders and platforms.

The present position is that it is possible to take much fuller account of reality in that values attributed to both loading and strength are based on statistical data even if simplifications are made for day-to-day design. However, wind speeds for design purposes are associated with a defined probability of occurrence by the application of the methods of extreme value statistics to wind records. In addition, the use of computers for structural analysis has permitted more efficient utilisation of structural materials. By the late-1970s, the study of the structure of strong winds in time and space had progressed to the point where results could be incorporated in design codes. Wind tunnel methods had been refined in their ability to model the natural wind.

## STRUCTURAL REQUIREMENTS AND TYPES

Table 1 summarises the basic requirements of antenna supports and the influence these requirements place upon the form and detail of the structure. Table 2 classifies the principal forms used for microwave antenna support. Of the types suitable for terrestrial systems, the guyed mast has limited application because of the difficulty of attaining adequate torsional stiffness to restrict antenna deflexion. In the case of towers, the choice between the various options is likely to depend on a number of factors. In an urban area where aesthetic constraints may be severe, then the building-like structures, categories A:(vi), and B:(i) to (iii), will probably be more acceptable than lattice structures. Steel towers will generally be the cheaper option and are particularly suited for construction on remote sites as construction techniques are straightforward and the problems of

† Network Systems Engineering and Technology Department, British Telecom UK Communications  
© 1987: The Institution of Electrical Engineers  
Reproduced by permission, from IEE Conference Publication Number 274, Fifth International Conference on Antennas and Propagation ICAP 87



**TABLE 1**  
**Functional Requirements**

Requirement	Affects
<b>USER</b>	
Support antennas at specified height and pointing direction	Type and form of structure
Serviceability—directional stability	Form and strength of structure
Serviceability—tracking accuracy (SES antennas)	Strength of structure and type of drive system
Reliability—risk of damage	Strength of structure
Capacity for future development	Form and strength of structure
Design life	Design criteria and corrosion protection
Access for staff—permanent/short-term	Structural design
<b>OTHER</b>	
Aviation warning systems	Lighting and paint schemes
Appearance to satisfy environmental control bodies	Structural form

obtaining, transporting and placing large quantities of high-quality concrete are minimised. Alterations to steel structures are simpler to undertake and the towers can be recovered, refurbished and re-used elsewhere if necessary. The maintenance cost for steel structures is likely to be higher than for concrete structures because of the need for regular repainting. Nevertheless, concrete may be subjected to deterioration which, if it does occur, may be difficult to rectify.

**ENVIRONMENTAL INFLUENCES**

Table 3 summarises the assaults from the natural environment which a tall structure may have to withstand. In most situations, wind is the dominant item for structural integrity and will be discussed in greater detail.

**STRUCTURAL CLASSIFICATION**

Structures exposed to the wind can respond in one of three ways, namely:

(a) *Statically*—when the structure is stiff enough for wind effects to be considered by static (or quasi-static) methods of structural analysis. Broadly speaking, this means that the stresses and deflexions follow closely the integrated force of the wind over the structure. Most microwave towers and large reflector antennas will fall into this category. This class is often sub-divided to distinguish between those structures which are small enough to be completely enveloped by a wind gust and those where the full force of a gust affects only part of a large structure.

(b) *Dynamically*—when the structures are not stiff enough to be assessed by static methods as the spectrum of the turbulent wind may contain sufficient energy at a structural resonant frequency to overcome the dissipation of energy by damping with the result that resonant magnification of stress and deflexions occurs.

**TABLE 2**  
**Structural Classification of Microwave Antenna Supports**

<b>A STEEL</b>
(i) eifellised towers
(ii) eifellised towers with antenna galleries
(iii) modular towers
(iv) gantries and other small structures
(v) guyed masts
(vi) cylindrical steel plate towers with antenna galleries
<b>B REINFORCED CONCRETE</b>
(i) tower with antenna galleries above shaft
(ii) tower with antenna galleries around shaft
(iii) combined tower/building
<b>C SATELLITE EARTH STATION ANTENNAS</b>
(i) fully steerable
(ii) limited steerability
(iii) fixed direction
<b>D TROPOSPHERIC SCATTER ANTENNA REFLECTORS</b>

(c) *Aeroelastically*—where structures are so flexible that their motion can interact with their aerodynamics to produce unstable behaviour—this category includes cross-wind vortex excitation or galloping of suspended cables, and flutter. A characteristic of this unstable behaviour is that it often occurs at modest wind speeds.

Vibration of structures can lead to excessive deflexions and the possibility of metal fatigue failure. Aeroelastic-induced oscillation, especially, creates a high risk of premature failure and structures in this category must be modified to eradicate the phenomenon.

Dynamic behaviour depends on the natural modes of oscillation, the stiffness of the structure, its mass, and the amount of damping which can be mobilised. In the case of a

**TABLE 3**  
**Natural Hazards**

1	WIND	—excessive deflexion leading to signal degradation —damage to structure due to wind loads —damage to structure due to dynamic effects	* **** ****
2	ICE/SNOW	—degradation of signal at reflector surface —damage to long thin members and wires —damage to structure due to excess mass —damage to structure due to excess mass and increased windage —hazards from falling ice	* *** **** **** ***
3	HAIL	—damage to radomes —local overloading of horizontal surfaces	*** ***
4	RAIN	—loss of signal due to water on radomes etc.	*
5	HUMIDITY	—accelerated corrosion —delays to structure repainting	** *
6	TEMPERATURE	—distortion of reflector surfaces —difficulty in setting up large reflector profiles during construction —differential expansion effects on cylindrical towers causing deflexions of the structure —low temperature embrittlement of steel	* * * ****
7	LIGHTNING	—damage from direct strokes	***
8	SUNLIGHT	—ultraviolet light degradation of organic materials—paints, plastics	**
9	ATMOSPHERIC POLLUTANTS (natural and man-made)	—corrosion	**
10	DUST FALL	—dust build-up on reflector surfaces and waveguide windows leading to signal degradation —erosion of paintwork by wind-blown dust —ingress into moving parts	* ** **
11	EARTHQUAKES	—excessive deflexions —damage to structure due to dynamic effects	* ****

KEY:  
 \* temporary effects  
 \*\* accelerated deterioration  
 \*\*\* minor structural damage  
 \*\*\*\* major structural damage

cantilever-like structure such as a microwave tower, the first mode of oscillation is normally the most important.

The energy distribution in the wind spectrum exhibits an increase of energy towards the lower end and so towers with a low-frequency first-mode dynamic response are more susceptible to dynamic oscillation. An increase in either mass or length lowers the frequency, but increase in stiffness raises it. In general, however, the stringent microwave antenna deflexion requirements and the strength necessary to resist the wind forces on a number of antennas tend to lead to an inherently stiff structure. Oscillatory energy is dissipated by damping and three sources of damping are important. Hysteresis damping is generated in the stressed material as it is deformed, slip in the structural joints is an important contributor, and aerodynamic damping comes into play when large amplitude vibrations occur.

The dynamic problem for guyed masts is more complex as they are likely to be less stiff than towers and many modes of oscillation will be significant.

### DESIGNING AGAINST WIND

There are several situations to be considered when designing a structure to resist wind action, namely:

- (a) the maximum wind speed at which normal radio performance is still achieved,
- (b) the maximum wind speed for degraded but acceptable radio performance,
- (c) the wind speed at which it would be necessary to stow steerable antennas, and
- (d) the wind speed at which catastrophic failure of the structure is possible.

There is an important difference between a microwave support structure on a terrestrial link and a steerable satellite earth station antenna. It is not normally considered economic to design a large earth station antenna to operate without loss of service due to high winds throughout its life. It is accepted that from time-to-time it will be necessary to stow the antenna in an attitude where the drag forces are at a minimum. In contrast, antennas on terrestrial links are fixed and the supporting structure can gain no relief from wind forces.

The magnitude of extreme winds is generally sensitive to wind direction and the drag, lift and yaw forces on reflector surfaces are very sensitive to the angle of attack of the wind; it may be possible to take advantage of these directional biases into account.

It is convenient to separate the fluctuating wind speed into two parts:

(a) the mean wind speed, which is the product of the large-scale wind climate and is measured over a period sufficiently long to smooth out rapid fluctuations—mean hourly wind records are usually available from meteorological records; and

(b) superimposed upon the mean speed will be gusts which are the product of frictional effects of terrain and topography upon the large-scale air flow. The 3 s duration gust is commonly recorded—the duration stems from the response times of anemometers and gusts of this duration are likely to be of sufficient spatial dimensions to be significant in structural loading.

The sequence in evaluation wind loading is shown in Table 4.

**TABLE 4**  
**Design Sequence for Wind Loads**

REGIONAL	Reference wind speed —anemograms —wind maps
SITE	Terrain —surface 'roughness' —topography  Site reference wind speed  Wind speed variation with height
STRUCTURE	Aerodynamic response —static —dynamic  Mechanical response —stresses —deflexions —foundation loads
USER CRITERIA	Serviceability Failure risk

## WIND EXTREMES

Extreme wind conditions can be generated by one or more storm mechanisms, the most important being listed in Table 5. A given geographical area may experience more than one type of severe storm system, albeit not occurring simultaneously. In many parts of the world, one mechanism will clearly produce the most severe winds, but, in some regions, it will be necessary to examine the wind regime for more than one storm mechanism. In such 'mixed' climates, each weather type has to be considered separately.

The procedures for the statistical analysis of winds associated with the large-scale depression situation (category (i) in Table 5) have been established for many years. The statistical methods were based upon those established by Gumbel refined in recent years by the use of the Lieblein BLUE estimator. The analysis of winds in mixed climates proved to be more difficult but methods of analysis have now been developed notably in the work of Gomes and Vickery [1]. It may be noted that the tornado is not usually considered in structural design for two reasons. Firstly, it is not normally economic to design against the extremely intense and destructive winds which occur in the vortex funnel and secondly, the narrow width of the tornado path is such that the risk of being hit is very low.

## REGIONAL WINDS

Essential to the estimate of extreme winds is a set of wind data which can be relied upon to give information for the specific radio station site. This data can be difficult to obtain especially for sites in areas which do not have long-established sets of meteorological records. Even in those regions where the records are otherwise good, the presence of complex terrain may lead to serious gaps in coverage.

For winds associated with large-scale depressions, the established methods of statistical analysis require 15 years or more of continuous records from which a set of annual

**TABLE 5**  
**Principal Sources of Severe Winds**

Category	Type	Typical Path Width (km)	Principal Regions Affected
(i)	Large-scale depressions	1500	Temperate latitudes
(ii)	Hurricanes/tropical cyclones/typhoons (nomenclature varies according to region)	500	W. North Atlantic, W. and E. North Pacific, W. South Pacific, Indian Ocean, Arabian Sea
(iii)	Thunderstorms	10	
(iv)	Tornadoes	0.1	USA and Australia
(v)	Lee waves, föhn, bora and chinook winds		Near mountain ranges
(vi)	Katabatic winds		Polar regions

maximum wind speeds can be extracted. Recently, however, methods showing considerable promise have been developed which enable shorter lengths of record to be utilised. One approach uses monthly maximum wind speed from a series of independent storm weather systems [2]. Of the some 150 separate depressions which pass over the UK each year, a number will produce high winds which are of interest. The latter method therefore yields a lot of data and periods as short as 7 years are regarded as sufficient to give reliable results.

Whatever method of analysis is used, it is of fundamental importance that the data is of good quality and this may be difficult to establish; it is strongly recommended that the advice of meteorological or other specialist services with appropriate experience in the climatology of wind extremes is sought in the interpretation and use of wind records.

Analysis of wind records provides values of extreme winds with a particular probability of occurrence. The most common basis used for design in many countries is the 'once-in-50 years' return wind—this wind has a probability of exceedance of 0.02 in any one year. A longer return period wind will need to be adopted for major city centre structures (this is equivalent to using a lower annual probability wind speed), and shorter return winds of, say, 20 years may be more appropriate for satellite earth station antennas.

It is normal practice for the result of the analyses of the wind records of a region to be presented in the form of an 'isopleth' map which shows, superimposed on a geographical map, 'contours' of wind speeds of equal magnitude at a standard height of 10 m above ground in open flat country. These winds are referred to as the 'reference wind speeds' and are associated with the generalised regional wind climate.

### SITE WINDS

To determine the wind speed environment at a given location, the regional reference wind speed must be adjusted to account for local conditions, namely:

(a) *Ground 'roughness' in the vicinity of the site* The rougher the surface, the more the air flow will be retarded but it becomes more turbulent. The 'gust factor', that is, the ratio between the mean wind and the peak gust speeds, will be larger as roughness increases—typically, ranging from 1.2 for open level sites to 1.8 for city locations.

(b) *Variation of wind speed with height* Again the variation will depend on ground roughness. The less the flow is disturbed by obstructions, the more rapid will speed increase with height.

(c) *Size of the structure* A large structure is not likely to be enveloped by the

strongest gusts and some relief of loading can be allowed to account for this.

(d) *Design life* The longer the structure is intended to remain in position, the higher the wind speed it will experience for a given level of probability of occurrence.

(e) *Special topographical effects* Structures located on hill tops, on escarpments or cliff edges or in sheltered valleys are likely to experience a markedly different wind-speed environment compared to level sites. The calculation procedures to account for such effects can be fairly cumbersome especially as winds blowing from different directions are likely to pass over different types of terrain.

### AERODYNAMICS

Having evaluated the wind speeds to be allowed for in design, the next stage is to determine the pressures and forces which are exerted by wind upon the structure. Until the 1960s, the data available for the design of lattice structures was based on wind tunnel tests carried out in the 1930s. The use of these data for evaluating the forces in a complex structure like a microwave tower with many ancillaries such as ladders, waveguides and antennas was problematic. Another shortcoming of early wind tunnel tests was that they were undertaken in aeronautical wind tunnels in smooth-flow air conditions. Smooth-flow testing is valid for testing small sections of structures and the results can be utilised for evaluating the loads on lattice structures. This test method is not valid for determining pressures on large dish antennas or building structures which present a large bluff face to the wind. To gain data for such structures, it is necessary to model the natural wind both in terms of turbulence and increase of velocity with height, otherwise misleading results will be obtained.

Wind tunnel testing is a time-consuming and expensive operation for deriving wind loading. Testing of specific structures is reserved for special cases but, for the majority, designers need codified parametric data. The new British Standard BS8100 [3] gives detailed information based upon parametric studies of wind forces on lattice tower models and, unlike earlier codes, it has been found to be effective in facilitating the calculation of wind forces on complex towers.

### SOME OTHER ENVIRONMENTAL HAZARDS

#### Temperature

Antenna support structures will be subjected to a very wide range of temperatures. Exposed members of structures will attain temperatures as low as the lowest ambient air temperature. The most important matter related to very low values is to ensure that steel com-

ponents in tension, especially when welded and of thick material, are fabricated from steel with a low ductile/brittle transition temperature otherwise brittle failure may occur. At the other extreme of the temperature range, the surface temperature of metalwork exposed to the sun may be assumed to attain a temperature 20°C above the shade temperature. Even in a temperate climate like that of the UK, exposed surfaces may experience a range of from -20 to +50°C. The choice of finishes, sealants etc. will need to take account of such conditions. Differential expansion and contraction need consideration where, for example, aluminium reflector panels are fitted to steel backing structures if undesirable temporary or permanent distortion is to be avoided. Whole structures are not likely to be deflected significantly by differential heating; lattice structures will not develop significant temperature differentials between faces and, even in the case of towers with concrete shafts, the bending resulting from the differential expansion of the sunny and shaded sides of the shaft is not likely to lead to troublesome radio beam deflexion.

### **Snow and Ice Loading**

The accretion of snow and ice on a structure can affect it in several ways. Heavy accumulations may add significant mass; this can be a serious hazard to guyed masts if ice on the guys is not evenly distributed around the mast. Ice and snow also adds to the area exposed to the wind. Although the wind speeds expected where such conditions exist are likely to be lower than those under extreme wind without accretion, it is necessary to check safety margins with reduced wind speed on an iced structure. The accretion of ice on slender structural components can form an aerodynamically-sensitive cross-section which in the presence of wind may set up aeroelastic vibration of the members; again, the mast is the type most at risk as guy ropes are especially prone to this form of vibration which could lead to fatigue failure of guys or attachments. Finally, ice breaking off the structure poses a danger to antennas, waveguides, buildings and personnel, and protection will be needed at sites where icing occurs.

Ice can form on structures in several ways:

(a) Freezing rain may turn to ice on striking a cold surface. This form of ice has little entrained air and is the densest form. It tends to adhere strongly to surfaces and is called *glazed frost*, *glaze ice* or *clear ice*.

(b) The least dense form and fragile is rime ice which is formed when fog or cloud blows on to a cold surface and droplets freeze on the surface and entrap air.

(c) Intermediate in density is ice formed by the freezing of wet snow on a surface or by the successive partial melting and freezing of deposited snow.

Data on icing are generally less secure than that for wind and tend to rely on a few visual observations. Most design codes provide simple recommendations for design but recent British Standards have moved towards a probabilistic approach as more data becomes available.

## **STRUCTURAL DESIGN**

### **Superstructure**

Design in steel or concrete is perhaps the best understood and codified element in the whole design process because it has close affinities with methods used in other major areas of civil engineering construction—buildings, cranes, offshore structures etc.

Many nations have their own design standards for structural design in steel or concrete. Further consideration is not appropriate here except to state that generally such standards are likely to be biased towards conventional buildings where wind loading is only a small proportion of the total structural load. Care will be needed in applying the requirements to antenna structures where wind loading predominates.

### **Foundations**

The foundation tends to be a neglected facet of structural design yet it is critical for the reliability of the superstructure. Design and construction of foundations follow general civil engineering practice with perhaps two exceptions. Firstly, in overturning, moments generated by wind forces may give rise, in the case of steel tower footings and guy anchor blocks of masts, to considerable uplift forces which must be resisted by the foundation. Secondly, in the case of satellite earth station antenna foundations, care will be necessary to limit the amount of differential and absolute settlement which can take place. Allowable settlements in this application are generally less than those accepted for conventional buildings.

An essential precursor to foundation design is a knowledge of the soil conditions at the site. Little information is likely to be available for most radio station sites which are generally located in remote positions. A geotechnical investigation at an early stage of the site selection process is important so that the sub-soil conditions can be determined. Although such an investigation is of prime importance for structural safety, a foreknowledge of the soils will minimise the risk of cost escalation where unanticipated conditions are only discovered when construction is underway. If poor conditions are found at an early stage, it may prove to be possible to resite the structure and so avoid excessive foundation expenditure; often soil conditions can vary quite considerably within a short distance.

It should be stressed that the site survey is not primarily a geological survey for the main objective is to determine the physical properties of the soil or rock for supporting imposed loads; the identification of the soil or rock is of secondary importance.

### Safety Margins

In the process of designing the structure or the foundation, an extra margin of strength above that theoretically needed to resist the applied loading is provided. This may be provided by factoring either loading or strength, the most common method being to use a 'load factor'. Load factors cover many aspects other than uncertainty in loading as shown in Table 6. In the case of steel structures, the compression members are critical and load factors are applied, typically in the range 1.5-1.7. If the data relating to all aspects of the structure and its loading are especially well understood, then lower values have been used. A desire to erode safety margins should

**TABLE 6**  
**Need for Safety Margins**

Stage	Source of Weakness
Specification and design	Inadequate data. Wrong assumptions. Misapplied theory. Calculation error. Incorrect drawings.
Material properties	Undetected substandard material. Unanticipated changes with time, temperature etc.
Manufacture	Inappropriate techniques leading to degradation of material properties.
Assembly and installation	Misassembly. Parts overstressed by forced fitting. Incorrect procedures used.
Operation	Inadvertent overloading. Misuse. Corrosion and decay. Wear. Fatigue. Ill-considered modifications.

be resisted especially as the cost does not increase proportionately to the increase in reliability.

The greater precision of design means that the hidden margins of strength are eroded and reserves against ill-considered overloading of structure are much reduced.

### CONCLUSION

This paper has outlined the major elements requiring consideration in designing antenna support structures. A wide range of disparate disciplines require to be drawn upon to produce a safe economic structure. In some areas of knowledge, data may be fragmentary but experienced professional resources will need to be called upon in the production of a successful design.

### References

- 1 GOMES, L., and VICKERY, B. J. Extreme wind speed in mixed climates. *J. Indust. Aerodyn*, 1978, 2, 331-344.
- 2 COOK, N. J. The designer's guide to wind loading of building structures, Part 1. Building Research Establishment, Garston, England and Butterworths, London, England, 1985.
- 3 British Standards Institute BS8100: 1986. Lattice towers and masts. Part 1, Code of Practice for loading.

### Biography

Don Clow joined the Engineer-in-Chief's Office of the Post Office in 1948 and in due course became an Assistant Engineer and then Executive Engineer in Radio Branch on the design and construction of HF antenna systems. In 1969, he transferred to the External Plant Division to head the group responsible for design and consultancy work associated with masts, towers and satellite earth station antennas. He is currently Head of the Civil and Mechanical Engineering Section. His section designs and evaluates equipment and working practices for underground duct and tunnel systems, cabling equipment and cabling vehicles and pressurisation, tools and general mechanical aids. He has also worked for the ITU in Nigeria and India. He chairs the Executive Committee of the National Joint Utilities Group (NJUG) and is Co-Chairman of the Highways and Utilities Committee (HAUC). In a personal capacity, he serves on the Government's Street Works Advisory Committee.

# Towards a European Telecommunity

A. BOESVELD†

UDC 658.3.04

*European co-operation in the field of telecommunication services started in Europe nearly 140 years ago. The modern technology makes it nowadays essential to intensify this co-operation between researchers, developers, manufacturers, network operators and service providers. Standardisation is becoming the keyword for telecommunication and all telecommunication-related activities.*

*Examples demonstrate the essential role of the telecommunication administrations and the stimulating effect of the European Commission in this field.*

*The variety in culture and history is at the same time the power and the weakness of Europe. Co-operation in precompetitive research programmes like ESPRIT and RACE leads to results above expectation. Telecommunication engineers can realise a basis for future prosperity in Europe, where politicians still are struggling about old borders.*

*More effective organisation structures for the study and standardisation activities are needed, and partly already realised. It is essential that European telecommunication engineers know their responsibility and play their role in the development of the future community, the telecommunity.*

*This article is based on a paper\* given at the 26th European Telecommunications Congress that was held in Athens from 31 August–5 September 1987, and is reproduced by permission of the Federation of Telecommunications Engineers of the European Community (FITCE).*

## INTRODUCTION

Europe was the birthplace of international co-operation in the field of telecommunication. The first bilateral treaty between states was signed by Prussia and Austria on 3 October 1849, in respect of a telegraph line between Berlin and Vienna. This led to the establishment a year later of the Austro-German Telegraph Union.

These early steps paved the way for the foundation of the International Telegraph Union in Paris on 17 May 1865, which, at least as regards telegraphy, served to unite a much-divided Europe.

Following the invention of the telephone, the Union also co-ordinated, from 1885 onwards, the establishment of international agreements for telephony. But it was not until the Madrid conference of 1932 that separate telephone regulations were laid down.

In the meantime, the world had seen the advent, around the turn of the century, of radio communication with ships. This prompted the seafaring nations of the world to set up the International Radiotelegraph Union at a meeting in Berlin in 1906.

In 1932, the International Telegraph Union and the International Radiotelegraph Union merged to form a single body called the *International Telecommunication Union* (ITU). This history makes the ITU the oldest co-operative bond between different member states. The ITU survived two World Wars and since 1949 has been a specialised agency of the United Nations. European telecom-

munications engineers should be proud of this inheritance and should do their utmost to preserve it. It is thanks to the specialised committees working within the ITU, that is, the CCITT and CCIR, which issue recommendations in respect of technical and operational matters, that we today have a worldwide telecommunications network.

After World War II a need emerged for closer co-operation between the PTT organisations in Europe. It resulted in the foundation, on 26 June 1959, of the CEPT, the European Conference of Postal and Telecommunications Administrations.

The CEPT has no ties whatsoever to any political or economic organisation and it works according to the spirit of the recommendations of the ITU and its counterpart postal body, the UPU. The CEPT now has 27 members.

Shortly after the CEPT came into being, FITCE, the Federation of Telecommunications Engineers in the European Community, was founded in October 1961. As can be seen from the programmes of the many annual conferences already held, FITCE examines in depth the wide variety of problems confronting telecommunication engineers.

In the meantime, progress was also being made towards the political and economic unification of Europe. As early as 1947, Belgium, Luxemburg and the Netherlands together set up the Benelux customs union. On the initiative of the Frenchman Robert Schuman, the European Coal and Steel Community was established in 1951. Six years later, in 1957, a number of western European countries decided to establish, by the Treaties of Rome, the European Economic Community (EEC) and the European Atomic Energy Community (EURATOM).

† Netherlands PTT

\* BOESVELD, A. Towards a European Telecommunity. *FITCE Review*, Jan./Feb./Mar. 1988, 5(1), p. 48.



Today, the EEC has twelve member states. Within the Community, there was a feeling that the advisory powers of the ITU and CEPT were inadequate. In order to achieve a European regulatory regime in the telecommunication field, the European Commission (EC) has, since 1983, been directing all kinds of specialised activities. A separate body was set up to oversee these activities; it is called the *Senior Officers Group for Telecommunication (SOGT)*.

The objective is to have, in 1992, an open European market for telecommunications services and equipment, and to stimulate joint European projects such as realisation of an integrated broadband digital communications network. With this approach the EEC hopes to put European telecommunication equipment manufacturers, service-providers and network operators in a stronger position in relation to competitors in the United States and Japan.

Throughout history an ever-divided Europe has played an important role in the establishment of international organisations. But these organisations did not always function with sufficient efficiency to keep pace with modern international developments. The time has come to create new structures which can meet the requirements of a changing world. The nations of Europe have always been acutely aware of the need to establish international agreements. With a stronger structure, the European organisations would in any event be able to achieve faster results. However, cultural differences from country to country cannot simply be rubbed out by means of international organisations. And neither should they be!

## STANDARDISATION

International technical co-operation results in standardisation, or, in other words, the formulation and application, with the involvement of all parties concerned, of rules and standards aimed at creating order and unity in fields where variety is either superfluous or undesirable. Standardisation is not a goal in itself, but rather a means to achieve a general improvement in efficiency, to limit the variety of different apparatus and systems, and to enable interchangeability.

There are specialised international organisations which deal with standardisation. The oldest is the International Electrotechnical Committee (IEC), which was founded in 1906. For other fields, there is the International Standards Organization (ISO). By a lucky coincidence, the headquarters of the IEC and ISO are located opposite the offices of the ITU in the Rue de Varembe in Geneva. I feel obliged to note, however, that the officials of the three organisations do not seem to cross the street often enough.

On a European level, we have the CEN (the European Committee for Standardiza-

tion) and the CENELEC (the European Electrotechnical Standards Coordinating Committee).

In 1984, the CEN, CENELEC and CEPT together decided to establish the Information Technology Standards Steering Committee (ITSTC), whose task is to co-ordinate standardisation in the overlapping field.

Standardisation is a vital precondition for an open market. In order to achieve a harmonised and liberalised market for information technology and telecommunication, the European Commission called upon European manufacturers in 1983 to agree on better co-operation as regards standardisation. This call led to the establishment, in March 1983, of the Standards Promotion and Application Group (SPAG), a co-operative body comprising Europe's 12 largest manufacturers in the field of information technology. SPAG quickly put forward a recommendation to the European Commission regarding the further harmonisation of existing basic standards. The concept of 'functional standards' was defined more precisely; that is:

“functional standard” means a standard that has been drawn up for the purpose of fulfilling a more complex function such as is required in order to ensure system interoperability, that is generally obtained by linking more reference standards which have already been adopted, and that has been approved pursuant to the statutes of the standards bodies (CEN/CENELEC and CEPT).

SPAG also indicated how very specific telecommunications functions needed to be realised in Europe in the future.

In doing so, SPAG gave the European Commission a basis for a European supra-national telecommunications policy.

One of SPAG's tasks is publication of the Guide for the Use of Standards (known simply as *GUS*), which serves as a kind of technical foundation for the standardisation work performed by ITSTC.

Actual agreement on standardisation takes place within CEN/CENELEC and the CEPT according to their own procedures; national standards bodies also play a role in these procedures. Within CEN/CENELEC, the aim is to agree on what is known as an *ENV*, a European Experimental Standard. This is a 'pre-standard' which is used for two to three years on a trial basis, after which can be agreed the definitive text of the standard.

At the present time, there are ENVs for local area networks (LANs) and message-handling services (MHS).

The CEPT follows a somewhat different procedure. A special body called the *Technical Recommendations Advisory Committee (TRAC)* examines the existing recommendations and selects those which can be converted into a NET, which is a European Telecommunications Standard.

Before a decision is taken as to whether or not to introduce a NET, the text of the proposed standard is published and all interested organisations are given an opportunity to submit their comments within a specified time. A similar procedure is followed with ENVs.

NETs and ENVs are of equal force in the sense that both are used by the EEC as a basis for European regulations.

Besides the organisations of manufacturers and network operators, more and more multinational groups of users are being set up. At an international level, there is INTUG (the International Telecommunications Users' Group), while in Europe we have EMUG (the European MAP-User Group) and OSITOP (the European Organization of Users of Technical and Office Protocols). So far, little has been heard from the grass-roots consumer, that is to say individual users and small businesses. For the time being, it is therefore up to the PTTs to protect their interests. The overall picture of standardisation in telecommunications and information technology is that the initiatives undertaken by the EEC have accelerated the process, but that the organisational structure has now become unclear. To put it another way: we now have more players on stage, but finding the right cast may well prove to be difficult.

The latest news from the standardisation front is that the CEPT is now setting up an Institute for Telecommunications Standards, in which the CEPT will attempt, together with manufacturers and users' organisations to produce standards more quickly.

## THE ROLE OF THE EUROPEAN COMMISSION

On the stage of international standardisation, the European Commission has the task of stage manager, although not everyone recognises it as such. The EC stimulates various developments, known as *action lines*, by on the one hand providing financial support and on the other by exercising legal powers (and generally with widespread publicity). Without exception, these action lines are aimed at bringing about greater co-operation and an improvement of Europe's economic position.

Since telecommunications will be one of the key factors in Europe's development in the years ahead, it is not surprising that political interest is increasingly being focused on this important field.

In 1983, the EC published six major action lines:

1. Setting objectives for telecommunication policy within the Community.
2. Joint research and development activities.
3. Development of interface standards for terminals so as to create an open intra-European market and to portray unity to the rest of the world.
4. Joint development of the transnational part

of the future telecommunication infrastructure.

5. Optimum use of telecommunications to assist the less-favoured regions of Europe.

6. The opening of the telecommunication market for governmental procurement of telecommunication equipment.

Over the past few years, the following decisions have been taken with regard to these action lines:

### Recommendations (not binding)

- implementation of a common approach in the field of telecommunications;
- first phase of opening up access to public telecommunication contracts;
- co-ordinated introduction of ISDN;
- pan-European digital mobile communications system.

### Directives (with legal force):

- initial stage of the mutual recognition of type approvals for telecommunication terminals;
- MAC package of television standards;
- standardisation in the fields of information technology and telecommunication;
- the making available of frequency bands for the pan-European digital mobile communication system.

### Regulations (with budget):

- STAR programme for the development of less-favoured regions;
- RACE programme for research on and development of advanced (broadband) communication;
- TEDIS programme for the electronic exchange of trade data (Trade Electronic Data Interchange Systems).

### Resolutions:

- use of videoconference and videophone techniques for intergovernmental applications.

On 30 June of this year [1987], the European Commission published a green paper dealing with the development of a common market for telecommunication services and equipment. In this 192-page document, the EC sets out its objectives, which are summarised in six new action lines:

1. Creation of a European Telecommunications Standards Institute.
2. Common conditions for Open Network Provision (ONP).
3. Common development of Europe-wide services.
4. Coherent European position regarding future satellite communication in the Community.
5. Coherent concept of telecommunication services and equipment with regard to the Community's relations with third countries.

6. Common analysis of the social impact of new services and the conditions for their smooth introduction.

The SOGT must hold detailed discussions on the green paper before the text, with any amendments, can be placed before the European Council of Ministers for ratification. Nevertheless, some initial comments can be made on these action lines.

As regards action line 1 (creation of a European Telecommunications Standards Institute), the Directors-General of the CEPT member states will meet on 7 September [1987] with the aim of reaching firm decisions regarding the proposal to set up such an institute. [*Editor's Note:* The European Telecommunications Standards Institute has now been established.]

Action lines 2 and 3 (common conditions for ONP and the common development of Europe-wide services) will certainly require detailed discussion. Common conditions for ONP may necessitate a legal measure in the form of an EC Directive of Recommendation, while the common development of Europe-wide services could encroach upon the operational responsibilities of individual PTTs.

Action lines 4 and 5 (coherent European position on future satellite communications and a coherent concept of services and equipment in relation to third countries) are closely related to the economic policies pursued by individual member states.

I believe action line 6 (common analysis of the social impact of new services and the conditions for their smooth introduction) is part and parcel of the responsibility of the PTTs to operate in a way which is in the best interests of society as a whole.

Over the coming years, we can expect these action lines to produce the following results:

1. A greater interest in telecommunications matters, particularly in political circles.
2. A stronger drive by manufacturers, network operators and users to combine efforts.
3. A more perceptible open market in Europe.

Together, these developments will greatly influence the work of telecommunications engineers. I would therefore now like to look at this aspect in more detail.

### **SOME FEATURES OF MODERN TECHNOLOGY**

Modern digital technology—as regards both hardware and software—is far different from the earlier electromechanical and electronic techniques. This is reflected by the relatively expensive research and development programmes which form the basis of new telecommunications systems.

The expenditure on R & D has to be earned back through sales by manufacturers. Very roughly speaking, we can base our thinking on the following figures:

- 6% of the revenue from sales in the telecommunication industry can be spent on research and development;
- the cost of developing a new switching system is  $10^9$  ECUs; and
- for each line the manufacturer receives 500 ECUs.

From these figures, we can conclude that, in order to recover R & D expenses, a manufacturer must sell  $3 \times 10^7$  lines. With roughly  $10^8$  European Community and a maximum growth of 10%, the scope for independently-operating manufacturers on the European market is clearly limited. According to current forecasts, not more than three independent manufacturers will ultimately survive. Another salient feature of modern technology is that fewer and fewer workers are needed for the actual production process, which means that production costs per item are dropping considerably. On the one hand, this is resulting in redundancy among workers, while on the other it means that, in order to make a profit, a manufacturer needs to secure a large share of the market.

So, after developing a new system, a manufacturer will obviously try to make as many sales as possible within a short space of time. A similar situation exists in the computer industry, where there is enormous pressure to get new system after new system on to the world market. In the telecommunications industry, we are now seeing, as a consequence of this situation, a relative increase in the number of R & D personnel against a stronger decrease in the number of production personnel.

Telecommunications is increasingly becoming a knowledge-based industry. Software costs are now far higher than equipment costs.

The presence of a large R & D staff is resulting in a greater number of follow-up developments and an earlier start on new generations of systems. This is confronting network operators with the faster economic obsolescence of the systems they have in place.

While new technology enables cheaper production, the annual costs incurred by the PTTs are not decreasing to any appreciable extent, because of the short write-off periods. On the other hand, a certain decrease can be expected in the number of maintenance and operating personnel required by the PTTs. Nevertheless, users should not expect any major changes in tariffs.

A major advantage of new technology is the possibility to provide a far wider range of services. This opens up a potential source of profits for the PTT administrations, who can provide custom-made services to various segments of the market by means of advanced telecommunication networks. When procuring new systems, it is therefore essential for the PTTs to ensure that those systems

are future-proof, so that new services can be realised easily as and when they become available.

The essence of my message is that, in the years ahead, the PTTs must be more conscious of market requirements and act accordingly. To make this possible, the PTT organisations in various European countries are to a lesser or greater extent being uncoupled from government control.

Increasingly, PTTs are finding themselves in competition with other parties who use telecommunications for their business activities so as to provide their customers with value-added services. While on the one hand the PTTs will continue to provide basic services like telephony, Telex and data transmission on a concessionary basis, they will on the other hand have to contend with competitors in the market for new services and advanced terminal equipment.

Strategically, it is of the utmost importance that the PTTs should remain among the suppliers operating in this competitive market. After all, that is the only way to keep in touch with end-users and, consequently, to keep abreast of market and user requirements. If the PTTs were to allow themselves to be squeezed out of this market for advanced telecommunication facilities, there would be a very real danger that other suppliers would provide all the lucrative services. This would relegate PTTs to the position of simple line-suppliers who would have to be satisfied with marginal earning-capacity. At the present time, I do not think that is a very attractive prospect for most administrations.

## EUROPEAN CO-OPERATION IN RESEARCH AND DEVELOPMENT

Looking back over the years, one has to conclude that it has often proven difficult to arrive at single European or worldwide standards in telecommunications and information technology.

Basically, the root of the problem was that equipment and services were developed by individual countries and sometimes even by individual companies. So each country implemented its own particular solution. Since vast amounts of money had generally already been pumped into these national developments, the various manufacturers and/or PTTs were unwilling to reverse their policy, and thus an obstacle was thrown across the path of standardisation.

If we are to avoid this situation in the future, at least in Europe, it is vital that those who initiate the development of new equipment and services, the R & D experts, should get together at an early stage.

They will then be able to influence each other's thinking and there is every chance that they will arrive at a common stance; in other

words, the beginning of the standardisation process.

Co-operation between R & D experts in international projects is the next step. The EC has already launched various activities in this direction, such as:

- *COST (Cooperation Européenne dans le domaine de la Recherche Scientifique et Technique)*. This is a combined effort by all European OECD countries which got underway in 1970 on the initiative of the EC. The project involves co-operation in joint research projects, whereby each partner bears his own costs and has access to the results of all the other partners. The COST programme embraces a very wide field of research. In telecommunications alone, some 14 projects are already in progress.

- *ESPRIT (European Strategic Programme for Research and Development in Information Technologies)*. This is a Community programme comprising a large number of projects which receive a subsidy of up to 50% from the EC. The programme was launched on 25 May 1983, and has now entered its second phase.

- *RACE (Research on Advanced Communication for Europe)*. In this project, PTTs, telecommunications manufacturers and scientific institutions are working together. Some of the activities, notably technology development, are being subsidised for up to 50% by the EC. RACE is a concerted programme aimed at the introduction of integrated broadband communication (IBC) in 1995. The first stage, the RACE definition phase, started in 1985 and was concluded towards the end of 1986. The main phase of RACE will probably get underway early in 1988 and is expected to continue up to 1992.

In a number of cases, European co-operation in the field of R & D has been very successful indeed. There is great enthusiasm among those involved and the contact with colleagues from other countries has proved to be a source of inspiration.

Major progress is being made, both in the development of the necessary basic technologies (for example in the field of optical switching) and in application preparation (that is, the pre-commercial phase).

Here we see an aspect of the European situation which can give Europe an advantage over Japan and North America, where big laboratories work on very large-scale developments.

The danger inherent in the situation in Japan and North America is that a decision will be taken at a very early stage to pursue one particular line of development, which, because of the substantial investments involved, has to be continued despite better ideas which may emerge in the meantime. There is then every likelihood that a wrong

course of action will be pursued for too long, as we have seen in the past with the development of electronic switching systems. (For example, the Bell labs in the United States clung for too long to use of the Ferrite sheet and twistor memories before being forced to adopt the magnetic core memory some years later. In Japan, they tried for many years to stick to the tunnel diode invented by Nobel prize winner Esaki.)

In Europe, on the other hand, where we have numerous smaller laboratories, it is easier to try out ideas locally and then to compare the results with those achieved elsewhere. This greatly reduces the risk of failing to recognise the most promising development in time. It presents Europe with an excellent opportunity to opt for original developments at the right time. It goes without saying that we must make sure that the various lines of development do not proceed beyond the point of no return. For we would then be confronted with the 'not invented here' effect which would once again result in a lack of European standardisation.

The significance of international co-operation in the field of R & D cannot be overestimated. It is far cheaper for European manufacturers and PTTs to let their R & D experts travel a little more than to push on with their own ideas until ultimately a no-chance product comes out of the pipeline.

The stimulating and co-ordinating role played by the EC is extremely important in this regard.

### **AN ATTEMPT AT EVALUATION**

What is the value to EEC countries of European co-operation in the telecommunications field?

Firstly, it has advantages for suppliers, because enlargement of their markets can provide them with a sufficiently broad basis to undertake new developments.

Similarly, an open market for purchases is very much in the best interests of the PTTs, because competition in the industry means good and inexpensive systems and equipment will be available.

Faster European standardisation will also benefit service-providers and users, while European co-operation in research and development provides laboratory staff with extra incentive and yields valuable results.

But is the situation as perfect as it seems? Unfortunately it is not, for there are some very real dangers on the horizon. The increasingly far-reaching regulations being issued by the European Commission, for example, are threatening to mushroom into a European bureaucracy, at the very time when most countries are trying to achieve deregulation. Similarly, the excessive pressure to speed up standardisation and to get quick results from research projects means there is a danger of products being born prematurely.

And a well-regulated European telecommunications market may open the door to suppliers from third countries. We might then see an American service-provider using Japanese equipment to serve European customers. All that would be left for the PTT and the present European manufacturers would be an uninteresting share of the market.

By placing the emphasis squarely on its own developments, Europe might fail completely to link up with international standardisation. This would saddle the world with at least two different families of standards. With its means to encourage developments and to impose legal measures if necessary, the European Commission can do much to cultivate the positive effects of European co-operation, while at the same time preventing any negative effects.

The commission should therefore conduct a policy aimed at stimulating the healthy evolution of telecommunications in Europe and it should impose regulations only when strictly necessary. But the Commission should not endeavour to take over tasks in standards organisations and consultative bodies which are already being performed satisfactorily by the PTTs and the industry.

### **THE FUTURE**

There is no way back. It is only by increasing the co-operation between member countries that we can avoid a situation whereby Europe is relegated to a third-rate position in the world economy. There is no doubt that telecommunications will be a mainstay of Europe's economic development in the years ahead. Telecommunications engineers will therefore be called upon to make key contributions to the achievement of our common goal:

**'The European Telecommunity'**

# Common European Objectives

P. C. JONES, B.A., A.M.I.E.E†

UDC 654.07

*This article explores the broad objectives of British Telecom, which are contrasted and compared with those of other European public telecommunications operators (PTOs), in order to investigate the scope for common Europe telecommunications policies. These policies are often a function of the relative state of liberalisation, which in turn is governed by regulatory legislation. BT's progress in achieving its objectives is discussed with particular regard to providing a high-quality low-cost network. There is also mention of the progress that Europe has made in harmonising its telecommunication systems. The advantages of co-operation between European PTOs and manufacturers are emphasised.*

*The article is the author's presentation in September 1987 at the 26th FITCE\* Congress in Athens‡, for which he was awarded a prize, and is published with the permission of FITCE. Some of the details have now changed, but this merely reflects how rapidly the telecommunications scene in Europe is changing. The principles, however, have not changed—1992 presents both PTOs and telecommunication equipment suppliers with an opportunity that must not be missed.*

## INTRODUCTION

I am delighted to be able to speak to you today about common European objectives. My view of those objectives is heavily influenced by the changes that have taken place both inside and outside British Telecom. The major changes being privatisation and, perhaps more importantly, deregulation and the breaking of the monopoly on the supply of the basic services. It must be a fundamental objective of almost all public telecommunications operators to provide a good-quality service at low cost. Differences of opinion arise when considering how and to what extent the fundamental objective is to be achieved. For most public telecommunications operators (PTOs), certainly for BT, a good-quality service must involve the notion of customer choice, although most PTOs do give some choice in products, services and to some extent price. I believe customer service, particularly with regard to price, can best be achieved when there is competition. Our customers' perceptions of choice and how that translates into needs are therefore a function of the amount of competition, or if you like, the degree of liberalisation.

I shall discuss the objectives of BT in the context of liberalisation and the implications for the network strategy in both the medium and the long term. I will then show the objectives as found in the European Commission's Green Paper and contrast them with the latest information I have about the existing state of liberalisation throughout Europe. I shall then discuss the progress towards the creation of a large European market necessary for Euro-

pean manufacturers to compete effectively with America and Japan in international markets.

## OBJECTIVES OF BT

The prime objective of BT is to become one of the top telecommunications companies in the world—we call it *Top Telco*—by the end of the decade. To achieve this, we need to consider four key elements of the Business.

● *Quality* Customers should choose BT because they want to and not because they have to. Of course, that is where customers do have a choice. At the moment, there is little competition in basic services for our residential customers. However, we have a potentially strong competitor in Mercury Communications Ltd. for our business customers.

● *Efficiency* Our costs have to be low in comparison with those of our competitors, and low costs are essential to produce competitive prices.

● *Priorities* BT's network is huge and will take some time to modernise and the new facilities offered by that modern technology must first be made available to those customers that need those facilities the most.

● *Information Technology* It is BT's aim to be a leader, certainly in the UK, in information technology. In the longer term, this will require profound changes in the architecture of the switched network that is already being installed, but I will tell you more about that later when I talk about the long-term objectives of BT.

## PROGRESS TOWARDS A HIGH-QUALITY/LOW-COST NETWORK

Let me turn to the progress made in achieving that high-quality and, we hope, low-cost network.

† Central, South West England and Wales Territory, British Telecom UK Communications

\* Federation of Telecommunications Engineers of the European Community

‡ JONES, P. C. Common European Objectives. *FITCE Revue*, Oct./Nov./Dec. 1987, p. 33.

Modernisation of the trunk network is virtually complete. The local exchange modernisation programme is also gathering momentum after a slow start, the problems being the familiar ones of interfacing the existing analogue systems with the new digital technology.

As well as reducing the number of processor sites, we are also upgrading the junction network with optical fibre, something you will all be familiar with in the future.

We are also at work reducing costs by concentrating the computer resources used for the administration of the network into a smaller number of sites. Our operator services are also being revamped.

If I turn now to public payphones, we are spending £160M to improve the payphone service and in fact all public call offices have had their mechanisms modernised by now; that is, the end of August 1987. There is also a programme to modernise the booths, but that will take a lot longer.

BT is also hard at work to turn the tide of public payphone vandalism, a problem that is not unique to the UK, and is very difficult to solve, but we are tackling it by initiatives with local communities and the introduction of cashless payphones.

Work is also underway to provide front office computer systems to improve the service we give to our customers.

#### **LONG-TERM STRATEGY AND INFORMATION TECHNOLOGY**

But what of BT's long term strategy? So far we are committed to redesigning and re-engineering the network. In so doing, we will be improving the infrastructure that supports the products that are sold over the network. In the future, more effort will be directed to producing a portfolio of information systems that will be supported by the modernised network. The development of those systems is important for two very good reasons:

- One is that they are vital for the loading of the network so that we can increase the return on our investment.
- They also provide a way of more deeply penetrating a wider market of information technology, which you may remember is our fourth ambitious goal, and will help us in both national and international markets.

At present, BT competes as the traditional provider of voice telephony and Telex and, quite frankly, mostly with business customers, although our main competitor Mercury is anxious to take some of our more lucrative residential customers away from us. However, the changes in infrastructure, in the long term, should enable us to compete as a provider of information systems and as a supplier of computer-based solutions to our customers' problems; that is, non-traditional services based around a redesigned network.

The investment planned for the network

will greatly increase its capacity, and the processing power within the network, and this should enable us to bring about a step change in the variety of services which the network can provide. If you like, the change in the architecture that we have to bring about will transform it into a set of massive computer-based systems that will provide the types of facilities that are presently only available at each end of the network.

This work will greatly improve the return on our investment. To do this, we need to consider four changes.

The first of these will be in the architecture of the basic network that we have. Work is already underway to establish the way in which the basic bit transport, messaging and data processing are to be handled.

The second will be in the exchanges. The way in which the switch will develop is already the focus of industry debate especially in America. The outcome will be of great importance for all network providers. The vital change required is that the software presently embedded in the exchange switch will be separated out so that control of the software, and how it is configured and the facilities it provides, will be immediately in the hands of the PTO. This means that the hardware could become dumb and commoditised, that is churned out cheaply, while the intelligence in the network will be provided by the software engineering architecture and the operational and commercial skills of the PTO. This is in fact the key to the cost-effective provision of a wide range of services provided by the network and, of course, should provide a quicker and greater return on our planned investment.

The third change concerns the problem of handling databases; their nature, their ease of manipulation and their accessibility all have a large part to play in the value of any computer-based system.

The final change is in the terminal equipment; that is, equipment for customers' and operators' premises, by which our customers gain access to the system. In order to maximise the loading of the network, a range of compatible equipment will be needed. The supply of that equipment should come from a variety of manufacturers able to compete fairly with each other across national frontiers. This would of course be difficult without common European standards, to say nothing just yet of tariff barriers.

The four changes that we are considering for BT's network are easily realised, or more easily realised perhaps I should say, in a liberalised market. I suggest that it must be difficult for a monopolistic PTO to think in terms of such a strategy when in fact there may be little competition or an excess of self-regulation.

Given those two extremes, what scope is there then for common objectives? We may

be provided with a clue if we look at what the European Commission (EC) Green Paper proposes and look at that in the light of the relative state of liberalisation that exists at the moment throughout Europe. The EC proposals envisage much greater competition throughout the community in order to stimulate new telecommunication services and to create a large unified home market for European suppliers.

## EUROPEAN PAPER ON TELECOMMUNICATIONS

There are about 11 main proposals which I will now consider:

- The complete opening of the terminal equipment market to competition.
- Competition in communication services.
- The right to provision of services across national frontiers in the community.
- The continuation of exclusive or special rights for administrations regarding the provision and operation of the network infrastructure.
- Clear separation of the regulatory and operational functions of the public or private networks.
- An opening up of the market in satellite earth stations, as long as they are identified as telecommunications terminals rather than part of the infrastructure.
- Recognition that telecommunication tariffs should follow cost trends.
- Development of a consensus by PTOs, traditional telecommunications suppliers and the new information technology providers to smooth the transitions and take maximum advantage of the development of networks and services to create new jobs. I think that is very important.
- Stimulation of economic development and reduction in the isolation of outlying regions of the community through telecommunications.
- Establishment of a common European position in the various international bodies such as GATT, ITU and so on. This includes the creation of a European standards institute to accelerate standards and specifications needed for an open and competitive market environment. I am pleased to have heard from Siemens that they, together with Plessey, Italtel and CIT Alcatel, are working together now to produce a common specification for components used in the network.
- The final proposal is the development of 'made in Europe' information technology services.

The proposals are far reaching and require fundamental changes to the way existing PTOs operate and, incidentally, in the way that they think, in particular in the way that their employees think. Something that BT has already had to face.

Although provision has been made to retain some monopoly supply of services beyond

1992, the days of the monopoly PTO look numbered, especially when you consider what Karl Heintz Narjes, Vice President of the European Commission, said when he introduced the Green Paper. He said, 'if Europe is to meet the challenges, it must be out of the question for existing national monopolies to be responsible for the entire telecommunications functions'.

## PROGRESS TOWARDS LIBERALISATION IN EUROPE

So what progress has been made towards liberalisation in Europe? If we look at the value added network services (Figure 1(a)), we can see that for most of our member states there is still some considerable way to go. Iceland (non-EEC) and the UK have the highest levels of liberalisation. There is a slight improvement perhaps with the communications services (Figure 1(b)) that bring us nearer to the proposals. Once again, Iceland and the UK are the most liberalised, but we can see that there are still a few countries that are yet to start the liberalisation process.

Terminal supply (Figure 1(c)) seems to be one area where some considerable progress has been made in liberalisation.

The overall index of deregulation (Figure 1(d)), which includes the liberalisation of the basic carrier services, shows the UK with the highest value, principally because of the duopoly with Mercury.

Changes that bring us closer to the proposals mentioned earlier are very much under discussion at the moment. In particular, I am thinking of France and Germany, who are expected to decide soon about their level of commitment to liberalisation. The Netherlands has already committed itself to some liberalisation to take effect at the beginning of 1989. These changes will involve the change to a private company NVPTT. There will be a loss of monopoly in the supply of terminal equipment and complete liberalisation of value added services. Nevertheless, the basic public network will remain as a PTO monopoly.

There is clearly still some considerable way to go for most PTOs to achieve the changes proposed in the Green Paper.

## SUPPLIERS

What about the suppliers? The main aim of the Green Paper was to produce a large unified European market and to stimulate services. The large unified market should enable our suppliers to compete effectively with America and Japan. Some of our European manufacturers are already competing successfully in international markets. These include Siemens, Ericsson, and Alcatel, which has now become the second largest in the world after AT&T. Siemens is making good progress into the American large-scale switch market. Mean-



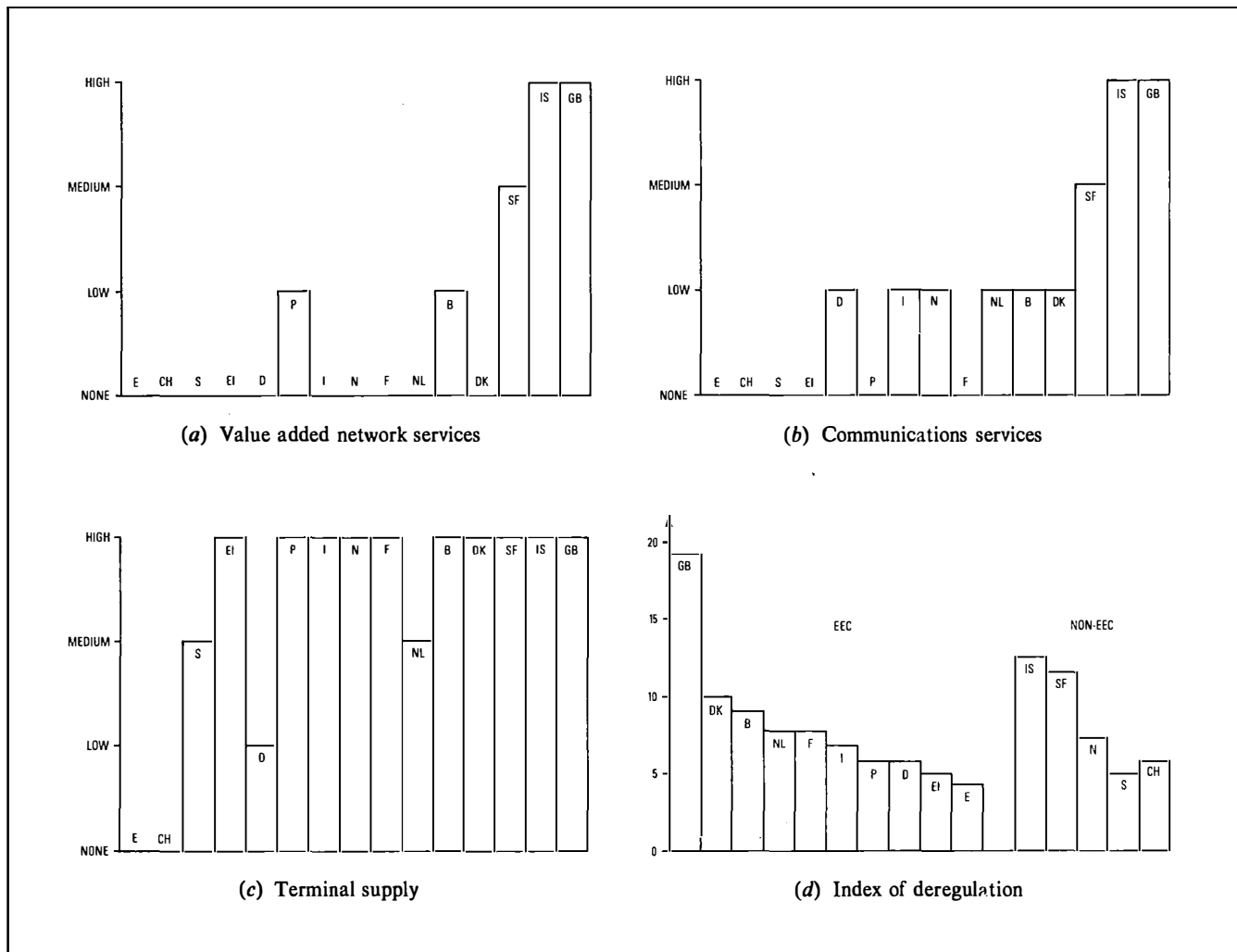

E: Spain  
 CH: Switzerland  
 S: Sweden  
 EI: Ireland

F: France  
 NL: Netherlands  
 B: Belgium  
 DK: Denmark

D: West Germany  
 P: Portugal  
 I: Italy  
 N: Norway

SF: Finland  
 IS: Iceland  
 GB: United Kingdom

Source: Pactel, December 1986

Figure 1—Progress towards liberalisation in Europe

while, our own STC and France's Cable de Lyon are also benefiting from the adoption of standards in Europe. While I am talking about standards, the recent decision to adopt a pan-European system of the digital cellular mobile radio telephones is a significant breakthrough towards common standards. This could contribute towards the establishment of a strong European manufacturing base, since the planned network should rival Japan or America in size. The market in Europe is expected to generate equipment orders worth about £600M per year by 1990. Intense discussions are now taking place between a variety of European manufacturers which should culminate in transnational joint ventures involving combinations of manufacturers including Motorola, Ericsson, Siemens, Matra

and Orbitel of the UK. The opportunities presented by the mobile telephone decision are small in comparison with the rich pickings that should stem from liberalisation, the European market being worth some \$22 billion. The important point here is that it is competition within Europe that has stimulated our suppliers into action. Competition has concentrated their minds but there are general problems. It has long been argued that manufacturing performance has been undermined by what we call *feather-bedding*. That is to say, manufacturers have had things easier than they would have had, had there been some competition in their own home market. The problem is also compounded by the frustrations of not being able to expand because of protectionism throughout Europe. Not that

protectionism is confined to Europe of course, the Japanese could teach us all something on the matter.

However, there is another handicap to overcome. The EC paper makes the point that the bringing down of trade barriers within the EEC will lead to the restructuring of European manufacturers into larger units. At least, that is the hope. They will by their sheer size be able to operate not only within the tariff-free EEC but they should be large enough to take on the might of the Japanese and the Americans in their own markets. Sadly, there is little history of EEC telecommunications manufacturers competing with each other in Europe. This puts them at a severe disadvantage compared with the Japanese and Americans who have to compete ferociously with each other at home. We need to see the scale of competition and collaboration that we have with the European Airbus Consortium, which is successfully competing in international markets.

## CONCLUSION

It can be seen that the planned removal of frontier barriers by 1992 will require a profound change in the way that PTOs think, and I would emphasise again that it is not just PTO management but also the employees that will need to think in a different way. That liberalisation will take place can not be doubted, but it is the pace of change and how it is implemented that is of vital importance. PTOs need to think about their future. For example, can their telecommunications systems provide enough added value to see them into the next century. Our suppliers and manufacturers must also seize the opportunities that the change will bring. Europe's

problems at present seem to be related to cultural differences within Europe. We have seen collaborations by member states with Sweden, Japan and America which seem easier than with other member states. It is European cultural barriers as well as those relating to regulatory issues that have to be broken down. Manufacturers need to have nationalistic self interest to be put aside in order for them to ensure that intra-European collaborations—that is, collaborations between EEC members—take place and succeed, to create both jobs and wealth within Europe rather than elsewhere.

EEC PTOs have many problems ahead of them. Many have already been faced with some degree of success by BT, although it has certainly not been easy. Let us ensure that we really do have common European objectives, for we shall need them if we are to survive as more than mere bit-carriers into the next century.

## Biography

Peter Jones joined the then British Post Office in 1967 as a Trainee Technician Apprentice, and studied for an honours degree in Telecommunications Engineering at Essex University. After graduating in 1973, he returned to the Liverpool Telephone Area as a technician on telephone exchange maintenance duties. In 1977, he was promoted to Assistant Executive Engineer and joined a team developing a distributed microprocessor based system for operator services. He was promoted to Executive Engineer in 1981 and worked on improvements to the TXE4 electronic exchange system. In 1985, he was promoted to his present position of Territory Switching Manager. His role is mainly one of monitoring the performance of Districts in the Central and South West England and Wales Territory, and recommending improvements which impinge on management and operational aspects of BT.

# Moling and Other Trenchless Techniques Used in British Telecom—An Overview

A. W. RENSHAW†

UDC 621.395.73

*British Telecom has employed trenchless techniques to install duct for over 60 years, with varying degrees of success. This article describes the telecommunications duct network, drawing attention to the factors which constrain a wider use of moling methods for its construction. There are, however, many situations where trenchless construction can be used and the article draws attention to present BT methods with special reference to moling.*

*The article is based on a paper presented at the NO-DIG 87 conference, and is published with permission of the International Society for Trenchless Technology.*

## INTRODUCTION

Trenchless techniques in British Telecom have traditionally been resorted to only when conventional trenching methods have been impractical on either technical or cost grounds. In the case of moling, a typical circumstance would be constructing a duct track under a trunk road when the disruption and safety aspects associated with trenching would be unacceptable.

A major constraint on the wider use of trenchless methods in other situations has been economic—a point which has been made several times at recent conferences on trenchless technology. Cost is not, however, the only constraint; the risk of damage to other subsurface plant is a very real problem, and, in the case of moling, it is only in the past decade that accuracy has become sufficiently improved to make this method acceptable.

## BRITISH TELECOM DUCT SYSTEM

Most BT cable is installed in duct and, where in the past BT has installed a certain amount of cable directly in the ground, the present tendency is to move to a fully ducted system. A ducted system has advantages in that cable is relatively well protected, and new and replacement cabling work can be carried out from jointing chambers constructed at intervals along a duct route without the need for excavation.

Telecommunications plant has a characteristic which makes it different from the piped services of other utilities in that the capacity of an underground route is increased incrementally by adding additional bores, and not by increasing bore diameter. This is because there is a limit to the number of cables which can be installed in a duct bore before cabling problems occur. See Figure 1.

† Network Systems Engineering and Technology Department, British Telecom UK Communications

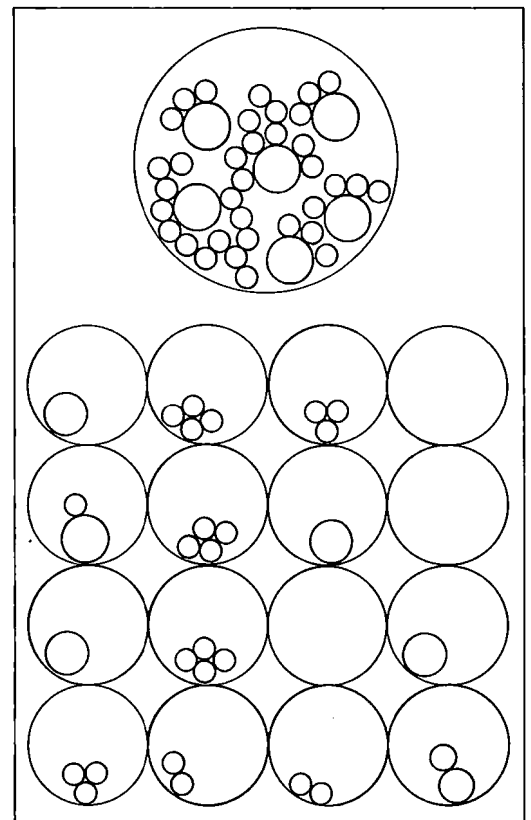

Figure 1—Illustration of problems encountered with large-bore duct system (top) compared with BT multi-bore duct system

The bulk of the duct installed up to the 1960s was earthenware, with plastic being first introduced in 1963. Both types of duct were purchased in parallel until the decision was made in 1980 to use only plastic duct for future work.

The sizes of duct mainly used now are Duct 54D, a 90 mm-bore PVC duct (104 mm outside diameter) for most routes, and Duct 102, a 27 mm bore polyethylene duct (34 mm outside diameter) for subscribers' leads-in. There is some use of an intermediate duct

size, Duct 56, a 50 mm bore duct (60 mm outside diameter) and other non-standard ducts, but the amount used is limited.

BT already has 400 000 km of duct installed in the UK. However, because of the nature of the telecommunications cable system, which has a 'tree-and-branch' configuration, a large percentage of this duct is installed in multiple-duct nests in heavily congested urban areas as the cable routes approach telephone exchanges. Many of these urban multiple-duct routes are between nine and 50 or more bores, and there are only some 186 000 route km of duct track, giving an average of about 2.2 bores/route.

BT generally prefers to lay duct under the footway or in grass verges; this has several benefits—depth of cover can be less than in the carriageway, safety of staff during cabling and jointing is increased, and obstructions to traffic minimised. However, in the often extremely congested underground environment in the urban areas or in rural situations when there is insufficient space, the duct route is placed in the carriageway. The standard minimum depths of cover to the top of the uppermost duct or the concrete surround to larger nests of ducts are (see Figure 2):

under the footway or grass verge 350 mm  
under the carriageway 600 mm

This characteristic multi-bore duct track is an important constraint in the application of trenchless techniques. When pipe jacking, mini-tunnelling and similar techniques are used, it is customary to fill the large bore with a number of ducts. In the case of moling, the provision of multi-bore installations can be problematical. If a large diameter mole is used to provide a hole in which two or three ducts can be provided, the penalty is that the bore must be fairly deep to avoid the mole rising or damaging the surface. If a small mole is used to construct a multi-bore track, then bores must be at some distance from each other to avoid damaging previously installed bores. Duct track is provided on the basis of a forecast requirement of duct space for twenty years ahead or more, and duct containing working cable cannot be disturbed without incurring considerable extra costs. Thus, unlike a piped service, oversize replacement cannot normally be considered.

### INSTALLING BRITISH TELECOM DUCT Installation by Contract

A large proportion of the work of installing duct is put out to contract on a competitive tendering basis and, although the work of installing large numbers of ducts could conceivably be carried out by trenchless techniques, these are frequently not applicable due to the proximity of other services in the area and the shallow depth of lay required. Even so, there are about 4000 installations where

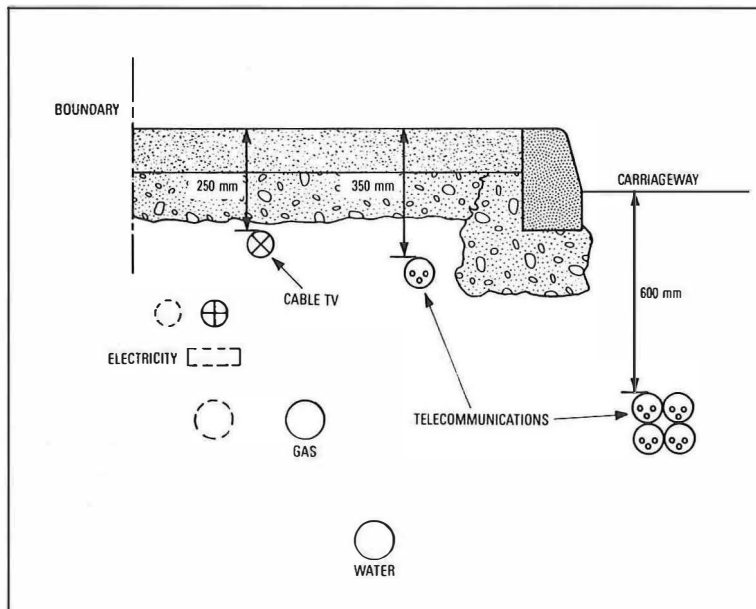

Figure 2  
Recommended  
positions of plant

timber-headings, mini-tunnels, pipejacking and auger boring techniques have been used to install parts of the BT system. In the majority of these installations, the large diameter bore or tunnel is filled with ducts and the remaining space filled with concrete.

### Installation by British Telecom

BT has always carried out a small percentage of its own ductwork. Wherever BT has carried out its own work, it has recognised the value of trenchless techniques and these have been used wherever possible. The work has normally had to be carried out by staff who conduct other work, so they are rarely specialists, and only occasionally carry out moling operations.

BT therefore has a requirement to obtain equipment to enable its own staff to lay duct and cable by trenchless techniques; for example,

- using moles for road crossings where trenching is impractical or moling is cheaper, leaving the contractors to carry out the main trenching work down the footways or carriageways;
- using moles to install duct routes under railways, canals and rivers where this proves economic or expedient;

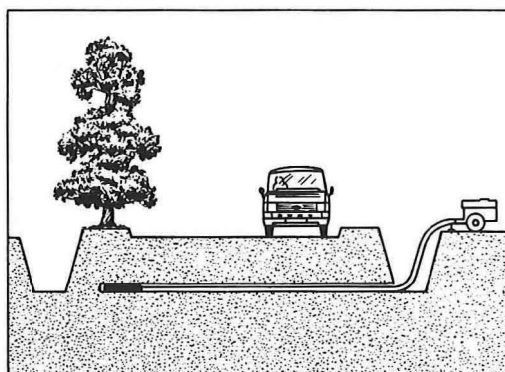

Figure 3  
Typical moling  
application

- using moles to install cable and duct where access is restricted; and
- using moles to install customers leads-in where it is not expedient or economic to disturb the surface.

As has been previously discussed, when moles are used for this type of work two particular problems are encountered:

- Moles cannot be used too near the surface, and as most BT duct is laid at a relatively shallow depth, this causes interface problems when standard jointing boxes are used.
- Moles cannot be used to lay ducts in close proximity to each other, and this causes problems where more than one duct has to be laid or ducts are to be added to existing duct routes, the situation for much BT ductwork. See Figure 4.

**Figure 4**  
Comparative operating depths of 65 mm and 115 mm moles

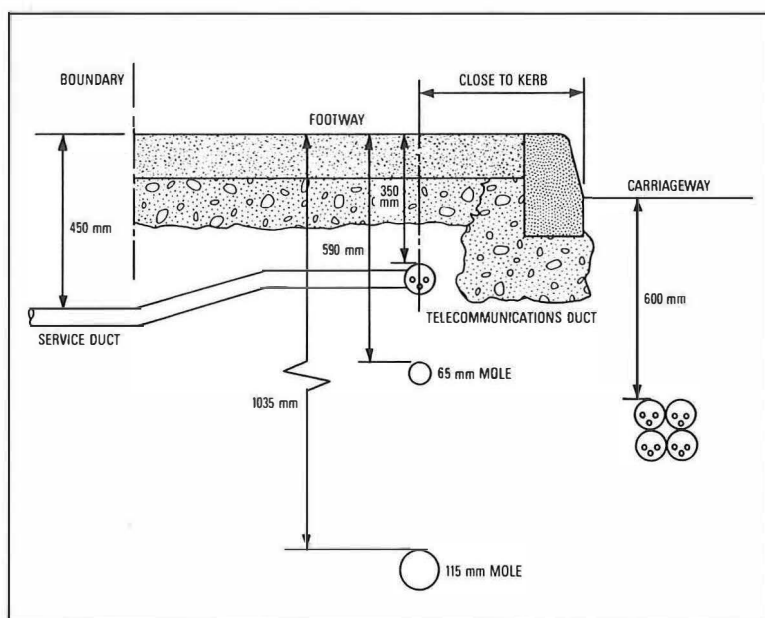

#### DEVELOPMENT OF TRENCHLESS TECHNIQUES IN BRITISH TELECOM

The earliest use of trenchless techniques was using hand-operated thrustborers during the First World War while providing pipes and cables under roads without interrupting traffic. After this, thrustboring began in earnest in the then General Post Office in 1923 with the purchase of numbers of hand-operated hydraulic machines and the later introduction of petrol engine-driven thrustborers. This provided very early experience of trenchless techniques within the business.

The requirements at the time were for two sizes of machine:

- A system for installing 90 mm duct under roads, railways, canals etc. This system was to be run from a large power source which was trailer or vehicle transported.
- A small 'lightweight' unit for installing cables, and later small bore duct, under cus-

tomers' driveways and gardens. This unit had to be capable of being easily transported and used by a small working party.

Both the above systems had to operate accurately and be able to penetrate most ground conditions, especially those found under roads.

#### Thrustboring and Other Techniques

The original thrustboring techniques were the earliest trenchless methods used and, although partly successful, they suffered from the following disadvantages:

- large heavy machinery,
- large accurate pits required,
- slow progress,
- easily stopped, and
- very easily deviated.

A variety of other techniques were tried out, including small auger borers and compacting augers, but these all had significant disadvantages and were all abandoned after trials and notable failures in the field. Water jetting was also discounted after the production of sub-surface voids when trialling high-flow-rate water-jetting techniques.

#### First-Generation Percussive Moles

The first attempts at using percussive moles were with the KRET, a Polish mole, in 1964. One of these machines was purchased and trials were carried out throughout the country. This was followed by a Magic Mole purchased in the early-1970s. Although these moles did penetrate the ground, they were unreliable and inaccurate. As a consequence, when trenchless techniques were required, the original thrustboring machinery continued to be used with all the problems associated with this method of working.

#### Second-Generation Percussive Moles

The second generation of percussive moles with stepped heads, whether fixed or moving, provided a range of moles in late-1973 which seemed at last to have solved a lot of the problems of very poor accuracy. The sizes available were, however, not suited to BT's needs, and, although some of the larger 130 mm moles were purchased along with large trailer compressors, the main product purchased was the 65 mm mole. These were only suitable for installing 60 mm duct, a non-preferred size.

Although the lack of suitably sized moles severely limited the use of moling equipment in BT for many years, both the 65 mm and 130 mm machines continue to be used effectively for many road, railway, and canal crossings. Some of the work installing ducts under airfield runways has involved bores of over 60 m.

## Modern Percussive Moles

BT is now able to purchase the moling equipment it requires in two sizes—a mole run from a BT standard trailer compressor which will tow in the larger ducts, and a lightweight kit for installing small duct to customers' premises. The first of the acceptable small-diameter moles became available as recently as 1984, and the larger mole only in 1986.

The large mole must be suitable for towing in duct up to 90 mm (Duct 54D and 56), and must be able to be run at full power from a BT standard trailer compressor giving 33 l/s at 7 bar pressure. This machine is purchased as a boxed kit containing all the accessories such as launch cradles and sighting frames, required to carry out a job, and a kit can then be drawn out of the stores by any trained party requiring to use it.

The miniature machine is provided to install 27 mm duct (Duct 102) to customers' premises, under drives, gardens and small roads. It is provided as a kit which includes a lightweight portable compressor suitable for powering the mole and this allows the unit to be easily taken out on site. Transport to site can be carried out by a party of two, so the compressor must be able to be lifted into a vehicle by two men. The provision of a lightweight, quiet, reliable compressor is thus seen as an important factor in the use of this kit, as it is frequently used in residential areas.

## STEERABLE DEVICES

BT, and probably most other utilities, would ideally like a device which is set up on the surface, digs its way down to the required depth, turns through 90°, burrows along to the required destination going straight through every obstacle unless it is another buried service, installing the required duct as it goes! At the present time and for the foreseeable future, this is likely to remain an ideal, although promising steps in this direction are being made.

A steerable water-jetting system recently developed would appear to be an important step along the way towards meeting this ideal trenchless system. The use and development of this system is being monitored and some trials were carried out during 1986 and 1987.

BT sees the advantages of this jetting technique as:

- steerable down to the required depth and around obstacles,
- able to be tracked while the job is in progress,
- appears not to damage other services,

- may be used relatively close to the surface, and
- may be used to place one duct alongside another,

and its disadvantages as:

- will not cope with certain ground conditions or ground containing large numbers of inclusions,
- the equipment initially used in the UK was too large for many situations (although more compact equipment is being produced), and
- the equipment is expensive for direct labour use and there may be difficulties in scheduling work to give an economic workload for a specialist contractor.

## THE LEGACY OF ALL THIS EXPERIENCE

BT staff have a long history of awareness of trenchless techniques and their use. However, the development of trenchless tools has involved many setbacks, with many contractors having been reluctant to adapt to trenchless techniques and damage being caused to BT plant by other utilities or contractors using trenchless techniques. With this legacy, it is perhaps understandable that there remains a cautious attitude in BT to the use of trenchless techniques by direct labour.

As the amount of ductwork carried out by direct labour is relatively small, and will continue to be so, BT will continue to let the large part of the installation of its ducts out to contract on a competitive tender basis. However, the business looks forward to the increasing professional use of the full range of trenchless techniques by contractors to reduce all the costs involved in carrying out this work.

No doubt as trenchless techniques improve in both economic and performance terms, there will be an increasing use of these techniques within BT, but, as has been explained in this article, there are real constraints to be overcome which, as far as can be foreseen, will restrain a dramatic increase in their application to BT work.

## Biography

Tony Renshaw joined the then British Post Office in 1973 after obtaining a degree in Mechanical Engineering at Liverpool University. Engaged initially on the design and specification of small mechanical aids, he then spent a period working on the mechanical handling of exchange equipment. After a period working on the design of vehicular mechanical aids, he took up his present position as installation methods engineer dealing with the design and specification of the plant and associated practices for the burial of cable and duct by direct labour and some cabling systems.

# Product News

## British Telecom Launches Poet—A Manager/Secretary Communications System

BT has announced the launch of Poet, a two-line two-extension telephone system specifically designed to serve the needs of the manager/secretary combination.

The Poet communication system consists of two sleek and compact telephone terminals, approved for use on a large number of compatible BT PBXs, which plug in to existing extension sockets and are simply linked by a pair of wires. In addition to this, a plug-in mains power unit is supplied. As the system is specifically designed for use on PBX extensions and not on direct exchange lines, it has no inherent switching capability. However, a simple single-button operation is all that is necessary to access the host PBX.

The Poet telephone system offers a wide range of special features to assist and increase the efficiency of the manager/secretary team. The multi-button key telephones work only in pairs and are identical in appearance, facilities and operation except for an additional DO NOT DISTURB button on the manager's terminal, which eliminates interruption from incoming calls or the intercom. Each of the terminals can make and receive calls and feature loudspeech and intercom facilities. A powerful microphone and built-in loudspeaker enables handsfree working, particularly useful when taking notes of conversations.

Other features of the system include call transfer, call hold, divert and conference facilities as well as automatic recall for engaged numbers and repertory dialling. A 20-number memory store is accessed through a simple one-button operation. Poet can also be programmed to provide single-key access to other commonly used facilities on the central keyboard.



BT's Poet—a new two-line two-extension featurephone system for the manager/secretary combination

Programming is simple and no complicated coding is necessary. Security is ensured with a battery memory back-up in case of power failure. The liquid crystal display on each terminal provides an 'at a glance' check on all numbers dialled and numbers stored as well as a 'battery low' signal.

## X.400 for DEC Users

BT has launched an X.400 electronic messaging system for DEC VAX minicomputers. TX400-VP is a standalone package designed for use on any VAX-based system. It provides the framework for a world-wide corporate electronic mail network, irrespective of the type of computer used.

As a vendor-independent software supplier, BT has developed the TX400-VP, an X.400 messaging system designed to run under VAX/VMS. The package is a more effective solution since it is not incorporated into a larger and more costly proprietary office automation system. It is expected that demand for the system will come from large organisations with the need to communicate across both national and international networks. Typically, these would be companies involved in finance, retail, manufacturing, travel and insurance.

TX400-VP has been developed by the British Telecom Software Centre in London and conforms to the international CCITT X.400 standard, which is the electronic messaging application of the Open Systems Interconnection (OSI) model. Once installed, under the DEC VAX VMS operating system, users will be able to communicate with any other X.400 messaging system irrespective of the make or model of computer concerned.

X.400 has already been embraced by the major computer

suppliers, who have announced the intention to supply X.400 systems.

As the first supplier of the X.400 system of its kind for DEC users, BT is able to offer an independent software solution for world-wide corporate communications networks. Through existing expertise and participation in developing international standards of both computers and data communications, BT is committed to the supply of 'Open Systems' and the provision of alternative solutions for corporations locked into single-vendor systems.

The messages TX400-VP will transmit need not be confined to standard ASCII text, since binary files are also accommodated by the system. This allows graphics, images, programs and data files to be sent. Compatibility with BT's GOLD 400 public electronic mail service provides PSTN dial-up access, and includes fax and Telex.

Delivery and receipt of messages is driven by BT's recommended user interface which offers both pull-down menus and windowing techniques for ease of use. An advanced virtual terminal interface allows portability to a variety of terminals. The system is divided into a user agent (UA) for interpersonal messaging and a message transfer agent (MTA) for the physical transfer. The user is advised of delivery and receipt of messages.



# British Telecom Press Notices

## Ultra-Modern Control Centre for London's Network

A futuristic control centre for its modern digital network in London, which BT formally opened on 16 September, has the world's most advanced facilities for pin-pointing potential trouble spots and taking swift action before service to customers becomes affected. The site, in the heart of the City, is linked to a national control centre in the Midlands which performs a similar role for BT's growing digital network nation-wide.

Maps and other displays present staff sitting at consoles with a continuously updated picture of the state of the network, showing the flow of calls through it. On adjacent screens, TV programmes are continuously monitored to check for telephone numbers flashed on to screens. The facilities give early warning of a possible flood of calls to a particular number, to enable staff to act immediately to protect the network, and re-route other calls to by-pass congested areas. In this way, intermediate exchanges and inter-exchange links are kept as free as possible for calls to other destinations, and ensure a high probability that calls to the advertised numbers will be successful. Faults on exchanges, damage to cables, or other conditions affecting the availability of the network can also be quickly diagnosed, so that staff can reconfigure the network and re-route calls as far as possible around the affected location.

Commenting on the new London centre, Mr. Brian Haigh, BT's Director for London and the South East, said: 'This centre, and the control over the network that it gives us, is a direct result of our huge £1 billion-a-year modernisation programme under which we are installing an average of two digital exchanges every working day.

'Each digital exchange is controlled by a computer-like device called a processor. This has its own performance-

monitoring system and contains statistical data of calls made, their destinations and duration.

'This network-usage data is of great value for network planning. It allows managers to spot routes on which call growth is likely to outstrip capacity, so that early action can be taken to provide extra equipment in good time.

'This data is available only as a result of modernisation. The old electromechanical exchanges operated in isolation; each was responsible for checking its own operation and the condition of the lines connected to it. There was no overall picture of the state of the network, except in retrospect.

'British Telecom not only designed or specified all the systems used in the centre; it has implemented them faster here than anywhere else in the world.'

BT's modernised digital electronic network is already more comprehensive, in comparative terms, than that of any other national operator. The long-distance digital network has been fully in place for nearly a year. Its 53 large System X trunk exchanges are in service (including 10 in London), and supplying data on their operation to both the national and London network management centres. BT is now rapidly phasing out all its electromechanical trunk exchanges, and transferring the long-distance calls they handle to the digital trunk network. The process is expected to be completed by the end of March next year. In addition to the trunk network and its switches, BT now has nearly 1300 local System X and AXE10 digital exchanges with more than 4 million lines in public service. All will be monitored at the national centre. The London centre monitors those in London—currently totalling 37 processors, serving 127 switching units—plus the seven System X tandem exchanges in the capital switching calls between those local exchanges.

## Optical-Fibre Breakthrough

A technique which can increase the call-handling capacity of existing optical fibres at least ten-fold has been announced by BT. This means that fibres carrying up to 7500 calls at the same time could be capable of carrying 75 000 or more conversations.

The company is the first in the world to demonstrate coherent optical transmission over the operational network, outside the laboratory. Whereas previous demonstrations of coherent transmission have been made on the laboratory bench or under other controlled conditions, these trials are the first to be made over an existing optical-fibre cable, in this case more than 170 km long and without any intermediate signal amplification.

The success of this operation offers the real opportunity to establish direct fibre links, of virtually limitless capacity, between cities as far apart as London and Birmingham. It will also lead to future improvements in the overall reliability and message capacity of the BT network. Growth of telephone and data calls in particular (currently 7% per annum) could be met by installing new coherent transmission equipment re-using existing cables rather than having to provide additional complete systems alongside existing ones at a much higher cost.

Existing optical-fibre systems can carry up to 7680 conversations or data calls, but these systems still waste most of

the capacity of the fibre medium. They transmit on many wavelengths at once. By comparison, the new fourth-generation optical system, which has been demonstrated and must now be refined, can split the frequency spectrum in a fibre and send different groups of messages on separate wavelengths. At the far end, the receiver filters and sorts out the different communications channels, without interference or crosstalk.

In this way, the capacity of fibres can be increased dramatically. BT is still pioneering this technology and many options remain to be tested and proven, so it will be a number of years before customers have the full benefit of coherent transmission.

In the test, digital test equipment was used to simulate calls and count bit errors, rather than using live messages. The 176 km route ran from Cambridge – Bedford – Cambridge – St. Neots – Cambridge. Cambridge and Bedford were chosen as terminal points, to make use of spare fibre capacity temporarily available. The system operated over conventional installed single-mode fibre and used miniaturised long external cavity (LEC) lasers, a laser amplifier as an output stage to the transmitter and automated endless polarisation control at the receiver. The LEC lasers emit around the 1.55  $\mu\text{m}$  wavelength, with a typical spectral linewidth of 50 kHz.



## British Telecom's Public Telephone Revolution

On 25 August, BT unveiled its plans for Phonepoint—a revolutionary public telephone service based on a new generation of cordless telephones, known generically as CT2. The planned service would allow users of CT2 cordless phones to make calls from a network of Phonepoints situated in busy public locations. They would also be able to use the same phone at home and in offices equipped for it. But they will also, from launch, be capable of accepting handsets designed to a new standard now adopted by all CT2 phone manufacturers and known as the *common air interface* (CAI). This will ensure that all CT2 phones made in the future to the new standard will work with BT's Phonepoints.

Commenting on the new standard, Mr. John McMonigall, Managing Director of BT's International Products Division, said: 'The adoption of a new standard by all manufacturers of CT2 cordless phones is a major achievement which will bring many benefits to users. It means that any of the new phones will be compatible with the competing networks which will be licensed to operate with them.'

'BT's International Products Division is investing many millions of pounds in a project with STC to develop and produce a CT2 phone conforming to CAI. As a result of this investment, both companies were able to make a valuable contribution to the discussions with fellow manufacturers

during the last three months in which agreement on CAI has been reached.

'The agreement strengthens the UK's world lead in second-generation cordless phone technology. It opens the way for international adoption of the UK's CT2 standard.'

In July, the Department of Trade and Industry (DTI) announced that it would issue licences for Phonepoint-type services to up to four national network operators. BT has confirmed that it is to apply for a licence, and if successful will launch its Phonepoint service next spring. Phonepoint would initially be available in London and the Home Counties and then be extended progressively throughout the UK during the next two years.

BT has outline agreements for Phonepoint locations with a number of potential site owners, including a national garage chain, a motorway service station firm, public houses and a number of shopping centres.

BT is already conducting tests for the Phonepoint service, and plans a limited public trial of the full service, including the billing system, later this year. CT2 telephones will operate up to 100 m from a base station.

BT expects to have CT2 cordless phones to the new CAI standard available in 1990. But it will ensure that purchasers of current generation CT2 products would continue to be supported alongside CAI products.

## Major Computing and Communications Companies Form International Association

Eight major world-wide players in computing and telecommunications have come together to accelerate the introduction of network management products capable of operating with each other.

This initiative will benefit businesses by improving their ability to manage the networks they use to transport and access both voice and data information. These networks carry telephone calls, computer data, facsimile messages—the very lifeblood of their businesses. By simplifying network management, customers can devote more of their resources to profitable business activities.

The eight companies—Amdahl Corporation (California), AT&T (New York), British Telecom (UK), Hewlett-Packard Company (California), Northern Telecom (Tennessee), Telecom Canada (Ottawa), STC plc (UK), and Unisys Networks (New Jersey)—have formed the OSI Network Management Forum (OSI/NM Forum). This open forum will base its work on the international standards model known as *Open Systems Interconnection* (OSI).

Speaking for the Forum, Brian Hewat, director of Telecom Canada, spelled out the benefit of its work for users: 'Many companies today operate integrated computing and communications networks that combine the products and services of different vendors. They invest thousands, often millions, of dollars in these systems and networks each year. It is critical to their business success that these diverse systems work together efficiently.'

Network management is the ability—through hardware and software systems—to identify, monitor and control network reliability, configuration, security, accounting, and performance.

'This is where the Forum can bring real benefits to customers,' Hewat said, 'Its members are committed to ensuring that their network management products and services can work together—and do so as quickly and as comprehensively as possible.'

Hewat said that Forum members have pledged that their companies will implement existing OSI standards, as well as contribute to the further development of those standards.

'But some aspects of OSI still need to be fully worked out. But we need to find a means to address customers' network management needs now,' he said. 'And we must ensure that any solution allows them to move easily to the final standard.'

'The principal task of the Forum will be to supply the specific implementation information, such as protocol options and message sets, that designers now need to develop products that fit together with those of other vendors. This is a natural extension of the contribution Forum members already make to standards committees.'

The Forum's first effort will be to agree upon a set of network management options within each of the seven layers of the OSI model. Vendor members will then have the opportunity to implement these options with the objective of demonstrating inter-operability in customer networks in about 18 months. The Forum's work could reduce product delivery times by as much as two years.

Hewat concluded: 'The Forum serves as a facilitator; it will not itself be creating any products. Responsibility for developing inter-operable network management products will continue to rest with each vendor.'

## British Telecom Office Automation will Boost Efficiency

Major savings will be made by BT during the next decade after its decision to introduce office automation throughout the company. The programme will be one of the largest distributed office automation schemes in the world, and is expected to cost between £25M and £30M a year to implement during the 1990s. Known as the *Common Office Automation System for Telecom* (COAST), it will have more than 60 000 users within the company throughout the UK and world-wide.

COAST will use BT's own supermicrocomputers made in Birmingham by its subsidiary company Fulcrum Communications linked to, and eventually replacing, the variety of small computers and local networks at present used. It will provide BT's managers with electronic mail, word processing and diary scheduling at their desks, combined with a local computing facility. This will allow users to process and exchange data, text and graphics information of all kinds rapidly and effectively. It will significantly improve the communications and administrative efficiency of BT's internal operations, and will benefit BT's customers and suppliers by minimising delays and by providing managers with up-to-date and accurate information.

COAST will use UNIPLEX office automation software provided by Uniplex Ltd. of St. Albans running on BT's M6000 range UNIX machines plus its M5000 personal computers and M1779 terminals. Systems made by Nixdorf and Honeywell Bull to meet the performance range and security requirements are also being considered. This equipment will be interconnected by the company's T-Net local

area networks which in turn will be linked to its public packet switched data network.

The system would enable a manager working on a project in Leeds, say, to access information held in a BT office in Brighton, send electronic mail to Aberdeen, or perform any of the myriad functions available through consistent office automation.

COAST will play a major role in BT's migration away from systems and architectures based on proprietary standards. It is now going all out for networks complying with standards for Open Systems Interconnection (OSI) and for departmental schemes based on UNIX. It is estimated that, as a result, BT will cut its computing system procurement costs by at least 10%.

As the first step towards implementing COAST, managers will now start preparing detailed schemes for its introduction in each of BT's 28 Districts, and in the headquarters departments of BT's UK Communications Division. It is then expected that implementation will start next year and continue progressively throughout the 1990s, and embrace other operating divisions.

BT already represents 10% of the UK's information technology market, and it is BT's policy, as part of its drive to increase market share, to sell what it uses itself. In consequence, BT intends to bring COAST to the market place later this year to meet the growing demand, from both public and private sectors, for distributed office automation systems linked to different computer equipment in an open and secure network.

## Automated Manufacturing Data on Line

An extensive database on advanced manufacturing technology is to be made publicly available by BT's Dialcom Group as part of its PASSWORD suite of services for industry.

The database was originally set up by the Institution of Electrical Engineers (IEE) to support its activities as an information centre under the Department of Trade and Industry's programmes for computer-aided design, manufacture and test (CADMAT) and computer-aided design and computer-aided manufacturing (CADCAM). It was used in-house by the IEE to assist it in dealing with members' enquiries. As a result of agreement between the IEE and Dialcom UK, the database is to be made available on the Dialcom Group's electronic mail and database service Telecom Gold.

Known as *PASSWORD Advanced Manufacturing*, it will augment the growing range of database and transaction services available for the manufacturing and engineering industry in the PASSWORD repertoire. It will comprise product news, orders and installations, market and financial reports, reviews and technology updates drawn from more than 70 publications and other sources.

PASSWORD Advanced Manufacturing will focus primarily on computer-aided and automated processes, including computer-aided design (CAD), computer-aided manufacture (CAM), computer-aided production management (CAPM), computer-integrated manufacturing (CIM), computer-aided process planning (CAPP), materials requirement planning (MRP and MRPII), flexible manufac-

turing systems (FMS), 'just-in-time' (JIT) and its Japanese equivalent Kanban.

It will also cover standards development, such as the manufacturing automation protocol (MAP), technical and office protocol (TOP), electronic design interchange format (EDIF), initial graphics exchange specification (IGES), graphics kernel system (GKS), and the production design engineering specification standard for exchange of product data (PDES/STEP).

Several thousand companies of varying sizes are already represented on the PASSWORD database, covering both users and suppliers. Key CADCAM suppliers include Aarque Systems, Autodesk, Computervision, Cadnetix, Daisy, GE Calma, IBM, Mentor Graphics, and Sun Microsystems. Major electronics component suppliers on the PASSWORD database include Marconi, Ferranti, Lattice Logic, European Silicon Structures, Philips Components, Racal and Schlumberger.

PASSWORD Advanced Manufacturing is accessed through Dialcom's Telecom Gold service using a personal computer and modem. Two versions of the database will be available to promote access by the widest possible audience. One is teletype (TTY) compatible line-by-line scrolling version which will allow all existing Telecom Gold users access with no change required to their existing communications software. The other version is aimed at existing users of PASSWORD databases. This is designed to run on terminals with VT100 emulation, giving better screen layouts, including highlighting and reverse video.

## £200M Extension for Fibre Network

Business worth more than £200M is to be placed with Britain's telecommunications industry during the next few years to extend BT's optical-fibre network to the country's principal centres.

This extension will provide the nation's business community with the most advanced communications network of its kind in the world. It will further establish Britain as a leader in the range and quality of telecommunications services available commercially.

STC Telecommunications and GPT—GEC Plessey Telecommunications—are already supplying equipment to BT for the first phases of the network serving the City of London and the Docklands. They have, after intense international competition, been selected as suppliers for its nationwide extension, and will each receive orders worth more than £100M.

The network, known as *Flexible Access Systems* (FAS), provides optical-fibre cable links direct into customers' premises. It brings immediate advantages: fast supply of new circuits, better quality of transmission, prompt circuit reconfiguration and high reliability with rapid maintenance. FAS is already in use in the £70M City Fibre Network, initially serving 100 or so users in BT's Dealerinterlink, set up for financial customers in the City of London.

Next year, this network will be expanded to serve up to 600 customers in the City, with a further expansion to London's docklands development. In the third phase of the project, the network will be extended between 1990 and 1995 to other parts of London, and to Birmingham, Bristol, Edinburgh, Glasgow, Leeds and Manchester, and then to the rest of the UK.

In its earlier phases, FAS was intended primarily to speed the provision of private circuits. In this third extension, however, FAS will be developed to exploit its full potential and provide customers with access to the full range of services. These include BT's public dial-up telephone network, and the public data network as well as private circuits. This facility will later be provided on the City and Docklands networks now being introduced.

For this extension, both suppliers will utilise service access switches based on GPT's System X design. The network terminations—known as *customer service modules*—will be provided by a new GPT multiplexer and by a product jointly developed by STC and Northern Telecom.

The key elements of FAS are:

- a network of single-mode optical fibre,
- flexible software-controlled network terminations on customer premises, including primary multiplexers, higher-order multiplexers and opto-electronic fibre terminations—the customer service module (CSM),
- a digital service access switch (SAS) handling both analogue and digital private circuits, and

- software to monitor and control the hardware and to interface with BT's existing operational computer systems.

The cable network is dimensioned and installed at the outset to avoid constant piecemeal addition. In the CFN, it has been provided to sites where customers already have 25 circuits or more.

The principal network involves 96-fibre cables branching down to 48 and 24 fibres, the latter leading to joints serving a number of customer sites. Customer-entry cables usually have two or four fibres.

The network links CSMs on customers' premises to the service access switches. These are System X-based cross-connect switches providing both the connections needed for private circuits, and access to other services.

The initial CFN network has one 2048-port SAS to which initial users are connected. This will be increased by a further three switches of the same size to serve more than 1000 customers, and three more will be added to serve the docklands extension.

Optical fibres from customers will be linked to these switches, which are being interconnected by additional cabling. All told, the City and Docklands networks will use approaching 100 000 km of fibre, and this will be multiplied many times in the phase 3 extension of FAS.

The FAS link to customers acts as a common bearer for all services, and interfaces with the relevant equipment customers use, such as telephones, PABXs, dealer boards, data terminals. It will provide primary rate access, known as *multiline IDA* (integrated digital access), to BT's growing ISDN. This access is at 2 Mbit/s, to serve digital PBXs, which will then be connected to a 2 Mbit/s port at a local digital exchange. BT has now many thousands of these ports available. Signalling between the PBX and the exchange will use BT's Digital Access Signalling System No. 2 (DASS2).

Identical 2 Mbit/s links will also be used to provide dial-up analogue access. Customers' individual analogue circuits will be grouped onto one or more primary 2 Mbit/s multiplexers. The signalling interface will be a future development of the ISDN version of DASS2.

The 2 Mbit/s access links available on the fibre also support digital private circuit services. MegaStream, at 2 Mbit/s, is simply carried on the bearer to the SAS. Other services—KiloStream at up to 64 kbit/s, or speech band, are also grouped on the primary multiplexer and routed to the SAS.

Initially, a separate control centre provides continuous surveillance of the network electronics both for faults and error-rate degradation. It also enables private circuits to be set up between users on the system, or reconfigured, at will. In the longer term, FAS control is likely to be integrated with other, established, BT control centres.

## IBTE London Centre Information Service

For programme details,  
forthcoming events and  
general enquiries, telephone 01-587 8258

# Notes and Comments

## BT NEWS MISCELLANY

IN July, British Telconsult, the consultancy arm of BT, announced three major new overseas contracts worth a total of more than £1.5M. The first, a £1M World Bank funded project, is for a 12-month study, starting in August, to improve the management structure and organisation of the Kenya Posts and Telecommunications Corporation (KPTC).

The second contract, worth £150 000, is to provide specifications and evaluate tenders for a new telecommunications network for the Gulf Oil Company of Nigeria's office and housing complex on the Lekki peninsula in Lagos. The contract is with Gulf Affiliate, Chevron Petroleum (UK) Ltd., and covers the specifications for a fully integrated network incorporating data systems, microwave, satellite and mobile radio links operating inland and offshore.

The third contract is for British Telconsult to design, specify and supervise the installation of a rural telecommunications network in the Dhofar Region of Oman. The 20-month contract, worth approximately £400 000, is with the General Telecommunications Organisation of Oman. It provides for a fully digital main network including exchanges, microwave radio and optical-fibre links, together with associated local networks. British Telconsult successfully carried out a similar project in the Salalah Region two years ago.

BT has announced that it is investing £4M to provide a range of new networked services especially designed for use by local government. In particular, BT is putting at local authorities' disposal its wide-ranging telephone billing experience to assist them in collecting the community charge in the most cost-effective manner. The new service would enable local authorities to raise the community charge from residents quickly and efficiently without incurring the cost of setting up their own organisation for producing and despatching bills and reminders, collecting non-cash payments and keeping payment records.

In addition, BT is offering local authorities a purpose-designed electronic messaging service to facilitate the exchange of information between them. It has already set up Computer Standby, a fall-back service to safeguard local authorities against failure of their ICL computer systems. To complete a quartet of new services, BT has developed a networked system based on its M6000 UNIX supermicro-computer to meet the particular needs of trading standards departments. This covers office automation, trader database creation, and communications links with the Trading Standards National Information Service, Telecom Gold and other services.

BT has signed a collaborative agreement with the CAPITA Group Ltd. to form a new company that will offer a range of computer services, products and facilities management to the public sector. The new company, TELECOM CAPITA Ltd. will be based at CAPITA's Information Technology Centre in Birmingham.

BT has announced that it has placed orders worth more than £85M for a further 729 000 lines of digital exchange capacity as part of the company's £2.4 billion a year investment supporting its network modernisation programme. Most of the orders are for System X exchanges and are part of the agreement reached earlier this year with GEC Plessey Telecommunications (GPT) for the supply of this equipment to BT during the current financial year. These orders bring

the cumulative total of digital exchange capacity ordered by BT to more than 11 million lines, of which more than 5.5 million have been accepted from the suppliers, and nearly 4 million are available for service.

BT has been awarded three key Government contracts worth a total of £14M to provide up-to-date digital communications systems at army and navy sites. The new equipment is part of the most comprehensive peacetime upgrading of defence communications, and will provide high-performance telephone and data transmission facilities, independent of the public system. The orders complement earlier contracts won by BT for the RAF (£130M) and for the British Army (£13M), and includes the use of a System X exchange, the first time this equipment has been incorporated into a large private network.

Under the contracts, BT will replace manual switchboards and old-technology automatic branch exchanges with the latest 'smart' digital call-connect systems, to be supplied by GPT. The contracts also call for many MegaStream and other digital private circuits, as well as new press-button telephones. BT will also provide continuing maintenance under separate contracts, and is setting up special national fault reporting centres at Reading, for the army, and at Exeter, for the navy.

A consortium of information technology specialists led by BT is one of two suppliers chosen by the Ministry of Defence for the next phase of its multi-million pound office automation system. Known as the *Corporate Headquarters Office Technology System* (CHOTS), the system will be installed during the 1990s and will eventually serve 24 000 users in more than 40 MOD buildings throughout the UK. Other members of the BT consortium are Secure Information Systems Ltd., Honeywell Bull Ltd. and Nixdorf Computer Ltd. The consortium was one of four selected last year by the MOD to bid for the provision of prototype schemes. The latest award is for a prototype system for installation in January 1990. After an evaluation period, a final choice of supplier will be made.

BT is opening two new directory enquiry centres in the North East of England to handle queries from London customers 250 miles away. This long-distance approach to improving standards of the London directory enquiry service and meeting unprecedented demand will create another 80 new jobs. The first will open in Darlington in November 1988, followed in spring 1989 by the second centre in Durham.

BRITISH Telecom (CBP) Ltd, a wholly owned subsidiary of BT and manufacturer of high-technology dealing systems for financial traders and advanced call reception systems, has succeeded in meeting the stringent international quality standard, IS 9001 (BS 5750 Part 1:1987). The standard recognises the quality assurance procedures at every stage in the life of a product from design and manufacture to installation and customer support. CBP is the third part of BT to meet the standard. IS 9001 is the highest recognised international standard of quality assurance. Until recently, it was applied only as a UK national standard—BS 5750. Still administered by the British Standards Institute, it has now been adopted by 18 industrial countries including the US and Japan.

BT has contributed a quarter of a million pounds to a project to encourage the use of information technology in schools. Matched by a similar amount from the Department of Trade and Industry, the money will be used to provide secondary schools, independent schools, and initial teacher training establishments throughout the country with an extra telephone line, to be used for data communications. Using the line and a suitable modem, schools will be able to access the range of databases and data services that are now available, to provide information covering the whole curriculum. In addition, children will gain hands-on experience of the services which are very much a part of modern business life.

BT has announced the launch of a new Videoconferencing Centre in the Holiday Inn Crowne Plaza Midland, Manchester. In an agreement between the two companies, BT has installed its videoconferencing facilities in a fully-equipped meeting room, to offer users the latest in videoconferencing communications technology. As with BT's 10 other Videoconferencing Centres throughout the UK, the facilities at the Holiday Inn Crowne Plaza are available for rental on a half-hourly basis. This enables users to have face-to-face meetings in full sound and vision with groups of people at other Centres and private rooms, both nationally and internationally.

BT has appointed Mr. Richard Marriott to be its first Director of Strategic Relations. Reporting directly to BT's Chairman Mr. Iain Vallance, Mr. Marriott will be responsible for developing the relationships between BT and other key organisations and companies within the world telecommunications and information services industries.

LANDIS and Gyr has supplied BT with the 50 millionth Phonocard, which was presented to Michael Bett, Managing Director UK Communications, at a reception in London in September.

#### **PUBLICATION OF CORRESPONDENCE**

A regular correspondence column would make a lively and interesting feature in the *Journal*. Readers are therefore invited to write to the editors on any engineering, technical or other aspects of articles published in the *Journal*, or on related topics. Letters of sufficient interest will be published under 'Notes and Comments'. Letters intended for publication should be sent to the Managing Editor at the address given below.

#### **CONTRIBUTIONS TO THE JOURNAL**

Contributions of articles to *British Telecommunications Engineering* are always welcome. Anyone who feels that he or she could contribute an article (either short or long) of technical, managerial or general interest to engineers in British Telecom and the Post Office is invited to contact the Managing Editor at the address given below. The editors will always be pleased to give advice and try to arrange for help with the preparation of an article if needed.

#### **Educational Papers**

The Editors would like to hear from anyone who feels that they could contribute further papers in the series of educational papers published in the *Supplement*. Intending authors should contact the Deputy Managing Editor, at the address given below. An honorarium would be offered for suitable papers.

#### **Guidance for Authors**

Some guidance notes are available to authors to help them prepare manuscripts of *Journal* articles in a way that will assist in the uniformity of presentation, simplify the work of the *Journal's* editors, printers and illustrators, and help ensure that authors' wishes are easily interpreted. Any author preparing an article is invited to write to the Managing Editor, at the address given below, to obtain a copy.

All contributions to the *Journal* must be typed on one side only of each sheet of paper. As a guide, there are about 750 words to a page, allowing for illustrations, and the average length of an article is about six pages, although shorter articles are welcome. Contributions should preferably be illustrated with photographs, diagrams or sketches. Each circuit diagram or sketch should be drawn on a separate sheet of paper; neat sketches are all that is required. Photographs should be clear and sharply focused. Prints should preferably be glossy and should be unmounted, any notes or captions being written on a separate sheet of paper. Good colour slides can be accepted for black-and-white reproduction. Negatives are not required.

It is important that approval for publication is given at organisational level 5, and authors should seek approval, through supervising officers if appropriate, before submitting manuscripts.

#### **JOURNAL DISTRIBUTION—NOTIFICATION OF CHANGES OF ADDRESS**

IBTE Members and *Journal* subscribers who change their home address should ensure that they notify the *Journal* office on the address-label slip provided with every copy of the *Journal*.

All enquires related to distribution of the *Journal* should be directed to The Administration Manager at the address given below.

#### **BTE JOURNAL/IBTE ADMINISTRATION OFFICE**

All correspondence and enquires relating to editorial matters ('letters to the editor', submissions of articles and educational papers, requests for authors' notes etc.) and distribution of the *Journal* should be sent to the Managing Editor, Deputy Managing Editor, or Administration Manager, as appropriate, at the following address: *BTE Journal/IBTE Administration Office*, 3rd Floor, 84-89 Wood Street, London EC2V 7HL. (Telephone: 01-356 8050; Fax: 01-356 8051; Gold Mailbox: 73:TAI009.)



# THE INSTITUTION OF BRITISH TELECOMMUNICATIONS ENGINEERS

(Founded as the Institution of Post Office Electrical Engineers in 1906)

General Secretary: Mr. J. H. Inchley, NPW2.1.6, 4th Floor, 84-89 Wood Street, London EC2V 7HL; Telephone: 01-250 9816.  
(Membership and other enquires should be directed to the appropriate Local-Centre Secretary as listed on p. 220 of this issue of the *Journal*.)

## IBTE LOCAL-CENTRE PROGRAMMES 1988-89

### Central Midlands Centre

15 November 1988:

*Energy and Nuclear Power* by a speaker from British Nuclear Fuels Ltd. Meeting will be held at the British Telecom Sports and Social Club, Queens Road, Coventry. Joint IBTE Senior/Associate Section Sections lecture (Birmingham/ Coventry). Free buffet and wine from 18.30 hours, lecture commences at 19.30 hours.

5 December 1988:

*BBC Radio Data System* (lecturer to be advised). Meeting will be held at Aston University Management Centre, Birmingham, commencing at 18.30 hours, buffet from 18.00 hours. Joint IEE/IBTE/Royal TV Society meeting.

7 December 1988:

*Towards Top Telco* by Mr. J. C. Stockbridge, Director, Headquarters Projects, British Telecom UK Communications. Meeting commences at 14.00 hours.

### East Anglia Centre

22 November 1988:

*The CEBG and Nuclear Power* by Mr. M. Wasson, Health Physicist, Bradwell Power Station. Meeting will be held at Essex University, Colchester, commencing at 14.00 hours.

11 January 1989:

*CSS, Fundamental Principles* by Mr. K. Smith, Implementation Director, Thamesway District. Meeting will be held at Essex University, Colchester, commencing at 14.00 hours.

15 February 1989:

*Britain and the Sea, A Maritime Review* by The Royal Navy Presentation Team, led by Lieutenant Commander T. J. Henry, R.N.. Meeting will be held in the Mumford Theatre, Cambridge College of Arts and Technology, East Road, Cambridge, commencing at 14.00 hours.

15 March 1989:

*Cellular Radio* by Mr. D. Wordley, Director Market and Product Development, Cellnet. Meeting will be held in the Music Room, Assembly House, Theatre Street, Norwich, commencing at 14.00 hours.

### East Midlands Centre

All meetings will commence at 14.00 hours.

16 November 1988:

*Active Control Technology (Fly by Wire)* by Mr. T. D. Smith, British Aerospace. Meeting will be held at Nottingham University.

7 December 1988:

*The Service Centre* by Mr. R. Alcock, British Telecom UK Communications, and K. Daniel, East Midlands District. Meeting will be held at Leicester University.

11 January 1989:

*How to Spend £7M per Day* by Mr. C. Foxell, Managing Director, British Telecom Engineering and Procurement. Meeting will be held at Northampton Polytechnic.

8 February 1989:

*Tomorrow's External Plant* by Mr. D. Clow, Local Broadband Networks and External Plant Division, British Telecom UK Communications. Meeting will be held at Nottingham University.

8 March 1989:

Visit to Derby Computer Centre. Host: M. Bowler, East Midlands District.

### Liverpool Centre

16 November 1988:

*Network Developments* by Mr. A. G. Bealby, General Manager Network Operations Support, British Telecom UK Communications. Meeting will be held at UMIST, Manchester. Joint meeting with Manchester Centre.

18 January 1989:

*The Territory—Its View of a District* by Mr. E. Jackson, Territorial Director, Scotland, North England and Northern Ireland. Meeting will be held at the Liverpool Museum, William Brown, Street, Liverpool, commencing at 14.00 hours.

15 February 1989:

*Interconnection Strategy—Mercury etc.* by Mr. D. Peacock, Head of Interconnection Strategy, Corporate Interconnect Policies, British Telecom. Meeting will be held at the Liverpool Museum, William Brown, Street, Liverpool, commencing at 14.00 hours.

15 March 1989:

*The Network* by Mr. K. E. Ward, Chief Engineer, Network Planning and Works, British Telecom UK Communications. Meeting will be held at the Liverpool Museum, William Brown, Street, Liverpool, commencing at 14.00 hours.

19 April 1989:

*Network Operations and Management—A Customer's Perspective* by Mr. R. M. Falconer, Network Services Manager, Imperial Chemical Industries. Location to be advised; contact Brian Stewart 051-229 4444.

### **Martlesham Heath Centre**

Meetings will be held in the John Bray Lecture Theatre, British Telecom Research Laboratories, Martlesham Heath, commencing at 16.00 hours.

29 November 1988:

*Things that go Bump in the Night* by Mr. W. Hancock, Emergency Plans Officer, Suffolk County Council.

13 December 1988:

*3D TV: Fact or Fiction?* by Dr. D. I. Crawford, Visual Telecommunications Division, British Telecom Engineering and Procurement.

25 January 1989:

*The Rise and Fall of Digital Transmission (and Switching?)* by Dr. P. Cochrane, Main Optical Networks Division, British Telecom Engineering and Procurement.

7 February 1989:

*Yellow Pages—More Paper than Glue* by Mr. P. Fry, Business Development Manager, Yellow Pages.

22 February 1989:

Short papers evening: 'That Problem and its Solution'. Contributions from staff at British Telecom Research Laboratories.

7 March 1989:

*The Role and Objectives of the Overseas Division* by Mr. J. Poston, Marketing Director, British Telecom Overseas Division.

22 March 1989:

*Applied Research at Bellcore—The First Five Years* by Mr. A. Chynoweth, Vice President, Applied Research, Bellcore.

### **North and West Midlands Centre**

5 December 1988:

*Radio Navigation Systems for Ships and Aircraft*, Mr. J. D. Last, School of Engineering Science, University College of North Wales, Bangor. Meeting will be held at British Telecom Technical College, Stone, Staffordshire, commencing at 18.00 hours. Joint IEE, IERE, IBTE meeting.

16 January 1989:

*Use of Satellite Broadcasting in Training and Education* by Mr. R. Lamb, Principal, British Telecom Technical College. Meeting will be held at British Telecom Technical College, Stone, Staffordshire, commencing at 13.45 hours.

23 January 1989:

*Use of Satellite Broadcasting in Training and Education* by Mr. R. Lamb, Principal, British Telecom Technical College. Meeting will be held in Wolverhampton, commencing at 13.45 hours.

13 February 1989:

*Telecom Gold* by Mr. S. Wood, Head of Messaging, Dialcom UK Ltd. Meeting will be held at British Telecom Technical College, Stone, Staffordshire, commencing at 13.45 hours.

6 March 1989:

Title of lecture to be announced. Presenter: Professor Bryan Carsberg, Director General, OFTEL. Meeting will be held at British Telecom Technical College, Stone, Staffordshire.

### **North East Centre**

All meetings will commence at 14.00 hours.

6 December 1988:

*A Glimpse of the Future* by Dr. T. R. Rowbotham, British Telecom Research Laboratories. Meeting will be held in Newcastle.

10 January 1989:

*Managing Tomorrow's Network*. Speaker to be announced. Meeting will be held in Middlesbrough.

7 February 1989:

*Gateway Remote Alarm System* by Mr. E. Heatlie, Deputy Estates Manager, East of Scotland District. Meeting will be held in Newcastle.

March 1989 meeting to be announced.

### **North Wales and Marches Centre**

All meetings will commence at 14.00 hours.

13 December 1988:

*The Future of the Socket on the Wall—I.420 Interface and Beyond* by Mr. M. F. J. DeLapeyre, Research and Technology Department, British Telecom Engineering and Procurement. Meeting will be held at the Beauchamp Hotel, Shrewsbury.

17 January 1989:

*Itemised Billing* by Mr. C. J. Harley, Engineering Projects Manager, North Wales and Marches District. Meeting will be held at the Queen Hotel, Chester.

7 February 1989:

*District Data Networks* by Mr. W. J. Jones, Network Manager, North Wales and Marches District DISU. Meeting will be held at Whittington House, Oswestry.

7 March 1989:

*Total Network Management* by Mr. J. K. Davidson, Network Operations Centre Manager, British Telecom UK Communications. Meeting will be held at the Beauchamp Hotel, Shrewsbury.

### **Northern Ireland Centre**

Meetings will be held at the YMCA Minor Hall, Wellington Place, Belfast, commencing at 15.30 hours.

7 December 1988:

*Satellite TV: Practical Approach to Installation* by Mr. A. Williams, and Mr. M. Trott, Network Works Planning and Implementation Division, British Telecom UK Communications.

11 January 1989:

*Gateway Remote Alarm Handling System* by Mr. E. Neatlie, Exchange Power and Planning Manager, East of Scotland District.

8 February 1989:

*CSS in BTNI*. Nominated speaker from CSS implementation and user staff.

8 March 1989:

*Future Developments in the Public Network* by Dr. D. M. Leakey, Chief Scientist, British Telecom.

5 April 1989:

*The Effect of Value Added Service on BT and its Customers* by Mr. C. Jones, Director, Dialcom Group Europe.

### Sevenside Centre

22 November 1988:

*Future Developments in System X and the Local Network* by Mr. J. Dawson, Local Network Project Director, GEC Plessey Telecommunications Ltd. Meeting will be held at the Watershed Media Centre, Bristol, commencing at 14.15 hours. Joint meeting with Associate Section.

8 February 1989:

*Decision Support Systems* by Mr. P. H. Shanks, District Engineering Manager, Sevenside District. Meeting will be held at Nova House, Bristol, commencing at 14.15 hours.

29 March 1989:

*Future Trends in Public Telecommunications Networks* by Dr. D. M. Leakey, Chief Scientist, British Telecom. Meeting will be held at the Watershed Media Centre, Bristol, commencing at 14.15 hours. Joint meeting with Associate Section.

### South Downs Centre

Meetings will be held in the Lecture Theatre, Central Library, Richmond Road, Worthing, commencing at 12 noon.

15 November 1988:

*So What's New in the Local Network* by Mr. L. Bickers, British Telecom Research Laboratories.

13 December 1988:

*British Rail Signalling* by Mr. P. Pilbrow, Network South East.

10 January 1989:

*Total Network Management* by Mr. J. K. D. Davidson, Manager of Network Operations Centre, British Telecom UK Communications.

14 February 1989:

Three local lectures:

- (a) *Energy Conservation* by Mr. C. Pengelly.
- (b) *DISU* by Mr. R. Haddock.
- (c) *New BT Products* by Mrs. B. Payne.

14 March 1989:

*Telecommunications Networks—Some Possible Developments over the Next Decade* by Dr. D. M. Leakey, Chief Scientist, British Telecom.

### South Midlands Centre

16 November 1988:

*Network Restructuring* by Mr. Keith Sandhum, Head of Network Structure and Planning, British Telecom UK Communications. Meeting will be held at Wilton Hall, Bletchley, commencing at 14.15 hours.

18 January 1989:

*Optical Technology* by Mr. M. Howard. Meeting will be held at Wilton Hall, Bletchley, commencing at 14.15 hours.

15 February 1989:

*Power and Building Engineering Services* by Mr. P. A. Allen, Head of Power and Building Services Division, British Telecom UK Communications. Meeting will be held at Wilton Hall, Bletchley, commencing at 14.15 hours.

15 March 1989:

*Whatever Happened to the Candelstick* by Dr. I. S. Groves, Divisional Manager, Telephony and Data Products Division, British Telecom Engineering and Procurement. Meeting will be held at Wilton Hall, Bletchley, commencing at 14.15 hours.

### IBTE CENTRAL LIBRARY

The books listed below have been added to the IBTE Library. Copies of the 1982 edition of the library catalogue are available from the Librarian, IBTE, Room GJ, 2-12 Gresham Street, London EC2V 7AG. An abbreviated catalogue was included in the October 1987 issue of the *Journal*. Library requisition forms are available from the Librarian, from Local-Centre and Associate Section Centre Secretaries and representatives. The forms should be sent to the Librarian. A self-addressed label must be enclosed.

Alternatively, the IBTE Library is open on Wednesday mornings between 11.00 and 13.30. Members are advised to telephone the Librarian (01-356 8050) to confirm their visit. Members wishing to reserve books or check availability should contact the Library during opening times on 01-356 7919.

The Library is open to Full, Associate Section and retired Members of the IBTE.

5457 *The Mapping of Geological Structures*. Ken McClay.

The handbook is written to show how one actually describes, measures and records rock structures, such as folds and faults, with the emphasis on accuracy, detail and ongoing interpretation throughout. The book gives students and enthusiasts the practical information and guidance which allows their fieldwork to become more rewarding. Detailed mapping and analysis of the structural features of rocks enable the three-dimensional geometry of their structures to be reconstructed. The resulting evidence of the stresses and movement patterns which rocks have undergone indicates the processes by which they were formed, and allows evaluation of past deformations of the earth's crust.

5458 *Time Travel and Other Mathematical Bewilderments*. Martin Gardner.

From coincidences that seem to violate the laws of time and space, to the perplexities of the rubber rope, to the centuries-old delights of tangram play, the puzzles, problems and paradoxes presented in this book reveal just how enlightening and entertaining mathematical recreations can be. This is



the twelfth and latest collection of brain teasers drawn from the authors 'Mathematical Games' column, one of the most popular features of *Scientific American*. Addicts and math-shy novices will enjoy these games and problems which offer hours of stimulation, frustration and satisfaction.

5459 *Introduction to Fortran 77 and the Personal Computer*. Hammond, Rogers and Crittenden.

Very little has appeared in print directly relating FORTRAN and the personal computer. The availability of workable FORTRAN compiler programs designed to be used on the personal computer has created a need for this textbook, which introduces a beginner to the FORTRAN language implementation on the personal computer. The book outlines the simplified logic of computer programming and details the rudiments of programming in the 1977 version of the FORTRAN language.

5460 *Digital, Analog and Data Communications*. William Sinnema, and Tom McGoven.

Digital communications systems are being rapidly developed to provide reliable communication for analogue signals and

data. Analogue signals such as voice must first be translated into a digital format whereas data can be directly carried. Data transmission is probably the fastest growing aspect of communications, mainly because of the advent of the computer and microprocessor. It is therefore important for technologists and engineers to become aware of the transmission techniques involved. This book attempts to acquaint the reader with the telephone network and with the principles and applications of digital communications.

5461 *The Monthly Sky Guide*. Ian Ridpath, and Wil Tirion.

This is the ideal guide to help beginners find their way around the sky. It contains maps of the sky for each month of the year, realistically depicting the stars visible to the naked eye. With these charts, the reader can identify the stars and constellations visible on any night of the year. In addition, specific constellations of interest are treated in detail each month, with a map and descriptions of selected objects, stars, clusters, nebulae and galaxies for viewing with binoculars or a small telescope. There are notes on meteor showers and the positions of the planets are given for a five-year period.

## MEMBERSHIP OF THE BOARD OF EDITORS

The Board of Editors of *British Telecommunications Engineering* comprises the Chairman and two Members of the IBTE Council together with four co-opted members and the officers of the *Journal*.

### Chairman:

Mr. J. Tippler  
01-356 4941

Director Network  
BT Centre B8095  
81 Newgate Street  
London EC1A 7AJ

The Director Network has the functional responsibility for the planning, programming, and economic operation of the inland network.

### IBTE Council Nominees:

Mr. R. N. Williams  
(0222) 391586

Materials Operations Manager  
MG1  
25 Pendwyallt Road  
Coryton  
Cardiff CF4 7YR

Materials Operations Manager for South Wales District exchange network support unit.

Mr. W. Carlyle  
(0223) 344344

Head of Operations  
Cambridge CSA  
Telephone House  
1 Regent Street  
Cambridge  
CB2 1BA

Customer apparatus maintenance and installation, external network provision and maintenance, together with service area sales office and customer complaints.

### Co-opted Members:

Dr. G. White  
(0473) 642570

Division Manager  
RT56  
British Telecom  
Research Laboratories  
Martlesham Heath  
Ipswich IP5 7RE

Division Manager Design Technology Division at British Telecom Research Laboratories.

Mr. P. B. Frame  
01-728 9700

General Manager  
NDE  
203 High Holborn  
London WC1V 7BU

Departmental Efficiency of Network Headquarters.

Mr. I. G. Morgan  
01-728 9742

Manager  
MNOS1  
203 High Holborn  
London WC1V 7BU

Operational support to System X AXE10 and UXD5 switching systems including exchange transfers, BIS and in-service support, maintenance procedures and operational efficiency.

Dr. M. W. Evans  
(0394) 693706

Senior Products Development  
Manager  
IPD  
Room 321 Anzani House  
Trinity Avenue  
Felixstowe  
Suffolk IP11 8XB

Design and development of telephone products for UK Communications, and the introduction of digital cordless technology products (CT2) into UK, Europe and North America. Also, the development of messaging terminals (M2120) and analogue cordless products (CT1).

## LOCAL-CENTRE SECRETARIES

The following is a list of Local-Centre Secretaries, to whom enquiries about the Institution should be addressed.

<i>Centre</i>	<i>Local Secretary</i>	<i>Address and Telephone Number</i>
Aberdeen	Mr. A. T. Mutch	British Telecom, D2.1.6, New Telecom House, 73-77 College Street, Aberdeen AB9 1AR. Tel: (0224) 753343.
Central Midlands	Mr. G. R. Chattaway	British Telecom, BES5.5, Leofric TE, Little Park Street, Coventry CV1 2JY. Tel: (0203) 228396.
East Anglia	Mr. T. W. Birdseye	East Anglia District PD2.1.5, St. Peters House, 22 St. Peters Street, Colchester CO1 1ET. Tel: (0206) 894041.
East Midlands	Mr. D. H. Bostrom	ES22, Albion House, South Albion Street, Leicester LE1 6JL. Tel: (0533) 534052.
Liverpool	Mr. B. Stewart	British Telecom Liverpool District, CS63, Lancaster House, Old Hall Street, Liverpool L3 9PY. Tel: 051-229 4444.
London	Mr. C. J. Webb	British Telecom, LSO/PA1.6.4, Room 119B, Camelford House, 87 Albert Embankment, London SE1 7TS. Tel: 01-587 8853.
Manchester	Mr. J. M. Asquith	British Telecom, NE20, Telecom House, 91 London Road, Manchester M60 1HQ. Tel: 061-600 5171.
Martlesham Heath	Mr. K. R. Rose	British Telecom Research Laboratories, RT5211, Martlesham Heath, Ipswich IP5 7RE. Tel: (0473) 642676.
North and West Midland	Mr. R. J. Piper	c/o Mr. M. N. B. Thompson, BT Technical College, Stone, Staffordshire ST15 0NL. Tel: (0785) 813483.
North Downs and Weald	Mr. N. Smith	British Telecom, NP4, Telephone House, Rheims Way, Canterbury, Kent CT1 3BA. Tel: (0227) 474594.
North East	Mr. P. L. Barrett	British Telecom North East, EP38, Swan House, 157 Pilgrim Street, Newcastle-upon-Tyne NE1 1BA. Tel: 091-261 3178.
North Wales and the Marches	Mr. P. C. Clay	E343, Communication House, Harlescott Lane, Shrewsbury SY1 3AQ. Tel: (0743) 246713.
Northern Ireland	Mr. B. Hume	EI4, RAC House, 79 Chichester Street, Belfast BT1 4JE. Tel: (0232) 227152.
Preston	Mr. A. J. Oxley	BK/CP2, Telephone House, 10 Duke Street, Blackburn BB2 1VA. Tel: (0254) 666390.
Scotland East	Mr. B. Curry	British Telecom East of Scotland District, NJ3, Telephone House, 357 Gorgie Road, Edinburgh EH11 2RP. Tel: 031-345 4218.
Severnside	Mr. P. C. James	British Telecom, ED2, St. Clements House, Marsh Street, Bristol BS1 4AY. Tel: (0272) 266773.
Solent	Mr. D. Henshall	BE33, Solent District Office, 70-75 High Street, Southampton SO9 1BB. Tel: (0703) 823421.
South Downs	Mr. C. J. Mayhew	British Telecom South Downs District Office, ED8, Grenville House, 52 Churchill Square, Brighton, BN1 2ER. Tel: (0273) 225802.
South Midlands	Mr. D. R. Norman	British Telecom, ES1.6.2, Telecom House, 25-27 St. Johns Street, Bedford MK42 0BA. Tel: (0234) 274092.
South Wales	Mr. P. F. Coleman	LN9, Empire ATE, Park Street, Cardiff CF1 1NT. Tel: (0222) 395809.
Thamesway	Mr. R. D. Hooker	Thamesway District Head Office, DE4.4, Telecom House, 49 Friar Street, Reading, Berkshire RG1 1BA. Tel: (0734) 501754.
West of Scotland	Mr. L. M. Shand	TNO/S1.4.4, Dial House, Bishop Street, Glasgow G3 8UE. Tel: 041-221 1585.
Westward	Mr. R. Rand	British Telecom, NP2, Exbridge House, Commercial Road, Exeter EX2 4BB. Tel: (0392) 212681.
Yorkshire and Lincolnshire	Mr. R. S. Kirby	UKC/SNE & NI/QO1.3, Netel House, 6 Grace Street, Leeds LS1 1EA. Tel: (0532) 466366.

## ASSOCIATE SECTION REGIONAL CONTACT POINTS

The following is a list of Associate Section regional contact points to whom enquiries about the Associate Section should be addressed.

<i>Region</i>	<i>Local Secretary</i>	<i>Telephone Number</i>
East	Mr. T. Turner	(0582) 32936 (evenings only)
London	Mr. P. Lendon	01-829 3180
Midlands	Mr. M. P. Melbourne	(0623) 650276
North East	Mr. K. Whalley	(0642) 310937
North West	Mr. R. Craig	(0772) 267236
Northern Ireland	Mr. G. Ming	(0504) 44444
Scotland	Mr. C. Ritchie	(0224) 573451
South East	Mr. R. P. Coveney	(0634) 45500
South West	Mr. J. R. Dymott	(0202) 206497
Wales North	Mr. R. Fairley	(0352) 713190
Wales South	Mr. H. P. Duggan	(0222) 379732

# Book Reviews

## *Business Earth Stations for Telecommunications*

Walter L. Morgan, and Denis Rouffet.

John Wiley and Sons Ltd., xxi + 234 pp. 105 ills. £31.95.  
ISBN 0-471-63556-1.

This book is aimed at providing a practical guide to the application of satellite system microterminals to the business communications network. It is specifically targeted towards the satellite system operators and equipment manufacturers whose requirement is for systems with antenna diameters not exceeding 1.8 m. A secondary audience will be found in government and local-authority officials who wish to understand in more detail the subject which they are increasingly required to regulate.

The text commences at a level that is easily understood by the absolute novice, by describing basic satellite systems and microterminal equipment. It then builds gradually to include descriptions of different modulation schemes and their relevant applications.

Suitable applications are covered in some detail and this section, coupled to a chapter on microterminal network operating procedures, provides some useful general information that is relevant to any such network. The operating techniques are addressed by breaking down an example network into small elements and then illustrating the function of each element in the control and operation of the overall network.

Both the potential business user and the network provider should find the information regarding system economics and possible applications of particular interest. It should be stressed that the book is written in the US and the majority of the information contained in these sections and that concerning regulatory aspects, refer to the situation, market and economics of scale that exist in the US.

From the point of view of the UK reader, the latter aspect is the most serious shortcoming of the book, in that there is a wealth of specific information that is not particularly relevant to the European situation.

Apart from this, the book provides a concise, easily read, definitive work on the rapidly evolving satellite microterminal for business use and will be equally useful to both the network provider and the private business telecommunications manager.

J. R. E. CUBBIN

## *Transmission Principles for Technicians*

D. C. Green.

Longman Scientific and Technical, 197 pp. 241 ills.  
£7.95.

ISBN 0-582-99461-6

In his preface, the author states that the intended UK readership is the student of either Business and Technical Education Council (BTEC) or City and Guilds of London Institute units in Transmission Principles at both levels II and III. He goes on to explain that the early chapters present the basic concepts of signals, modulation, noise and transmission lines and later chapters employ these concepts to introduce practical transmission systems.

The first four chapters cover the following subjects: signals, frequency, wavelength, velocity, modulation, carrier frequencies and bandwidths. In general, these subjects are

explained well, although some topics suffer a little from over simplification. There are two diagrams in the chapter on modulation containing errors, neither of which is too serious, but anybody not already familiar with pulse position modulation (PPM) would be unable to grasp the principles of PPM from this book. Some important equations are unfortunately 'hidden' within the written text. A separate page or two at the end of each chapter listing equations would have greatly assisted the student revising for examinations. It was, however, very pleasing to see a short section on CCITT and CCIR in Chapter 4.

Basic transmission line theory and noise are explored in Chapters 5 and 6. Both these subjects are handled comprehensively and well; digital signals and digital modulation in Chapters 7 and 8 are similarly covered. Sadly, the book makes no mention of the di-phase modulation technique WAL2, which is currently being used extensively in British Telecom for the KiloStream service.

Attenuators, equalisers and filters are discussed in Chapter 9. These areas of transmission theory are adequately described with the possible exception of the piezo-electric crystal, which is given very superficial coverage. But, as this is a very complex subject, and bearing in mind the target readership, this is probably sufficient.

Chapter 10, which covers 2-wire and 4-wire circuits, is very disappointing and contains several errors. The diagram explaining the 4-wire amplified circuit uses outdated symbols which contradict those shown in the previous chapter. In addition, both the text and the diagram state that all amplifiers in a 4-wire circuit would have outputs of +10 dbm, which is certainly not the case in practice. No attempt is made to use the correct dB notation throughout this section.

The chapters on FDM, PCM and data circuits are excellent and the explanation of quantizing is particularly good. The final chapter on optical-fibre systems is, unfortunately, not so good. The basic optical theory is sound but the practical applications are sketchy to the point of being potentially misleading. The effect of 'transit time dispersion' could have been much better illustrated. The term 'multi-mode dispersion' was used with no reference to the earlier expression 'transit time dispersion'. The basic block diagram and text explaining an optical line system suggest that the HDB3 signal input is scrambled and encoded directly. An HDB3 decoder should be included before processing the data. The text states that the reason for scrambling is to prevent 'interference with adjacent optical fibres'. This is in conflict with the previously stated advantage of fibres which is the virtual absence of crosstalk. This section would have been substantially improved by a more thorough account of the signal processes, which of course are not exclusive to optical line systems.

At the end of the book, there are some useful questions and answers to enable readers to test their understanding of each subject, followed by a very full index.

One surprising omission from this book is a chapter on the decibel (dB) and dB notation. The dB is a fundamental transmission unit and is also part of the BTEC Transmission Principles syllabus and should have been included.

Despite the criticisms made in this review the overall opinion of the book is a good one. The text and diagrams are, in general, well presented and make fairly easy reading of what can be a difficult subject. It will prove of great benefit to students of the aforementioned courses and, retailing at only £7.95, represents very good value.

J. A. EVANS



# British Telecommunications Engineering

If you wish to subscribe to *British Telecommunications Engineering*, please complete the relevant section of the order form below and send it to the address given. British Telecom (BT) and British Post Office (BPO) staff should complete the upper section and other subscribers the lower section. A photocopy of this form is acceptable.

## SUBSCRIPTION ORDER (BT and BPO STAFF)

To: *British Telecommunications Engineering Journal*,  
3rd Floor, 84-89 Wood Street,  
London EC2V 7HL.

**British Telecommunications Engineering:  
Authority for Deduction from Pay**

Please arrange for me to receive *British Telecommunications Engineering*. I have completed the form opposite authorising deductions from pay to cover the special annual subscription of £3.60

I, .....  
(name in full, surname first in block capitals), authorise the deduction from my salary or wages, until further notice, of the sum of 30p per month/7p per week for payment to the Managing Editor, *British Telecommunications Engineering*, on my behalf.

Date ..... Signature .....

Date ..... Signature .....

Name and initials .....  
(in block capitals)

IBTE Associate Section membership (Note 3) YES/NO

Official address .....

Home address (Note 1) .....

Rank ..... Pay No. (Note 2) .....

District/Area/Dept. ....

Postcode .....

Pay group reference (Note 2) .....

Pay group reference (Note 2) .....

- Notes: 1 The *Journal* will be sent to your home address.  
2 Your pay number and pay group reference are printed on your salary slip.  
3 Indicate whether you are a member of the Associate Section of the Institution of British Telecommunications Engineers (IBTE). Full Members of the IBTE receive the *Journal* as part of their IBTE subscription.

## YEARLY SUBSCRIPTION ORDER (NON-BT/BPO STAFF)

To: *British Telecommunication Engineering Journal*,  
3rd Floor, 84-89 Wood Street,  
London EC2V 7HL.

Please supply 4 quarterly issues of *British Telecommunications Engineering*. I enclose a cheque/postal order for the sum of £8 (UK) or £10 (overseas) to cover the yearly subscription. (Overseas customers should pay by sterling drafts drawn on London. Payment by cheques drawn in US dollars will be accepted at the higher price of \$22.00 to allow for bank charges.)

(Cheques and postal orders, payable to 'BTE Journal', should be crossed '& Co.' and enclosed with the order. Cash should not be sent through the post.)

Name .....

Address .....

.....  
.....  
.....  
.....

Please state with which issue you wish your subscription to commence (April, July, October or January) .....



# THE INSTITUTION OF BRITISH TELECOMMUNICATIONS ENGINEERS

(Founded as the Institution of Post Office Electrical Engineers in 1906)

---

## MEMBERSHIP

of

## THE FEDERATION OF TELECOMMUNICATIONS ENGINEERS OF THE EUROPEAN COMMUNITY (FITCE)



FITCE is an organisation with similar objects to IBTE and draws its members from the public telecommunications administrations of Belgium, Denmark, Eire, France, Greece, Italy, Luxembourg, the Netherlands, Spain, Portugal, the UK and West Germany. FITCE publishes a quarterly Journal from its Brussels headquarters, sponsors multi-national study groups (Commissions) to enquire into and report on problems of general interest, and each year organises a General Assembly/Congress in one of the member countries.

Full membership of FITCE in the UK is available only through IBTE. Members and Affiliated Members of IBTE who hold a University science degree or who are Chartered Engineers may join through the FITCE Group of IBTE. The annual subscription for 1988/9 is £5.00; this covers local administration expenses as well as the *per capita* contribution to FITCE funds, and thus ensures that no charge proper to FITCE affairs will fall upon the general membership of IBTE. Membership forms are available from your Local-Centre Secretary or direct from the Assistant Secretary (FITCE), Mr T Ray, Assistant Secretary, IBTE/FITCE Group, UKC/NPW4.1.6, 3rd Floor, D Wing, The Angel Centre, 403 St John Street, London, EC1V 4PL; Tel: 01-239 0810.

**THIS IS YOUR OPPORTUNITY TO PLAY AN ACTIVE PART IN CO-OPERATION  
WITH TELECOMMUNICATIONS ENGINEERS FROM OTHER EUROPEAN COUNTRIES**

---



T H E · I B T E  
LIBRARY

2-12 Gresham Street, London, EC2V 7AG

**Personal visits**

The IBTE Library will be open on Wednesday between 11.00 and 13.30  
Please advise the librarian (01-356 8050) of intended visits

**Postal applications**

These should be made to the Librarian. Forms and catalogues are available from  
the Librarian, Local-Centre and Associate Section Centre Secretaries

**Reservations**

Telephone the Library during opening hours (01-356 7919) to reserve books  
or check availability

The Library Service is available to Full, Associated and retired members of IBTE





---

"ADVANCED TECHNOLOGY FROM AT&T NETWORK SYSTEMS UK Ltd. IS THE MOST COMPREHENSIVE AVAILABLE TODAY, AND HAS MADE ADVANCED LINKLINE POSSIBLE" (BRITISH TELECOM).

---

The advanced LinkLine freephone service is a highly effective marketing tool, creating new business opportunities both for British users and British Telecom. It provides freephone calls to subscribers, so increasing orders, generating sales leads and allowing the introduction of many new services.

Advanced LinkLine, employing the advanced 5ESS-PRX digital exchanges from AT&T NETWORK SYSTEMS UK Ltd., was evaluated as the most comprehensive, versatile system currently available.

It incorporates a number of novel features which may be combined into different configurations, tailored to the needs of individual user, however large or small.

It means that every connection is successful, regardless of time, traffic or staff, making us one of the very few companies with the capacity, creativity and resources to handle such projects even on a turnkey basis both now and well into the 21st Century! If you want to know more about our work and how it can affect your future, ask us for our brochure.

AT&T NETWORK SYSTEMS UK Ltd., Swindon Road, Malmesbury, Wiltshire, England SN16 9NA. Telephone: (0666) 822861  
Fax: (0666) 824515 Telex: 44208 APTMAL G

---

**AT&T NETWORK SYSTEMS UK Ltd.**  
*YOUR CONNECTION WITH THE FUTURE.*

---



# Contents

VOL 7 PART 3 OCTOBER 1988

<b>Editorial</b>	<b>161</b>
<b>The Mezza System</b> R. E. Walters, G. D. Roxburgh, and D. Newey	<b>162</b>
<b>Rural Telecommunications in a Third World Country</b> E. J. Welsh, and D. deCruz	<b>172</b>
<b>Using CEDRIC to Commission System X Concentrators</b> R. A. Startin, R. F. Booth, B. B. Trawford, J. C. Denny, and J. Barnes	<b>179</b>
<b>The Physical Design of Antenna Support Structures — State of the Art</b> D. G. Clow	<b>187</b>
<b>Towards a European Telecommunity</b> A. Boesveld	<b>194</b>
<b>Common European Objectives</b> P. C. Jones	<b>200</b>
<b>Moling and Other Trenchless Techniques Used in British Telecom — An Overview</b> A. W. Renshaw	<b>205</b>