

# British Telecommunications Engineering

---

VOL 2 PART 4 JANUARY 1984



The Journal of  
The Institution of British Telecommunications Engineers

# BRITISH TELECOMMUNICATIONS ENGINEERING

VOL 2 PART 4 JANUARY 1984

## Contents

Editorial	231
The Fully-Mechanised Traffic-Recording System T. R. C. Beard	232
High-Level Hardware Description Languages: A New Computer-Aided Design Tool J. F. Buckley	239
Circuit Provision in the System X Era P. R. Harris	244
Equipment Cooling for Modernisation W. G. Brown	246
Parcel Traffic Recording—TRIPOS H. R. Henly, and R. I. Harcourt	251
SEQUIN—A Computerised Information System for Enquiry Operators D. R. Ewers, F. Bennett, and G. Payne	254
New Transformer/Rectifier Units for the Post Office Railway R. E. Finden, P. Piqué, and K. Kettridge	256
The Tenth International Teletraffic Congress, Montreal, 1983 N. W. MacFadyen	259
Processor-Controlled Systems for the Testing of Customers' Lines D. V. Thorpe	261
The Sixth International Conference on Computer Communication: A Review Part 2—The Specialist Sessions M. B. Williams	267
Royal Videoconference for STD Anniversary	275
TELECOM 83: A Retrospective Look D. B. Willson	276
Martlesham Medal Winners for 1983	278
Forthcoming Conferences	279
Institution of British Telecommunications Engineers	280
Notes and Comments	280
Profiles of Senior Staff	281
British Telecom Press Notices	282, 283, 284
Book Reviews	238, 260

Published in April, July, October and January by *British Telecommunications Engineering Journal*,  
2-12 Gresham Street, London EC2V 7AG.

(Formerly *The Post Office Electrical Engineers' Journal* Vols. 1-74: April 1908-January 1982)

Price: 90p (£1.40 including postage and packaging). Orders by post only.

Annual subscription (including postage and packaging): home and overseas £5.60.  
(Canada and the USA \$12.00).

Price to British Telecom and British Post Office staff: 48p.

© 1984: The Institution of British Telecommunications Engineers.

ISSN 0262-401X

# NOW WORLD PTT'S AND PHONE COMPANIES WILL FIND FAULTS BEFORE THEIR CUSTOMERS DO

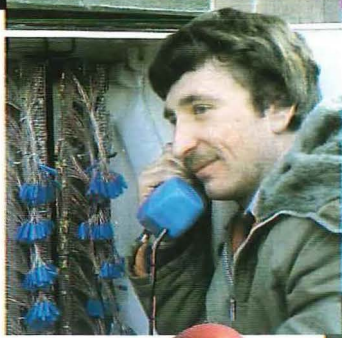

## The latest automatic testing technology from Teradyne: the Series III 4TEL System—

automatically tests every line every night and provides powerful diagnostic testing for fault finding every day. The Series III 4TEL System includes:

- Advanced system refinements based on many years of user experience.
- The latest technology in microprocessors and communications.
- New testing features designed for the needs of European PTT's.
- Testing from the field with computer generated voice response.
- The facility to network to a separate administrative data base system (ARSCC).



4TEL immediately permits major improvements in quality of service through more efficient responsive and preventive maintenance to meet quality of service objectives.

4TEL from Teradyne, one of the world's leading manufacturers of computer controlled test systems, have been field proven in rural and urban environments and are testing millions of lines now.



TEST#555 2240 TEST  
 FAULT-CABLE  
 18KΩ CONTACT  
 PROBABLE WET LINE  
 CABLE LENGTH 2.4KM  
 BELLISI-BRIDGED



Teradyne Ltd.  
 Clive House, Queens Road,  
 Weybridge, Surrey, KT13 9XB, England.  
 Telephone: Weybridge (0932) 51431.  
 +44 932 51431.

## Satellite communications- the new link.

Whatever the need, Plessey satellite ground stations provide the new link for even better national and international communications.

Proven expertise in switching and transmission systems means that Plessey has the capability to link the ground received satellite signal into public, private and local community networks.

Plessey remote stations supply high quality, reliable telephony, data, telex, television and radio links for businesses and the public.

Plessey Telecommunications Limited recently won a £1 million contract from British Telecom International for an enhanced Standard B earth station at Goonhilly Downs in Cornwall.

Plessey is responsible for the provision, installation, acceptance testing and commissioning of the earth station, which will be transmitting live in 1983.

The station will interwork with Intelsat IV, IVA, V, VA, and subsequent satellites to transmit and receive vision and sound on two colour TV channels at either 625 or 525 lines, and is capable of being extended to handle a further two channels.

*Contact Transmission Division for further information.*

## Plessey-the vital link in the London Network.

Soon, London's business community will be getting the full benefit of British Telecom's Kilastream and Megastream X-stream services — at the speed of light.

It's the result of increasing demand from British Telecom's business users for high-speed data transmission facilities. The new services will be carried by a high bit-rate, fibre optic transmission network called the London Network.

As a world leader in fibre optics, and major UK supplier of optical transmission systems, Plessey was chosen by British Telecom to supply optical transmission equipment.

The contract, worth £0.5 million, includes 8 and 34 Mbit/s line terminal equipment, intermediate station equipment and higher order muldex from the Plessey product portfolio.

With a completion date set for May 1984, Plessey is aiming to commence deliveries in November 1983, to meet British Telecom's requirements.

*Contact Transmission Division for further information.*

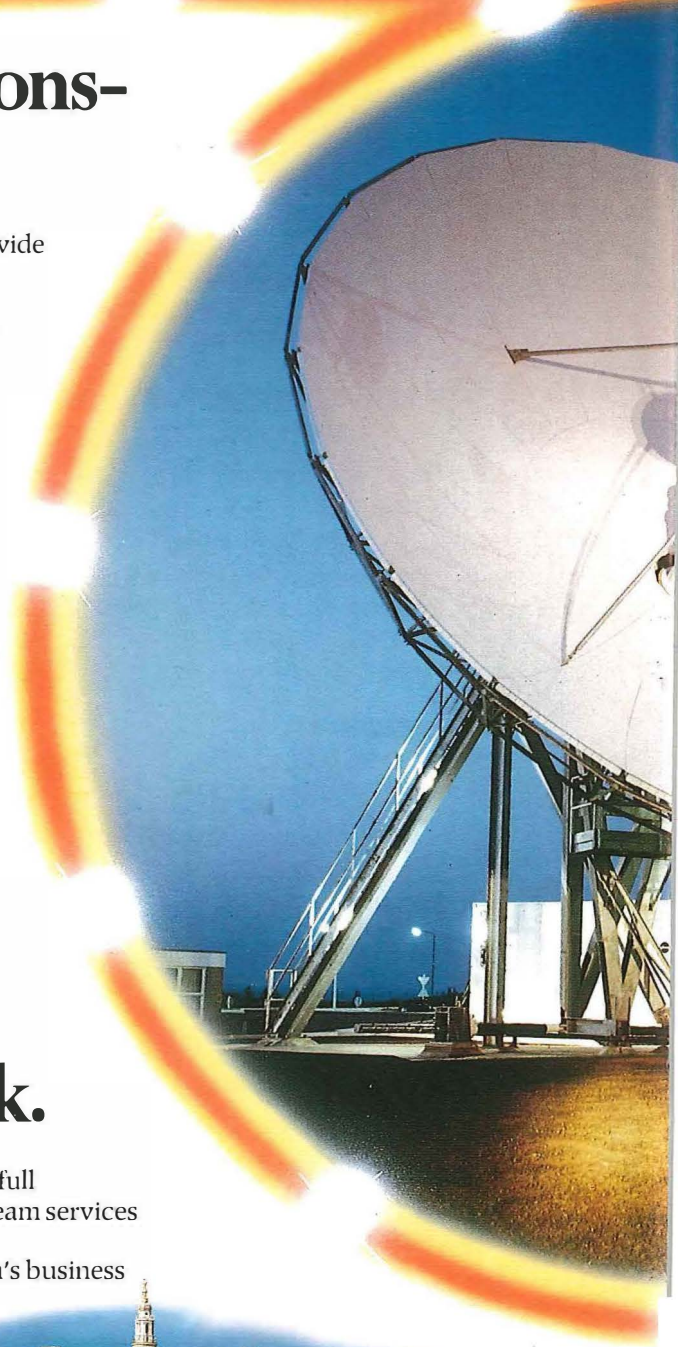
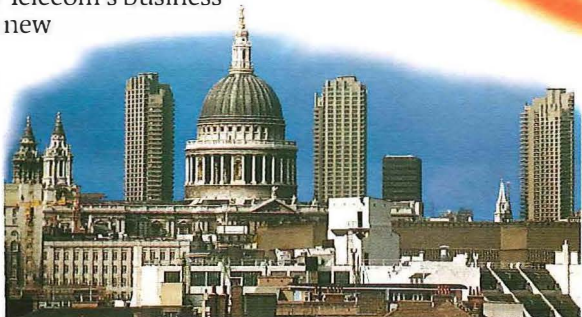

IONS.

## The London-Birmingham optical fibre link enters Phase 2 with Plessey.

In July last year Plessey formally handed over to British Telecom what was then the world's longest optical fibre route.

Reaching from London to Birmingham, the link provides two 34 Mbit/s systems

each with a capacity of 480 telephony channels or sixteen 2 Mbit/s digital streams for data transmission.

Plessey is now installing and commissioning two further 140 Mbit/s systems, each with a capability of providing 1920 telephony channels or the equivalent in data, marking Phase 2 in the London-Birmingham programme.

As a world leader in optical fibre systems Plessey continues to make fresh advances in optoelectronic technology, which is one reason why it was chosen to participate on the London-Birmingham link. For optical systems from 2 to 565 Mbit/s providing 30 to 8000 telephone channels per installed fibre, Plessey offers a total capability. *Contact Transmission Division for further information.*



## New intelligent Plessey payphones for New Zealand.

The new Plessey payphones are unique. They're tough on vandals and what's more they can function on their own—making them a highly attractive and cost effective proposition for any PTT authority.

In New Zealand, Plessey has been awarded a three-year contract (with a further right of renewal) to supply payphones to the Post Office.

In July 1982, Plessey won the £40 million contract to supply 77,000 new microprocessor controlled payphones to British Telecom.

The payphones, being installed now throughout the UK, were chosen on their high reliability, automatic status reporting, and ability to refund unused coins.



**PLESSEY**  
telecommunications

Plessey Telecommunications Limited (Transmission Division) Beeston, Nottingham, United Kingdom NG9 1LA. Tel: Nottingham (0602) 254831. Telex: 37201.

Plessey Telecommunications Limited (Telecommunications Products & Services Division), Edge Lane, Liverpool, United Kingdom L7 9NW. Tel: Liverpool (051) 228 4830. Telex: 629267.

*Contact Telecommunications Products and Services Division for further information.*





## EASY WHEN YOU KNOW HOW

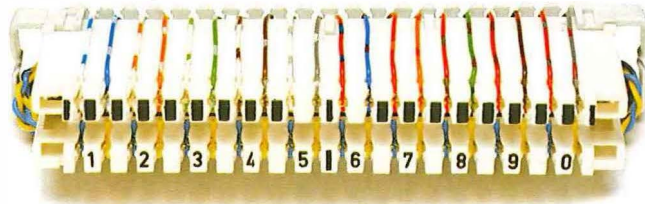

The unique KRONE LSA-PLUS quick connexion system was selected as an integral part of the British Telecom RAPIDE system from the start. Not just because it saves time, money and worry. Not simply that it does away with soldering, wire-stripping and screwing. Not even because the subtle and foolproof internal mechanism of every LSA-PLUS strip ensures a tighter, surer electrical contact and vibration resistant connexion.

**BUT BECAUSE THERE'S A**

**WHOLE PRODUCT SYSTEM  
BEHIND IT AND BECAUSE THAT  
ENTIRE SYSTEM IS MODULAR.**

With KRONE LSA-PLUS you get not only a unique connexion system but a whole modular range of strips, which fit modular boxes and cabinets; which themselves are designed to link with wholly modular sub and main frame units. (You can even order your strips direct from our headquarters already factory pre-wired on complete harnesses and system

boxes!) Small, medium or large installations — for flexibility as well as economy and ease of installation — KRONE LSA-PLUS.

For full details of the remarkable range of Krone telecommunication products, techniques and services — just phone — or write to the address below.

**MODELS OF MODULARITY**  
**KRONE**

KRONE (U.K.) TECHNIQUE LIMITED  
Runnings Road Kingsditch Trading Estate  
Cheltenham, Glos GL51 9NQ  
Telephone: Cheltenham (0242) 584900  
Telex: 43350

# British Telecommunications Engineering

---

## BOARD OF EDITORS

J. F. Boag, C.ENG., F.I.E.E., F.B.I.M., Chairman

P. B. Frame, C.ENG., F.I.E.E.

D. Mallows

C. E. Rowlands, B.S.C., C.ENG., M.I.E.E.

A. W. Welsh, C.ENG., M.I.E.E.

G. White, B.S.C., PH.D., SEN.MEM.I.E.E.E.

## Managing Editor

V. L. Dunhill, B.S.C., C.ENG., M.I.E.E.

## Deputy Managing Editor

P. E. Nichols, B.S.C.

## Secretary-Treasurer

B. Farr

## Advertisement Manager

A. J. Pritchard

## EDITORIAL

During 1983, designated *World Communications Year* by the United Nations, attention was focused on the need to redress the imbalance between the telecommunications capability of the developed and the undeveloped world. The Commonwealth Telecommunications Conference held in November at Leeds Castle, in Kent, warned that the neglect of telecommunications would hamper economic and social development in the Commonwealth and the Third World, and proposed a fund to finance telecommunications in the developing countries. The highlight of World Communications Year was the International Telecommunication Union sponsored TELECOM 83 exhibition in Geneva. Here, with the general theme *Telecommunications For All*, a vast array of telecommunication equipment, ranging from sophisticated integrated services digital network (ISDN) capability to basic rural communications, was displayed. As part of the UK's contribution to World Communications Year, 3 UXD5 digital exchanges and their supporting networks are being supplied to improve telecommunications in rural areas of Malawi.

In the UK, it is 25 years since Her Majesty The Queen inaugurated the subscriber trunk dialling service. Today, international direct dialling, available to 90% of the world's telephones, is regarded as the norm. These advances in services to the customer have taken place at a tremendous rate compared with the introduction of automatic working at Epsom in 1912 and the conversion of the last manual exchange in 1979. Within the next decade, however, even more radical changes will take place with the transition from an analogue to a digital trunk network and the integration of voice, data, text and visual communications in an ISDN. But to take advantage of these developments in communication technology in forging new trade routes with the developing countries, a basic telecommunications infrastructure must exist to create the social and economic development necessary to generate the demand for such services.

# The Fully-Mechanised Traffic-Recording System

T. R. C. BEARD†

UDC 621.395.31

*This article describes the fully-mechanised traffic-recording (FMTR) system, used by British Telecom for collecting and processing telephone traffic data from TXS and TXE4 telephone exchanges. The article starts by discussing the need for FMTR and goes on to describe the system that has been developed. An outline of the hardware used is also given.*

## INTRODUCTION

In the mid-1970s, the British Post Office (now British Telecom (BT)) started a review of the method it used to monitor the traffic flowing within the telephone network. This review was required for 3 main reasons.

Firstly, customers were being encouraged by advertising and by selective tariffs to distribute their use of the telephone network over the whole day. This meant that the traditional technique of monitoring a single hour within the day was no longer sufficient to identify the onset of congestion.

Secondly, although the processing of traffic data on main-frame computers had been introduced in 1974 (the partially-mechanised traffic-recording (PMTR) system<sup>1</sup>), the basic traffic data of the telephone exchange was still being recorded on electromechanical meters. The resulting manual collection of exchange data not only was expensive, slow and error prone, but severely restricted the flexibility available for monitoring special local traffic conditions such as race meetings, phone-in programmes or large PABXs. Such information is essential to ensure that an adequate grade of service is provided economically to customers at all times, and to enable the production of effective local planning strategies.

Thirdly, detailed traffic information was required not only to improve the utilisation of the existing equipment, but also to provide accurate and comprehensive data for the planning of the digital network.

The provision of a new traffic-recording system was clearly necessary to provide additional information for national statistics and flexibility to satisfy local requirements.

Several commercial systems were evaluated, but considered unsuitable because of high installation costs and because they did not offer the type of flexibility required. It was therefore decided to use the expanding microprocessor technology to develop an economic, flexible, self-contained traffic-recording system, which would enable each Telephone Area to take detailed records to suit local requirements, but which would also interface to the existing main-frame PMTR scheme. The PMTR system was still required as it collected data nationwide to provide information on the telephone network at a national level. This new system is called the *fully-mechanised traffic-recording (FMTR)* system, which is now operational in a number of Strowger (TXS) and electronic reed-relay (TXE4 RD/4A) telephone exchanges in 32 Telephone Areas.

## OBJECTIVES OF THE FMTR SYSTEM

The objectives of the FMTR system can be summarised as being:

(a) to provide traffic information relating to four 1 h periods during the day, instead of the previous single period, for both local and national use;

(b) to provide additional facilities to permit easy review and re-assignment of the periods being monitored;

(c) to provide the traffic-engineering staff in the Telephone Area with the means not only to generate and monitor the information required by the PMTR system, but also to study in detail the performance of exchanges under unique local conditions;

(d) to eliminate the costs, errors and traffic-recording restrictions created by the manual collection and transfer of exchange traffic data; and

(e) to serve the major non-System X exchange systems—TXS and TXE4—but to exclude very small TXS exchanges and those designated for early replacement by System X.

## MAJOR SYSTEM DESIGN FEATURES

The FMTR system is based on 2 pieces of equipment: a traffic recorder (Fig. 1) in the exchange and Equipment Traffic Analysing No. 2A at the Telephone Area Headquarters. The Equipment Traffic Analysing No. 2A, which is probably better known as the *centralised information retrieval and cartridge update system (CIRCUS)* (Fig. 2), gives Telephone Area teletraffic-engineering staff the means to monitor fully the traffic in each exchange. The equipment is responsible for the control of all traffic recorders within a Telephone Area and the analysis of the subsequent output from these recorders. The CIRCUS consists of a desk-mounted computer with visual display unit (VDU) and printer.

To realise all the requirements of FMTR, it was necessary to introduce a new microprocessor-controlled exchange traffic recorder. The adaptability of microprocessor control has meant that a single basic design of traffic recorder can be used in any of the exchange systems served by the FMTR system. The correct interface to the type of exchange is achieved by equipping the recorder with the appropriate software and interface boards. Although a new traffic recorder has been provided, the pre-FMTR recorder access mechanisms have been used to minimise the capital and installation costs.

The use of microprocessor control has made possible the identification of some exchange-equipment and access-wiring faults, which would previously have gone undetected. The detection of these faults not only provides an additional exchange maintenance aid, but also enables the CIRCUS equipment to adjust automatically the traffic calculations to account for any faults.

One of the major contributions to meeting the objectives has been the introduction of automatic storage and collection of exchange traffic data. This greatly enhances the traffic-recording possibilities by enabling virtual traffic-meter read-

† Local Exchange Services, British Telecom Local Communications Services



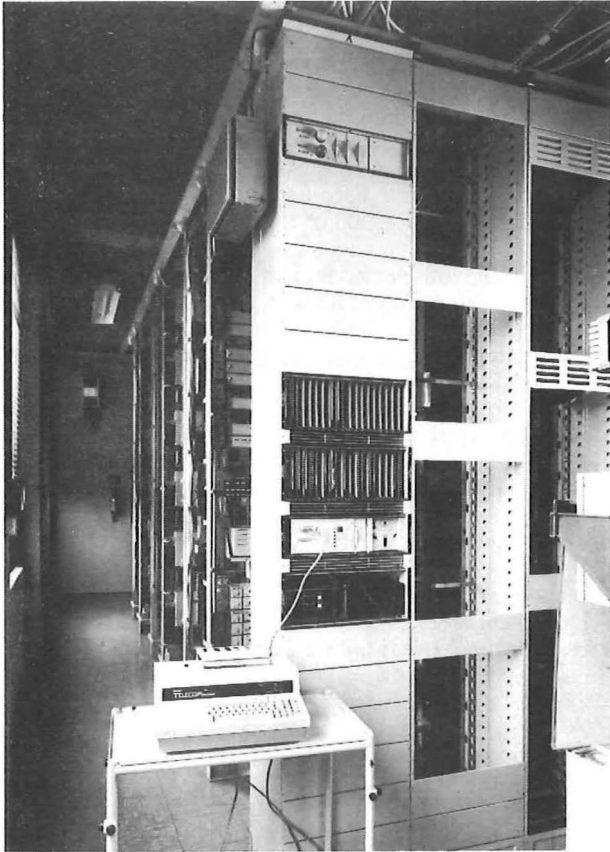

Note: A Transtel terminal is shown in the foreground.

FIG. 1—FMTR traffic recorder (TR8)



Note: The left-hand pedestal houses the Intel chassis and the right-hand the tape unit, Winchester and floppy-disc units. A magnetic-tape cartridge is shown on the desk top.

FIG. 2—CIRCUS unit

ings to be taken every 15 min continuously for several days; it also eliminates the costs and errors associated with the manual collection of data.

### THE FMTR SYSTEM

The FMTR scheme in a Telephone Area consists of a

CIRCUS unit and a number of traffic recorders. In most Telephone Areas, a single CIRCUS is capable of serving all the exchange traffic recorders regardless of the types of exchange being served; that is, TXS or TXE4. Most exchanges require only one FMTR traffic recorder, but larger sites may require up to 5 recorders. If there is an exceptionally high number of these large exchanges in a Telephone Area, a second CIRCUS is then required to handle the load; however, it is anticipated that this will occur in only a few Telephone Areas.

The CIRCUS equipment does not control the real-time operation of the exchange traffic recorder, but merely provides it with exchange information and times of the traffic monitoring periods. The collection and storage of traffic data, and the detection of faults, are controlled entirely by the traffic recorder's microprocessors.

Communication between the CIRCUS equipment and the exchange recorders is via magnetic-tape cartridge. The alternative of communication over a data link was considered but, as no real-time requirement for data transfer exists, the simpler approach of using cartridges to both store and transfer information was adopted. However, the system has been designed to permit the future introduction of cartridge data transfer over data links, outside traffic-recording sessions.

The FMTR system provides new traffic information not only by permitting flexible recording, but also by highlighting exceptional traffic conditions, as follows:

(a) Reports are made on circuits presenting undesirable conditions such as PERMANENTLY FREE, PERMANENTLY BUSY, or spare circuits carrying traffic.

(b) Markers are shown on the final traffic print-out to indicate when traffic levels are either too high to meet the required grade of service, or too low for economic use of the equipment.

(c) An additional set of markers is provided on the print-out to indicate the extent of corrections in the traffic calculations resulting from faults detected in the traffic-recorder access.

The information regarding PERMANENTLY FREE or PERMANENTLY BUSY circuits, spare circuits carrying traffic and access faults is also reported at the exchange for maintenance purposes.

Although the FMTR system is a new traffic-recording system, existing BT methods of traffic monitoring are normally followed; for example, speech or long-holding-time (LHT) circuits are monitored at 3 min intervals, and common equipment or short-holding-time (SHT) equipment at 18 or 12 s intervals<sup>1</sup>.

### Exchange Equipment

There are 2 versions of the exchange traffic recorder, Traffic Recorders No. 8A and No. 8B (TR8A and TR8B), which serve the TXS and TXE4 (RD and 4A) exchange systems, respectively. These variants have been developed to allow for the different methods used by both types of exchange for accessing traffic-recording points. Further information on the TR8 hardware is given later in this article.

As mentioned earlier, the CIRCUS encodes the instructions for running a traffic recorder onto a cartridge, which is then sent to the exchange for loading into the recorder. Once the traffic recorder has been initialised with this information, it runs under its own control, outputting traffic data to the same cartridge. The initialising information required is as follows:

(a) a list of days and times on which the recorder is to run, and the data output frequency (that is, the virtual meter-reading frequency);

(b) instructions on how the exchange traffic-recording access mechanism is to be operated to achieve the correct

scanning of the equipment; and

(c) information regarding each of the circuits it is to monitor (that is, whether it is working or spare, and to which traffic group it belongs).

Up to 4 recording periods per day can be specified, with the length of each period varying from 1 h to 24 h in hourly increments. Recording periods must start on a quarter-hour boundary and be separated by at least a quarter of an hour. The data output frequency to the cartridge can be specified as hourly or quarter hourly. Once this daily pattern has been established, the dates on which this recording pattern is to take place must also be specified; this list of recording dates can cover a span of up to 31 calendar days.

After the traffic recorder has been loaded with this information, it can be left unattended to complete the specified traffic records. When the recorder is running, current drivers within the TR8 activate the exchange traffic-recorder access mechanism every 200 or 500 ms, depending upon the exchange system. Each activation connects a number of exchange circuits to the TR8 for inspection and, if a circuit is found to be BUSY, a software accumulator associated with that circuit is incremented by one. A complete cycle of access selection is completed in 3 min, in which time up to 35 000 or 33 000 circuits can be monitored, depending on the exchange system being served. The access cycle is repeated continuously for the duration of the recording period. Every hour or 15 min, as specified, the contents of all the accumulators are output to the cartridge.

While traffic data is being collected, the recorder monitors the access equipment to locate any faults, and, if any are found, these are reported locally via a terminal and to the CIRCUS equipment via the cartridge. The traffic recorder can be operated under local control to perform a routine test on the access equipment and to obtain information on PERMANENTLY FREE or BUSY circuits, and spare circuits carrying traffic, at times when traffic records are not being taken.

#### *TXS Application—TR8A*

The TXS exchange system was the first to be included in the FMTR scheme. At the time, the power of the CIRCUS was limited by the technology available and, therefore, the TR8A was designed to pre-process some of the traffic data. This took the form of combining the busy counts of individual circuits into their traffic groups, which gives a compact output in a format similar to the traditional meter data. To achieve this grouping, a software look-up table, which lists the accumulators appropriate to each exchange circuit being monitored, is provided. This table, known as the *jumpering schedule*, is loaded into the TR8A by the CIRCUS via the cartridge.

The original traffic-recording access in TXS exchanges is provided by uniselectors, which have been retained for the FMTR system, but which are now stepped under TR8A control. The SHT-equipment access uniselectors are connected to the TR8A individually, but the LHT access uniselectors are connected with up to 8 selectors multiplexed onto a single TR8A unselector input; only one of the 8 uniselectors is allowed to be OFF NORMAL at any one time. By this means, up to 240 uniselectors can be controlled by a single TR8A. The wipers of these uniselectors are permanently connected to the TR8A and interrogated at each selector outlet to determine whether the circuits currently being monitored are BUSY or FREE. Once a unselector has completed a stepping cycle, the busy/free information it has collected is immediately processed by adding the data into the appropriate accumulators associated with the various traffic groups. To prevent overloading the equipment's real-time processing capacity, the uniselectors are not allowed to complete their stepping cycle at the same time, and thereby flood the system with data. This is achieved

by phasing the start of the unselector stepping cycles. The information regarding the timing and sequencing of uniselectors is provided in another data file called the *exchange parameters*, which is again read from the cartridge. The overall stepping requirements for PMTR information are that all LHT uniselectors complete a cycle every 3 min, and all SHT uniselectors 10 cycles every 3 min.

The processing of the data collected by a unselector is delayed until the completion of the stepping cycle, because uniselectors are prone to under-stepping when out of adjustment. While the unselector is stepping, the busy/free data is placed in a temporary store and, only after the recorder has detected that the unselector is on the home contact, after being stepped for a complete revolution, is this stored data passed for processing. Had this precaution not been taken and under-stepping occurred, the recorder would attribute data to the wrong circuits. If a unselector does not stay in synchronism, the stored data is discarded, but the loss of this data is reported on the cartridge to enable the CIRCUS to account for this in subsequent calculations. If a unselector fails persistently, it is automatically taken out of service and the fact is reported to the exchange maintenance staff via the local terminal.

When recording traffic, the TR8A is continuously checking for mechanical failure of uniselectors, or for earth conditions appearing when all uniselectors should be on their home contacts. As mentioned earlier, it is possible to run the TR8A outside traffic-recording sessions to provide maintenance information and other faulting facilities, such as the Liverpool analyser function. Under this facility, data is collected from a single unselector and displayed in a format representing the bank contacts, and from a manual inspection of the data, various wiring faults can be deduced. In addition to these facilities, an automatic routine that checks the stepping of all uniselectors is carried out at 08.00 hours every day.

#### *TXE4 RD and TXE4A Application—TR8B*

FMTR equipment is being fitted in TXE4 exchanges both retrospectively and as original equipment in new exchanges, and must, therefore, be able to support future exchange extensions. To simplify the installation for both initial provision and on exchange extensions, the traffic-recorder software system has been designed to be independent of the allocation of circuits to the TR8B. For example, a rack of junction relay-sets can be connected to the TR8B and tested without regard to the final allocation of junctions to the relay-sets. This flexibility also means that each type of TXE4 rack can be connected to the TR8B in the same manner at all exchanges in the country, so as to reduce the amount of exchange-dependent information on traffic-recorder connections. This information takes the form of an intermediate-distribution-frame (IDF) jumpering schedule, which can now be generated automatically as part of the computerised exchange design. Although the flexibility of jumpering is no longer required by the TR8B, permanent IDF jumpers are provided, as this is the most convenient method of connecting the TR8B to the exchange.

For retrospective installation, some of the existing access jumpers have to be removed and new connections made to the above standard. This re-jumpering is necessary because the pre-FMTR traffic recorder uses a system that monitors circuits in groups of up to 10, and therefore cannot identify the condition of individual circuits. To allow the TR8B to access individual circuits, the grouping provided on the IDF for the old traffic recorder must be removed and new connections made.

To achieve the independence of circuit allocation, and to provide a scheme that would easily accommodate the inclusion of other exchange systems within the FMTR system, the TR8B software does not combine individual circuit data at the exchange. The data collected for each circuit over the

specified interval is output to the cartridge for subsequent circuit grouping and processing by the CIRCUS equipment. The grouping control table used by the CIRCUS for TXE4 exchanges allows a traffic group to be allocated to individual circuits, thus providing complete flexibility of circuit allocation, whereas the equivalent TXS jumpering schedule relies upon a number of consecutively accessed circuits belonging to the same traffic group. The additional memory and processing that this requires places demands on the CIRCUS equipment that could not be met by the earlier design proposed for the TXS application. When the TXE4 application was designed, more powerful proprietary micro-computers, which made possible the further development of the CIRCUS equipment to meet this demand, were becoming available. The collection of non-committed data at the exchange also provides much greater flexibility, since, as explained later, it can be later processed and displayed in many different ways.

There are 2 types of access used in TXE4 exchanges. One is based on a reed-relay matrix and monitors the trunks between the A- and B-switches<sup>2</sup>. The other is based on an analogue scheme and measures circuits in groups, and this serves all other equipment. The latter system is not suitable for the FMTR system and has been replaced by a new system; details of both the old and new arrangements are given in the hardware section later.

While the traffic recorder is running, every 500 ms, 3 drivers within the TR8B are activated. Two drivers energise the A-B trunk access and a third activates the new analogue-type access. The total maximum number of circuits connected to the TR8B by both types of access is 176 per 500 ms (96 analogue and 80 A-B trunk). The status of these circuits is inspected by the TR8B and, if any circuit is found to be BUSY, its personal accumulation is incremented by one. Since the TR8B has direct control of the access, and is, therefore, always aware of the identity of the circuit being monitored, no special provision has to be made for the temporary storage and validation of data.

The information regarding when to activate the particular drivers and where to accumulate the resulting busy counts is provided in a software table. This table, known as the *select table*, is loaded into the TR8B by the CIRCUS from the cartridge. The table consists of 360 entries, one for each 500 ms instant within the 3 min cycle. For each entry, the 3 drivers and the location of the set of 176 accumulators serving the equipment selected by these drivers is specified. Ten and 180 unique sets of accumulators are provided for SHT and LHT equipment, respectively.

When taking a traffic record, the TR8B continuously checks the access for invalid voltages and conditions. With traditional traffic-recording signalling (that is, an earth to indicate EQUIPMENT BUSY and a disconnection to indicate FREE), faults in the access wiring resulting from a disconnection or a contact to the exchange battery cannot be distinguished from a genuine traffic-free condition. The use of the new type of access for the FMTR system has overcome this problem and has extended the fault-finding capabilities of the system. The access is tested every 500 ms just before the traffic data is read and, if a fault exists on an access lead, the reading for the circuit associated with the lead is deemed to be lost for this scan. This fact is recorded on the cartridge to facilitate traffic-calculation corrections, and the exchange maintenance staff informed via the local terminal. The extent of testing on the A-B trunk access is limited, as the traditional traffic-recording signal conditions are used. However, testing every 500 ms prior to the collection of data is still carried out. Additionally, if a fault is detected in this section, recording is aborted, as there is a possibility that the traffic recorder could cause exchange malfunction if recording continues while faulty access equipment is being used. The fault is again reported to the cartridge and to the maintenance staff. It is possible to start the traffic recorder

under manual control to routine the access mechanism and to provide other faulting facilities; for example, individual circuit monitoring with the times of the busy/free transitions being recorded on the exchange terminal.

If additional exchange access equipment is provided, it is possible to monitor a sample of up to 800 individual customers' circuits, thus enabling the generation of information such as class calling rates.

### Equipment Traffic Analysis No. 2A (CIRCUS)

The CIRCUS equipment (version 6) uses software based on the Intel iRMX 86† operating system, and has been designed to support multi-tasking. This allows the operator to give the machine a number of tasks to execute that do not require his constant attention while, at the same time, use it for a separate task that does require his total attention; for example, to edit files. The facilities of the equipment are provided by a number of commands, the most important of which are described in this article. The CIRCUS hardware is described in a later section.

The CIRCUS must provide information for the generation of the national traffic statistics via the PMTR system to the time-consistent-busy-hour (TCBH) standard<sup>1</sup>. It must also provide information purely for local Telephone Area use, known as *SPECIAL information*. As the information collected for the PMTR system is to a set standard, there are very few options offered for the collection and processing of TCBH data. However, if SPECIAL information is required, many more options exist. The 2 main areas of flexibility are, firstly, how the individual circuits are grouped (if at all) and, secondly, the periods over which the data is collected and processed. In the TXS system, both the grouping options and the recording times must be specified before the record is taken. For the TXE4 system, only the running times have to be predefined. This has the advantage that, if a problem is highlighted by the normal TCBH record, it is then possible to investigate the problem further by reprocessing the same data under a different arrangement of circuit grouping.

There are 3 general tasks that must be performed to provide either TCBH or SPECIAL information:

- (a) to initiate traffic records, by creating the cartridges required by the TR8s;
- (b) to process records; and
- (c) to maintain the exchange database files, known as the *master exchange configuration files* and the *alternative exchange configuration files* for TCBH and SPECIAL records, respectively.

#### Initiation of TCBH Records

To produce the cartridges necessary to initiate a traffic record, the DUMP command is used. Under this command, the system copies all the master exchange configuration files relating to the exchange in question to a number of cartridges, one for each traffic recorder in the exchange. All the configuration files for the exchange are copied to cartridges at this stage, even though some are required only for data processing and not for its collection. This is done to ensure that the data collected is subsequently processed to the correct issue of configuration files, and to provide a stand-alone package of data to enable independent processing by the PMTR system, if required. To simplify database maintenance for the operator, files are retained in the CIRCUS on an exchange and traffic group basis. However, during DUMP, these files must be divided and converted into the data structure required by each traffic recorder within the exchange. This is done automatically before the individual traffic-recorder cartridges are generated by cross-referencing between the various files, which also allows checks to be made to ensure that no logical editing errors have been made by the operator when updating files. During

† iRMX is a trademark of the Intel Corporation

execution of the command, the operator is asked to input the times and dates on which the traffic recorder(s) is to run. For security, the DUMP command provides facilities for storing the data files on back-up floppy discs.

#### Data Processing—TCBH Records

To process the data on the cartridges returned to the CIRCUS, the LOAD and PROC commands are used. The LOAD command reads the exchange data and fault files from the cartridge and stores these in the CIRCUS memory. At this stage, the data from TXS exchanges is already combined into traffic groups, but the TXE4 exchange data is ungrouped and takes up considerable memory space. Therefore, during LOAD, the data on each TXE4 cartridge is pre-processed against the grouping table on the same cartridge, and the resulting grouped information is stored with the other data files for further processing. The system prompts the operator to insert new cartridges when required and indicates if any cartridges are missing.

Once the data has been loaded successfully, the PROC command is executed and the traffic information is processed and printed without further operator intervention. The traffic calculations are performed for each period recorded, and corrected to account for any circuit scans lost because of access faults. Then, the data for the equivalent periods in each of the 5 days monitored is averaged to give the general exchange performance at the 4 busy periods. The circuit-group description file is used when the data is printed to provide the support information for each traffic group, such as the critical traffic level for the group, the name and number of the group etc. Various markers are also printed to show the level of correction to traffic calculations and to highlight any traffic value requiring further investigation.

#### Maintenance of Files—TCBH Records

The exchange configuration files used for TCBH records, designated *master files*, are permanently kept within the CIRCUS equipment on a Winchester disc, to provide quick and easy access for editing. Associated with each type of file is an editor, which consists of a set of commands providing the necessary facilities to amend the file contents, such as ADD, DELETE or CHANGE an entry. For example, these commands would be used in the jumpering schedule file to add or delete traffic circuits to or from the FMTR system. It is also possible to produce a printed copy of these files which, in the case of the grouping table and jumpering schedule, can then be used as circuit allocation records.

#### Initiation of SPECIAL Records

To initiate a SPECIAL record, the SPECIAL option of the DUMP command is used. Under this option, the recorder outputs data to the cartridge more frequently, and possibly for longer periods, than in the TCBH case. It is therefore possible that more than one cartridge per traffic recorder will be required to contain all the traffic data. The system calculates the number of cartridges needed from the recorder running times specified by the operator and prompts him as necessary to insert the cartridges for their initialisation.

Under the SPECIAL option of DUMP, the master exchange configuration files are copied to the first cartridge of each TR8, as described for TCBH, but, if the record is to be taken on a TXE4 exchange, the operator has the option of using an alternative select table to that normally used for TCBH recording. For example, a table could be used which specifies that the same access points are scanned every 500 ms throughout the recording period, to produce detailed information on a sample of equipment. If a TXS exchange is involved, an alternative jumpering schedule can be specified which changes the normal grouping of circuits to, for example, a grouping of nil to give individual-circuit traffic data.

Although the system completes and divides the files, as in the TCBH case, only limited checks for logical editing errors can be made, because the files used for SPECIAL records are of a non-standard nature. The security back-up facilities available under TCBH are not automatically provided on SPECIAL working.

#### Data Processing—SPECIAL Records

Again, both the LOAD and PROC commands are used, although options are now provided on how the data is to be processed and presented.

The SPECIAL option of LOAD is very similar to the normal TCBH LOAD, except that the selection of alternative circuit grouping table is now permitted for TXE4 exchanges, so as to provide, for example, individual-circuit data.

The SPECIAL option of PROC offers 2 processing options. Once the initial circuit grouping has taken place, several sets of traffic-group information exist, one set for each 15 min output. For example, if the record was taken over 10 days, each day consisting of three 5 h periods and with traffic data output every 15 min, 600 sets of traffic-group values would exist after the initial grouping process. These sets of traffic-group values can be processed in one of two ways, known as *calculated busy hour* and *extended recording*. The same principle applies to TCBH processing, but, in this case, 20 sets of traffic-group values exist (4 periods per day for 5 days), but no processing options are permitted as TCBH is a standard method of measuring traffic.

It should be noted that, as the PROC command operates on the data loaded and processed by the LOAD command, it is necessary to load the cartridges only once. Any of the SPECIAL facilities of PROC can be used and re-used, without the lengthy process of re-loading the data.

The calculated-busy-hour option of the PROC command is primarily used to determine the most representative exchange busy hours during the 4 quarters of the day: morning, afternoon, evening and night. The processed data collected during each quarter of the day is averaged with the equivalent quarter-hour periods of other days, if any, as specified by the operator. The resulting information is processed further and printed as a histogram representing the total exchange loading at each 'busy hour', and, as the data is collected quarter hourly, a different 'busy hour' is shown starting at each hour quarter. The busiest hours of each quarter of the day are automatically highlighted. A normal TCBH-type record is then produced by using both the highlighted busy hours and the traditional busy hours. The resulting print-out presents the information in such a manner that the performance of the various traffic groups at the 2 sets of busy hours can be compared. The traditional busy-hour times are supplied by the operator, who can also amend the machine-highlighted busy hours, if required. The times of the peak busy hour and the highest consistent busy hour for each traffic group can also be provided, if required.

To extend the use of the calculated-busy-hour facility, the traffic group normally representing the entire exchange can be changed; for example, to the total incoming traffic to the exchange or the traffic loading of a PABX. By this means, a better understanding of the precise traffic-handling performance of various sections of the exchange over the day can be gained. With the additional flexibility offered by the use of alternative grouping tables, any section or configuration of the exchange can be studied during any period of the day.

The extended-recording option of the PROC command is provided to display the processed data of each 15 min monitoring period in a tabular form. One axis of the table is the 15 min intervals of the day, and the other is the days on which recordings were made. The CIRCUS operator can select the days to be averaged and the traffic groups to be displayed; a table per traffic group is provided. A histogram

of the traffic measured over each 15 min interval of the day, or average of several days, is also given.

### Maintenance of Files—SPECIAL Records

The exchange configuration files relating to SPECIAL records, designated *alternative files*, are stored on floppy discs, which can be loaded into the system when required for editing or for providing alternative files during the DUMP or LOAD commands. The alternative files are initially created by amending a copy of the master files.

To utilise fully the flexibility of circuit grouping offered by the grouping-table file, a macro facility has been provided to assist file editing. This enables commonly used sequences of editing commands to be stored, on floppy discs, which can then be automatically executed when required. As the variable data relevant to the commands stored can be supplied when a macro is invoked, a national macro library can be created. For example, a macro could be available to rearrange the standard TCBH configuration of grouping table for TXE4 exchanges, to achieve the detailed analysis of individual A-switches, or provide the link traffic per C-switch<sup>2</sup>.

### Hardware

#### Traffic Recorder (TR8)

The traffic-recorder hardware is based on the automatic call-recording equipment (ACRE)<sup>3</sup>; a general view is shown in Fig. 1. A number of new printed-wiring boards (PWBs) and a backplane have been developed to adapt the ACRE equipment for the FMTR system. Two types of new PWB provide the exchange interface: one to enable the TR8 to drive the exchange access mechanism, and the other to detect the status of the traffic-recording monitoring points connected to the recorder. These 2 types of PWB are known as *drivers* and *highway receivers*, respectively, and, in a fully equipped TR8, 240 driver circuits and 192 highway receiver circuits are provided. To interface to the different types of exchange, the correct version of the driver and highway-receiver PWB units are fitted, and no other hardware changes are necessary. The other extensions to the basic ACRE design are the use of a Transtel terminal to communicate with the system and the provision of random-access-memory (RAM) bank switching. The ACRE uses an Intel 8080 microprocessor, which has an addressing range of 0–64 Kbytes, but this is insufficient for the FMTR system. Therefore, the last 16 Kbytes of addressing range are provided in 3 banks of 16 Kbytes each, and a particular bank is selected by the use of a control port. This effectively increases the addressing range of the system to 0–96 Kbytes.

#### Traffic-Recording Access

The traffic-recording access provided in TXS exchanges is by uniselectors. These are pulsed by the TR8A drivers, but, as high currents are involved, current amplifiers are provided remote from the TR8A on the unselector racks. The highway receiver interprets a nominal earth on the traffic-recording points as a BUSY condition and a disconnection as a FREE condition.

The access provided in a TXE4 exchange is by reed-relay matrices and by an analogue scheme. The control of the relay matrices has not changed and requires pairs of drivers to be activated by the TR8B: one battery driver and one earth driver per pair. However, the analogue scheme has been modified by using different circuitry on the plug-in units installed in the exchange equipment racks for the pre-FMTR traffic recorder; this is shown in Fig. 3, which also shows the original circuit for comparison. The highway receivers monitoring the reed-relay matrix access interpret a nominal earth as a BUSY condition and a disconnection as a FREE condition, while those serving the new analogue

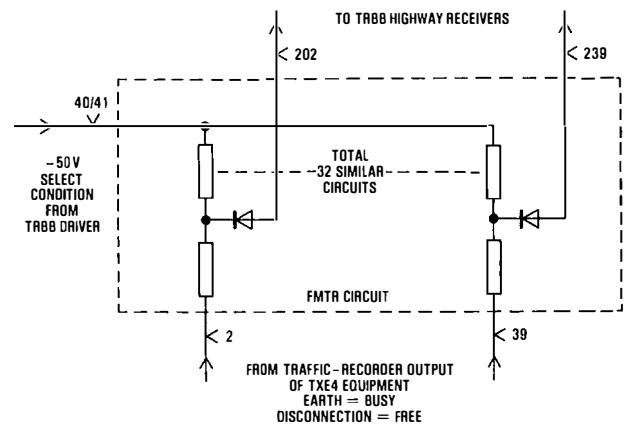

(a) FMTR analogue circuit access provided on plug-in units installed in exchange equipment racks

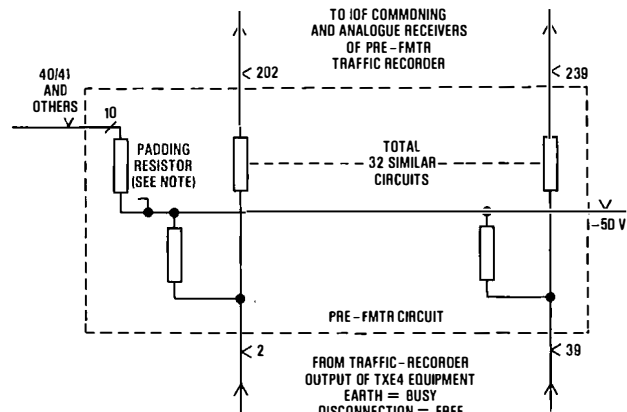

Note: Padding resistors are connected on the intermediate distribution frame to traffic groups of less than 10 circuits to maintain a standard group impedance.

(b) Part of pre-FMTR analogue circuit access provided on plug-in units installed in exchange equipment racks

FIG. 3—FMTR analogue circuit access and original circuit

scheme have 2 reference levels available, which are selected by the software. One level is used to detect whether the circuit has been successfully selected, and the other level to determine the BUSY or FREE status of the circuit (see Fig. 4).

#### CIRCUS Equipment

The CIRCUS hardware consists of proprietary equipment assembled into a desk unit, as shown in Fig. 2. The equipment basically consists of an Intel chassis fitted with a processor board containing an Intel 8086 and an 8087 numerical data processor, memory boards, an intelligent input/output board capable of supporting X21/X25 data communication interfaces, Winchester and floppy-disc controller boards, and a clock board with battery back-up. The

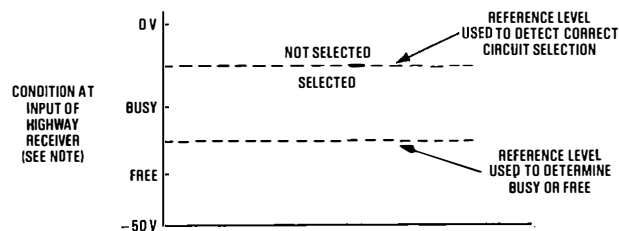

Note: The vertical axis refers to the condition potentials at the input of the highway receiver when a -50 V select condition is applied to an analogue circuit access unit.

FIG. 4—Use of the selectable reference levels provided in FMTR analogue highway receivers

clock is provided to give automatic data issue identification. The chassis unit communicates with a VDU, a printer, a double-drive Tandberg magnetic-tape unit, a Winchester disc and a floppy-disc unit. The VDU and printer are free-standing, but the remaining items are built into the desk. Storage is provided by a 70 Mbyte Winchester disc, 660 Kbytes of RAM and 24 Kbytes of electrically-programmable read-only memory (EPROM). Only a small amount of EPROM is provided to contain the hardware diagnostic and the system start-up software. Once the system is running, various sections of the application software are automatically transferred from the Winchester disk to the RAM for execution as required.

## CONCLUSIONS

Most medium-life TXS exchanges have already been fitted with FMTR equipment and, by early-1984, all Telephone Areas will be equipped to operate FMTR. The TXS programme, which will include more than 500 exchanges, is scheduled for completion in autumn 1984. The installation of the FMTR system in TXE4A exchanges as original equipment has already begun and the retrospective programme in TXE4 RD exchanges is due to start in mid-1984.

The existing traffic-recording system is time consuming

and error prone, and so has not always generated the enthusiasm or provided the means to analyse fully the performance of the telephone network. In the competitive environment of modern communications, it is essential that the utilisation of equipment and the service provided to the customer are carefully monitored. The FMTR system has been developed to overcome the limitations of the existing system and to provide an economic and practical traffic-recording system, which will enable BT to plan accurately for the future and to use its existing equipment to maximum advantage.

## ACKNOWLEDGEMENT

The author wishes to express his gratitude to colleagues in the Local Exchange Services department of BT for their assistance in the preparation of this article.

## References

- <sup>1</sup> GOLESWORTHY, H. M., KYME, R. C., and ROWE, J. A. T. The Measurement of Telephone Traffic. *Post Off. Electr. Eng. J.*, Jan. 1972, **64**, p. 227.
- <sup>2</sup> PAIS, A. F. Traffic Characteristics of the TXE4 Electronic Exchange. *ibid.*, Oct. 1975, **68**, p. 163.
- <sup>3</sup> CANTILLON, W. M. A., and PASHLEY, M. A. Operating with ACRE. *Post Off. Telecommun. J.*, Winter 1979/80, **31**(4), p. 29.

---

# Book Review

*Tutorials in Modern Communications*. Edited by Victor B. Lawrence, Joseph L. LoCicero, and Laurence B. Milstein. Pitman Books Ltd. viii+348 pp. 293 ills. £25.00.

This book is a collection of tutorial articles previously published in the Institute of Electrical and Electronic Engineers (IEEE) Communications Society's magazine. The articles are arranged under the section headings: Quantization and Switching; Data and Modulation Techniques; Computer Communications; Transmission; Signal Processing; and Secure Communications. Each section is prefaced by editors' comments that set the scene and indicate the importance of each of the tutorial subjects. Because of a lack of suitable articles, the coverage is not comprehensive; for example, the topic of differential pulse-code modulation of speech is omitted. The future volumes that are promised will no doubt include articles as they become available.

The section on Quantization and Switching covers the theory of quantization, the digital encoding of video signals, progress in digital switching and the application of integrated circuits in local-exchange line interfaces. The section on Data and Modulation Techniques starts with a review of the evolution of speech-band data communications. The subject of the bandwidth of data signals and spectrum conversation is then followed by articles on the bandwidth-efficient correlative coding and minimum shift-keying techniques; tutorials are included on digital radio, the Viterbi algorithm and fading-channel communications. The section on Computer Communications contains 5 articles that begin with terminology, end with future trends,

and include articles on state-of-the art protocols for local area networks and satellite networks. The fourth section, on Transmission, covers the evolution of digital transmission over metallic cables and the fundamentals of optical-fibre transmission; an article on echo cancellation in the telephone network is included. The section on Signal Processing is dominated by the important topic of digital-signal processing, but it also includes articles on charge-coupled and surface-acoustic-wave devices. The last section on Secure Communications covers topics in cryptography, and includes the National Bureau of Standards data-encryption standard, and spread-spectrum communications.

The flavour of the book is, not surprisingly, very American, although some of the articles do review progress in other parts of the world; the tutorial on digital communications, for example, details the growth of digital transmission and switching in other countries.

The tutorials are all by acknowledged experts in their field and are generally well written. They provide a readable and gentle introduction to subjects which can be difficult to access because they are too new to have become textbook material. Some of the articles contain, of necessity, a mathematical treatment of the subject, but generally this aids rather than obscures understanding.

Although all the articles are available in the IEEE Communications Society's magazine, this book is a helpful collation and should be useful to professional telecommunications engineers, especially those involved in research and development, who wish to keep up to date.

P. F. ADAMS

# High-Level Hardware Description Languages: A New Computer-Aided Design Tool

J. F. BUCKLEY, MA., M.SC., DIC., C.ENG., M.I.E.E., M.B.I.M.†

UDC 681.3.06

*This article briefly outlines how computer-aided design can assist in engineering and other design activities, and goes on to describe the use of high-level hardware description languages in logic circuit design.*

## COMPUTER-AIDED DESIGN

Computer-aided design (CAD), the application of the information processing power of computers to assist engineering and other design activities, is almost as old as computers themselves, and is used in a multitude of fields. While it would be impossible to review so large a topic in this article, it is possible to list some of the ways in which CAD helps designers.

(a) *Draughting* Pictures and diagrams are produced and updated automatically from information input by a designer.

(b) *Modelling* The computer simulates the performance of a design without the designer having to build a working model.

(c) *Checking* A design can be reviewed for conformity with standards and checked for simple mistakes.

(d) *Routine Design* Logically straightforward, but exact and time-consuming calculations are performed by computer.

Computer assistance in a design may vary, according to the difficulty of the operation, across these possibilities:

(a) complete automation of the design function;

(b) partial automation, but needing operator guidance to resolve the most difficult parts; or

(c) low-level assistance with routine functions such as calculations.

Clearly, CAD is computer-*AIDED* design and, ultimately, the human element is the driving and deciding force. The end object of CAD is always to help a designer produce better designs, or quicker designs, or both.

The Alvey Report<sup>1</sup> has identified effective CAD as an essential element in the UK's ongoing information technology developments. The Department of Trade and Industry's (DTI's) CADMAT awareness programmes<sup>2</sup> have been designed to stimulate CAD awareness, not only in information technology, but in many other areas of manufacturing industry. However, this article confines itself to one small part of CAD: that is, hardware description languages (HDLs).

## HARDWARE DESCRIPTION LANGUAGES

HDLs are languages through which a designer of electronic digital logic can describe a circuit. The circuitry described may exist and have been built, or may only be an idea in the designer's mind.

The use of a formal language in the design of digital logic is not new: boolean algebra is a well established logic description system. As long ago as 1968, the language DDL (Digital Description Language) had been developed<sup>3</sup> and this language continues in contemporary use<sup>4,5</sup>. In 1979, Shiva<sup>6</sup> published a list of 43 known HDLs. At present, the main usage of HDLs is to describe completed designs.

† Research Department, British Telecom Development and Procurement

Descriptions are fed into a computer for one or more of the following processes to take place.

(a) *Design Verification Simulation* This is simulation to prove correct operation. It may be used to check basic correct functioning, or it may be used to explore the effects on the circuit of unusual conditions or extreme component tolerances.

(b) *Automatic Generation of Test Patterns* Test patterns are required for testing each and every unit off the production line.

(c) *Fault Simulation* In this process, every possible physical fault is simulated on the circuit, one at a time, to show whether the chosen set of tests will detect them all.

(d) *Testability Analysis* The possibility of achieving a set of test patterns of an economic size may depend on the way the circuit has been designed. Testability analysis can show a designer what parts of the circuit will be difficult to control or to observe.

(e) *Physical Design Tools* Space prevents a detailed exposition of these processes, but they include component parts list extraction, component placement, interconnection routing, and numerical tool control data generation.

A recent example of the use of the description language TEGAS (test generation and simulation) was in the development of System X<sup>7</sup>.

HDLs are likely to grow in importance from now on for 3 reasons. Firstly, the increased use of custom integrated circuits (see, for example, references 8 and 9) makes it important to get the circuit right first time. This is because fabrication costs are high (a minimum of £10 000 for a semi-custom integrated circuit and much more for full custom circuits), and reworks are similarly costly, both in money and in elapsed time. Getting a circuit right first time implies prefabrication testing using simulation and other computer aids.

Secondly, advancing very-large-scale-integration (VLSI) technology<sup>10,11</sup> brings today single chips having 100 000 devices on them, with a promise of 10 million by the end of the decade<sup>12</sup>. Such circuits will be beyond human power to design unless description techniques similar to those already established for handling complexity in software are employed.

Thirdly, HDLs allow design transfer between organisations. Linguistically documented designs can be more safely parcelled out to different contractors to produce (or rework) parts of a total system than with traditionally documented designs, as the description is more precise.

## PRESENT DAY HDLs

Most HDLs in current use are *textual structural* languages. They are called *structural* because they describe structure; that is, they allow a designer to name the components being used and to state how they are connected together. They are called *textual* because the information is expressed in alphanumeric text, rather like a programming language. Fig. 1 shows an example of one such language, HILO2<sup>13</sup>, used to

```

CCT HALFADDER (A,B,SUM,CARRY)

OR (2,2) G1 (W1,A,B);
AND(2,2) G2(CARRY,A,B)
          G4(SUM,W1,W2);
NOT(2,2) G3 (W2,CARRY);

INPUT A B;
UNID SUM CARRY W1 W2

```

FIG. 1—Example of textual structural hardware description for a simple half-adder circuit, using HILO2

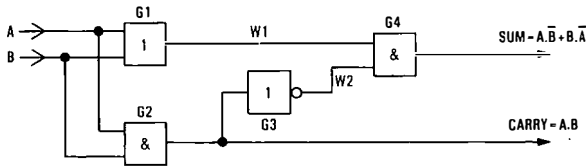

FIG. 2—Diagram of simple half-adder circuit

describe the simple half-adder circuit shown in Fig. 2. The description begins by giving the circuit a name, in this case HALFADDER, and a list of its external connections. There follows a list of components: there is one OR gate given the name G1, two AND gates called G2 and G4, and one inverter, the NOT gate, called G3. The (2,2) indicates that each gate has a propagation delay of 2 units on a rising transition, and 2 on a falling transition.

The connections to each gate follow in brackets, and each wire is given a name. Wire names W1 and W2 have been introduced for internal connections. The output comes first in the connection lists for AND, OR, and NOT. The statements beginning INPUT and UNID declare the wire types (UNID meaning unidirectional).

Although differing in detail, all structural languages are similar in concept.

The gates OR, AND and NOT are called *primitives* of the language because these logic functions are built into the language. In practical applications, designers will wish to use integrated circuits and the language will have a library of predefined descriptions of these so that they can be named and used just like primitives. A useful device library for transistor-transistor logic (TTL) design will contain well over 100 items and represent a considerable investment; for semi-custom IC design, the libraries will be much smaller, around 30 items for a given semi-custom process.

The circuit can be simulated directly from the description in Fig. 2. The process commences with the compilation of the description into a representation of the network within the computer. An event-driven simulator then works from that. The simulator takes its first *event*, perhaps a change on an input wire, and from the network connections works out what other changes have to be scheduled as future events, and when they will happen. This process ripples on, possibly for hours of computer time in realistically sized circuits, until the input changes are all finished and the network becomes stable. The designer has to specify the input changes with which he wishes to drive the simulation by using a waveform language. The output from the simulator will be the logic values on the various wires at different times; these may be displayed in a tabular or a graphical form. Fig. 3 is an example of HILO2 waveform language; Figs. 4 and 5 show tabular and graphic simulation output.

Textual structural languages are neither easy to write nor to understand; they convey little sense or feel for the circuit, and are thus not design aids but rather languages for the capture of designs that have already been produced. Interest is being focussed in the CAD industry on interactive graphics terminals allowing circuit capture from diagrams prepared on the screen of a visual display terminal, and some proprietary terminals and software packages are on the market.

```

WAVEFORM WAVEHALFADD
STIMULUS A,B=0;

10 B=1;
20 A=1;
20 B=0;
30 B=1;

50 FINISH.

```

FIG. 3—Simple example of a waveform language used to generate the input to test the half-adder circuit

---	C	A	SR	UR	MY
0	00	00			
10	01	00			
14	01	10			
20	10	10			
30	11	10			
32	11	11			
36	11	01			

FINISH TIME = 50  
0 SECONDS 33 EVENTS 2 KBYTES

FIG. 4—Tabular output from simulation of HALFADDER

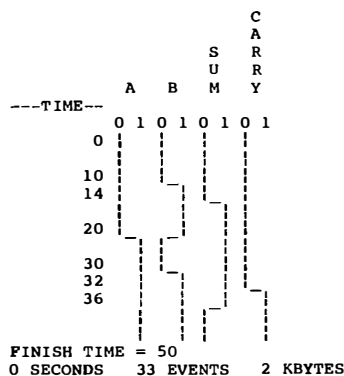

FIG. 5—Graphic output from simulation of HALFADDER

## New Features

The most up-to-date structural languages offer some helpful new features to the designer. The more significant are described below.

### Module nesting

With the module nesting facility, a circuit once described in the HDL can be called by name and used as a 'black-box' module in another circuit. This procedure can be repeated so that a circuit can contain modules, which contain modules, which contain modules, and so on until modules containing only primitives terminate the chain. As an example, Fig. 6 shows a full-adder circuit made up from 2 half adders, and Fig. 7 shows the HILO2 code to represent this.

### Vectors

In many digital systems, wires are grouped into highways; these are collections of wires that have similar and related functions such as an 8 bit data bus. Languages, such as HILO2 allow a vector declaration of a wire; for example, INPUT W [1:4], meaning that there are really 4 wires, W[1], W[2], W[3], and W[4]. Primitives and modules may similarly be given multiple appearances and this greatly reduces the effort of coding certain types of circuit. Figs. 8 and 9 demonstrate this. They show HILO2 code used to make a 4 bit parallel adder by using as a module the full adder circuit shown in Figs. 6 and 7.



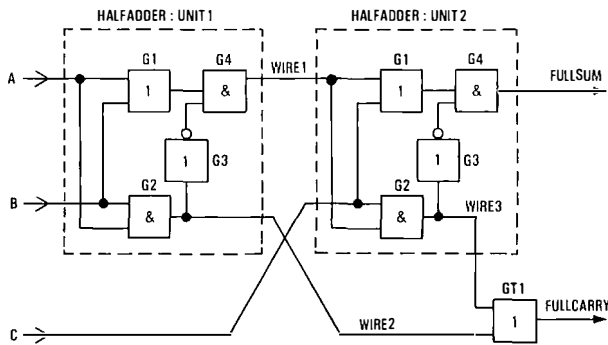

FIG. 6—Diagram of full-adder circuit, built up from 2 half adders

```

CCT FULLADDER (A,B,C,FULLSUM,FULLCARRY)
  HALFADDER UNIT1 (A,B,WIRE1,WIRE2)
    UNIT2 (WIRE1,C,FULLSUM,WIRE3);
  OR (2,2) GT1(FULLCARRY,WIRE2,WIRE3);
  INPUT A B C;
  UNID FULLSUM FULLCARRY WIRE1 WIRE2 WIRE3

```

FIG. 7—Full-adder circuit built up from 2 half adders and coded in HILO2

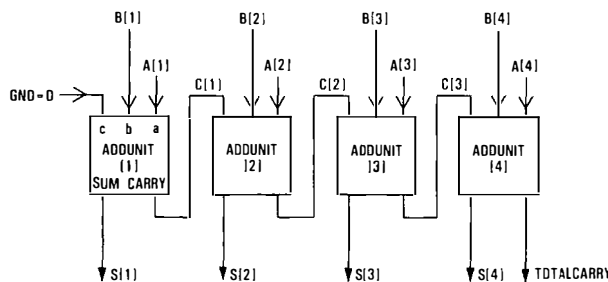

FIG. 8—Diagram of 4 bit binary parallel adder, built up from 4 binary full adders

```

CCT FOURBITADD (A[1:4], B[1:4], S[1:4], TOTALCARRY)
  FULLADDER ADDUNIT[1:4] (A[1:4], B[1:4], {GND,C[1:3]},
    S[1:4], {C[1:3],TOTALCARRY});
  INPUT A[1:4] B[1:4];
  UNID S[1:4] TOTALCARRY C[1:3];
  UNID GND=0;

```

FIG. 9—4 bit binary parallel adder made from 4 binary full adders, illustrating vector facility in HILO2

**Parameters**

Designers frequently need to use a number of modules that differ only slightly; for example, in propagation delay. Languages offering parameterised modules allow a module to be described in terms of a parameter, for example, *HALFADDER (D)* where *D* is an algebraic delay value. All delays within the description of *HALFADDER* would be written in terms of the symbol *D*. When used in another circuit, the module *HALFADDER* would be called with a real value; for example, *HALFADDER (5)*.

**HIGH-LEVEL HDLS**

As stated earlier, a textual and purely structural HDL offers little help in the understanding of a circuit; for this reason most applications are for describing completed designs that

need checking, proving, analysing for testability, or processing by automatic layout and routing software. A newer development is the so-called high-level HDL, with which a circuit can be described in a more abstract way. This allows a designer to describe a variety of circuit ideas and to explore their consequences for operation, timing, and performance, well before proceeding to the more costly and time-consuming stage of full logic design. High-level HDLs are not yet in widespread use, though a number of organisations are committed to their development and use. The first examples of high-level HDLs and their supporting simulators are on the market, and these are the first steps in what may be expected to be an evolutionary development.

**Behavioural Language**

A high-level HDL may be expected to have 2 main parts, a *structural* language like that described earlier, and a *behavioural* language. The high-level description language will have with its structural part a full set of logic primitives, and a device library if necessary. The HILO2 language mentioned earlier<sup>13</sup> is a high-level HDL as it has a behavioural language in addition to its structural language. There now follow some examples of its behavioural language.

**Boolean algebra**

Logic can be described by boolean algebra by attaching algebraic expressions to wire declarations. Thus, the half adder shown in Fig. 1 can be coded by using the statements in Fig. 10. It is also possible to define the logic operation directly by truth table if this is desired, as shown in Fig. 11. This facility is especially useful if most combinations give the same value, as it is possible to specify some cases explicitly, and group the rest under a *DEFAULT* choice.

**Registers**

An element called a *register* can be introduced. A register is something that can store a binary value. It can be vectored to make multi-bit registers. Like wires, registers can have combinational logic permanently attached to their inputs through boolean equations. In addition, however, the language allows a further logic value, or boolean combination of values, to act as an *ENABLING* condition on the gating of the value from the combinational logic into the register; for example,

```
REGISTER R = A AND B LOADIFI ENABLE
```

**Events**

There exists in HILO2 a concept called an event: this can

```

CCT HALFADDER (A,B,SUM,CARRY)
  INPUT A B;
  UNID SUM = A XOR B
    CARRY = A AND B
  Note: XOR means exclusive-OR

```

FIG. 10—Simple half-adder circuit coded by using boolean algebra facility of HILO2 functional language

```

CCT HALFADDER (A,B,SUM,CARRY)
  INPUT A B;
  UNID SUM = VALCASE {A,B},
    00=0, 01=1, 10=1, 11=0
    ENDCASE
  CARRY = VALCASE {A,B},
    11 = 1, DEFAULT=0
    ENDCASE

```

FIG. 11—Simple half-adder circuit coded by using truth table facility of HILO2 functional language

correspond to anything that happens at a defined point in time. There are statements by which an event can be generated, and statements for specifying actions which will occur when an event happens.

To specify the action when an event happens, a statement like this is used:

```
WHEN (event) DO (actions)
```

An event can be *explicit, named, or complex*.

#### (a) Explicit Events

An explicit event is one defined directly in terms of circuit changes, for example:

```
WHEN CLOCK (0 TO 1)
    —a rising edge; and
WHEN CLOCK (? TO ?)
    —any change at all.
```

#### (b) Named Events

A named event is one that can be generated elsewhere in the description. Therefore, WHEN EVENTNAME implies that somewhere else there is a statement EVENTEVENTNAME which can be activated occasionally.

#### (c) Complex Events

Complex events allow sequences and time delays to be specified; for example,

```
WHEN CLOCK (0 TO 1) WAIT 5
    —5 time units after a rising edge;
WHEN CLOCK (0 TO 1) THEN EVENTNAME
    —after a sequence of 2 specified events;
WHEN 5*CLOCK (0 TO 1)
    —after 5 rising edges; and
WHEN 5*CLOCK (0 TO 1) RESET EVENTNAME
    —after 5 rising edges except that an
event EVENTNAME will reset the accumulating sequence.
```

Boolean combinations of events are also permitted; for example,

```
WHEN EV1 OR EV3
```

#### Action at Events

When an event occurs, the statements after the DO specify what happens. Valid statements include the following.

#### (a) Register Transfers

Register transfers set a value into a register; the value can be computed from combinational logic on the contents of other registers; for example,

```
R = (A AND NOT B) OR C
```

#### (b) Event Activation

Named events can be triggered.

#### (c) Conditionals

The basic statements can be made conditional on a logic value; for example,

```
IF (A AND NOT B) THEN EVENT C
```

#### (d) Tabular Choices

A CASE statement can be used to enumerate specific actions depending on some input conditions; for example,

```
CASE {p, q},
00 — R = A,
01 — R = NOT A,
10 — EVENT X,
11 — EVENT Y,
ENDCASE
```

Such a construct is useful for enumerating states in a finite-state machine design.

Despite the apparent resemblance of the statements to software programming languages, it must be stressed that the meaning is quite different. The statements written after a WHEN (event) DO event are scheduled by the simulator to begin concurrently and, together, they all describe a set of actions that is continuously capable of activation at any point in simulated time.

From above, it can be seen how a behavioural language includes operators such as add, and concepts such as event, to let the designer postpone thinking about the detail of these things. Similarly, the definition of connections between modules should allow for a similar abstraction of detail. For example, if a designer wishes to say that a particular signal indicates, say, that a coin value is 2p, 5p or 10p, he should be able to say exactly that, without being forced to determine the signalling code at the same time.

Turning now to a different language, ELLA<sup>14</sup> has a mechanism for specifying interconnections as carrying values other than simple logic values. Fig. 12 shows the first ELLA statements, though not the whole definition, of a hardware module to receive a signal denoting the value of a coin, and to output the cumulative total of money inserted as an integer number of pence from 0 to 999.

### USE OF HIGH-LEVEL HDLS

A typical approach to design using a high-level language might be as follows. The designer starts with a requirement for a system: the requirement can be couched informally in English, rigorously in some specification or mathematical language, or written in the behavioural language as a result of a previous design stage. The designer partitions the system into subsystems, identifies connections between them, and describes the resulting network using the structural part of the language. The behaviour of the subsystems is then described by using the behavioural language. The whole can be simulated for design verification; if necessary, there will be reworks to either the structural or behavioural elements of the design. This procedure is then applied to each subsystem and, in due course, to their constituent modules as necessary. The design then finishes when: the total description including all module definitions is purely structural using only primitives and library elements; the result has been simulated and shown to work; and other constraints such as testability and cost factors have been satisfied.

This is an example of top-down design, essentially a divide-and-conquer approach. A problem that is too large to handle is partitioned into a group of problems, each of which is easier to handle. Applying this approach to a complex system, the designer's first activity would be to postulate some subsystems and identify interfaces between them. The subsystems would be sufficiently rich in their behaviour (that is, complex) that this first step would be intellectually comfortable, and would not require a grasp of the full complexity of the total system.

This procedure can now be applied to each subsystem. If the first stage of partitioning has been performed well, the subsystem designs can be addressed in isolation from one another and, although complex, each subsystem will be less complex than the system of which it forms a part. Indeed,

```
TYPE coin = NEW(two | five | ten | fifty).
TYPE moneytotal = NEW i/0...999.
FUNCTION COINADDER = (coin:input) -> moneytotal:
```

FIG. 12—Heading for module to add up coin values in a vending machine, showing ELLA's capability for defining abstract interconnections

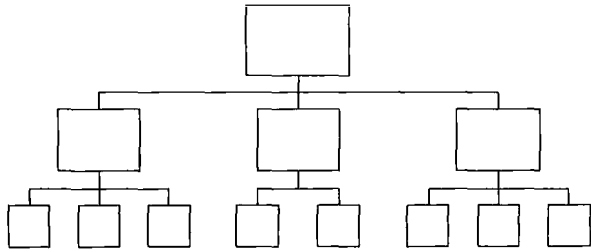

Note: The design commences with a simple structure (one black box) but complex behaviour. Design completes with a complex structure of very simple elements

FIG. 13—Diagram illustrating structure of a complex system broken down into subsystems and sub-subsystems

the approach can then be reapplied to sub-subsystems and so on, until the elements being used become simple; for example, logic primitives. At this point, the system may be said to have been designed. Fig. 13 shows the systematic partitioning of a system.

Many designers will have used these methods consciously or unconsciously for years. Often though, they will have been compelled to follow the entire process through to a laboratory model to see whether the design works. Language techniques allow one design step at a time to be checked by the description and simulation of models of the subsystems, sub-subsystems and interfaces proposed at each stage.

It may be thought that the foregoing discussion is far too simple to represent design activity in the real world. This is indeed true, but the theoretical basis still has value as a means of helping the designer understand what he is doing. For example, in any design, the designer will concentrate most attention on those parts of the design that are most crucial and most difficult. These critical regions may be in the higher levels of systems design (that is in the selection of suitable partitions and high-level interfaces) or they may not. They may lie in the feasibility of achieving a certain performance level in a fundamental component. The designer would expect, in the latter case, to work first on the lower-level components of the design in order to feed back information to enable the higher levels of design to proceed on a sound basis. The top-down framework will have focussed the important questions early.

Economics may force a designer to make use of existing sub-circuits: this may well result in a design less good than could have been achieved with a completely free approach.

It must be accepted that the partitioning process cannot be commenced realistically unless the designer has an appreciation of the materials that will ultimately be used to build the system; that is, their capabilities and their weaknesses. Thus, a chip designer seeking to minimise on-chip interconnect might well select a different partitioning to that of a board designer seeking to minimise component count. When commencing a design leaving open options, the designer must be aware of the decisions that are being deliberately deferred.

Finally, any top-down design may be expected to be iterative. Insights gained as the design proceeds are likely to call for modification of earlier choices of design partition, subsystem function, and interfaces.

### FIRST STEPS IN USING HDLs

The effect on design efficiency and costs of using high-level HDLs will be different, depending on the complexity of the system to be designed. Below a small threshold size, a circuit is so simple that HDL techniques do not help materially. For circuits in the size range of 100 to 10 000 gates, the use of high-level languages may be expected to enhance the chance that the eventual design will be right first time, as it will have been carefully thought through at many levels, proved by simulation in normal and unusual conditions of

operation, and checked for other features such as testability. The overall design time to a viable production item will be shorter because of the reduced number of reworks. It does not, however, follow that the first sample on the bench will be produced more quickly than by traditional methods, and so some designers and their managers may not appreciate the benefits of HDLs at the outset.

For very complex circuits, towards 100 000 gates and beyond, the use of HDL techniques is expected to show clearly visible gains over existing methods. Even if the existing methods can produce a viable design at that size (and this becomes overwhelmingly unlikely as circuit sizes increase towards 1 million gates), it is clear that organisations that do not use the most efficient design techniques will be excluded from full exploitation of VLSI by competitive pressures from those who do.

HDLs are CAD tools that will be new to many organisations. They are seen both as holding the key to the effective exploitation of VLSI technology, and as a most valuable tool to improve design quality and designer productivity for smaller digital circuits. Exactly what features these languages should possess, and how they can best be used by designers, are questions being addressed in research and development establishments at present.

### Acknowledgements

Acknowledgement is made to the Director of Research, British Telecom, for his permission for the publication of this paper. The author wishes to acknowledge the assistance of his colleagues and supervisors in the Martlesham CAD for VLSI project for their various suggestions on this paper. Particular thanks are also due to Tim Thorp of the Royal Signals and Radar Establishment, and Ben Bennetts of Cirrus Computers Ltd. for their comments on the original draft.

### References

- <sup>1</sup> A Programme for advanced information technology—the report of the Alvey Committee. HMSO, 1982.
- <sup>2</sup> BAKER, K. The Department of Industry's CAE Initiatives. *Electronics and Power*, Jan. 1983, **29**(1) p. 10.
- <sup>3</sup> DIETMEYER, D. L., and DULEY, J.R. A digital systems design language (DDL). *IEEE Transactions on Computing*, **C-17**, Sept. 1968.
- <sup>4</sup> SHIVA, S. G. Modular descriptions, simulation and synthesis using DDL. Proceedings of the 19th Design Automation Conference, Las Vegas, June 1982.
- <sup>5</sup> UEHARA, T. DDL Verifier. Proceedings 5th International Conference on Computer Hardware Description Languages and their Applications, Kaiserslautern, Sept. 1981.
- <sup>6</sup> SHIVA, S. G. Computer Hardware Description Languages. *Proceedings of the IEEE*, **67**(12), Dec. 1979.
- <sup>7</sup> HORTH, P. J., and REYNOLDS, R. A. System X: Design and Support. Part 2—Computer-Aided Design. *Post Off. Electr. Eng. J.*, Jan. 1980, **72**, p. 234.
- <sup>8</sup> GRIERSON, J. R. The Use of Gate Arrays in Telecommunications. *Br. Telecommun. Eng.*, July 1983, **2**, p. 78.
- <sup>9</sup> GRIERSON, J. R. Modern developments in gate arrays. *Electronics and Power*, Mar. 1982, **28**(2), p. 244.
- <sup>10</sup> WILSON, B. L. H. Limits to the size of semiconductor devices. *ibid.*, Sept. 1980, **26**(9), p. 704.
- <sup>11</sup> MEAD, and CONWAY. Introduction to VLSI systems. Addison-Wesley.
- <sup>12</sup> MORALEE, D. Visions of the VLSI future. *Electronics and Power*, Apr. 1982, **28**(4), p. 301.
- <sup>13</sup> FLAKE, P. L., MOORBY, P. R., and MUSGRAVE, G. HILO Mark 2 Hardware Description Language. Proceedings of the 5th International Conference on Computer Hardware Description Languages and their Applications, Kaiserslautern, Sept. 1981.
- <sup>14</sup> MORISON, J. D., PEELING, E., and THORP, T. L. ELLA—a hardware description language. IEEE International Conference on Circuits and Computers, New York, Sept. 1982.

# Circuit Provision in the System X Era

P. R. HARRIS, T.ENG.(C.E.I.), M.I.ELEC.I.E.†

UDC 621.395.12 : 621.395.345

*The advent of digital switching and transmission has brought with it a need to introduce quick reliable methods for testing new circuits provided for British Telecom's digitally-switched main network. Research into methods of testing, and the adoption of computer-controlled techniques, have resulted in a satisfactory solution, enabling all types of main network public circuits to be tested prior to the opening of an exchange.*

## INTRODUCTION

As planning of the new digital main switching units (DMSUs) progressed, it became clear that the existing methods of testing new circuits would not be practicable because:

- (a) nearly all circuits presented to the DMSU are in groups of 30 or 31 × 64 kbit/s time-slots, which together form a 2 Mbit/s analogue/digital (A/D) group or a 2 Mbit/s exchange link;
- (b) prior to the opening of a DMSU, access for circuit testing would not be feasible; and
- (c) circuits routed on analogue line plant would be terminated directly onto the analogue line terminating subsystem (ALTS).

These problems have been investigated and a satisfactory solution has been found, which enables all types of main network public circuits to be tested prior to exchange opening.

## CIRCUIT ARRANGEMENTS

When the requirements for circuit testing are considered, the circuits connected to DMSUs fall into 2 main categories:

- (a) digital-digital circuits, and
- (b) analogue-digital interworking (A/DI) circuits.

### Digital-Digital Circuits

Digital-digital circuits interconnecting 2 DMSUs are routed on digital line plant as shown in Fig. 1. For circuits provided prior to the opening of the DMSU, it is necessary for circuit-provision staff to perform only a simple error check on the 2 Mbit/s exchange link. Circuits provided after the opening of the DMSU can be tested by the trunk and junction

routiner (when available) or by accessing the circuit via the test network subsystem (TNS).

### Analogue-Digital Interworking Circuits

Main network A/DI circuits interconnect DMSUs with group switching centres (GSCs), transit switching centres (TSCs) and international switching centres (ISCs), and thus provide the means of communication for customers connected to digital exchanges with those connected to analogue exchanges. As mentioned earlier, access to the DMSU is not feasible prior to opening and, therefore, all testing must be independent of the digital exchange.

In this context, circuits can be divided into those presented to the DMSU on analogue line plant (see Fig. 2) and those to the DMSU on digital line plant; that is, 2 Mbit/s A/D groups (see Fig. 3).

## ARRANGEMENTS FOR TESTING

Circuits routed wholly on analogue line plant can best be tested by connecting a suitable exchange terminating relay-

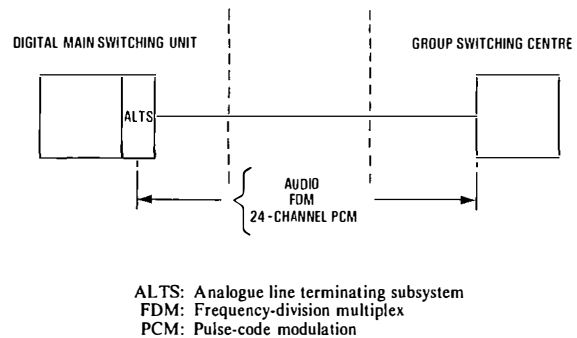

FIG. 2—A/DI circuit analogue presented at the DMSU

† Operations and Maintenance, British Telecom National Networks

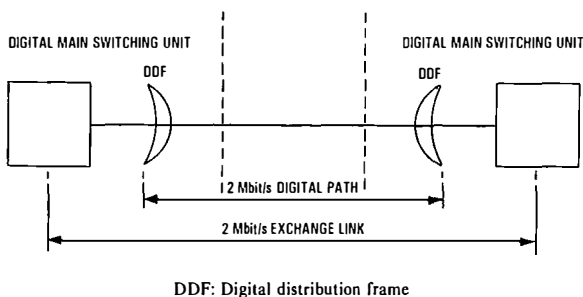

FIG. 1—Digital-digital circuit

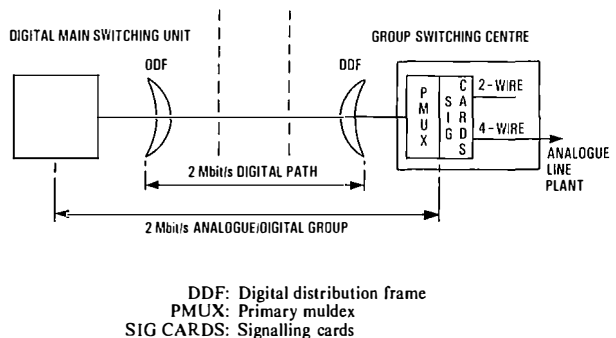

FIG. 3—A/DI circuit digitally presented at the DMSU

set at the nearest practicable point to the DMSU. In practice, the circuit is intercepted at the test jack frame (TJF) and an exchange terminating relay-set patched in; testing is then carried out as for a normal analogue circuit.

Circuits terminating at the DMSU on digital line plant require a different approach. The 2 Mbit/s A/D group, consisting of up to 30 circuits, appears as a 2 Mbit/s HDB3† encoded digital stream at the digital distribution frame (DDF) and, to test an individual circuit, it is necessary to extract the relevant 64 kbit/s time-slot. This can be achieved by connecting:

(a) a primary muldex (PMUX) at the DMSU DDF and inserting the appropriate signalling card (the circuit is now analogue presented at each end and may be tested as such); or

(b) a digital analyser and simulator at the DMSU DDF, and using it to extract the appropriate 64 kbit/s time-slot and test through the GSC PMUX and signalling card circuitry, to avoid the digital-to-analogue conversion at the DMSU.

Method (a) was used initially, but suffered from the disadvantage of the testing engineer having to transport a large and heavy PMUX from one exchange to another. Furthermore, additional test equipment—for example, audio oscillator, level measuring set and, in some cases, a portable AC9 relay-set—was required.

A project to evaluate the merits of method (b) was undertaken. Preliminary investigation pointed to the possibility of using a computer-controlled system which could be updated as and when required to take account of future developments; the system would also have the advantage of being easy to operate without the need for the user to have previous computer experience. The Marconi Instruments' digital analyser and simulator (DTS 1B) was chosen as it offered most of the required facilities, including a general-purpose interface bus for computer control. The computer used throughout the project has been a PET Commodore 4032. During the course of development, it became clear that several modifications to the DTS 1B would be needed to maximise the use of computer control. With the full co-operation of Marconi Instruments Ltd., the modifications were carried out, and the test set was recoded DTS 1C.

The DTS 1C can select any 64 kbit/s time-slot from the 2 Mbit/s stream; it can then send and receive the digital equivalent of audio tones at a variety of frequencies and levels. Alternatively, it can send and receive information in time-slot 16 (TS16). The use of computer control means faster operation and an improvement in facilities over manual control. Figs. 4(a) and 4(b) show the test arrangements.

### COMPUTER SOFTWARE

Five programs are available covering functional testing of circuits terminating on voice-frequency (AC9), TS16 and multi-frequency (MF2) signalling systems at analogue exchanges. The language used by the PET is a version of BASIC. This language is relatively easy to learn and, although execution is much slower than machine code, it has proved itself capable of meeting all requirements. Each program contains a mixture of user communications, including screen captions (instructions, information, prompts, test results etc.), control of test equipment (setting up simulator parameters, interrogating analyser etc.) and mathematical calculations to convert test results into meaningful information. All programs have been designed to give as much help as possible to the user, and experiments show that, once the circuit-provision engineer is able to load a program from tape cassette, no previous computer operating experience is neces-

† HDB3—High density bipolar 3

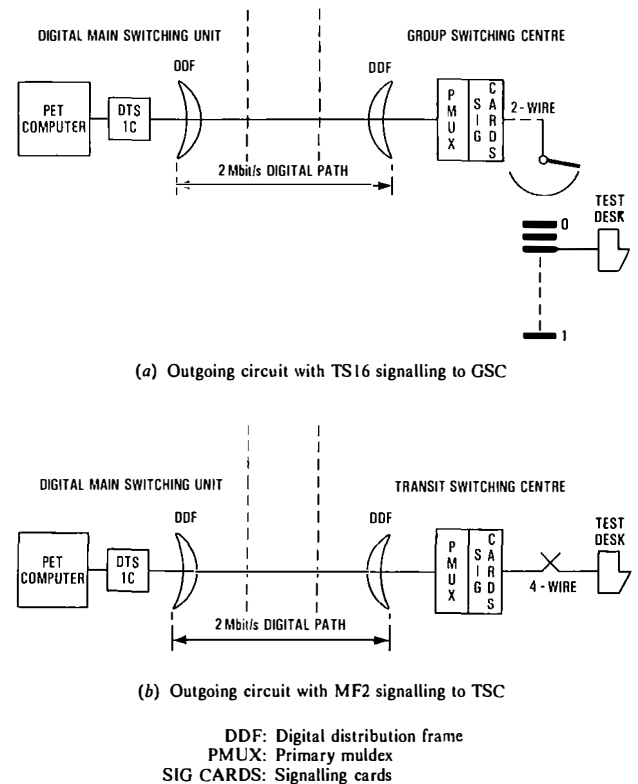

Fig. 4—Testing arrangements for outgoing circuits from a DMSU

sary for circuit tests to be carried out.

Control of the DTS 1C is achieved by a number of subroutines, each of which performs a single control function. Each program contains those subroutines necessary for its correct operation, and these are called up as and when required. After execution of the subroutine, control reverts to the main program.

### TESTING AN OUTGOING TS16 CIRCUIT FROM A DMSU

On receipt of the RUN instruction, the computer displays on its visual display unit (VDU) a series of introductory frames prompting the operating engineer to check test-equipment connections, control settings etc., followed by a request to establish telephone contact with the test clerk at the distant trunk maintenance control centre (TMCC). The computer then requests information on the TMCC incoming-test-access-circuit loss and the transmission-test-circuit dialling code. A call is set up under computer control from the DTS 1C to the TMCC incoming transmission test circuit. Called subscriber answer (CSA) is detected by the computer and a request made for an audio tone at a specified frequency and level to be sent from the TMCC. On receipt of this tone, the received level and permitted tolerances are displayed on the VDU and a tone is returned to the TMCC with a request for measurement of its level. After measurement of the level, the TMCC test clerk clears the circuit. The clear is detected by the computer and an indication appears on the VDU.

### CONCLUSIONS

Combining computer technology with modern test equipment has made it possible to produce an equipment package capable of performing adequate functional tests on all types of main network circuit currently expected to be provided during change-over from analogue to digital switching. This equipment can be used by circuit-provision staff with no previous computer operating experience, the necessary instructions being contained on one A4 sheet of paper.

# Equipment Cooling for Modernisation

W. G. BROWN, B.SC.(ENG.), C.ENG., M.I.E.E., M.C.I.B.S., C.DIP.A.F†

UDC 621.395.7 : 697.97.005

*Over the past few years, it has become increasingly necessary to use refrigeration to cool the air that ventilates modern apparatus rooms. Because of the high capital costs of large central installations, British Telecom has developed a small self-contained cooling unit. This article describes the operation of this cooling unit and shows how a modular approach allows the provision of cooling capacity to be matched closely to the requirements of the apparatus room.*

## INTRODUCTION

The amount of heat given off by modern telecommunications equipment has increased over the years and it has become increasingly necessary to chill the air that ventilates apparatus rooms. The basic method of cooling by drawing fresh air into an apparatus room, distributing it through ductwork to diffusers over the equipment racks, and allowing it to escape via pressure relief ventilators, as shown in Fig. 1, is seldom satisfactory. The use of fresh air alone to cool rooms with high heat concentrations would cause draughts because of the amount of air needed.

In the past, refrigeration plant has been used by British Telecom (BT) to reduce the amount of air required to extract the high levels of heat dissipated by telecommunications equipment (see Fig. 2). Refrigeration plant located in a central plant room produces cold water, which is pumped to the cooling coils of air handling units (AHUs) sited near the equipment served. Warm air from the apparatus room is drawn into the AHU where it is chilled as it passes over the cooling coil before being fed back into the apparatus

† Energy, Transport and Accommodation, British Telecom Local Communications Services

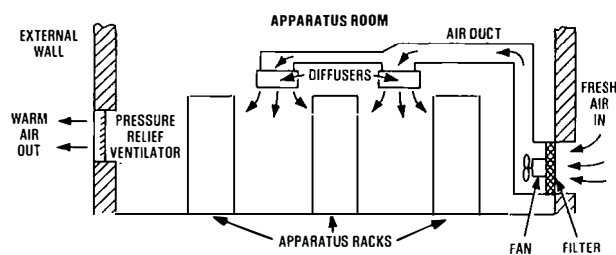

FIG. 1—Exchange cooling system using fresh air and old-style air distribution system

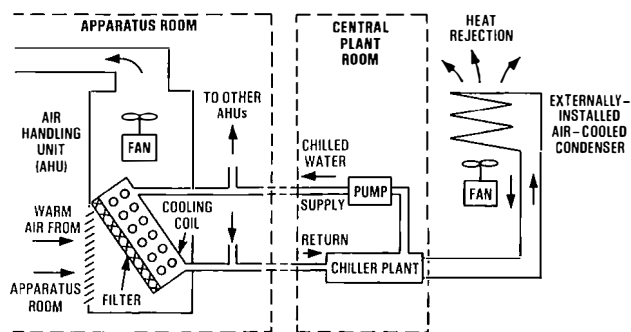

FIG. 2—Exchange cooling system using a central water-cooling plant

room via the ductwork. The heat extracted from the air stream is transferred from the cooling coil to the air-cooled condenser in the central plant room and discharged into the atmosphere by fan cooling.

Reliability is achieved by the costly duplication of main items of equipment, often sized to satisfy the 20-year forecast of requirement.

## SYSTEM X REQUIREMENTS

With the advent of System X, it was decided to develop a 15 kW standard cooling unit, which would be self-contained, and which could be provided on a modular basis within the apparatus room. This arrangement would allow the cooling capacity to be extended by the provision of additional units during the life of the exchange, defer the cost of the ultimate cooling requirement, and negate the need for a central refrigeration plant room. Also, by providing a minimum of 2 units with a small excess capacity, on failure of any one air handling unit, the apparatus-room temperature could be limited to the maximum safe-working temperature of the exchange.

Evaluation of meteorological data for the UK showed that, for a typical installation, a simple fresh-air system would suffice for over 70% of the year, and give high reliability and maximum economy in running costs, with chilling being required only in warm weather or in high absolute humidity conditions. The BT standard cooling unit was developed to combine these features and to be capable of controlling the apparatus room to  $24^{\circ}\text{C} \pm 3^{\circ}\text{C}$  within a maximum relative humidity of 70%.

## THE BT STANDARD COOLING UNIT

The BT standard cooling unit is designed to operate without a central refrigeration plant or remote condenser. It contains all its own refrigeration plant and associated controls.

The unit, rated at 15 kW, is designed with a wheel-outer inner section that contains all necessary equipment except the main circulating fan and control card. This ensures a short unit repair time and hence contributes to a high system reliability. Fig. 3 shows the general arrangement of the unit.

One of the significant features of the unit is that only a very short installation period is required. Provided that the appropriate hole in the wall has been made, the outer casing of the unit can be pushed into position by 3 or 4 men and connected to electrical power supplies. The inner section can be rolled in, and plugged into the outer section; the unit is then ready for operation. No detailed commissioning checks need to be carried out because these will have all been undertaken at the factory (see Fig. 4). A brief functional test has been developed to ensure that the equipment has not been damaged in transit.

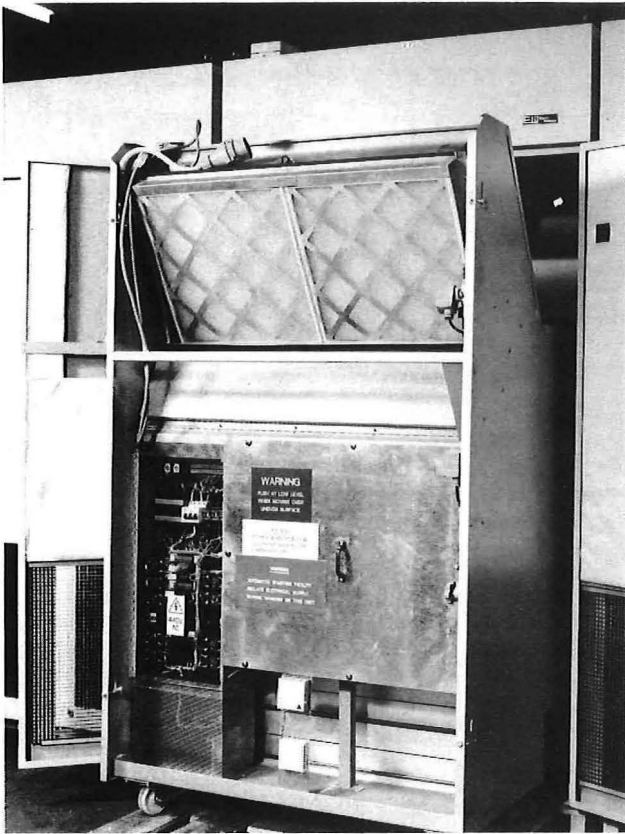

FIG. 3—BT standard cooling unit

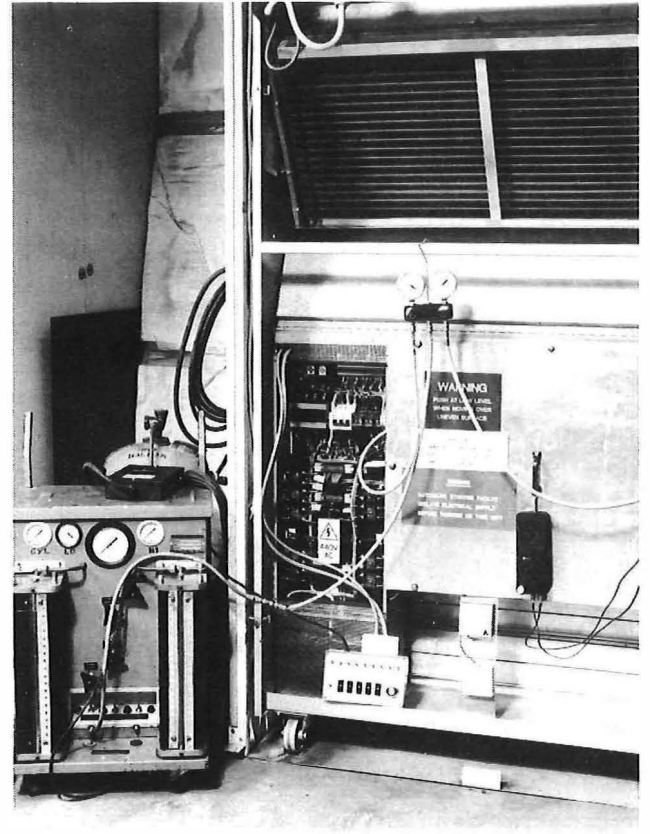

FIG. 4—Charging the Cooling Unit 1A/15 kW with refrigerant gas at the manufacturers works

When outside ambient air conditions are favourable, air is drawn in from outside the building, passed through the filter, and then into the apparatus room by the main circulating fan (see Fig. 5). Temperature control in this free-cooling mode is maintained by the damper being moved to regulate the mixture of fresh air and warmed return air. Any surplus return air from the exchange escapes through a pressure-relief ventilator built into the bottom of the unit. The

pressure-relief ventilator has an airflow/pressure-drop characteristic that ensures a small and almost constant positive room pressure regardless of the amount of fresh air being drawn in, and thereby prevents the ingress of unfiltered air into the exchange. When the outside air is no longer capable of maintaining the required exchange ambient conditions, because of high temperature or relative humidity, the damper reduces the air intake to a small quantity required

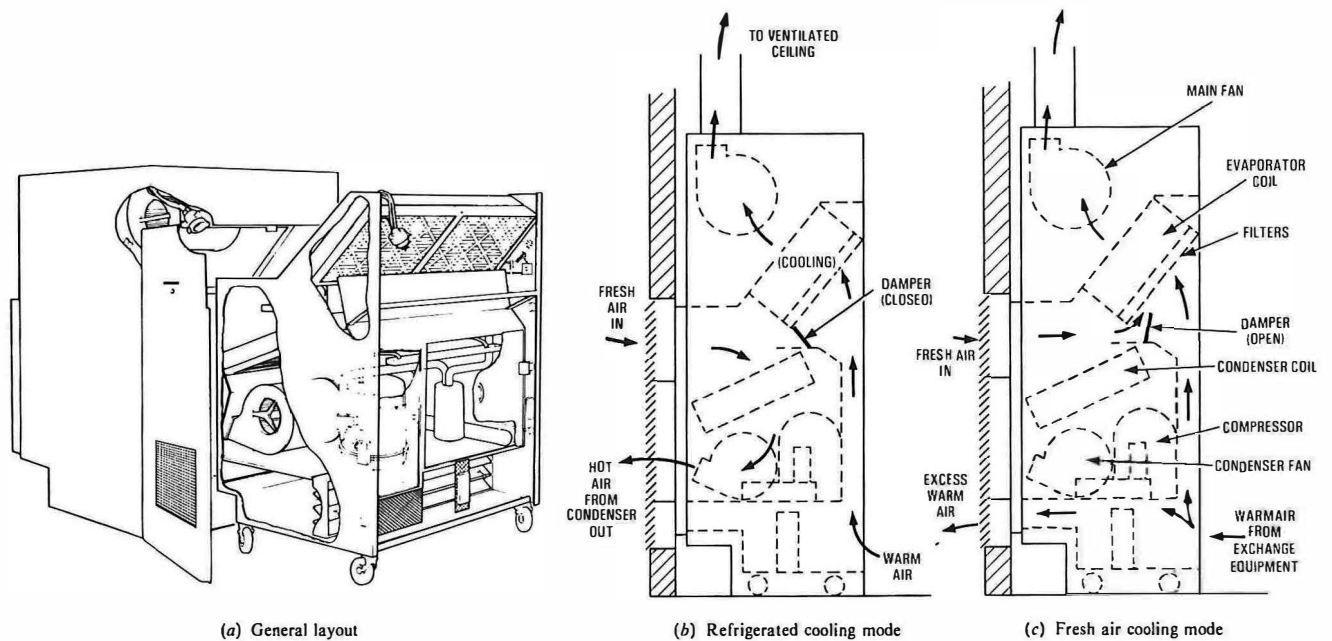

FIG. 5—Operation of standard cooling unit

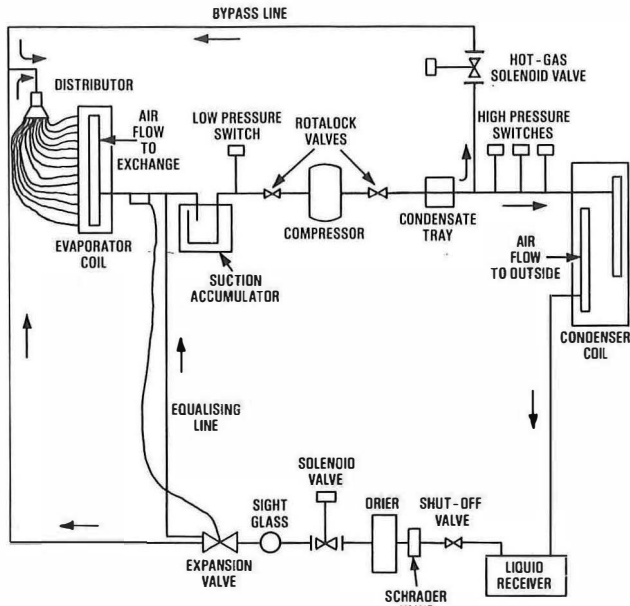

FIG. 6—Refrigeration arrangements of the BT standard cooling unit

for pressurisation purposes; the refrigeration system starts up and continues running until outside air conditions are again suitable for fresh-air cooling.

### THE REFRIGERATION SYSTEM

A block diagram of the refrigeration system is shown in Fig. 6. A signal from the control card starts the compressor, which begins to pump refrigerant gas in the direction of the arrows. The action of compressing the gas causes its temperature to rise. As the gas enters the condenser coil, it gives up its latent heat to the air and, in so doing, cools and leaves in a liquid form. It then passes through the expansion valve and into the evaporator coil, where it absorbs the heat from the air circulating round the apparatus room and changes from a liquid to a gas. Temperature control is aided by a hot-gas bypass line, which varies the cooling capacity by allowing a small part of the hot gas from the compressor to mix with the normal liquid refrigerant entering the evaporator. By opening and closing the hot-gas solenoid valve in this line, a reasonably steady room temperature can be maintained. A liquid receiver in the main circuit ensures a steady supply of refrigerant to the evaporator, and a suction line accumulator prevents liquid refrigerant reaching the compressor and causing valve damage. Condensate from the evaporator is collected in a tray fitted round the hot-gas pipe as it leaves the compressor; this is rapidly heated and discharged to atmosphere in the condenser airflow.

### MAINTENANCE

One of the difficulties with central plant systems has been the problem of repairing and maintaining large chillers. These tasks require the use of skilled refrigeration engineers who are difficult to recruit under existing BT staff career structure arrangements. Most large chillers are made in the USA and spares for them can take 6 months, or even a year, to obtain. Clearly, a system with such a long fault repair time must have a very low reliability.

The BT standard AHU has been designed so that any major component can be replaced within one hour. The inner section can be replaced within a matter of minutes and this ensures that involved repair work does not have to be carried out in the apparatus room. The compressor, which is the main refrigeration component, is a fully-sealed non-repairable item costing approximately £350 and does not require skilled attention (see Fig. 7).

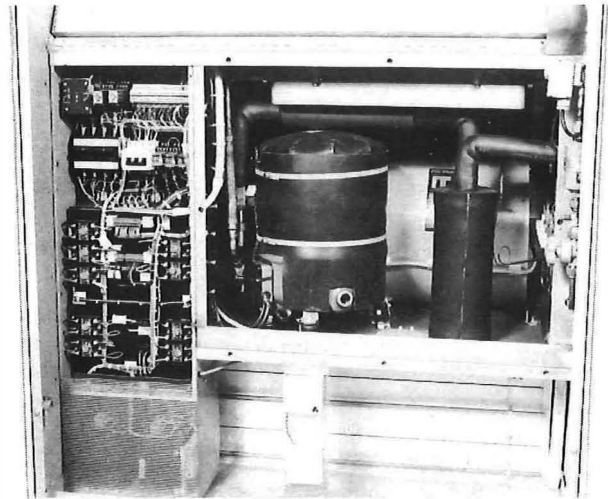

FIG. 7—Compressor unit

The equipment has been built so that it can be wheeled round the free areas in a System X apparatus room. New or replacement inner sections can be wheeled onto site, rolled into the outer casing, plugged in and switched on.

### CONTROL SYSTEM

The standard cooling unit is controlled by the Control Card 1A (see Fig. 8); a simplified control diagram is shown in Fig. 9.

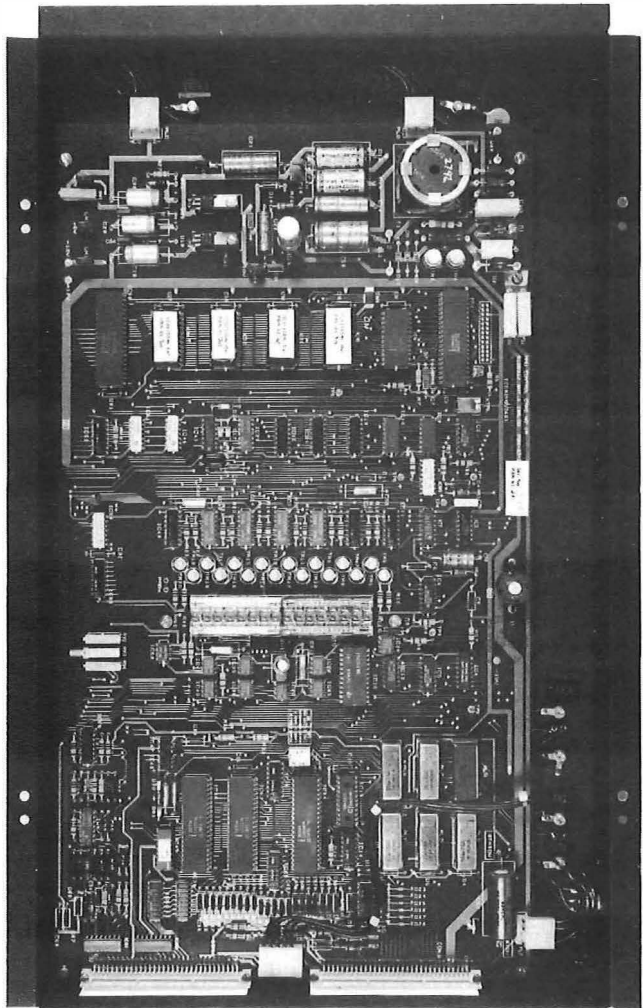

FIG. 8—Control Card 1A



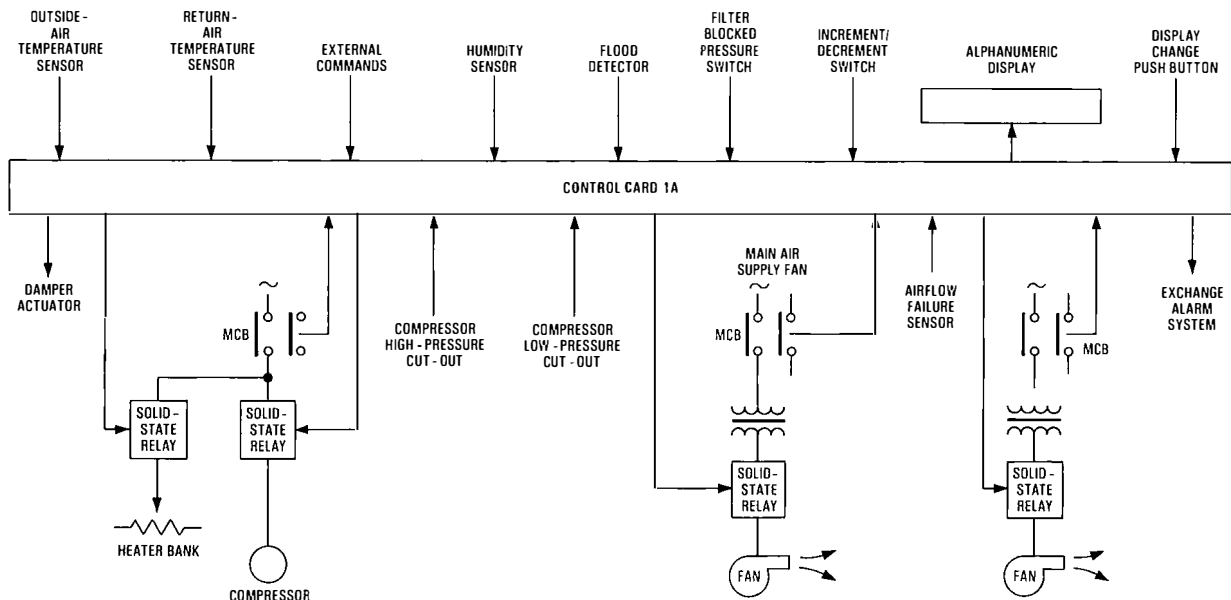

FIG. 9—Simplified control diagram

The control card, the heart of which is a microprocessor, has 2 functions:

- (a) to provide control signals to all the working components within the cooling unit, and
- (b) to initiate alarm signals in the event of component failure or abnormal operation.

The most important input signals are derived from the outside-air temperature sensor and the return-air temperature sensor. These are platinum film resistance thermometers, which enable the microprocessor to decide whether it is necessary to turn on the refrigeration plant. When initially switched on, the card automatically tries to maintain the temperature of the air returned to the unit at 24°C, by operating the damper under proportional-plus-integral control and admitting outside air as required. The proportional action determines the sensitivity of the damper response, while the integral action minimises the offset or small angular error that would be present each time the damper moved to a new position. If the outside conditions are unfavourable and it is no longer possible to maintain the return air within the preset limits, the control card initiates a signal to close off the outside air and turn on the compressor or heater bank. Return air conditions are then maintained either by burst-fire control to the heater bank or by operation of the refrigeration plant. A similar situation occurs when the relative humidity in the exchange reaches 70%.

Communication with an operator is made by using a 16-character alphanumeric display mounted on the card. A single push button on the card allows the operator to read sequentially a number of constantly updated legends, such as relative humidity, return-air temperature and damper position. Under fault conditions, such as a high-pressure condition in the compressor, the control card initiates a signal that shuts down the compressor, extends an alarm to the central alarm system and overrides any text on the display with the flashing legend HIGH PRESSURE. By pressing the push button, the alarm is accepted and, if the fault condition has cleared, the compressor is allowed to restart.

There are several timers, which are all controlled by the microprocessor's 6 MHz crystal:

(a) *Delay Start* The delay-start timer is intended to prevent a number of cooling units being connected to the mains/stand-by power supply simultaneously and thereby creating a large current surge. Each unit can be set to start at a different time ranging from 10 to 120 s after switch on.

(b) *Compressor Timers* The compressor is controlled by 2 timers, which are both fixed in duration. The first of these prevents the compressor from starting for 4 hours after power is applied initially; this allows the sump heater to warm up the compressor crankcase and boil off any liquid refrigerant; failure to do this could allow the compressor to pump liquid and cause valve damage. The second timer prevents the compressor starting twice in less than 10 minutes; this inhibits it from exceeding 6 starts per hour, as recommended by the compressor manufacturer, and ensures that the compressor motor does not have a shortened life as a result of overheated windings.

(c) *Airflow-Failure Sensor* When the main fan is first switched on, it takes some time to run up to speed and establish an airflow. A timer is therefore incorporated to inhibit the airflow-failure alarm for a period of 15 s.

(d) *Hours-Run Indicators* Two indicators record the number of hours in operation, one for the compressor and the other for the unit as a whole. The data is stored and can be displayed for maintenance purposes.

A single-pole double-throw toggle switch with a centre OFF position is provided to allow certain parameters such as temperature set point, integral time, proportional bandwidth and delay-start time to be increased or decreased in value. In order to retain these parameters when the 50 V supply is disconnected, the control card is equipped with a 1024-word electrically-alterable read-only memory (EAROM).

## APPLICATION

Theoretically, it would be possible to distribute the chilled air in an exchange by the diffuser system shown in Fig. 1. However, because of the higher heat concentrations created by System X equipment, very high air velocities would be required from the diffusers and this would produce unacceptable draughts for maintenance staff. It became increasingly obvious during the development programme that the method of air distribution for System X exchanges should be similar to the types used in computer installations; namely, ventilated-ceiling systems or free-blow systems, where the only control over distribution is by means of a discharge grille in the top face of the unit.

With the free-blow system, an adapter on top of the unit directs the chilled air horizontally over the top of the equipment racks; the warm air rises from the equipment and mixes with this air to create the correct mean room temperature.

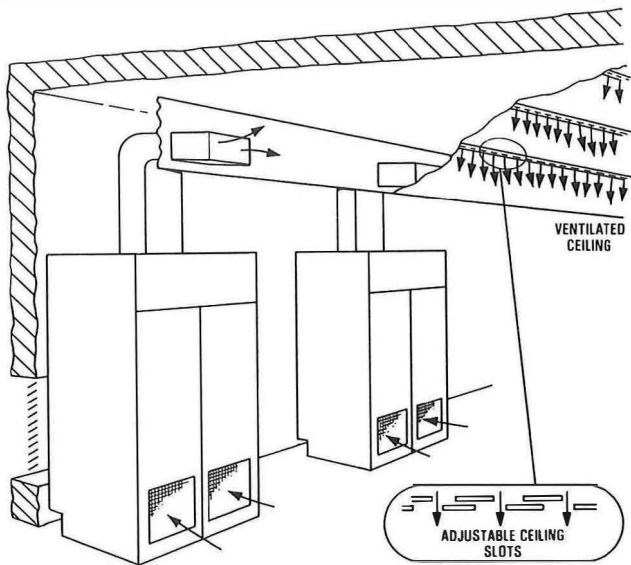

FIG. 10—Common ventilated-ceiling system

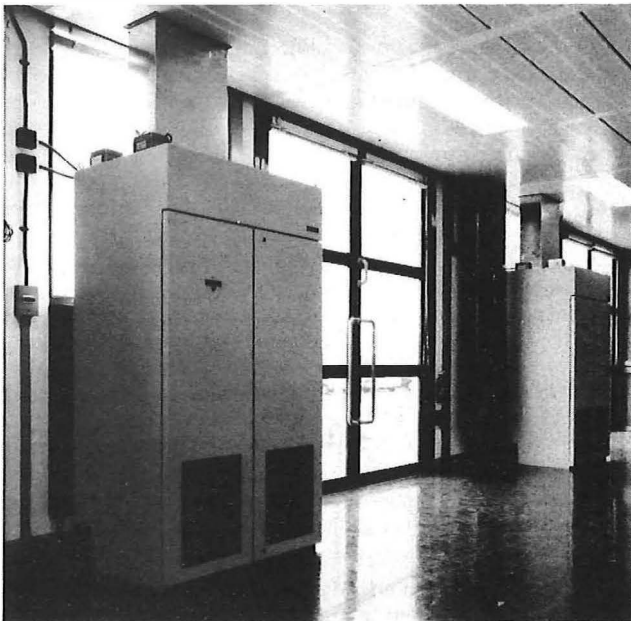

FIG. 11—Standard cooling units feeding air into common ventilated ceiling

The ventilated-ceiling system feeds chilled air from the units into a void above the equipment. The chilled air pressurises the void, but is allowed to escape through a large number of small slots. To cater for varying heat loads, a ventilated ceiling with adjustable slots is used, rather than a fixed pattern of perforated holes (see Figs. 10 and 11). The slots are blocked off over the area where little or no heat is being dissipated in order to allow more cold air to be discharged over racks with a high heat dissipation. The jets of cold air mix with the warm rising air to form an acceptable room temperature. This permits:

- (a) ceilings to be adjusted from below, where cable racks prevent access to the ceiling, and
- (b) reasonably high velocities of air leaving the slots, so that good mixing is achieved with the warm rising air.

These methods of air distribution are preferred to the alternative system where cold air is fed into the bottom of the equipment and creates draughts round the feet of maintenance staff.

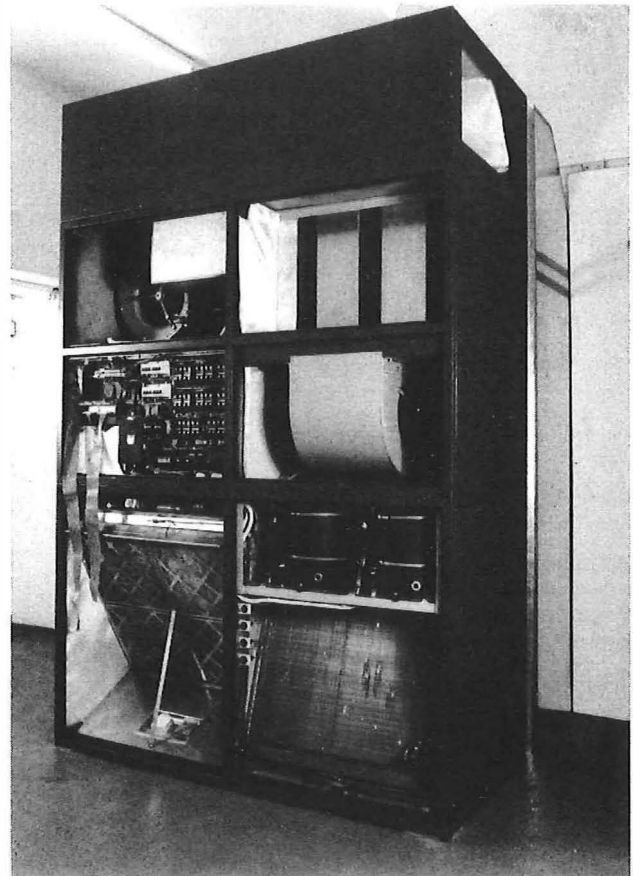

FIG. 12—30 kW cooling unit

#### FURTHER DEVELOPMENTS

Cooling units of 7 kW and 30 kW capacity, which are similar in principle to the 15 kW unit, have now been developed. The 30 kW unit does not have a removable inner section because it would be impossible to move such a large item of equipment, or manoeuvre it around apparatus rooms with safety. It has, however, been designed as a set of easily assembled components, which can be moved individually around an apparatus floor. It uses 2 separate refrigeration circuits and 2 compressors that are identical to those used in the 15 kW unit (see Fig. 12). Apart from spares-holding considerations, this also allows some form of capacity control and enables the unit to run at 50% duty in the event of a failure of one of the refrigeration systems.

A 32 kW unit, which operates from a chilled-water system, is available. This unit is intended for use in buildings where there has already been a heavy capital investment in chilled-water plant, which can meet the future reliability requirements of the exchange. A modified unit with a direct expansion system is also available for use with remote condensing sets.

All the units are capable of being controlled by the same Control Card 1A.

#### CONCLUSIONS

The use of standard cooling units represents a radical departure from earlier exchange cooling systems. The units are highly reliable, and installation and running costs are low. The control system is technically in advance of anything currently available on the commercial market.

The system has been designed to have the flexibility to meet the present and future requirements of System X, electronic (TXE4/4A) and Strowger switching equipment, transmission equipment and other systems that may be introduced in the future.

# Parcel Traffic Recording—TRIPOS

H. R. HENLY, C.ENG., M.I.E.R.E., and R. I. HARCOURT, B.SC., C.ENG., M.I.E.E.†

UDC 656.882 : 656.851

*This article outlines the need for improved traffic recording of parcel traffic and highlights the particular problems of introducing such equipment into a wide range of conditions in existing parcel sorting offices. The article then describes the traffic-related information in parcel offices system—TRIPOS—which has been developed to solve these problems.*

## INTRODUCTION

The Post Office parcel service is a commercial concern, which is in competition with the private sector. As in any commercial operation, there is a need to know the volume of product being moved, at all levels of the organisation, national, regional, and local. Nationally, for marketing purposes, traffic figures are required to see that campaigns are effective, and to indicate how the market is changing. Finance Department requires figures for accounting purposes. Each region must organise transport within the Region and to other regions. Local management must see that the sorting operation is effective, and that despatches of abnormal volume have revised transport arrangements.

In 1979, in a report to the Board Member for Finance, the Post Office Auditors, Touche Ross, called for better parcel traffic figures. Parcel traffic data was collected from a variety of sources, principally electromagnetic counters on sorting machines and various sampling methods. These methods are expensive and of dubious accuracy. Studies showed that, not only were the counters themselves inaccurate, but they could also be mis-read. Furthermore, the process of reading counters manually was costly and a diversion from the task of controlling the sorting office. The Engineering Department of the Post Office was therefore sponsored to develop automatic traffic recording equipment.

## HISTORY

In 1980, equipment was designed to enable the problems of data collection to be studied in an office environment. This equipment was known as the *digital recording equipment* (DRE), and it was installed for a trial period at Southampton Parcel Sorting Office. The DRE relied on an off-line computer to analyse traffic figures via punched tape, and was thus restricted in the amount of information that could be handled. The installation enabled various techniques for counting parcels reliably to be assessed. However, because access to the central computer was limited, and manual intervention was still required, a further development of a traffic recorder was sponsored, using a dedicated computer.

## BACKGROUND—PARCEL SORTING MACHINES

Parcel sorting is carried out mostly by using parcel sorting machines, which are usually of the tilted-belt variety. These comprise a conveyor belt, tilted at 37° to the vertical, which runs the length of the office. Parcels are placed on one end by a sorter, who presses one of 50 buttons on a keyboard, to determine from which of 50 outlets the parcel will emerge. A parcel-sorting-machine controller takes the electrical signal from the keyboard and times each parcel on its journey along the tilted belt. When the parcel is adjacent to the selected outlet, the outlet door is actuated by electrical means, so that gravity causes the parcel to slide off the belt into a chute.

The total number of parcels placed on the belt is counted by a photo-electric cell, and is known as *gross* traffic. The

total to each outlet is counted by counting the key depressions on the keyboard for each outlet. Some parcels do not emerge from a door; instead, they travel the length of the belt and emerge from the end into a parcel stream known as *recirculation*. This term is used because the parcels are returned by conveyor back to the input of the machine. The main factors causing recirculation are:

(a) *blockages* the required outlet is blocked with parcels awaiting staff to clear them for despatch;

(b) *no codes* the sorter does not press a key to sort the parcel; and

(c) *cancel keys* the sorter cancels his selected key by using the CANCEL key.

All remaining reasons for recirculation are lumped together as a discrepancy; this includes machine malfunction, problems caused by high friction, and other minor factors.

Because a photo-electric counter beam is placed at the end of the belt, which counts the *recirculation*, it is possible to compute the *nett* traffic, by the sum

$$\text{nett} = \text{gross} - \text{recirculation}.$$

This is called *nett* because recirculated parcels have to be returned to the start to be re-sorted, and so it represents the effective work done, the total work done being indicated by *gross*. In order to attribute cause to the recirculation, the sum

$$\text{discrepancy} = \text{recirculation} - \text{blockages} - \text{cancel keys} - \text{no codes}$$

can be done. Then, the percentage of recirculation arising from each factor can be determined. A modern trend is to package parcels in plastic film, which is shrink-wrapped around the parcels. This has a high friction in certain conditions of humidity, and can cause a high *recirculation*, making *discrepancy* high. Thus, by watching the *discrepancy* figure, management can be aware of such factors and can take appropriate action.

## TRIPOS

Computerised equipment, known as *TRIPOS* (traffic-related information in parcel offices system), was developed. (See Fig. 1.) This uses a mini-computer, which provides automatically printed reports suitable for management, and on-demand information for sorting-office floor supervisors. A major problem in the development of this system was the large variation in the type and nature of the plant in the parcel sorting office. In particular, the sorting-machine controllers (see Fig. 2) use various technologies depending upon age, ranging from electromechanical pin-wheels to modern microprocessors; this means that there is no standard interface to TRIPOS. In addition, it was considered desirable to write one piece of software that would be suitable for all 25 sorting offices.

## Configurable Software

To accommodate the various configurations of sorting equip-

† Engineering Department, Post Office Headquarters



FIG. 1—TRIPOS installation at Leeds PCO

ment, the software for TRIPOS is written in 2 parts: the TRIPOS on-line system, and the off-line configuration program (CONFIG). To install TRIPOS in a new office, the CONFIG program is used to place data arrays on a magnetic disc. In operation, TRIPOS takes these data arrays from the disc to determine the configuration of the office. Such items as the name of the office, and the number and layout of the sorting machines, are made known by the CONFIG program through answers from its operator to simple questions phrased in English. In this way, the user of TRIPOS sees from the printed output the correct destination names, machine names, and operating times of this particular office. There is no coded computer jargon output from TRIPOS. In addition, the CONFIG program has made it possible to configure the input cabling by permitting the identity of each cable to be made known to TRIPOS. Thus, if there is any error in cabling, it is possible, by using the CONFIG program for a few minutes, to make corrections that would have taken days or weeks to correct physically.

### The Hostile Environment

Parcel sorting offices contain large quantities of heavy-electrical machinery, which is continually being switched on or off by contactors or heavy-current relays; these are located adjacent to TRIPOS. The collapse of electromagnetic fields when a motor or contactor-coil current is switched off causes high levels of energy to be radiated electromagnetically. In keeping with common practice in such an environment, TRIPOS connections make use of 50 V logic to ensure high noise immunity. In addition, wherever the computer is connected to the plant, use is made of opto-isolators, which provide high common-mode rejection. Serial data links in the plant (such as printer leads) make use of 20 mA current signalling.

### TRIPOS Interface

The connection of the TRIPOS computer to the plant is known as the *interface*, and it can take one of two forms, depending upon the nature of the plant. Where a microprocessor controller is used to control the plant, a single current-loop pair can be used between TRIPOS and each controller. Where the controllers are not based on mini- or micro-computers, many hundreds of pairs of wires are required instead. This is because the data can be serialised or time-division multiplexed where a controller is based on a processor, but must otherwise be divided across space. For the



FIG. 2—Parcel-sorting-machine controllers adjacent to the TRIPOS installation at Leeds PCO.

serial link, data is checked using parity bits and check-sums for validity. For the multiple-wire case, each wire is scanned 3 times and, only when the sequence 0, 1, 1 is detected, is a valid parcel signalled to the software. This scheme removes noise pulses from further consideration. The extra cost of the multiple-wire solution can provide justification for replacing obsolete controllers with processor-based controllers where TRIPOS is required, so that the cheaper serial data links can be used.

### Software Organisation

TRIPOS software is organised as tasks within a real-time multi-tasking operating system; a block diagram is shown in Fig. 3. By using this scheme, the many asynchronous processes occurring in the plant and in the computer can be synchronised onto a single processor and a single memory. An important requirement of the software design is that, as far as possible, the software should be machine-independent and thus portable. The advantage is that the type of computer used for development need not necessarily be the same type as that used for production.

The most portable compiler available is FORTRAN IV which, although not block-structured, is a mature and highly portable language. CORAL could have been used, but it is a primitive language with no input/output procedures, and input/output is used extensively in TRIPOS; also, many manufacturers do not support CORAL. The disadvantage of FORTRAN IV (and of FORTRAN 77 as well) is that DEFINE FILE, which is required to structure the disc data files, is an extension of the language and is non-standard. This is the only aspect of the TRIPOS analysis software that would require to be re-written for another machine. The front-end scanner task for the plant interface is written in assembler for speed of operation and simplicity of interfacing to the operating system. This would naturally have to be re-written for another machine, but represents only 5% of the total software package.

### TRIPOS Facilities

Facilities include traffic reports printed automatically on-demand, and weekly to a magnetic medium which could be disc or tape. The magnetically coded data is intended to be posted to a central computer to provide national statistics. Where immediate information is not required, this is cheaper than sending electronically by using modems. Later, TRIPOS could be networked to send immediate details of despatches to the receiving offices.

Reports are printed automatically at the end of the shift or operating plan, at the end of the day (daily summary), and the week (weekly summary). These include gross traffic, nett traffic after taking account of recirculation, and a

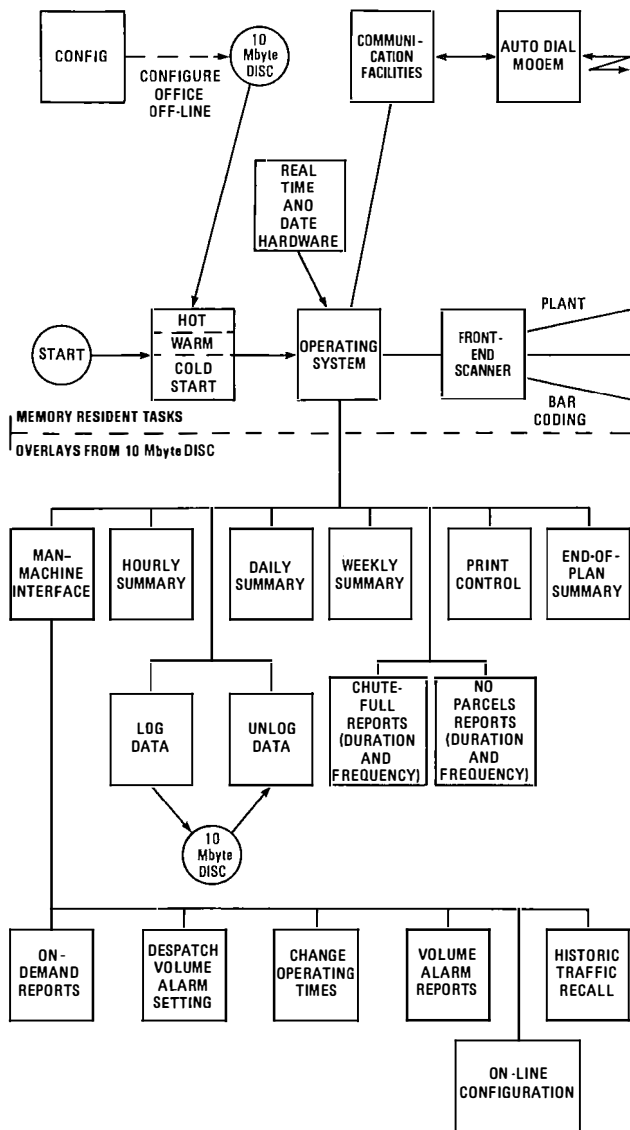

FIG. 3—Block diagram of TRIPOS software task organisation

breakdown of reasons for recirculation. Other automatically printed reports are: totals to destinations on the output of the machine; times for which outlets were full; and times for which no parcel was available for sorting. Reports are also available on-demand; this feature is for the office manager's use to see in advance whether despatches require re-scheduling or transport needs re-arranging.

### CONCLUSION

A field trial of parcel traffic recording using TRIPOS was carried out at Leeds Parcel Concentration Office (PCO) from July 1982 to March 1983. This equipment is now being used operationally for day-to-day management of that office. Two further TRIPOS systems have also been installed in two new offices opened in mid-1983 at Watford and Glasgow PCOs. Development of TRIPOS is continuing with the design of a national parcels data collection system that would combine TRIPOS data with data from bar-coding bags and Mail All-Purpose Trailer Equipment (MATE). Such a system would gather both traffic and quality-of-service data; thus, for the first time, the Post Office would have all the available facts about the parcel service in an accurate and immediate form.

If TRIPOS is adopted nationally, there are many future possibilities. The architecture of the mini-computer lends itself to extension to a computer network, feeding information almost instantly to all sorting control centres. In this

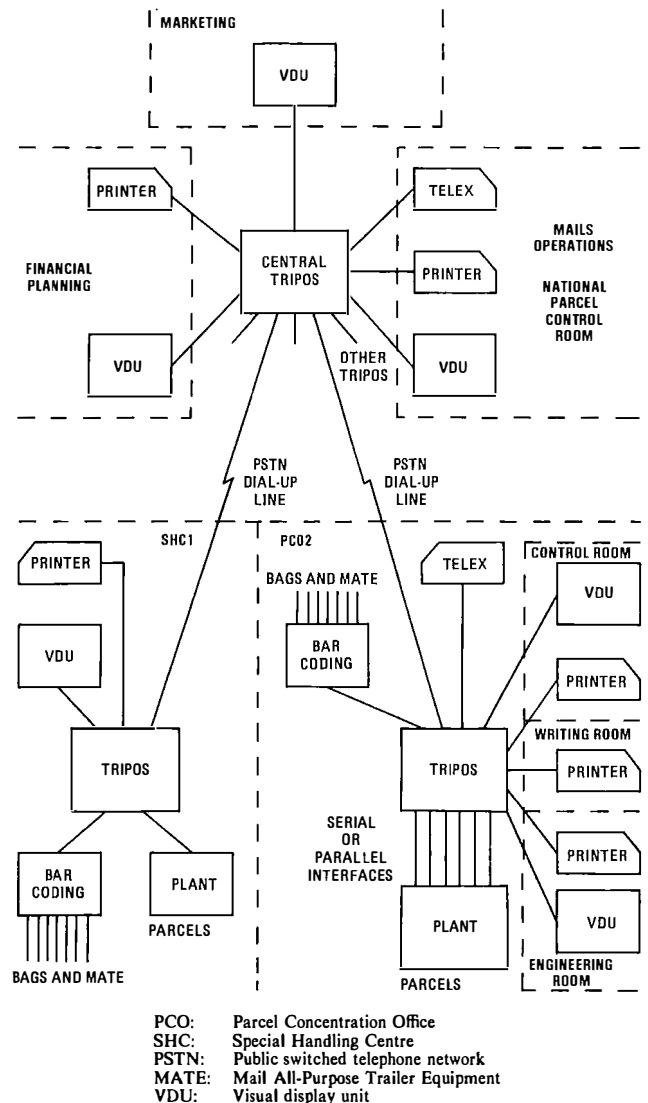

FIG. 4—Future potential of TRIPOS

way, all major sorting offices would have a prediction of their next day's traffic so that work could be better planned. The national parcel control centre would be able to control the network in real-time, instead of reacting days or weeks later, after a crisis had passed. Instant re-routing around bottlenecks would be possible, and network planning could be based on accurate recent information. If vehicles were added to TRIPOS as a traffic item, then the fleet could be better controlled, and questions relating to the location of all the parked trailers could be answered immediately. If parcel bags and MATE containers are added by using bar-coding, the bulk mail traffic and quality of service of these trunk routes could be accurately reported to those in control, so that quality of service could be improved. An appreciation of the possible scope is given in Fig. 4.

The Post Office is setting up new Special Handling Centres, to provide an additional parcel service for large and heavy parcels. TRIPOS can be used in these centres, as well as for conventional parcel handling.

It is in the belief that information technology (IT) should be used for better control of the operation by management that TRIPOS is being developed. This use of IT is not only advantageous in its own right, but also gives the Post Office experience and leadership in this important technology.

### ACKNOWLEDGEMENT

Acknowledgement is due to the Director of Engineering, The Post Office, for permission to publish this article.

# SEQUIN—A Computerised Information System for Enquiry Operators

D. R. EWERS, F. BENNETT, and G. PAYNE†

## INTRODUCTION

As the result of the installation of a new computerised information system, known as the *system for enquiry update and interrogation (SEQUIN)*, enquiry operators at Reading auto-manual centre (AMC) no longer have to thumb through grubby dog-eared record cards to obtain the information they require to assist customers. The operator accesses the information by keying the national number (less the initial 0) on a numeric keypad; the information is displayed on a 127 mm (5 in) visual display unit (VDU).

## BACKGROUND

Enquiry operators need to know the state-of-line information on every telephone number parented on their AMC. This information was previously held on record cards, with each card holding the information for 400 telephone lines. Nearly 180 000 telephone numbers were parented on Reading AMC, and the total was increasing; as the wells in the enquiry positions were unable to hold any more cards, something had to be done.

In addition, a great deal of time was required to maintain the 8 complete sets of cards, which were amended from the information contained on advice notes. As Reading AMC handles over 1000 advice notes a week, the job of amending and replacing the cards was irksome and repetitive. Even in the best regulated and supervised system, such circumstances can lead to errors.

## COMPUTERISED SYSTEM

It was felt that a computerised system would be a great improvement for all those concerned. After consultations with trade unions and the Area Computing Services of British Telecom's Data Processing Executive (DPE) in October 1982, British Telecom, in October 1982, a Casu Mini C computer with floppy-disc unit was installed on the end enquiry position as an experiment. The computer was programmed with information relating to Henley telephone exchange, which had a 7000 numbering range comprising 4- and 5-digit telephone numbers and a mixture of business and residential lines. The information was input and amended by clerical staff, and the enquiry operators took it in turns to operate the system. The reaction to the prototype was sufficiently favourable to proceed to the next stage of the experiment.

Two Plessey Multi-user System 19 (MUMP) computers were ordered. Each machine has two 35 Mbyte Priam hard-disc drives, a Perex high-density magnetic-tape drive and a single-sided single-density floppy-disc drive. The machine is capable of supporting up to 14 users, but the configuration used for this application restricted each machine to 12 operators' or clerks' terminals. Each user is served by a Z80A processor giving 64 Kbytes of random-access memory (RAM) and running CPNOS. The master (or controlling) processor gives 128 Kbytes of RAM, but this is generally



FIG. 1—Enquiry-operator position at Reading AMC equipped with a SEQUIN visual display unit and keypad

not available to the user as it runs MP/M2. A software interface called *CPNET* handles communications between CPNOS and MP/M2. (A Digital Microsystems (DMS) HINET version of the SEQUIN is also available.)

In order to overcome space constraints at the operators' positions, a 127 mm (5 in) terminal, specially developed by KGM Electronics Ltd., is used (see Fig. 1). This terminal is interesting because the controlling electronics and power source are installed on racks remote from the terminal. This means that each terminal is no larger than the cathode-ray tube, and the difficulties of providing mains supply to the enquiry positions is overcome as the terminals are run from a 20 V supply distributed from the rack. A numeric keypad for interrogating the main file is supplied at each position.

The first computer was delivered during January 1983 and, after DPE had supplied the software, an Assistant Supervisor (D) was trained to use it; she also prepared the operating instructions and trained the clerical operators. The information was input from the cards but, because these did not differentiate between business and residential customers, one set of cards had first to be annotated with the business details. The bulk input program was written so that 10 numbers at a time are displayed on the screen in the same order (1-0) as one line on the cards. The program also remembers the last screen input and follows on from that point automatically to avoid inputting the information twice. The clerical staff found the programs easy to use and soon became proficient. The clerical staff use full-size

† Mr. Ewers and Mr. Bennett are with the Reading Telephone Area, British Telecom, and Mr. Payne is with the Area Computing Services, Data Processing Executive, British Telecom Headquarters



FIG. 2—Information from advice notes being inputted at a SEQUIN clerk's terminal

Newbury Laboratories 8009 VDUs, which are fitted in the clerical room for all inputs and amendments (see Fig. 2). The small VDUs and control rack were delivered during June 1983, and the enquiry operators started to use the information operationally during July 1983.

### SOFTWARE

The DPE software is written in COBOL and fully utilises the FILESHARE package written by Microfocus to allow concurrent access to the main files. The software was generally ready on time but, more importantly, DPE has always been prepared to alter and amend programs in the light of experience and, of course, to give assistance when difficulties arise. Programs provided by DPE include the following:

(a) *Bulk Input* This is used to input the information on each telephone line during the initial setting up. The program automatically identifies any line that has no other comment beside it as a working line, which indicates that it is a residential customer.

(b) *PBX Input* As PBXs have more than one line, and the second and following lines are not necessarily consecutive, the details on PBXs are input by using a special program which differentiates between Strowger, electronic and crossbar exchanges. Also, one screen of information input could write between 2 and 999 lines depending on the size of the PBX.

(c) *Amendment* This is the program that is used for daily changes to the state-of-line information when advice notes are received. Separate sections of amendments are available for PBXs.

(d) *Print* The 3 print programs available provide the following:

- (i) a listing of a particular number range;
- (ii) a 'before and after look', which is used to check that amendments have been input correctly; and
- (iii) a print-out of the PBXs in a particular range.

(e) *Check* This program runs overnight to check for corruption of the main files.

(f) *Update* This program amends the information in the main file from the information input during the day.

### STATISTICS

A software package is being designed that will produce the information required to compile management statistics as well as other useful information.

### BACK-UP

One of the main objectives in designing the system was to provide as much back-up as could be provided economically. Enquiry operators provide a 24 h service, and the system has to do the same. DPE, therefore, introduced the following contingencies:

(a) Two Plessey MUMP machines are used, and both have copies of the files and software. The machines run simultaneously, and both have operator terminals linked to them. If one machine fails, the other carries on working and provides a restricted, but effective, service while the fault is being repaired.

(b) Two copies of the files are maintained in each computer in case one is corrupted. The copy of the file can be brought on-line within minutes of the corruption being detected.

(c) A complete copy of the files is output to a magnetic-tape cartridge once a week, and the cartridges are stored in a safe place. These copies can be used to restore the files if a disastrous failure occurs.

(d) The computers and control rack have access to the exchange's stand-by generator power.

### CONCLUSION

As with many experiments, there have been teething problems with the introduction of the SEQUIN at Reading AMC, but these have always been overcome with the assistance of DPE. Plessey engineers have always been prompt to visit and repair faults when they have occurred.

Since introducing the system in Reading AMC, DPE have produced a version capable of running on a DMS HINET multi-user computer, and are currently installing it in Chelmsford AMC. A Newbury Laboratories stand-alone 127 mm terminal is being used in this installation. DPE are also making plans to install the system in Ascot AMC, a cordless exchange.

Finally, it should be made clear that the introduction and trial of the SEQUIN has been undertaken with the full agreement of the trade unions concerned.

# New Transformer / Rectifier Units for the Post Office Railway

R. E. FINDEN, C.ENG., M.I.E.E., P. PIQUÉ, and K. KETTRIDGE†

UDC 621.311.4 : 621.33 : 621.314

*The Post Office Railway carries over 40 000 bags of mail each day beneath London's streets, along some 10 km of tunnels. The electrically operated trains are automatically controlled and carry no drivers or passengers. This article describes the modernisation of the power plant used to supply the traction power to the trains.*

## INTRODUCTION

When the Post Office (PO) Railway entered service in 1927, the power supplies were derived from bulk 6.6 kV 3-phase AC supplies from the then private electricity generating companies.

Rotary converters located at substations spaced along the system (Fig. 1) provided 440 V DC supplies suitable for sending trains along the route. In the station areas, the trains operated at lower speeds by using 150 V DC, derived from 440/150 V DC motor-generator sets.

In the early-1960s, the rotary converters were replaced by transformers and mercury-arc rectifiers, and the 6.6 kV feeders were replaced by London Electricity Board (LEB) 11 kV supplies, at Liverpool Street, King Edward Building, Mount Pleasant and Paddington PO Railway stations. Western District Office (WDO) has had an 11 kV supply since it was commissioned.

## TRIAL

The railway has recently been re-equipped with new rolling stock at a total cost of some £1.6M.

In 1979, consideration was given to the replacement of the transformers and mercury-arc rectifiers. The following factors were considered:

- (a) the need to supplement the investment in new rolling stock;
- (b) the mercury-arc glass bulbs were obsolete and replacements (other than limited spares held) were very expensive and later impossible to obtain;
- (c) the internal condition of the transformers was not known with certainty and examination would have been difficult and expensive; also, it would have incurred a degree of operational risk, because transformers under examination would not have been available for service; and
- (d) energy savings were possible by the elimination of the arc volt drop and cooling fans.

Accordingly, it was decided to obtain a new solid-state (silicon) rectifier and, by using supplies from an existing transformer, to operate the unit on a trial basis. The rectifier was connected in a 3-phase bridge configuration and had protection circuits for limiting transient surges (see Fig. 2). The equipment was obtained, installed and put into service at the King Edward Building PO Railway Station in July 1980, and used specially fabricated frames constructed to fit inside an existing cubicle.

† London Postal Region, Post Office

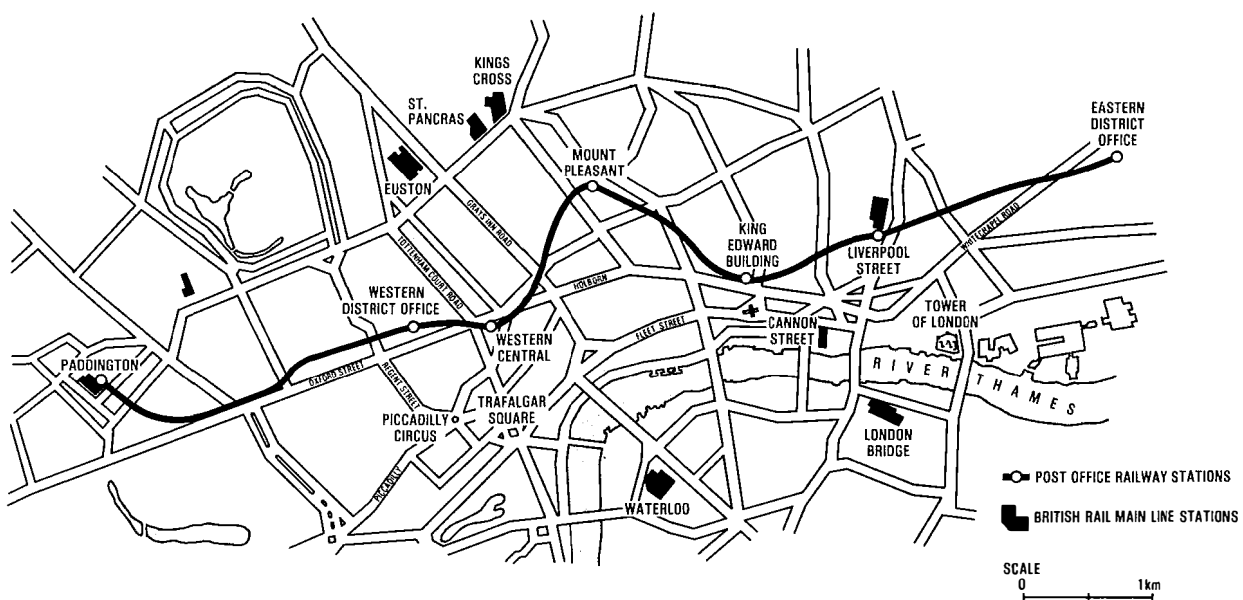
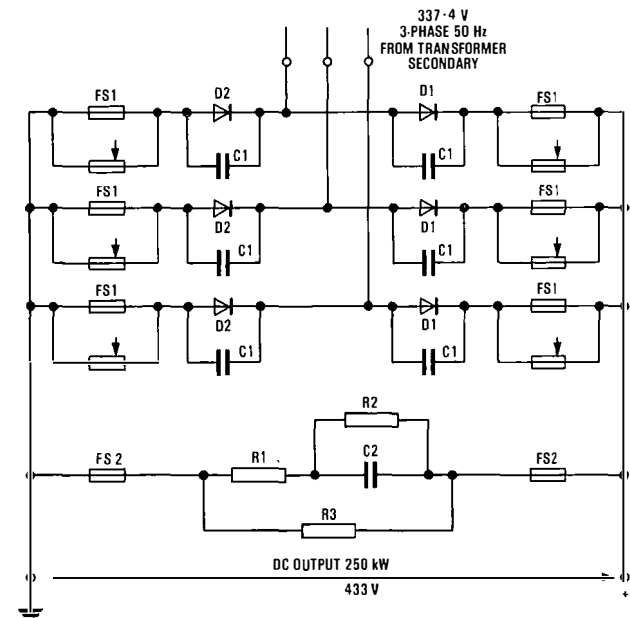

FIG. 1—Post Office Railway





- C1: Hole storage capacitors 0.47  $\mu$ F
- C2: DC surge capacitor 22  $\mu$ F
- D1, D2: Diodes
- FS1: Diode fuse and indicator fuse
- FS2: DC surge fuse
- R1: DC surge resistor 4 in parallel each 8  $\Omega$
- R2: Discharge resistor 1 M $\Omega$
- R3: Light load resistor 2.5 k $\Omega$

FIG. 2—Rectifier bridge configuration

### TRACTION REQUIREMENTS

Fig. 3 shows a single rolling-stock unit comprising 2 motorised bogies, car body and associated mail containers (units may be run singly or in pairs coupled together).

Fig. 4 shows a block diagram for the unit. The circuit is simple in operation. Current passes from the collector shoe through the brake solenoid, the motor field, and the motor armature, which are all in a series circuit.

Heavy-duty resistances are permanently in series with the collector shoes and the motors. These resistors provide an even distribution of current to the motors, and limit current surges on starting or on occasions when dissimilar voltages are bridged by the trains (this can occur at the change-over of the 440 V and 150 V conductor rails). These surges, although limited by resistances, are demanding on the rectifier equipment.

The trial of the new silicon rectifier unit was satisfactory; the unit proved to be reliable in operation. Accordingly, it was decided to proceed with the replacement of all of the mercury-arc units by solid-state equipment, the opportunity also being taken at this time to replace the transformers.

### CONTRACT

A contract was placed with GEC Rectifiers (now GEC Transmission and Distribution Projects) in January 1982 for the provision and installation of the 8 units at the locations shown in Table 1.

GEC Rectifiers had overall responsibility for the removal

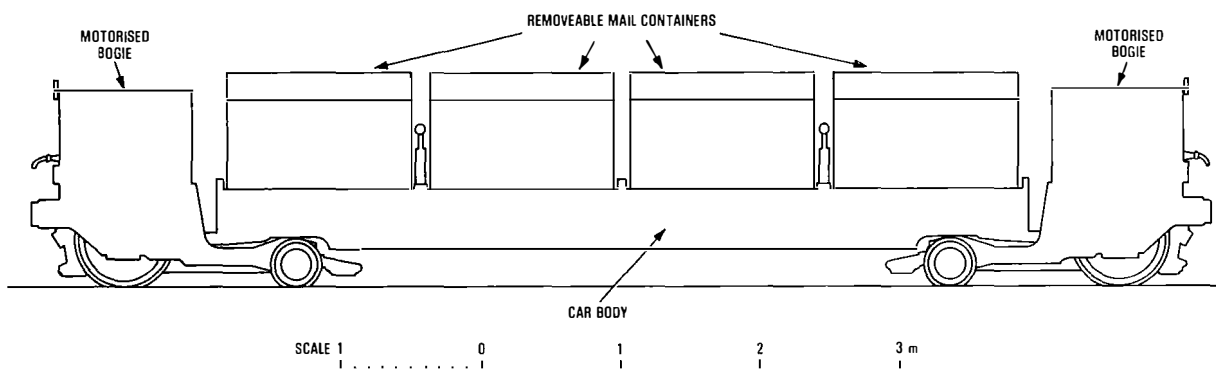

FIG. 3—Rolling stock layout

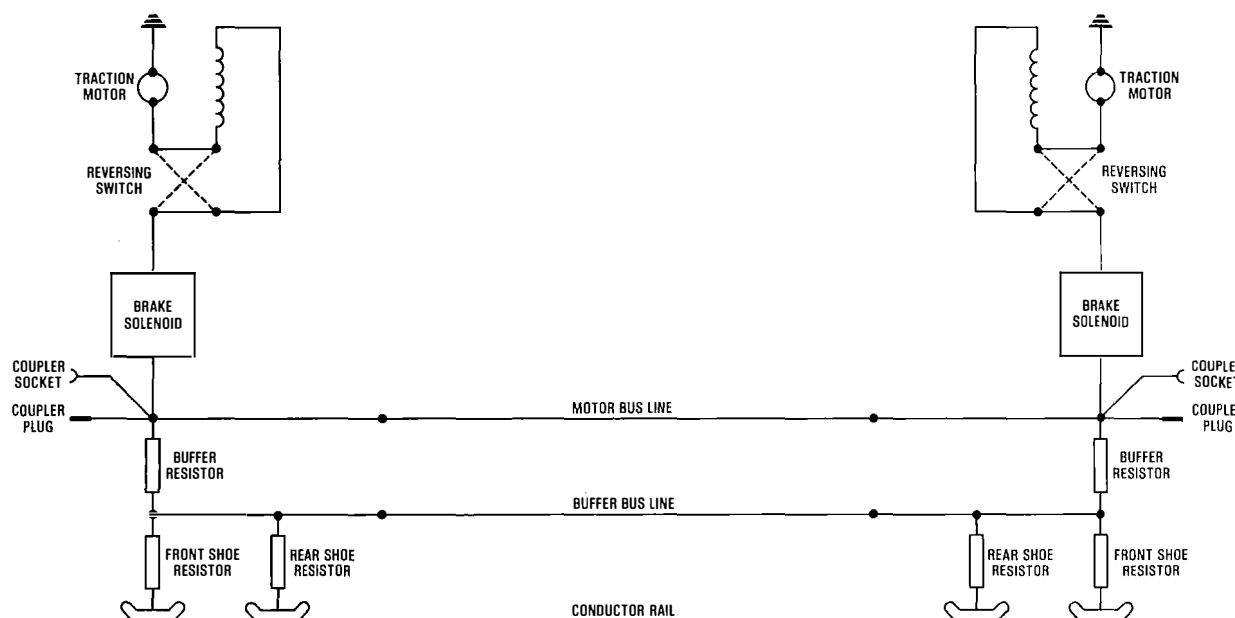

FIG. 4—Rolling stock circuit diagram

**TABLE 1**  
**Location of Transformer/Rectifier Units**

Location	Number of Units
Mount Pleasant MLO	2
Paddington MLO	1
King Edward Building MLO	1
Liverpool Street Station	2
Western District Office	2

MLO: Mechanised letter office

and disposal of the old Pyroclor-filled transformers and the mercury-arc rectifiers, the supply and erection of the new transformer/rectifier equipment, and the re-cabling and re-commissioning of the system.

### Installation

The units are installed under the station platforms in engineering equipment areas. Fig. 5 shows a typical installation. The units are totally enclosed and special precautions have been taken to ensure safe access by using Castell key locking arrangements and by effectively screening all live conductors. The transformer units are housed in new enclosures, but the silicon rectifiers have been installed in the existing cubicles made spare by the recovery of the mercury-arc rectifiers.

### Transformers

The new transformer units were manufactured by the Midland Transformer Company (as subcontractor to GEC), and were installed by GEC (see Fig. 6).

The transformers are the enclosed, ventilated indoor type to BS 4417:1969 Class C. They have a primary voltage of  $11\,000\text{ V} \pm 2.5\%$  and  $5\%$  3-phase by tap changing, and a secondary voltage of  $337.4\text{ V}$  3-phase  $275\text{ kV A}$ . This secondary RMS voltage, when multiplied by the rectifying factor of 1.35, less losses, produces the required DC output. The transformers also have a tertiary winding, which has an output of  $415\text{ V}$  3-phase  $44\text{ kV A}$ , and is used for supplying the separate transformers and rectifiers for the  $150\text{ V}$  DC supply, of which there are a further 8 units. (These can

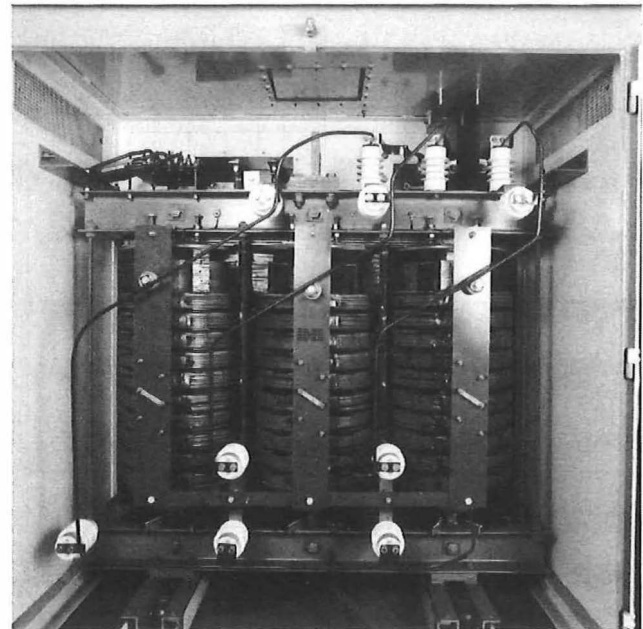

FIG. 6—Interior of transformer cabinet

also be supplied directly from local  $415\text{ V}$  3-phase AC main.)

The primary windings are delta connected, and the secondary and tertiary windings are star connected. The transformers are cooled by natural air flow.

### Rectifiers

The rectifier units were manufactured by GEC Rectifiers, and all installation work was carried out by GEC Machines on behalf of GEC Rectifiers. The large rectifiers have a rated output of  $250\text{ kW}$  per unit continuous at  $440\text{ V}$ , giving a current of  $577\text{ A}$  nominal. The small rectifiers have a rated output of  $30\text{ kW}$  per unit continuous at  $150\text{ V}$  under the same conditions, giving a current of  $200\text{ A}$  nominal.

The new silicon rectifier unit is shown in Fig. 7.

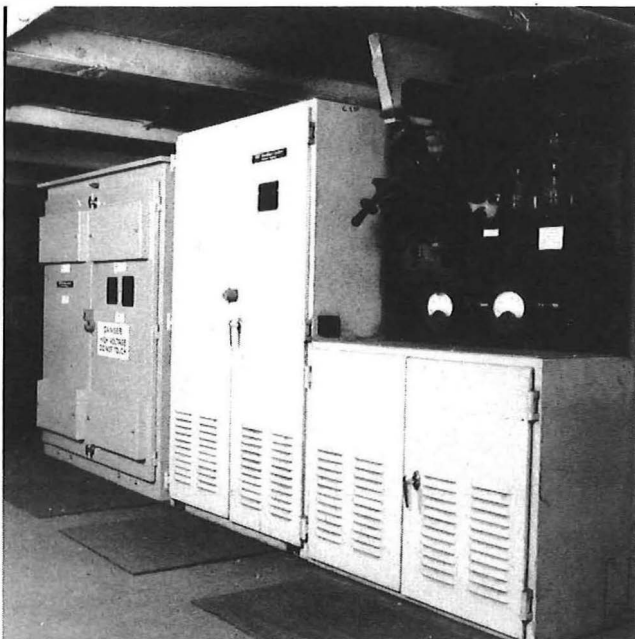

Note: The new transformer cabinet is on the left. The existing rectifier cubicle used to house the new silicon rectifiers is in the centre, and to the right is the DC switchgear

FIG. 5—Typical transformer/rectifier installation

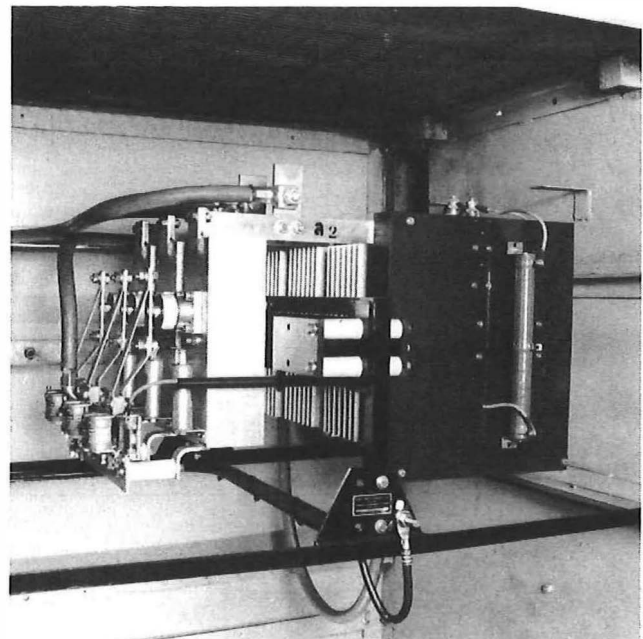

FIG. 7—New silicon rectifier unit

## DISPOSAL OF OBSOLETE EQUIPMENT

Because the chemicals used in the insulants of the old transformers were toxic and non bio-degradable when released from their sealed environment, specialist subcontractors were employed to remove the old equipment. The chemicals were removed under controlled conditions and subsequently burnt.

## POWER CONSUMPTION

The increased efficiency of the new plant has reduced the power consumption of the system by about 0.2 kW h per car mile (about 18 500 kW h per month).

## CONCLUSION

The satisfactory completion of this contract, together with that for the new rolling stock, should ensure reliable service from the PO Railway for the next 30 years at least, and means that the PO continues to gain from the prudent investment made some 70 years ago, when the tunnels were excavated.

## ACKNOWLEDGEMENT

The authors are grateful to Mr. L. W. Oatey, Controller Engineering, London Postal Region for his permission to publish this paper.

---

# The Tenth International Teletraffic Congress, Montreal, 1983

N. W. MACFADYEN, M.A., PH.D.†

The Tenth International Teletraffic Congress (ITC) was held in Montreal from 8–15 June 1983, under the sponsorship of the Canadian telecommunications community and with the co-operation and assistance of the Canadian Government and the city of Montreal.

The ITC, which has no journal or continuing existence between triennial congresses, except for a small permanent International Advisory Council, is a forum for the discussion and publication of developments in all branches of teletraffic theory. The continuing increase in the size of the Congress indicates the importance and general interest of this field of study. On this occasion it was attended by some 310 delegates from 27 countries, ranging from the USSR to the USA, Australia to Finland, Brazil to Hong Kong. Sixteen delegates, drawn approximately evenly from the telecommunications manufacturing industry, British Telecom and the universities, attended from the UK, and contributed, in whole or in part, 8 papers.

The large quantity of material presented at the Congress meant that the 150 technical papers\* were divided almost equally between those presented by their authors, who were allocated some 15 min each, and those summarised by a discussion leader in each session.

No consistent distinction can be drawn between read and non-read papers, either on grounds of content, or, as the number of questions indicated, on the degree of interest or topicality. Once again, parallel sessions were introduced for one afternoon, offering a choice between mathematical topics in queueing theory, and the analysis of networks with overflow and alternative routing. The more technical aspects of the former were also discussed in an informal supplementary session, which attracted much interest.

It is impossible to summarise in a few words the entire range of material covered, and so this article mentions only those areas of greatest interest or those in which significant trends seemed to be present. Certainly the most important of these was the attention given to overflow traffic and

networks with alternative routing, and to the savings that may be realisable with dynamic routing or non-hierarchical networks. Much theoretical material was presented here, which complemented the more practical discussions of other conferences. The large number of papers on general questions of dimensioning policy, overall grade of service, and realistic traffic and subscriber behaviour testified to the continuing active interest in quality of service; but the great variety of criteria adopted by different countries showed not only the lack of unanimity as to the best approach to adopt, but also perhaps the remarkable robustness in practice of provisioning levels and costs.

Much interest was shown in new systems, and papers on the theoretical or experimental aspects of these attracted many questions and informal discussion. Unfortunately, although a wide spread of systems was represented, the total number of contributions was rather small. This probably reflects the increasing overlap of this field with the closely related field of computer-performance evaluation, as well as the commercial sensitivity that is inherent in all such new developments as local area networks, mobile radio or integrated voice/data services.

The more purely theoretical aspects of teletraffic theory were well represented by the discussions on queueing theory and its applications. The emphasis in this field has now moved firmly to delay systems and methods of approximating single queues or networks which are reasonably widely applicable. Questions of correlations and interaction between queues were particularly welcome and some new technical developments in this area were received with great interest.

Several areas of traffic theory in which active interest was shown in the past are now of diminishing relevance, and attracted fewer papers. Among these, in particular, was the theoretical study of link systems, where the final flowering of theory has been rendered largely irrelevant because of the development of new systems and new engineering. It is a sign of the vigour and good health of teletraffic theory, as well as its continuing relevance, that its development should so closely track that of the systems of importance today and in the future.

The Eleventh International Teletraffic Congress will, by invitation of the Japanese authorities, be held in Kyoto in 1986.

---

† Systems Evolution and Standards Department, British Telecom Development and Procurement

\* The *Proceedings* of the ITCs are held by the Science Reference Library, 25 Southampton Buildings, Chancery Lane, London WC2A 1AW

# Book Reviews

*Basic Electronic Switching for Telephone Systems (Including the latest advances in digital technology)*. Second Edition. David Talley. Hayden Book Company, Inc. 312 pp. 161 ills. £9.60.

This book adopts a tutorial approach to a description of central-office switching systems in the USA, and has questions at the end of each chapter to test readers' understanding of the text.

The author asserts that his aim is, 'to give the engineer, technician, manager and student a strong working knowledge of electronic switching systems now in use'. His concentration on systems now to be found in Central Offices of the USA should be no surprise to readers of the book. However, the first major disappointment is that the discussion of digital systems, promised by the subtitle, occupies less than 10% of the book. A further surprise is that there is no bibliography; pointers to the principal technical papers describing each system would have been most useful.

The first chapter gives some background to the structure of the North American network, and to the obsolete systems still to be found in it. The second chapter is concerned with the basic elements of switching systems, and how these have been incorporated into processor-controlled systems such as ESS1 and ESS1A. There is also a brief statement that such systems offer automatic load-control features, but no explanation of the importance of these to a common-control switch.

The chapters which follow give a brief introduction to basic digital logic and how this can be transferred to a computer control; describe the hardware of the ESS1 processor and its evolution to the 1A processor; and outline the various memory systems used with them—predominantly dealing with the magnetic-core type.

Chapter 6 gives useful details of the organisation of the call processing function, and of the essential timing functions of the executive program. This is followed by a chapter on the switching matrix, the master control panel and the power system. A further chapter describes most of the remaining electronic non-digital switching systems to be found in the USA and Canada.

The final chapter, after a description of the principles of digital transmission and of time and space switching, in a total of 38 pages, manages to mention No. 4 ESS, network synchronisation, the mass-announcement system, common-channel signalling, subscriber-line interfacing, the GTE No. 3 EAX, and, finally, in the last few pages, a host of other important systems such as the ITT System 1240.

This last chapter contains subject matter enough for a whole book, and one feels that few of its intended readers will gain much insight into modern trends and problems from such a rushed treatment.

For UK readers this book is likely to be of little interest, except perhaps as an introduction to a study of historical papers from the 1970s, for which the explanations in this book of such items as the *twistor store* and the *ferrod* could be of some help.

M. R. MILLER

*Local Telecommunications*. Edited by J. M. Griffiths. Peter Peregrinus. x+265 pp. 89 ills. £24.50.

This ought to be a useful book. It deals with public local networks from customer equipment, through local distribution, up to the periphery of the local telephone exchange or other local nodes. It begins by recognising that this part of the overall network has hitherto received less than its due share of attention, mainly because its function was simple and because there seemed better things to do elsewhere. With the advent of a multitude of technological and commercial opportunities bursting on the local network, the book sets out to describe comprehensively the existing network in the UK, and some of the possible developments in the future. It describes the way in which the network is organised, the manner in which transmission and other factors affect it, the impact of broadband techniques and glass-fibre penetration. The latter are of special interest, since (at the time of writing) the first round of franchises for UK cable television are just being awarded.

To complete a comprehensive coverage, the book includes chapters on customer equipment, human factors, and marketing—aspects of increased importance for anyone seeking to make the most of the possibilities now offered. It also contains a short description of overseas methods, and even a chapter on national Telex and packet-switching networks: scarcely 'local', but a useful inclusion none the less.

The strength of the book derives from the fact that its contributors are experts in their respective fields; however, this is also its weakness. It comprises papers which the authors presented at an Institution of Electrical Engineers' summer school. As a consequence, since the authors did not originally know that their contributions would be reproduced and published as a book, the level of attack varies and the material lacks a certain cohesion. There is some odd sequencing; for instance, chapter 2 gets quickly into the complexities of send and receive reference equivalents, while chapter 5 goes back to string and cocoa-tin transmission, and leads on gently from there. No doubt the verbal presentations were able to smooth all this out, but in print the result is rather less than professional presentation. The fault is not with the authors or the editor, but with those who took the original decision to produce the book in this way.

That said, it is a useful introduction to the subject, especially for anyone coming into this field for the first time and interested in its now enlarged potential for development.

J. TIPLER

*Telecommunications: A Technology For Change*. Eryl Davies. Her Majesty's Stationery Office. 60 pp. 116 ills. £2.95.

This booklet is a recent addition to the series prepared by the London Science Museum to illustrate their exhibits and to recount the history behind them. In this case, it is complementary to the Museum's imposing new telecommunications gallery that supersedes the earlier, less satisfactory one.

The booklet is well produced and illustrated, and many of the illustrations will be familiar to British Telecom (BT) engineers. It details developments from the earliest experiments in sending signals along wires to present day optical-fibre transmission; it also outlines the parallel developments in switching signals through exchanges, culminating in System X exchange principles.

Included in the booklet is a useful date chart which indicates from 1800 onwards the years in which the principal developments were introduced. The linear scale of the chart demonstrates the accelerating pace of change. It is, therefore, perhaps inevitable that early history is covered in more detail than more recent history. For example, there are several illustrations of overhead wires on poles, but no photographs or diagrams showing the different types of cables—distribution, coaxial, submarine, or optical fibre—which have been developed. This seems to indicate that there is scope for an expanded booklet, or a second booklet, providing a fuller treatment of more recent developments, say from the availability of the transistor onwards, which might be of even more general interest and usefulness.

There are some misconceptions. It is suggested, for example, that the use of amplifiers on cables obviates the need for loading coils.

There is a glossary of terms, and here there are some weaknesses, such as in the definitions of multiplexing. The difference between trunk and junction circuits is incorrectly defined as a distance of 24 km being the lower and upper length limit, respectively, of these circuits. Several books are listed for further reading.

This booklet should be a useful and interesting history of telecommunications for the layman and for science teachers, but telecommunication engineers can refer to the Institution of Post Office Electrical Engineers' 50th and 75th Anniversary issues of this *Journal*, published in 1956 and 1981, for more detailed, and satisfactory, sources of the historical progress of telecommunications.

K. E. PARISH

# Processor-Controlled Systems for the Testing of Customers' Lines

D. V. THORPE, T.ENG.(C.E.I.), A.M.I.E.R.E.†

UDC 621.395.743.001.42 : 681.3

*As part of an agreed strategy to improve and modernise British Telecom's (BT's) repair service, processor-controlled equipment is being introduced for testing customers' lines. In seeking solutions to problems experienced in present day Repair Service Controls (RSCs), test-system designers have evolved differing sets of design criteria. To assist in the understanding of these designs, this article details the parameters of a local line, the fault conditions that may be encountered and the electrical terminations presented by customer's apparatus. Three categories of system architecture are described and information is given on the measurement techniques employed by the test units found in each type of system. Examples of all 3 types of test system are being deployed within the BT network and the operational performance of each is being evaluated. The article concludes by reviewing the present state of the art, and by exploring how ongoing developments may further enhance the operational effectiveness of these systems.*

## INTRODUCTION

Since the birth of the telephone system, line testing has been manually undertaken from a test desk. The results obtained are dependent on the interpretation given to various kicks and deflections of the test meter. Only when the automation of this process is attempted is it fully realised how adept the human brain is at analysing time-related readings. Nevertheless, there is scope for using the power of a computer to improve on the accuracy and consistency of these measurement methods, with the human interface being provided by visual display terminals at the Repair Service Control (RSC). Before these techniques are discussed, it is necessary to understand the present-day problems of an RSC: for the prime objective of a modern test system is to alleviate these problems, and it is the emphasis given to the various problems by designers that has resulted in differing systems.

RSCs today handle fault reports on a geographical basis. Where practical, test junctions are provided to all exchanges within the test area. This, in itself, is a compromise, as the accuracy of a test declines as the length of the test junction increases.

In some instances, control of the test access and meaningful measurements are not possible over a test junction, because of the distance involved or the non-availability of a metallic circuit. Staff then have to be dispatched to the distant exchange to perform these functions.

An unrelated, but possibly more significant, problem for many RSCs concerns the efficient handling of the large quantity of record cards. The introduction of a computerised database is an attractive solution to this problem, but is incompatible with line measurements made from a test desk. To convert subjective assessments of the movement of a meter into a form that can be typed into a database is both difficult and time consuming.

The third problem for an RSC lays in accurately dispatching the correctly skilled faultsman to the location of the fault. Electrical location of a fault from a test desk is impractical; thus, experience is necessary to decide who should repair the fault. A leakage fault to battery is often given to a cable jointer, who is likely to work outwards from the exchange to locate the fault. Other fault conditions

invariably result in the dispatch of the customer-apparatus faultsman, who may well start his location from the customer's premises. With this process it is not uncommon for a fault to be double handled by field staff, and result in an increase in the out-of-service time.

## DESIGN OBJECTIVES

With such diverse operational problems being encountered by the repair service, no manufacturer has attempted to design a test system to meet all needs. Test systems can be considered to fall into 3 categories, with each having the prime design objective of solving one of the described operational problems. The developed systems being offered are based on markedly different architectures and use fundamentally different measuring techniques to meet these aims.

### Design Criteria

The reasons for these differences can be found by considering the design criteria needed to solve the separate operational problems.

#### System Avoiding Manual Line Testing at Remote Exchanges

The long length of test junctions that prohibit testing are mainly encountered in rural areas. For this reason, many small rural exchanges have, at present, no test facility available from their RSC. To overcome this problem, test units must be designed for deployment in remote exchanges and be controlled from the centre via a data link. This link may be provided over the public switched telephone network (PSTN) or, to give more security, private circuits may be used (see Fig. 1). As the test units may often be installed in small exchanges, their cost must be kept to a minimum if the total system cost per line is to be affordable. This need for a low-cost test unit precludes the use of complex measurement techniques, and thus compromises the accuracy of measurement and leads to long measurement times running into seconds for each parametric reading. Additional facilities, such as a man-machine interface for use by visiting faultsman, are often precluded by the need for an economical test unit.

Many rural RSCs cover areas with a low telephone density, warranting only a few test positions in the RSC. A test

† Local Exchange Services, British Telecom Local Communications Services

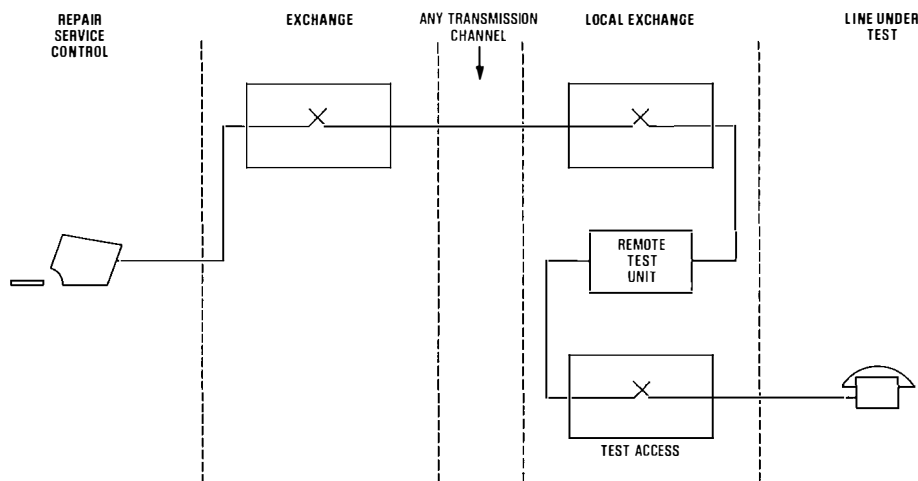

FIG. 1—Remote testing system with dial-up over the PSTN

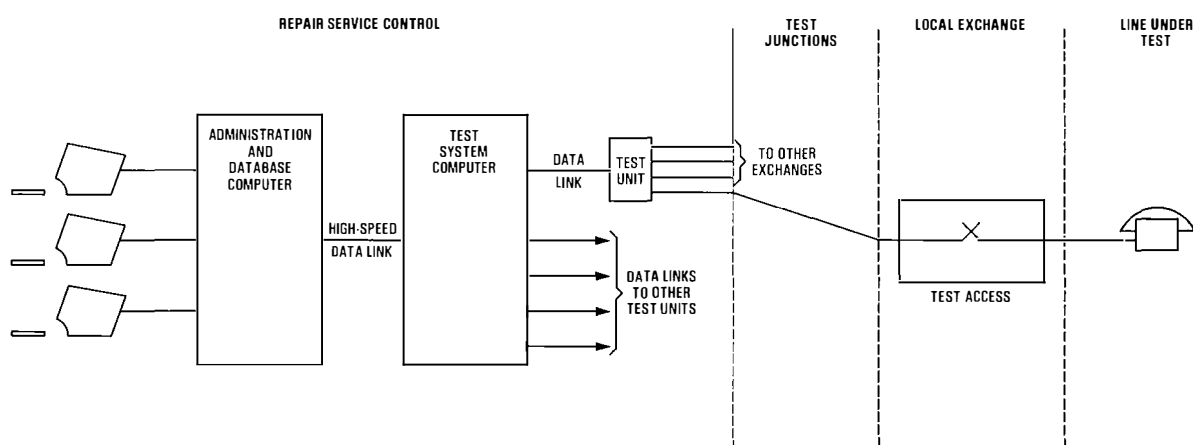

FIG. 2—Test system with integrated database

system suitable for this environment must therefore be modular in the design of its control equipment, if it is to be cost effective. Self-contained intelligent terminals having a microprocessor that also controls the remote test units is an attractive solution.

The main limitation of this distributed-processing architecture is that it lacks a central computer to act as a focal point for interconnection to a database or other computer systems. The expense of many intelligent terminals with duplicate processing capability is also unattractive at larger RSCs. The end result of attempting to cost reduce this terminal is often a design that has little scope for enhancement.

#### Test System Suitable for Integration with a Database

Several manufacturers have developed test systems that can be integrated with a database. With these test systems, both testing and database functions can be controlled from the same terminal, with information from both sources being integrated on the display. Attractive features such as interworking between RSCs for a 24-hour repair service and interconnection to other computer systems can readily be achieved with this architecture.

The cost of the central computers makes this architecture unattractively expensive to deploy in small RSCs. The larger RSCs invariably cover the less rural areas where testing over junctions is more practical. Thus, it is most economic for test units to be centrally situated and to be switched over

a network of test junctions to the required exchange for test purposes (see Fig. 2). The testing techniques used must be sophisticated if results obtained over test junctions are to be comparable with those obtainable from the local exchange.

Exchanges to which there are no spare metallic pairs available require a dedicated test unit, and this can be expensive; but, in suitable areas where metallic access is widely available, the number of test units deployed will be considerably less than the number of exchanges served, which will make the system economic. It is not practical, with present technology, to locate electrically a fault when testing over junctions, as the local line is often much shorter than, and at the far end of, the test junction. The design of the system does not, therefore, cater for this facility.

#### Test System That Can Locate Faults

If a system is to measure accurately and locate faults, the test units are best located in each exchange, so that any degradation in measurements introduced by test junctions is avoided (see Fig. 3). The necessary advanced-measurement technology to obtain the required accuracy to locate a fault makes such units expensive to deploy in small exchanges; thus, the system is better suited to an urban area. With the present state of the art, only a small proportion of faults can be located without field staff being involved, but, once a faultman has provided a short circuit at the far side of the fault, bridge measurement techniques can be used to provide a location. This indicates that a remote loop-back facility,

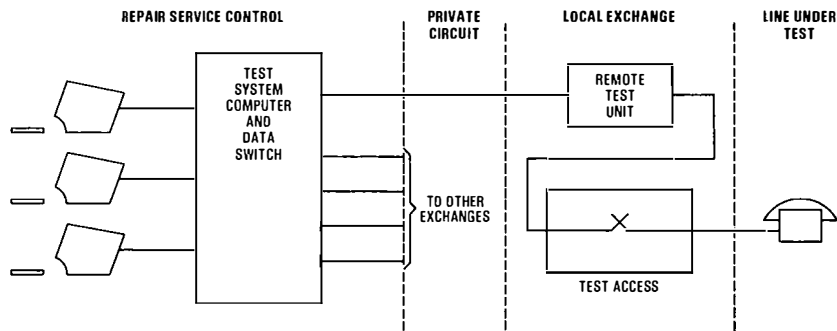

FIG. 3—Test system designed to locate faults

as now provided on private circuits, would be of use on local lines.

To handle the rapid measurement data produced by the advanced test units, such fault-location systems usually use a purpose-built real-time processor at the RSC, and it is unlikely the database will use the same type of computer. Interconnecting dissimilar machines may pose problems before a fully integrated system is produced, but sufficient processing power is usually available in this type of system for such enhancements.

A test system of this type is the most costly to deploy, but it can produce the greatest operational benefits and savings by reducing the number of faults that are double handled. The time to clear faults is also likely to be reduced as the fault locations are provided by the test system. The advanced testing techniques for fault location also provide very fast testing of good lines, and make it possible for the system to routine test all lines in one night. The results of these routines can then be processed and guidance given for preventive maintenance purposes.

### LINE CONDITIONS AND TERMINATIONS TO BE MEASURED

Before the measuring techniques used in meeting the design objectives of the various test systems are discussed, illustrations of the line parameters, fault conditions and terminations commonly found in BT's network are given to assist the reader to understand these techniques. Fig. 4 shows the line capacitances diagrammatically. On local cables there is a fairly constant relationship between the 3 capacitance configurations, with the capacitances of each wire to earth being fairly equal and the capacitance across the pair being less than half of that of one wire to earth.

There are 5 possible leakage paths, which are illustrated in Fig. 5. Each wire may have a leakage fault to battery or to earth, and there may be a shunt leakage across the pair. All telephone lines have leakage paths, but service is not significantly affected until the impedance of such a leakage

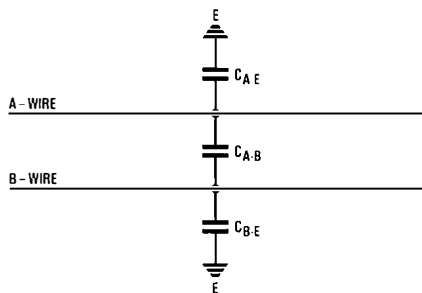

FIG. 4—Line capacitances

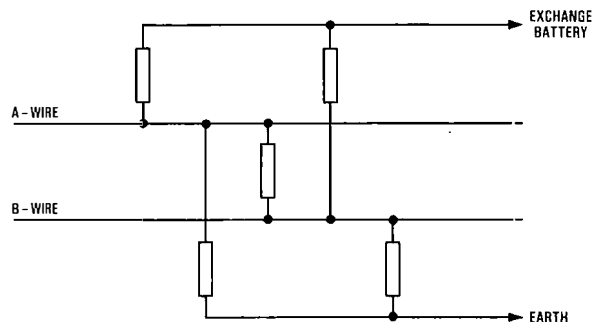

FIG. 5—Possible line leakage paths

fault is below 50 kΩ. An increasingly common fault, not illustrated, is additional series resistance in the line, possibly caused by a corroded joint. This type of fault appears to be more prevalent in BT's network than it is in other administration's networks, and it is difficult to detect with the use of DC measuring techniques.

The range of terminal equipment on offer to BT's customers is growing quickly and bringing an increasing number of terminating characteristics that are encountered by test systems. The most commonly found termination at present is that of a single telephone on a direct exchange line (DEL). The use of thermistors in shared-service telephones, and the telephone-unplugged condition, are found only in the UK; some test systems find these conditions difficult to measure. These common terminations are illustrated in Fig. 6.

### MEASURING TECHNIQUES AND CIRCUIT DESCRIPTIONS

Now that the systems design criteria and architectures have been detailed, descriptions of commonly used measurement techniques employed by each of the 3 categories of test system can be given.

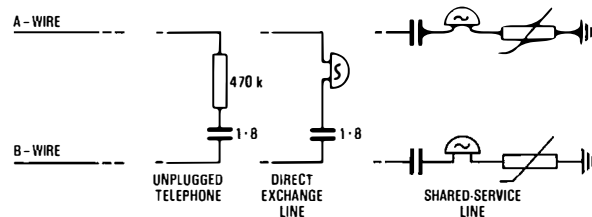

FIG. 6—Commonly found terminations

## Measuring Techniques for a Remote Test Unit

As explained previously, a prime objective in this design is to produce a low-cost remote test unit. This is realised by using DC measuring techniques and developing simple circuitry that can be switched to test for parameters in all configurations. The analogue voltages developed across a known source resistance are converted to digital form and processed before the results are returned over the data link to the control point (see Fig. 7).

To measure for earth leakage on the A-wire, the source voltage is switched to 50 V (relay S) and, after allowing time for the line to be charged, any voltage developed across the source resistance must be due to a leakage current to earth. This voltage is converted to digital form and read by the processor. The source resistance, which may be a few thousand ohms, is used by the processor in its calculations of the actual leakage value as follows:

leakage resistance =

$$\frac{50 - \text{measured voltage}}{\text{measured voltage}} \times \text{source resistance.}$$

To measure for earth leakage on the B-wire, the test is conducted on the other wire by the processor first operating relay R.

Relays A and B allow the wire not being measured to be earthed; thus any shunt leakage across the pair can be found.

For measurement of leakage-to-battery, relay S remains inoperative such that the source resistance is backed by an earth and any steady current flow must be from a battery leakage fault. By assuming the battery leakage to be at 50 V, the same calculation can be made by the processor to give the leakage resistance of the line fault.

A commonly used technique for measuring capacitance is the DC ballistic method. For this, the line is first charged up to a known voltage, possibly 50 V, by operating relay S, and then discharged into a known reference capacitor by operating relay C. After a time, both line and reference capacitor will settle to the same voltage because of the original charge on the line. The voltage developed across the reference capacitor is again converted to digital form and the processor calculates the line capacitance as follows:

line capacitance =

$$\frac{\text{measured voltage}}{50 - \text{measured voltage}} \times \text{reference capacitance.}$$

A disadvantage of this DC capacitance measurement technique is that, during the settling time, any line leakage can change the total charged current; under these circum-

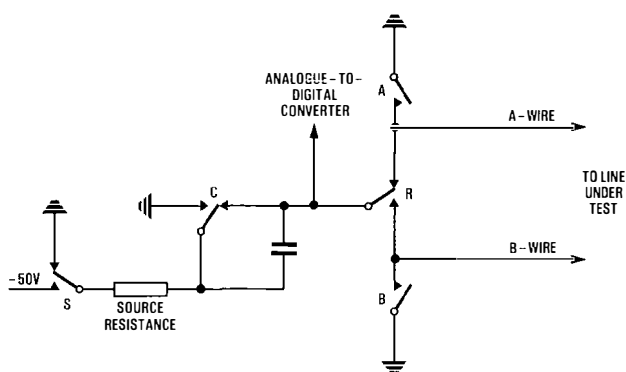

Note: Relay designations for reference purposes only

FIG. 7—Block diagram of remote testing unit

stances, the capacitance reading will be in error. Series resistance in the line extends this settling period and makes good measurements difficult. Thus, this technique tends not to give accurate capacitance readings on shared-service lines, which have thermistors, or when the telephone is unplugged and the 470 kΩ resistor is in circuit.

A test system designed on this basis results in an economic product and provides testing in exchanges that would otherwise require, because of their remoteness from an RSC, an engineer to visit them.

## Measuring Techniques for Testing over Junctions

Many such systems started with a test unit similar in design to that previously described for remote line testing. The measurement results, however, now include the test junction parameters, but it would not appear difficult for the central computer to subtract the relevant junction parameters and display only the line readings. Unfortunately, this process gives grossly inaccurate results because of a basic limitation of the measurement techniques described previously, in that they produce complex readings of all parallel paths for each parameter. This is best understood by referring back to Fig. 4, which illustrates the line capacitances. A measurement of capacitance from the A-wire to earth in fact gives the complex reading of this actual capacitance in parallel with the capacitance across the pair in series with the other wire's capacitance to earth:

$$\text{measured capacitance A-E} = C_{A-E} + \frac{C_{A-B} \times C_{B-E}}{C_{A-B} + C_{B-E}}$$

In practice, a standard DEL telephone connected on the end of the line places the 1.8 μF bell capacitor across the line which, in the ballistic test, would give a complex reading of capacitance in the wire-to-earth configuration of nearly double the true value. True measurement readings must be taken to permit the processor to remove test junction parameters.

The technique of dual measurement circuitry, one for each wire, is used to achieve this. Similar DC tests are used to measure leakages, but in this case, the same test voltages are applied simultaneously to both wires; thus, no current flows across the pair even though a parallel path may exist. This produces true leakage readings on both wires obtained at the same time. The circuit again provides for measurements across the pair to be subsequently taken and the true value computed as the other readings are, by then, known.

To understand this better, consider the measurement for leakage to battery. For this the source resistors are earth backed as illustrated in Fig. 8. Compared with most leakage faults, the value of the source resistors is low; thus, both wires being measured are held close to the earth potential.

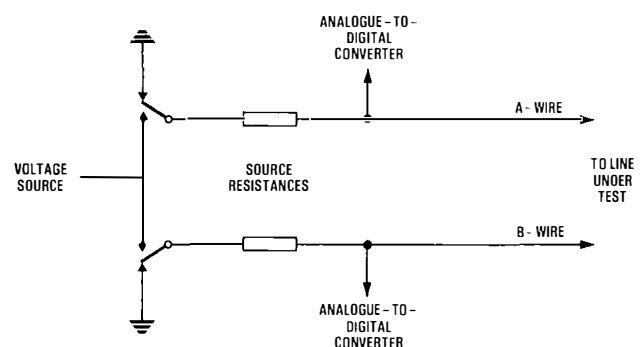

FIG. 8—Block diagram of a unit suitable for testing over junctions



Therefore, any voltages developed across either of the source resistors are caused by a leakage to battery on the respective wire, and any very small current flow across the pair can be ignored. The principle of not developing a potential difference across the pair can also form the basis of a dual test for impedances to earth using an alternating voltage source, the objective being to calculate capacitance readings.

The design criteria to test over junctions detracts from the effectiveness of AC testing techniques. This is because, over the telephony frequency range, the characteristic impedance of BT's junction cables masks the impedances of a local line and thus reduces the ability of AC techniques to measure accurately capacitance over test junctions. The DC ballistic capacitance test cannot easily be used in a dual mode as there are problems in keeping the settlement times the same in both wires if the line has any leakage to unbalance it. A more commonly used technique is to ramp the source voltages together as measurements of current flows are being taken (see Fig. 9). Once again, the principal aim is to keep the same voltage on each wire to prevent any charging current being taken by the capacitance across the pair.

As with all DC measurement techniques, the voltage changes applied to line must be regulated to avoid the customer's bell being tinkled; thus, series resistance, additional to that of the line and the test junction, may be inserted by the test unit when capacitance tests are conducted. The line is charged by increasing the test voltage at a controlled rate. At first, the charging current is limited by the series resistance and builds up as the test voltage is increased. This current build-up continues until the line capacitance is being charged at a rate that produces a voltage build-up on the line, ramping at the same rate as the applied test voltage. If such a constant current state is not reached, this is due to leakages on the line. The complexity of this technique is in the processor analysis to remove the effects of any line leakages. Design engineers tend to use algorithms for this, rather than a single mathematical equation.

The accuracy in measurement of customers' lines obtained by using these techniques is comparable with that of the remote test-unit design, but, in this case, the testing is conducted over test junctions with the effects of the junction removed by the computer. Dual-measurement circuitry considerably increases the component count with a corresponding increase in the cost of the test unit. This cost has to be set against each unit's ability to serve more than one exchange. Two measurements taken together more than halves the testing time, which is significant both in deciding how many test units to deploy and in the operational efficiency of the staff using the system.

### Techniques to Measure and Locate Faults

To obtain the most accurate location of a fault, a test unit

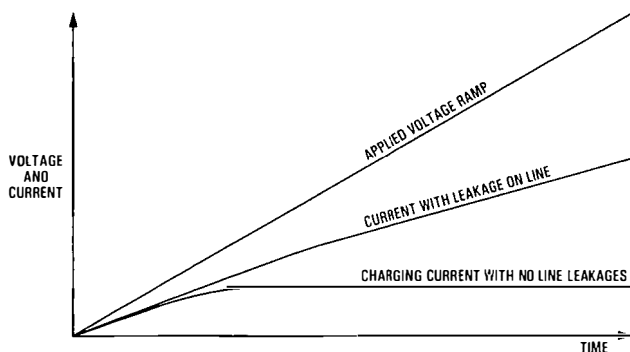

FIG. 9—Capacitance measurement techniques—voltage ramp/ currents graphs

must be deployed in each exchange. If test junctions are not encountered, the DC techniques to measure leakage can be supplemented with AC techniques to measure for capacitance and inductance. When these techniques are being discussed, it is correct to describe the parameters being measured as *admittance, susceptance, conductance and leakage*, for these are the values needed by the central processor to allow the location of a fault to be computed.

The dual-headed technique described earlier in this article is now taken a stage further. DC amplifiers with very low output impedances, typically less than 1 Ω, are used to force the same source voltage onto both wires. Thus, the chance of error due to any current flow across the pair is virtually eliminated and very accurate true measurements are possible. To provide a means of reading the current flowing to line, without introducing additional series resistance, the amplifier also produces a separate output voltage that is proportional to the current being fed to line. This is presented to an analogue-to-digital converter and the output is read by the test unit's processor. (See Fig. 10.)

By using a source potential of -50 V, the presence of any leakage to earth can easily be computed from:

$$\text{leakage resistance} = \frac{50 \text{ V}}{\text{current feed}}$$

For an accurate measurement of leakage-to-battery, the battery contact voltage must first be measured. Usually, very high impedance devices are used for voltage measurements, but such circuits are very prone to picking up interference, both at radio frequencies and from the mains supply, when employed on local lines. Thus, to measure the voltage of a battery contact, the amplifiers are earth sourced and their output impedance increased to a few hundred kilohms. A second set of measurements, to establish the current flow to the leakage, is undertaken with the amplifier in its low-impedance mode and earth backed. This produces 2 simultaneous equations that can be solved by the processor to give an accurate measurement of leakage to battery:

$$\begin{aligned} \text{measured current flow from high impedance source} \\ = \frac{\text{battery contact voltage}}{\text{leakage resistance} + \text{source impedance}}, \text{ and} \end{aligned}$$

$$\begin{aligned} \text{measured current flow from low impedance} \\ = \frac{\text{battery contact voltage}}{\text{leakage resistance}}. \end{aligned}$$

To measure the admittance parameter of the line under test, an alternating voltage is used as the input source to both amplifiers. Modern solid-state driver circuitry can

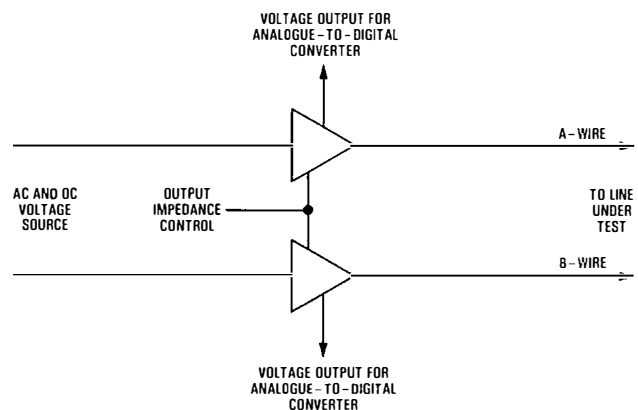

FIG. 10—Block diagram of a test unit designed to locate faults

produce both DC and AC source supplies under the control of the microprocessor, and thus avoid the need for any relay switching. The amplifiers are in their low-impedance mode and the alternating driving voltages are kept in phase to avoid any current flow across the pair that might influence the measurements. The processor takes rapid readings, not only to establish the RMS value of the current flow, but also to deduce the phase angle between voltage and current. From this, the susceptance and conductance components of the admittance can be found. This is one of the few measurement techniques that enables the series resistance of the line to be calculated, and therefore permits the location of series resistance faults.

Accurate true measurements of this nature enable the central processor to diagnose the line conditions and, separately, determine the electrical parameters presented by the increasingly wide variety of customers' equipment. This will be of increasing importance as liberalisation spreads, but the prime objective of the system is to locate faults. For this, the dual-measurement circuitry is used in a bridge configuration. Each amplifier supplies current to a leakage fault, but the nearer the fault is to a given amplifier, the greater is the proportion of current supplied by that amplifier.

Often, it is necessary to dispatch a faultsmen to provide a loop at the distant side of the line fault for the system to operate in this mode. However, some faults can be located by using the AC measuring technique, without the need for this loop to be applied.

The advantages of using this design of system are obvious, but the cost of developing and manufacturing such advanced test units makes such systems very expensive to purchase.

## REVIEW

A single system that meets all needs would at present be prohibitively expensive to develop, and could not, therefore, be realistically priced. Available test systems fall into 3 categories, and it is noticeable that each type uses different measurement techniques to meet their objectives.

A low-cost remote-testing system produces measurement data that is compatible with its needs, but not suitable for detailed computer analysis.

A system designed to test over junctions takes true parametric measurements. These readings are suitable for computer analysis and, indeed, processing is needed to remove the effects of the test junction over which measurements are made. This type of test system is now being offered with a fully integrated database.

A test system designed to locate faults is obviously the most complex, and it produces very accurate true-measurement data. Considerable processing is incorporated to analyse this data and calculate the location of any fault. The full integration of this type of system with a database is

still under development, the task being complicated by the complexity of the data produced by the test system itself. When available, an integrated system of this type should outperform all others, as it will be based on superior testing techniques.

## OUTLOOK

The availability of high-technology components may allow the development for remote exchanges of a cost-effective test unit that possesses the true-measurement capability currently found only in the more expensive systems. A manufacturer whose system already takes true measurements would find this kind of remote unit attractive to develop, because of the experience he has gained and the software he has available. However, a manufacturer of a remote test unit of the type presently available is faced with a considerable redevelopment task to upgrade his system.

The combined test system and database designs are constantly being enhanced by additional software. The ability of the system to collate test measurement readings with the historical line records significantly improves performance in dealing with fault reports. Nightly routines of lines in cable order are also available. The next stage would appear to be the interconnection of the test system with other telecommunication computer systems, such as those for customers' orders and bills. From a management standpoint, this interworking capability is an important consideration.

Improvements in techniques to measure and locate faults are being researched, but it is difficult to forecast when significant improvements will be made. A system that accurately locates all faults at the first attempt would be of considerable operational benefit, but in the short term, it is more likely that additional features and enhanced computing power for this type of test system will be offered. For example, the addition of synthesised voice ports to the system could enable faultsmen and installers in the field to gain access to the test system without their involving staff in the centre.

## CONCLUSIONS

Customer line test systems that are currently available fall into any one of the 3 categories discussed in this article. For optimum performance, each type of system should be deployed in the environment for which it is designed. A single system that solves all the operational problems is unlikely to be developed in the short term. Of the available systems, those based on a central processing architecture offer the greatest operational benefits, especially if their test units are able to locate distance to faults. Those who deploy this type of system today also have the greatest chance that their system may be enhanced to produce additional operational savings in the future.

# The Sixth International Conference on Computer Communication: A Review

## Part 2—The Specialist Sessions

M. B. WILLIAMS, B.SC.(ENG.), C.ENG., M.I.E.E.†

UDC 681.3 : 621.39 : 061.3

*Part 1 of this 2-part article<sup>1</sup> summarised the opening and closing plenary sessions of the sixth International Conference on Computer Communication, which was held in London from 7–10 September 1982. This second part reviews the specialist sessions.*

### INTRODUCTION

Although the 172 papers on specific topics at the sixth International Conference on Computer Communication (ICCC '82) were presented in 4 parallel streams totalling 45 sessions, they can be conveniently discussed under 6 categories in a broad overview of theme and content. Further detail on individual papers and sessions will be found in the publications of the International Council for Computer Communication (ICCC)<sup>2, 3</sup>.

### PUBLIC SERVICE COMMUNICATIONS

Successive ICCC Conferences have increasingly featured evidence of the involvement of the public-service telecommunications corporations in computer communications. This involvement has been closely linked with the progress of the international bodies (CCITT\* and ISO‡) in formulating essential definitions and standards. At ICCC '82, the maturity of the topic of public-service aspects of computer communication was indicated by the need for 10 sessions to accommodate the number and range of the accepted papers. These covered both existing and planned public-service networks, as well as discussion of their operation, interconnection and management.

Two important new facets were discussed in depth:

(a) A short-term response to the need for existing types of users' equipment to connect to public networks has led to the introduction of intelligent networks that are adaptable to existing computing protocols.

(b) A long-term evolutionary approach by the public-service corporations envisages the integration of all types of message through the integrated services digital network (ISDN).

### Public Data Networks

Several papers were presented showing the progress of public data networks, and there was a wide range of approaches. A review paper by P. T. F. Kelly, British Telecom (BT), noted that the services provided by the EEC-sponsored\*\* EURONET would be taken over by national packet-switched networks as these matured (17 were expected to be operating in 1984) and were interconnected via gateways.

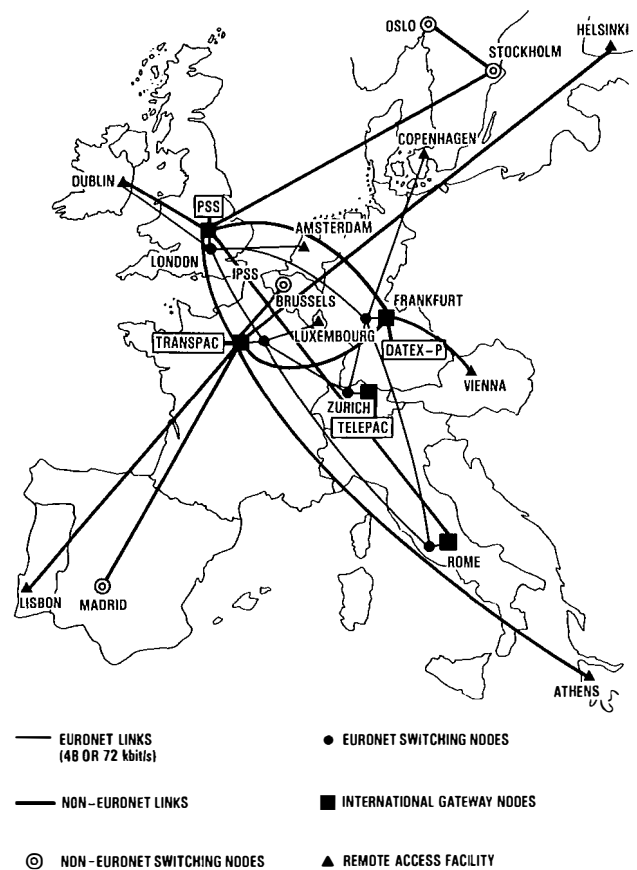

EURONET layout at mid-1983

ched networks as these matured (17 were expected to be operating in 1984) and were interconnected via gateways.

Significant statements on particular public networks were as follows:

(a) The French TRANSPAC network continued its expansion; a forecast of increased facilities and new features was made from its base of 6000 users.

(b) The DATEX-P packet-switched network of the Deutsche Bundespost was being adapted to give compatibility with manufacturers' proprietary terminal protocols (for example, packet assembler/disassemblers (PADs) for synchronous block mode).

† Mr. Williams was a consultant to British Telecom as the coordinator for ICCC '82

\* CCITT—International Telegraph and Telephone Consultative Committee

‡ ISO—International Organization for Standardization

\*\* EEC—European Economic Community

(c) The Nordic data network, initially circuit switched, was being enhanced to give access to a packet-switched network, and was seen as a step towards a future ISDN.

(d) The Italian data network being developed by *Societa Italiana per l'Esercizio Telefonica p. a. (SIP)* would be opened in 1983.

(e) Both Telecom Australia and BT were implementing digital leased-circuit network services using synchronous time-division multiplex transmission.

(f) In the USA, a notable step by the American Telephone and Telegraph Company (AT & T) was the announcement of the Bell System packet transport network, conforming to CCITT Recommendations and to be a bearer of enhanced services. Under the title of *The Intelligent Network*, a co-ordinated presentation was made by speakers from Bell Laboratories, AT & T, and the new unregulated subsidiary American Bell Incorporated (now AT & T Information Systems), of NET/1000, which is planned to be available at 100 to 200 nodes by 1988. NET/1000 will provide a range of value-added customers' services that allow established types of terminal and computer to be connected; that is, it will be able to carry out protocol conversions within the network service nodes.

A further sign of the maturity of public data networks was the attention being given to performance, testing and management aspects, as described in contributions from France, the Federal Republic of Germany (FRG), the UK, Canada and Japan.

### Integrated Services Digital Network

Two sessions were devoted to plans and strategies for the ISDN. Although there was cautious agreement on the eventual convergence of speech and non-speech services, there was a wide range of opinion on the details and time-scale. Possibly, some differences in the starting points were contributory, particularly on whether the ISDN was approached from a telephony position, that is, the availability of a switched 64 kbit/s transparent digital path as the basic transport channel for pulse-code modulation encoded telephone speech, or from the data network position based on X21 or X25 access protocols. An important theme was that of uniform access methods to multi-service networks, aimed at simplifying arrangements at customers' premises and conserving investment in local cable plant. The CCITT's recent definition of a multi-service interface was the basis of several papers on local access.

A paper from the TransCanada Telephone System (TCTS) (now Telecom Canada) considered the opportunities for integrating speech and non-speech services from the users' viewpoint, and noted commonalities between services, management and network design. Several papers emphasised the special characteristics of data traffic; for example, the independence of forward and backward transmission, the possibility of short holding times and the need for fast set-up of calls.

A longer-term view by C. J. Hughes, BT, introduced the concept of variable-bit-rate switching and, noting the importance of time delay as a constraint, preferred the design to be based on synchronous dynamic slot allocation, rather than store-and-forward techniques. A Bell Laboratories paper by L. F. Ludwig considered the problems of a 'digital pipe' with dynamic bandwidth allocation.

## NETWORK TECHNOLOGY

### Network Interconnection

Network interconnection was the subject of several papers. The influence of CCITT studies was noticeable in the adoption of its interworking protocol, X75, and its numbering scheme, X121, to provide interconnection of the Canadian DATAPAC network with 9 other networks, while the BT

Telex/Packet SwitchStream (PSS) interworking scheme used a remote PAD with X75 for connection to PSS.

IBM authors described how the proprietary Systems Network Architecture (SNA) could accommodate public network links within an SNA network or allow connection of non-SNA terminals.

By contrast, 2 papers on the pioneering ARPANET served mainly to illustrate the advances made possible by channeling network design along internationally-agreed lines.

### Switch Architecture

The session on switch architecture was concerned with trends in the design of packet switches towards high throughput and high reliability. There was general agreement in papers from France, Finland, the UK and Japan on the use of a multi-microprocessor architecture; the SCIPION project of *Centre Commun d'Etudes de Télédiffusion et Télécommunication (CCETT)* and *Terminaux Integris de Telecomm (TIT)*, France, was aimed at a throughput of 20 000 data packets per second by using autonomous switching modules (up to 8 Mbit/s capacity) interconnected by multi-level busses.

### Optical-Fibre Systems

Two sessions on optical-fibre systems covered 2 main areas of application: in local area networks as an alternative to metallic conductors, and as transmission bearers in the general telecommunications network. In the latter usage, the New York Telephone Company found a solution to long-standing problems of duct congestion in metropolitan areas, while authors from Standard Elektrik Lorenz, FRG, reviewed the scope for optical-fibre systems for broadband local communication, with particular reference to the BIGFON project sponsored by the Deutsche Bundespost.

### Communications Satellites

Communications satellites featured in 2 configurations. In a broadcasting mode, the NADIR project in France would use the TELECOM 1 satellite to transfer large volumes of data point-to-point at high speed (for example, 10 Mbytes in 1 min) with appropriate protocols being developed. Authors from the Ministry of Posts and Telecommunications, Japan, described the use of a domestic satellite (in the 20–30 GHz band) to interconnect many terminals at small earth stations with a central computer. A novel proposal by S. Ramani, India, and R. Miller, USA, was aimed at providing a message store-and-forward service for territories lacking a developed communications infrastructure. It involved the use of a satellite in low-altitude orbit having an on-board message-switching computer that would poll a very large number of small earth stations, collect data or messages and transmit them with addresses to be received around the world.

A session on integrated satellite systems, linking local networks in a distributed computing system, featured 3 large-scale projects:

(a) STELLA, the first European wideband data transmission experiment, involving the transmission of experimental data among high-energy physicists at several centres;

(b) NADIR, a joint French PTT†/French Ministry of Industry experiment using the TELECOM 1 satellite to link large companies for business communications; and

(c) UNIVERSE, the UK universities extended ring and satellite experiment for computer and business communications.

† PTT—Post, Telephone and Telegraph Administration

## LOCAL RADIO, ROUTING AND FLOW CONTROL Packet Radio Systems

Packet radio systems for interconnecting a central computer with several remote terminals have been of continuing interest since the ALOHA project, although mainly at a research level. A session on this topic comprised papers on an analytical level dealing with queueing, interference and throughput.

### Routing and Flow Control

Routing and flow control of packet-switched networks have formed a key element in ICCC Conferences since their inception, and have been inspired by the key work of the ARPANET community. A sound theoretical basis for network design now exists, as is evident from the commercial success of packet-switched networks in private and public service. Papers presented at ICCC '82 were analytical in nature and dealt with throughput when 'go back  $n$ ' retransmission protocols were used; routing algorithms for alternatively-routed networks and their effect on costs; priority scheduling disciplines and a method for collecting network information for use in a call-routing algorithm.

## LOCAL NETWORKS, OFFICE SYSTEMS AND TEXT/MESSAGE TRANSMISSION

Eight sessions were allocated to various aspects of information systems and their use in the evolving automated office. Initially distinct and separate computer-based message systems (CBMSs) and enhanced telephone PABXs are now converging into comprehensive business support systems. A user does not want to be presented with discordant elements competing for his attention, each having its idiosyncratic operating features that have to be learnt and re-learned. The idea of the electronic desk on which all necessary services are available in a co-ordinated way, to the exclusion of all unnecessary paper, is now seen as an attractive and feasible prospect, and was a theme of several papers.

### Local Networks

Local networks made their initial impact in research communities; hence, the evolution of standards followed a different course from that of public data networks since the public telecommunications organisations and the CCITT were not involved. However, intensive discussion of standards in the European Computer Manufacturers Association (ECMA), the International Federation for Information Processing (IFIP) Technical Committee 6 and in an IEEE Committee was in progress during 1982, and the opportunity was taken for the progress of these discussions to be reported at ICCC '82. At that time, it was noted that IEEE Standard 802 was at the draft stage for logical link control, for access methods and physical layers for CSMA/CD† and token-passing systems. ECMA studies were closely aligned with the open systems reference model of the ISO. The ECMA's proposed protocols at layers 1-4 differed from wide-area protocols by omitting virtual calls and flow control, since congestion and errors on local networks can be assumed to be of less importance. Support for the open-systems concept and independence from manufacturer-specific protocols was given in papers by authors from ISPRA, Italy, and from the Joint Network Team (Computer Board and Research Councils, UK).

Other papers dealt with specific implementations or studies outside the current standards stream. A paper by Li and Li, USA, addressed the particular requirements of

† CSMA/CD—Carrier sense multiple access with collision detection; for example, Ethernet

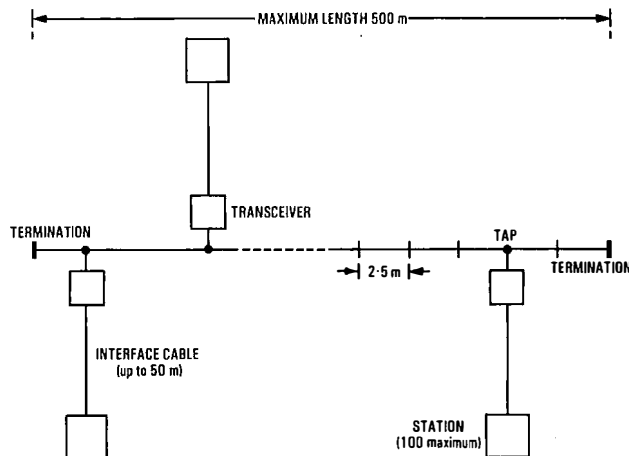

A single-segment Ethernet configuration

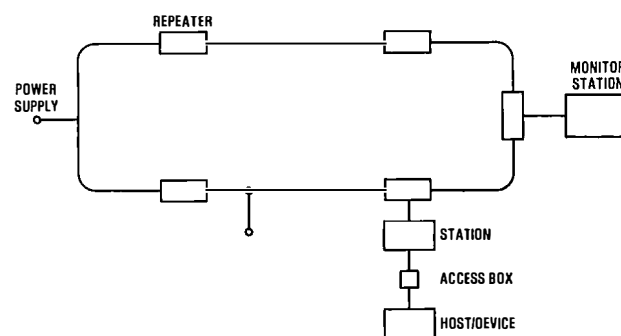

The Cambridge Ring

speech transmission for predictable time delay and the known shortcomings of contention protocols (such as CSMA/CD) in this respect. A particular collision-free protocol adapted to local area networks with clustered terminals was analysed and shown to be suitable for integrating speech and data.

The standards activities noted above do not specifically address ring-type networks with circulating packets; 2 papers from the University of Kent at Canterbury, UK, described practical experience with a Cambridge Ring in operational use in the University's computer service. Management facilities and reliability were described, together with a description of a gateway giving access to external resources and networks. Accounting and control of access to external resources were seen as essential facilities in the gateway. These were provided in the gateway database and were inaccessible to users.

### Office Systems, Standards and Strategy

The 3 sessions on office systems, standards and strategy were planned as informative sessions, with the interests of business, commercial and industrial managers as users of an expanding range of communications services in mind. Two papers on strategy from British Leyland Systems Ltd. (BLSL) and one from a Canadian consultant were addressed to senior management and noted the need for defining the operational needs of an organisation, including internal attitudes to change, and for devising an evolutionary application of office systems in ways that could be shown to be relevant to the success of the organisation. Emphasis was given to providing the user with a consistent procedural interface for all interactions. Acceptance might be aided by

including features already familiar in the traditional office environment, such as notice-boards.

BLSL had adopted an evolutionary strategy to form the basis of its use of information technology to meet its business needs. The strategy covered data, text, image and speech that British Leyland needed to be transmitted between its sites. Differences in the computing protocols would be overcome in the long term by the adoption of international standards following the open systems route. Short-term interconnection would be achieved by converting to IBM protocols used by the existing terminals (HASP, 3270 etc.). R. A. Clark, Joan de Smith Systems and Computex Systems, UK, noted that standards would allow users to capture and process information before passing it on to other users, thus permitting successive value adding. He referred particularly to document standards, the theme of a paper from Professor Kirstein and S. W. Treadwell of University College, London. This paper discussed the extension of present service standards—for example, for Teletex and videotex—to cater for multi-media document processing systems based on the open systems reference model.

### Computer-Based Message Systems (CBMSs)

Standards for CBMSs were reviewed by S. Watkins, National Bureau of Standards (NBS), USA, as part of an NBS work programme aimed at facilitating information exchange among automated offices. The NBS paper described a proposed message format and protocol being formulated within the context of the international standards activities in the CCITT and ISO. European work on interconnecting CBMSs to provide electronic-mail facilities was being carried out under the COST 11bis† project sponsored by the EEC under the sub-project GILT\*, and was described by E. Fergus (Atomic Energy Research Establishment (AERE), Harwell) on behalf of the GILT participants in several European countries. The GILT message standard was based on an abstract model of a CBMS and used protocols based on X25 and Teletex standards with extension up to level 7 of the open systems interconnection (OSI) architecture.

Public services aimed at supporting office systems were described by authors from Bell-Northern Research (BNR), Canada; TCTS and BT.

iNET—the intelligent network—was a new set of services to be added to the Canadian DATAPAC X25 service to give the office user an integrated network access system by which an ASCII or videotex terminal could be used for a range of information services, thus giving the user an 'electronic desk top'. The architecture of iNET comprised network access nodes, which provided the users' environment. The iNET protocol followed CCITT standards closely, being based on X25, X29 and the Teletex standards.

ENVOY 100, an existing public text messaging service operated by TCTS over the DATAPAC network, was planned to allow message transfer with other electronic-mail systems in North America and overseas. TCTS interconnection plans were in line with current CCITT proposals and used a protocol structure consistent with the OSI model; a message-transfer layer and a user-agent layer would probably rest upon the Teletex session layer protocol.

The BT paper outlined the design of a 2-tier information service embodying the proposals already made to the CCITT for a standard document structure for enhanced Teletex. The first tier would comprise an electronic-mail service, while the second tier would be an information exchange service within which the key element would be a universal standard document having a structure for the interchange

† COST 11bis is a project supported by a group of European countries under an agreement for CO-operation in Science and Technology

\* GILT—Get Interconnected Local Text systems



A Teletex terminal

of data among word processors, work stations etc. The service would be perceived by the user as the top of an office desk, documents being visible as images seen through multiple windows.

Teletex standards were referred to in several papers, while Teletex itself as a defined public text exchange service was the subject of 2 full sessions. Although not necessarily linked to a specific terminal apparatus, several manufacturers and public telecommunications organisations have developed stand-alone Teletex terminals to support national services. Papers from the Deutsche Bundespost, Swedish Telecommunication Administration and BT outlined service plans based on the public networks DATEX-L†, DATEX\*, and public switched telephone network (PSTN) and PSS, respectively. The papers covered field trials and initial service experience, possibilities of interworking with Telex, and the scope for a range of terminal facilities from simple typewriter-oriented to word-processor or complex business-system facilities.

Other papers on Teletex dealt with encipherment and the authentication of signatures (as enhancements of Teletex procedures based on the data encryption standard), design guides for a Teletex PABX and desirable developments and enhancements of Teletex terminals, needed to meet users' requirements in multi-site drafting and editing of documents.

### The PABX Approach

The session on *The PABX Approach* was planned to give an opportunity for the new technologies now appearing in designs of telephone PABXs (stored-program control (SPC) by central and peripheral processors, digital transmission and switching) to be displayed, with the scope for providing integration of speech and data communications in the automated office. Inevitably, comparison is made between the traditional star cable network associated with the PABX and the bus or ring network associated with current designs of local data networks. However, in practical terms, ring or bus systems are likely to need spurs to individual terminals, while digital PABXs will have internal ring or bus architec-

† 2400 bit/s circuit-switched network

\* Nordic circuit-switched data network

tures; so the difference may be in scale rather than in topology. Most of the papers noted the advantage to management in PABXs being able to use existing cabling to carry new data traffic and so avoid the cost of a second cable run. Possibly, the PABX and the local area data network should be seen as complementary; this emphasises the gateway function of the PABX and the high-speed capabilities of the local data network. Convergence to a fully-integrated speech/data system should be seen, perhaps, as a long-term eventuality.

Specific aspects of the 6 papers presenting the PABX approach to office systems can be summarised as follows:

(a) *Nippon Telegraph and Telephone Public Corporation (NTT), Japan* The design of an experimental electronic PABX was outlined; it used a 64 kbit/s time-division multiplex switch. Digital telephones and X21 or X20bis data terminals, or an integrated telephone and personal computer could be connected. Problems noted were the need for sub-addressing to identify specific data terminals, and the probable dominance of voice traffic from the point of view of loading.

(b) *IBM, USA* Problems of combining data and voice traffic in a digital SPC PABX, primarily switching 64 kbit/s channels, were considered. Contrasting its capabilities with those of a high-speed local data network, the author concluded that a combination in which the PABX would handle all telephone calls and act as a gateway for data calls on the PSTN would be the best solution.

(c) *AT & T, USA* Noting the slowness of the automated office to materialise, the paper proposed an evolutionary approach through the PABX as the central element, and listed the evolutionary capabilities that the PABX should have.

(d) *Bell Laboratories, USA* An advanced PABX networking scheme was described in which each PABX would have a data communications interface associated with its central processor. These would be interconnected by data links and would operate as an X25 packet-switched network for transmitting data messages concerned with call set-up and call clearing.

(e) *Bell Laboratories, USA* Continuing the theme of an orderly evolution via the PABX into the automated office, this paper described a digitally multiplexed link that used existing extension wiring to carry speech, data and signalling.

(f) *ITT Business Systems, UK* This paper gave a comprehensive series of detailed comparisons of the scope and characteristics of local data networks with PABXs. Essential elements of local data networks were high-speed transmission, low error rate, and a ring or bus topology serving a single site. Unlike PABXs, which were strongly linked to PSTN standards, local data networks were at present not tied to standards and appeared to be able to exploit new technology and to be adaptable to changing requirements. Analysis of traffic patterns distinguished between in-group, within-site and external traffic, and with a further distinction on the basis of data and transaction rates, indicated the range of applications for current types of PABX and local data network. For the future, a phased evolution was foreseen beginning with the two side by side and, eventually, leading to a general convergence of technologies with the local data network becoming absorbed within general information systems.

### Videotex

A session on videotex gave an opportunity for the state of this emerging world industry to be reviewed a decade after its invention in the British Post Office Research Laboratories. Videotel in Italy and Bildschirmtext in the FRG were initially based on the British Prestel service. A significant contribution was made by the Deutsche Bundespost in its development of the gateway concept, which gave access to

private databases and, subsequently, was incorporated in Prestel. A paper from BVT Logica, USA, noted that neither teletext nor videotex had been implemented commercially in the USA. A wide range of information services was likely to develop and these would be tiered to allow differential pricing. Full-channel teletext and interactive teletext transmitted via broadcast and cable systems were expected to become part of comprehensive consumer-oriented services.

### DISTRIBUTED SYSTEMS, NETWORK ARCHITECTURE, OPEN SYSTEMS INTERCONNECTION AND PROTOCOLS

These topics were shared among 7 sessions, although they are closely related. A useful introduction was given by Dr. P. K. Verma, Chairman of the session on *Information Network Architecture*, which he defined as dealing with the overall framework under which resources of a network are organised and managed in order to meet the demands imposed upon it. An information network has resources, processing, storage and transport for use in an environment which may be price sensitive and reflect changing users' demands. The network should respond to changes in technology and costs and must be flexible, because it is not yet possible to synthesise an information network architecture.

Dealing first with resources, 2 papers from authors in International Computers Ltd. (ICL) discussed databases, one from the point of view of centralised database management and the trend to move storage near to its main users; design and management problems led ICL to develop a new distributed database management system. The second paper considered the effect of limited speed of data links on the response time and, hence, the acceptability of the service. Present low data rates on wide-area networks imposed constraints on synchronous updating.

A third ICL paper dealt with the content-addressable file store (CAFS), which could be attached to a host computer as an extension to a disc control unit. This provides a high-speed data search-and-retrieval service to solve some of the problems posed when files are distributed around an organisation, but are to be accessible via local or wide-area networks.

A paper from Siemens presented a formal framework for the interworking of Siemens Transdata products for teleprocessing. It provided an illustration of how a teleprocessing architecture was developed to take advantage of existing PTT transport services as well as standard communication interfaces and protocols.

Other papers on distributed systems and network architecture included an analysis of a model of a multi-processor system and a proposal to use a very-high level definition language to define complex messages so as to facilitate communication among network entities. A Bell Laboratories paper proposed a byte-oriented transport structure that gave a simple service interface to the user, the basic service being a virtual circuit carrying an unstructured stream of bytes that are distinguished as to whether they are data or control. The virtual circuits are implemented by using packet switching and statistical multiplexing in a way that is transparent to the user. The aim of the proposal was to simplify terminal-to-terminal communications and to accept evolving technology. It arose from a research study into modular network design.

Bell-Northern Research, Canada, addressed performance-related questions in information networks and presented specific strategies used for achieving high reliability and availability in Northern Telecom's packet-switched networks based on the SL-10 switching system.

### Open Systems Interconnection

The sessions on OSI were planned in tutorial sessions so that a survey could be given of the progress in international

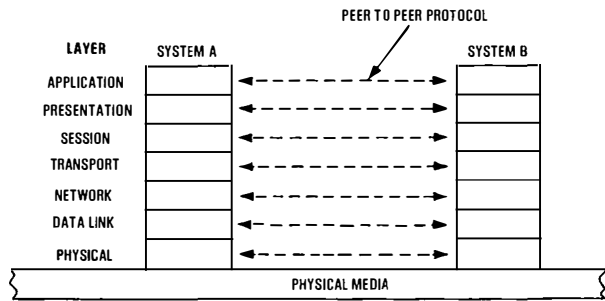

The reference model for open systems interconnection

standards. The importance of the topic will be evident to the reader from the numerous references to the OSI model in many papers covering a wide range of topics. As Professor Schindler pointed out in his introduction to his Conference paper entitled *The New Keywords in Communications Technology and Office Automation*:

'a considerable effort was undertaken to work out the fundamental concepts of computer communication and to make the insights so obtained operational by developing international standards—in short, the development of the architecture of "Open Systems" was initiated'.

Five papers gave a general review of OSI standards activities, beginning with an introduction by B. M. Wood, Computer Analysts and Programmers Ltd. (CAP), UK, in which the involvement of the ISO and CCITT was noted and the status of the reference model itself given as that of a draft international standard. An estimate of the time-scales in reaching effective agreement on draft standards for the individual 7 layers was given and these ranged from 1982/3 for the transport layer to 1986 for the other standards. Problems in achieving these dates were pointed out; the complexity of the work and the need for national support while the relative novelty to the computer industry, unlike the telecommunications industry, of working to prospective rather than retrospective standards had yet to be put to practical test.

The lower layers of the OSI model were discussed by J. Tucker, Logica, UK. In particular, he clarified the boundary between the network and transport layers and concluded by considering the application of the OSI concept to real interworking situations, dealing in some detail with local area networks. In this connection, he noted the standards work on local area networks in progress in the IEEE and that further work would be necessary in order to relate the local area network service to the OSI model.

The transport layer was introduced by K. G. Knightson, BT, as being of great importance in the OSI reference model and being under consideration for many purposes, including facsimile, Teletex, videotex, electronic mail etc., because its function is a general one of controlling the transportation of data between a source end-system and a destination end-system. He outlined the protocol classes of transport layer that had been agreed by the ISO and CCITT committees and the types of network connection that they were intended to cater for. An international standard for the transport layer was expected to be agreed in the near future.

The upper layers, covering the session, presentation and application layers of the OSI model, were discussed by P. F. Linington, Cambridge University Computer Laboratory. He described in some detail the concepts involved in the presentation and application layers. For the application layer, the concept of service elements has been introduced to give the necessary flexibility; these could be defined for common activities or complete protocols. Such protocols for file transfer, access and management, virtual terminal and job transfer and manipulation were already in hand. He

was concerned to remove misconceptions that saw the OSI standards as restrictive on design, and emphasised that they gave benefits of a modular structure that do not preclude specialisation where needed.

Two papers from participants in the standards work of the ECMA described proposals from that body now under consideration in ISO Committee. The first paper discussed the ECMA session layer protocol, which had the status of an ECMA standard and was being implemented in actual networking environments. The second paper reviewed the ECMA's approach to virtual file protocols that standards should be based on the characteristics of existing file organisations, and gave an overview of a draft ECMA standard for a basic file transfer service.

## Protocols

Protocols—rules governing interactions between processes possible in a network—have become an intrinsic part of the technology of computer communication. In one form or another, protocols featured in most of the sessions of the Conference. The co-ordination of studies and standardisation through the ISO and CCITT has channelled the study of communication protocols along clearly defined paths, as was shown in the sessions on OSI. Nevertheless, a range of papers was presented at ICC '82 that gave reviews, experience and assessment of protocols at all levels in the hierarchy. Protocol proving and validation is now seen to be a critical area for development, and a whole session was devoted to this topic. A selection of topics from papers presented during the sessions on protocols follows:

(a) *NTT, Japan* This paper considered the problem of adapting the large number of frame-mode terminals already existing to connection to an X25 packet-switched network. Particular terminals considered used high-level data link control in normal response mode polled from a central computer. The paper concluded that the best solution was an X25 connection for the host computer with slave terminals connected to a remote PAD and polled from the PAD.

(b) *IBM, USA* This paper reviewed the SNA and its use for constructing a network of IBM products, which may also include virtual circuits provided by an X25 data network and non-SNA terminals.

(c) *National Physical Laboratory (NPL), UK* This paper reviewed the possibility of including encipherment within the definitions of OSI, and considered the locations where encipherment should be carried out and the management of keys.

(d) *NBS, USA* This paper described specifications for a presentation layer protocol, consistent with the ISO's work, which had been prepared for adoption by Agencies of the USA federal government.

(e) *University of Salford, UK* A paper by J. Larmouth described an interim standard for job transfer and manipulation that had been adopted by the university community and was known as the *Red Book JTMP*. The author saw the interim standards work as leading to a general framework for distributed processing.

(f) *University College, London* A paper by P. L. Higginson and R. Moulton gave an account of experience with a network-independent file transfer protocol developed by a group of users of the UK experimental packet-switched service.

(g) *Bell Laboratories, USA* This paper described the Bell BX25 protocol, a vendor-independent protocol standard for use on the Bell System operations network. It is compatible with X25 for DTE-DCE† connections but includes layers of protocol above X25. These features permit the

† DTE and DCE refer to CCITT terms *data terminal equipment* and *data circuit-terminating equipment*, respectively



network to use a variety of existing communications services and to migrate to X25 networks as they become available. The BX25 architecture was based on using the multiplexing, flow control and error-recovery functions inherent in X25 as a base for simple higher-level protocols that do not duplicate the X25 functions.

(h) *IBM, Switzerland* Research workers at the IBM Laboratory in Zurich have devoted considerable efforts to the study of protocol validation and proof. The author of the paper presented at ICCC '82 outlined the application of a validation technique to the analysis of CCITT Recommendations X21 and X25 (level 3), and described the technique and possible future developments.

(i) *NPL, UK* This paper described the work of the NPL Protocol Standards Group in developing testing techniques for the assessment of protocols that have been implemented in manufacturers' systems, and outlined proposals for a pilot validation service.

(j) *AERE, Harwell, and BT* In this paper, the authors proposed to simplify the task of validating network service protocols such as Teletex, X25 level 3, Transport etc. by implementing them as standard packages in the ADA language.

## USERS AND THE SOCIAL ENVIRONMENT

Under this broad heading, 8 sessions at ICCC '82 considered applications, regulatory and public policy issues, economics and human factors.

### Banking and Electronic Funds Transfer

Three papers on banking and electronic funds transfer showed that these applications have the following special features: speed, security and reliability, wide geographical coverage and independent but co-operating entities.

The Reuters monitor dealing system (Reuters and CAP Group, UK) was described as an international information transfer network connecting 345 banks in 22 countries, based on packet-switched nodes with controllers and concentrators for the special terminals located in the participating banks.

Another bank network, for the Sanwa Bank, Japan, was described by authors from Sanwa Bank and Hitachi. It is a packet network with main nodes at Tokyo, London, Hong Kong and New York. Information is sent over the network either as real-time packets or as stored and re-transmitted computer data.

A general review paper by 2 Canadian authors presented a simple conceptual model of a bank's function and its consequential system requirements in relation to the reference model for OSI.

### Education

Papers on education covered the use of course material for the Open University in radio broadcasting, an interactive audio-visual experiment and 2 university network schemes for interconnecting resources and users in the academic community.

Authors from *Istituto del Consiglio Nazionale delle Ricerche*, Italy, described experience with RPCNET, the Italian computer network, which has been in operation since 1976. Problems resulted from lack of initial standards, restriction to one manufacturer's operating system and modifications that impose a heavy software maintenance burden.

A paper from the Joint Network Team of the Computer Board and Research Councils, UK, provided an interesting contrast to the RCPNET paper since it described a standards-first approach to the same goal. Much of the available research effort over the past few years has been devoted to fundamental work on the evolution and implementation of protocols and to the promulgation of the standards concept. Several of the participants in this work took part in the

planning for ICCC '82 and presented papers. The clarification given by the structured approach now being defined as the OSI model has enabled the academic community to see its long-term objective and to set short-term targets with the assurance of long-term convergence.

Two final papers on applications drew attention to the potential of computer communication for handling information on a global scale for medical and disaster relief.

## Regulatory and Policy Issues

Regulatory and policy issues were dealt with in 3 formal papers, a progress report on the UK government's liberalisation policy and a panel discussion of the problems associated with transborder data flow.

H. P. Gassman from the Organisation for Economic Co-operation and Development (OECD) noted that the OECD had set up a Committee with 4 themes on various aspects of information technology, including one on international information flows. The OECD had previously adopted a set of guidelines on privacy, which have had wide support and acceptance. Eight European countries have enacted general data protection laws in accordance with the guidelines, while other protection measures have been taken by other countries and organisations. Although there was little evidence that such measures had presented a real barrier to international business, an OECD expert group on transborder data flow was investigating the economic and legal aspects. The OECD was also interested in the effects of the costs of telecommunications services on business operations and the variations of tariffs between countries.

In the discussion on transborder data flow, it was noted that data protection was aimed at personal data, which was estimated to account for less than 5% of international data traffic.

The legal foundation for the control of transborder data flow was currently being studied by the OECD; provisional conclusions were that the existing legal framework was adaptable to cover international data traffic, at least in part. If a new legal regime were adopted, it would have to come to terms with:

- (a) economic and financial agencies;
- (b) governments' concern with public order, security and taxation; and
- (c) citizens' rights and obligations.

Dr. S. Weinstein, American Express, USA, summarised his view of governments' interest in transborder data flow as:

- (a) fostering foreign trade;
- (b) relating to its national information processing industry;
- (c) earning revenue from carrying, processing and taxing data;
- (d) defending its domestic interests in culture and ideology; and
- (e) protecting national security, privacy and intellectual property.

He noted that there were many tariff and non-tariff barriers that could be imposed.

Dr. K. Schmid, Ministry of Posts and Telecommunications, FRG, addressed one particular topic that might prove an obstacle to data flow—national policy on availability for unrestricted use of leased lines—and explained the Ministry's policy on the harmonisation of tariffs that led to the introduction of volume-sensitive tariffs for leased lines.

C. Dalfen gave a Canadian viewpoint, noting that government concern was about the harmful effects of transborder flow; a Task Force had been set up by the government of Canada to report on economic and sovereignty considerations.

M. Tyler, USA, reviewed the changing legal and regulatory framework facing the telecommunication service organisations in several countries in the light of trends towards competition in the supply of these services. The national policies of OECD member countries were reviewed and a brief outline given of the issues that should be considered in an evaluation of national strategies.

P. A. B. Hughes, Logica, UK, presented the arguments in favour of telecommunication monopolies, boldly facing the reality of political motivation behind preferences either for monopoly or for competition. He presented the arguments for preservation of a monopoly as follows:

(a) avoiding cream skimming, which leads to penalties for small business and residential users;

(b) long-term investment, standards and major innovations are better secured with monopoly, as is international co-operation; and

(c) competition requires regulation with consequential problems, delays and formality in procedure.

J. P. Compton, Department of Industry, UK, summarised the progress of liberalisation as at September 1982. He described the government's aim in establishing standards through the British Standards Institute (BSI) and the independent approval procedures for attachments to BT's network. He referred to his Department's concern to safeguard the public interest in telecommunications services against 'pollution', since market forces were unlikely to be effective. The Department was devoting considerable effort to simplifying approval procedures and reducing the criteria needed for approval.

### Pricing and Allocation

The session on pricing and allocation can be described as covering both micro- and macro-economic issues. Three papers dealt with service and network pricing; 2 papers dealt with national economics and complemented the discussion on public policy in that session.

J. Muller, Institute of Economic Research, FRG, analysed the development of a cost-based tariff policy for public telecommunication services in the context of new technologies and competition among providers of services. He foresaw that the consequent disappearances of cross-subsidies would lead to inequitable tariffs, which might, in the long run, be found to be politically unacceptable.

C. Jonscher and A. Balkanski, CSP International, USA, outlined the studies being carried out by a research team funded by the ITU† and other bodies aimed at quantifying, in cost/benefit terms, the gains in economic efficiency made possible through the expansion of telecommunications. The methodology was explained, with some initial conclusions from studies of a particular national economy.

### Human Factors

Human factors were prominently featured at ICCC '82, in keeping with the aims of the ICCC to balance technical and social issues. Three sessions were devoted to this topic, but it must be admitted that the emphasis in all papers was primarily on mechanisms for improving the overall effectiveness of the complete computer system, with the human being as just one element. Only one paper (by Professor Hiltz) examined wider issues. It was perhaps significant that the Chairman's introduction to one of the sessions on distributed systems (D. L. A. Barber, Logica, UK—*Human Factors in Open Systems Interconnection*) proposed that layers above the present OSI reference model might be defined to cater for the human interface.

Seven papers in the sessions on man-machine interfaces

and friendly systems examined a specific problem or problem area in system design. One topic of interest (raised by system designers rather than by users or implementors) appeared to be whether users should be consulted before definition started or merely asked to assist in refining an initial system.

Two papers from BT authors (A. Kidd and A. R. Willis) were relevant to the design of voice-information subsystems for future telephone systems. Particular design problems of auditory 'menus' were considered, together with general users' requirements that are important in system design.

Of the 2 papers from the Medical Research Council's Applied Psychology Unit, one analysed the problems experienced by non-expert users of computer systems in communicating with the system; the other (carried out under BT funding) presented an analysis and conclusions from studies of users' difficulties with the Prestel service, which were aimed at leading to rules for writing videotex frames.

B. Huckle, Hatfield Polytechnic, noted that the typical interface to a time-sharing computer service deters inexperienced potential users. Her paper discussed the requirements for a unified interface and described an implementation.

Two papers (by Professor S. R. Hiltz, New Jersey Institute of Technology, USA, and M. Pieper, Institute for Planning and Decision-Support Systems, FRG) considered broad effects of the availability of computer-communication systems on users' habits. In one study, a CBMS available to a scientific research community was used as a complement to existing means of communication (including mail, transport etc.), rather than as a replacement. In the second study, a computer-conferencing system was available to workers on a common project; it was in fact used as a CBMS and hardly at all for its intended conferencing purpose. Sociological interpretations led to recommendations for improved system design.

A paper from H. T. Smith, Nottingham University, drew attention to a range of users' interests in CBMSs that appeared not to be receiving attention; typical information about the status of a recipient might have privacy/security connotations, while delivery/receipt confirmation might be required or declined. He suggested that a class of service should cover user protection of access. D. Biran, Ministry of Communications, and R. Feldman, Jerusalem College of Technology, Israel, discussed some of the main topics in multilingual electronic-mail services, and considered some possibilities for standardising prompts and commands.

L. J. Endicott, Jnr., IBM, USA, discussed an experimental project aimed at making available to untrained personnel all or most of the data processing functions that might be required by a small business. Basically, the system interface provided a set of menus and prompts so that users could generate and modify billing, inventory control ledger and payroll applications programs. Three modes were found to be necessary:

- (a) education,
- (b) for experienced users, and
- (c) for inexperienced users.

The author speculated on the possible effects of school familiarisation with computing on the level of future novices and on the possibility for expert systems being developed for the business user.

### References

<sup>1</sup> WILLIAMS, M. B. The Sixth International Conference on Computer Communication: A Review. Part 1—The Plenary Sessions. *Br. Telecommun. Eng.*, Apr. 1983, **2**, p. 38.

<sup>2</sup> WILLIAMS, M. B. (*Ed.*). Pathways to the Information Society. Proceedings of the Sixth International Conference on Computer Communication, Sept. 1982. North-Holland Publishing Company, Amsterdam.

<sup>3</sup> Conference Report, *Computer Networks*, June 1983, **7**(3), pp. 141–203.

† ITU—International Telecommunication Union

# Royal Videoconference for STD Anniversary

BRITISH TELECOM PRESS NOTICE

On 21 November 1983, Her Royal Highness Princess Anne marked the 25th anniversary of subscriber trunk dialling (STD) when she called Mr. Tom Morgan CBE, the Lord Provost of Edinburgh, from the Bristol Confravision studio. Her Majesty The Queen's call to inaugurate STD, on 5 December 1958, was also made from Bristol to the then Lord Provost of Edinburgh. On that occasion the Queen and the Lord Provost were able only to speak to each other. The advance of technology during the past 25 years has made it possible for the 2 participants now to see, as well as hear, each other.

During the next few years, a similar 'picturephone' service, known as *videoconferencing*, will become almost commonplace for British business. British Telecom (BT), in collaboration with its partners in the European Economic Community, has developed a transportable picture terminal, which will enable users to hold videoconferences from their own offices or meeting rooms. Trials of this British-made equipment will involve about 20 businesses. During 1984, BT plans to start a commercial service within the UK, to be called *VideoStream*, and a transatlantic service, first with Canada and later with the USA.

The telephone service in Britain has been transformed since the start of STD 25 years ago. A dial-everywhere network has been established, and is now run by BT National Networks in conjunction with BT Local Communications Services.

Direct dialling of long-distance calls is taken for granted, not only throughout the UK, but widely overseas. Britons make nearly 10 million trunk calls a day—more than 3500 million a year—and dial nearly 99% of them direct. There are now nearly 30 million telephones, connected to 20 million exchange lines, in Britain, compared with 7 million telephones and 4.5 million lines in 1958. More than 98% of the annual total of 320 million international calls are also dialled direct; this is another communications transformation that stems from the modest introduction of international direct dialling between London and Paris 20 years ago. Now, at the turn of a dial, or the push of a button, users can call more than 500 million telephones in 136 countries.

The great attraction of STD has always been its cheapness, because the charge for a call became directly proportional to its duration. In 1958, a 1 min call of up to 35 miles cost 4d (about 1.5p) to make instead of a shilling (5p) via the operator, while a 3 min call over the greatest distance came down from 3s 6d (17.5p) to 2s 6d (12.5p).

Today's STD calls are even better value for money. In real terms, their cost is nearly half of what it was in 1958. For example, a 3 min trunk call costing 2s 6d in 1958 would be 87.5p at today's prices, compared with 61p that users actually pay today (including value-added tax), or even 46p at the lower charge rate that was introduced for long-distance calls last year.

Britain is now on the threshold of an even greater communications revolution than that of STD. With the modernisation of Britain's network based on System X and other modern electronic exchanges, many new services and facilities will become available.

The STD service was made possible by the use of group routing and charging equipment (GRACE), which mechanises the functions of the operator in setting up trunk calls. This equipment notes the telephone number required, selects the correct route to that number and charges for the call at the appropriate rate.

With the GRACE came the concept of national num-



Her Royal Highness Princess Anne in the Bristol Confravision studio making the call that marked the 25th anniversary of the STD service



Her Majesty The Queen making the call to inaugurate STD

bering; each customer had a unique number, which included both the exchange STD code and the individual number on that exchange. The exchange STD code always began with 0, so the previous use of this digit for calling the operator was changed to the present-day 100.

Initially, the codes were alphanumeric; for example, 0TA4 for Taunton, or 0LE2 for Leeds. For London, Birmingham, Edinburgh, Glasgow, Liverpool and Manchester, STD number codes were added as prefixes to the existing alphabetical exchange codes. The alphabetical codes started to disappear when all-figure numbering was introduced in 1966.

With STD came the use of dialled meter units for charging all calls. In addition, coinbox telephones were changed; the old A- and B-button versions were replaced by the pay-on-answer design, which introduced a new sound—the high-speed pips of *paytone*. These, in turn, are now being replaced by electronic press-button prepayment payphones.

Five distance steps had been used for charging trunk calls. Initially, these were reduced to 3 and, later, reduced to the present-day 2: up to 56 km and over 56 km.

# TELECOM 83: A Retrospective Look



D. B. WILLSON†

Its sheer size remains the most lasting impression of TELECOM 83, the fourth World Telecommunications Exhibition, held in Geneva from 26 October to 1 November 1983. The new venue near Geneva airport—the *Palais des Expositions*, universally abbreviated to *Palexpo*—was much larger than the old site near the city centre. Many of the major exhibitors' stands were bigger, and more elaborate than those at TELECOM 79; and this certainly applied to the British Pavilion, which had nearly twice the number of exhibitors. The British Pavilion provided the largest and most comprehensive display of British telecommunications equipment ever to be mounted outside the UK.

His Royal Highness The Duke of Kent, Vice Chairman of the British Overseas Trade Board, caught the mood in his speech on British National Day. He said that this strong British presence, in what was also World Communications Year, not only emphasised Britain's industrial commitment to meeting the needs of its customers at home and overseas, but also demonstrated Britain's determination to play its

full part in the communications revolution that was likely to have profound social and economic effects throughout the world. That revolution was very much in evidence in the British Pavilion. It was particularly reflected in the co-ordinated display devoted to digital operation.

Although Britain was by no means the only country to reflect the digital revolution, its display gave what was probably the most extensive coverage of the subject. It seemed to confirm something that has been increasingly observed in the last year or so—that Britain probably has the greatest commitment to a digital future. It was an impressive display, and one that drew sustained interest throughout the period of the exhibition.

Many visitors were particularly taken by the display of picture Prestel, the first anywhere of a terminal operating to the new European picture videotex standard.

The videoconferencing studio, which showed, for the first time outside the UK, the new terminal cabinet based on the 2 Mbit/s digital-compression codec, was another great success. Visitors virtually began to queue to try out this facility when the link to New York was set up on the last 2 days.

British Telecom's (BT's) section of the British Pavilion was always busy. The working model of the BT International (BTI) *Seadog* unmanned submersible proved particularly popular. Equally in demand was the demonstration of the City Business System (CBS). This may have been stimulated in part by the announcement, on the preview day of the show, that the leading American firm of stockbrokers, Merrill Lynch Capital Markets, had decided to re-equip all its dealer positions in the USA with this equipment.

But the CBS deal was not the only business transaction concluded during the week. On British National Day, contracts were signed to supply Malawi with three UXD5 telephone exchanges and associated digital radio links.

BT won 3 awards in the TELECOM 83 Golden Antenna film festival in Geneva: a Silver Antenna for the vocational-

† Corporate Relations Department, British Telecom Headquarters



A view of the British Pavilion at TELECOM 83



Advanced Prestel facilities being demonstrated to The Duke of Kent



Mr. R. S. Aitken, BTI, with the model of BTI's *Seadog*

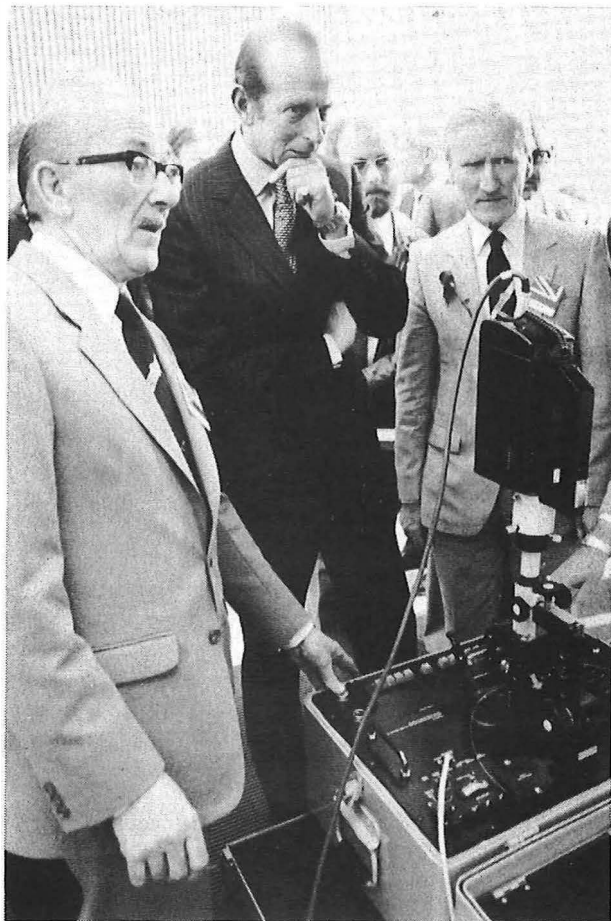

Mr. G. R. Smith, BT Local Communications Services, demonstrating an optical-fibre jointing machine (Jointing Machine No. 101) to The Duke of Kent (centre) and Mr. J. Alvey, Managing Director Development and Procurement and Engineer-in-Chief, BT, in the external exhibition area at TELECOM 83



Under a £2M package deal as part of Britain's contribution to World Communications Year, Malawi is to get three UXD5 digital exchanges, and associated digital radio links, to help improve telecommunications in rural areas. Contracts for the project were signed at TELECOM 83 by (pictured from left to right above) Sir George Jefferson, Chairman of BT; Mr. Richard Reynolds, Managing Director, GEC Telecommunications Ltd.; and Mr. Jasper Mbekeani, Malawi's Postmaster General.

GEC will manufacture, install and commission the exchanges, and provide the digital radio links. British Teleconsult—BT's overseas consultancy service—will provide technical experts to manage the project, advise the Malawi government and supervise network maintenance for the first 2 years of service; it will also train Malawi technicians to run the system subsequently. Most of the cost of the project is being provided by the Department of Trade and Industry and the Overseas Development Administration.

training film *Fibre Optics*; and *Bronze Antennas for Cross Talk*, which shows staff how to handle complaints from customers, and *Desire to Work*, the highly acclaimed film about the disabled and the ways in which telecommunications can help them.

If the design of the British Pavilion lacked the focal point that it had had in 1979—the working System X exchange—it more than made up for this in its cohesiveness, scope and professionalism, even down to kitting out all staff in the same clothing, to reinforce the overall message of British skill, service and competence. This professionalism particularly characterised the stand management staff; their organisation worked smoothly and efficiently despite the inevitable strains imposed on it during the event.

It was notable that the national approach which the British initiated so stunningly 4 years ago had been more widely copied this time around, particularly by some of our European neighbours.

Clearly, TELECOM 87, booked for Geneva from 28 September to 6 October 1987, will demand even more skill and inventiveness from Britain's telecommunications industry if the industry is to maintain its impact in this highly competitive area.



# Martlesham Medal Winners for 1983

BRITISH TELECOM PRESS NOTICE

Roy Harris and John Martin have been awarded the Martlesham Medal for their work in masterminding the design and development of System X for British Telecom (BT). The Martlesham Medal is awarded annually to BT employees, both past and present, who have made an outstanding contribution to science and technology, with particular relevance to telecommunications.

System X has been Britain's biggest development project in telecommunications. It has involved creating virtually from scratch a complete family of telephone exchanges to replace Britain's existing equipment. The bulk of the work has been carried out co-operatively by 4 separate, and very different, organisations: BT, GEC Telecommunications, Plessey Telecommunications and, until October 1982, Standard Telephone and Cables.

Roy Harris and John Martin directed the early stages which were vital to the success of the System X project. Roy Harris originated the concept of using modules—electronic building blocks—as the basis of design; and this has had significant advantages:

(a) it has reduced design and development to manageable proportions, and enabled teams to produce particular modules in acceptable periods of time;

(b) it has allowed exchanges for different applications to be built up from assemblies of modules; and

(c) it has given the system evolutionary potential by enabling advances in technology to be embraced without total redesign of the system being necessary.

John Martin directed and co-ordinated the project. He created the design teams from 1400 staff drawn from the 4 partners, with their very different working methods, and laid down the standards and produced the tools, where none had previously existed, so that the work could be done.

At the presentation in October 1983, Sir George Jefferson, Chairman of BT, noted the appropriateness of Coventry as the venue for the award ceremony because it provided tangible evidence of the winners' achievements. For the city houses the first System X telephone exchange to use a second-generation design of processor; this exchange is one of the most advanced, if not the most advanced, of its kind in the world. After the presentation, Sir George accepted the exchange from its supplier, the Coventry firm of GEC Telecommunications; the exchange has since been opened under the name of *Coventry Spires*.

The successful development and supply of System X is the most significant technical event in BT's recent history. The project is the backbone of Britain's digital modernisation; on it rides all the new services that will help to transform the way in which the country's commercial community organises its daily tasks.

British research into electronic switching dates from the post-war studies that were carried out at the then Post Office Research Station at Dollis Hill. Roy Harris, working with Dr. Tommy Flowers, the first winner of the Martlesham Medal, played a leading role in this work, which led to joint research between BT and British industry in the 1950s.

By the 1960s, Harris and his collaborators in industry had recognised that, as switching systems grew more complex, the cost of their development would become prohibitive. Moreover, as the advance of electronic technology accelerated, the time taken to develop a system would exceed the lifetime of the selected technology. Harris solved the problem by devising modular equipment design, set within an endu-



Roy Harris (left) and John Martin, joint recipients of the Martlesham Medal for 1983 for their work with System X

ring overall system architecture with the functions of the modules, and the interfaces between them, precisely and comprehensively defined. These modules, which he called *subsystems*, could be technically updated when it was convenient and economic to do so without the complete system having to be redesigned.

No single telecommunications organisation in Britain had the manpower resources needed to undertake the development of a replacement telephone-exchange system for the UK. Moreover, although the creation of a monolithic design team may have been possible, the team would have taken decades to complete its task. The modular approach was particularly beneficial, because it simplified software design and reduced the task of debugging, or proving, the software—perhaps its most intractable element—to practicable proportions.

Roy Harris was also one of the first engineers to recognise and advocate that telephone exchanges should be planned as an integral part of the network in which they were placed. This integral-network concept, combined with its digital operation, has provided System X with capabilities that are superior to those of existing systems; and some of these are realised in the range of integrated services that it can provide over the same digital path to the customer.

John Martin, who joined the System X team at the start of collaborative development in the 1970s, provided the

thrust and drive needed to build a design structure and environment from virtually virgin soil.

No development teams skilled in the new software-controlled digital micro-electronic technologies existed in the UK; and so large numbers of young graduates had to be recruited, trained, and set to work. The computer aids to design needed by these newly-formed teams had to be developed and supplied; design tools and test equipment had to be produced. In addition, a common set of design rules and common documentation were needed to ensure that the outputs of all the different teams would slot into place.

Computer-aided design and manufacture were primitive in Britain when the development of System X started. Now Britain is well up in the international league table, thanks in very great measure to the System X project, and to John Martin's inspiration and drive.

He also played a dominant role in creating and imposing discipline over the System X design teams, to ensure that they all stayed within the centrally defined framework; without this the end result would have been chaos. John Martin was the man who pushed designers forward to meet extremely demanding deadlines.

In consequence, the System X project is now coming to fruition ahead of the timetable originally laid down, although it has to be admitted that the acceleration of the programme later hoped for has not been achieved in full. However, Britain is well up in the international ratings in this new sector of telecommunications technology.

### **Roy Harris**

Roy Harris, went to Nottingham High School and Pembroke College, Cambridge University, where he obtained a first-class honours degree in Mechanical Sciences.

He joined the Post Office Research Department in 1947 where, working under Dr. Tommy Flowers, he became one of the first to analyse the fundamental characteristics of telephone switching systems. He devised a number of concepts of time-division switching, now taken for granted by system engineers around the world.

In 1960, he led the team that developed pre-production electronic reed-relay switching systems, the forerunners of the TXE2 and TXE4 designs now widely used in Britain. This work exposed the problem of reconciling change and compatibility, and led him to

propose an evolutionary system based on the concepts underlying System X. These ideas were developed in long-range and research studies started in 1966, and led to the creation of the joint Post Office and Industry Advisory Group on System Definitions; this group, which he chaired, laid the technical foundations for System X.

In April 1974, he became Director, Telecommunications Systems Strategy Department (TSSD), with responsibility for the creation of overall strategy for the future evolution of the telecommunications network and co-ordinated system development. He has continued this work in his present BT post of Director, System Evolution and Standards.

He plays a leading role in national and European forums aimed at harmonising development in telecommunications and information technology; he has written many papers and articles on switching and system strategy, and some 20 patents bear his name. He has been awarded 2 Institution of Electrical Engineers' premiums, was presented with the Institution of Post Office Electrical Engineers' silver medal in 1966, and appointed a Fellow of Engineering in 1967.

### **John Martin**

John Martin joined the British Post Office (BPO) in 1943 as a Youth-In-Training at the Folkestone telephone exchange. After 2 years national service in the Royal Signals Corps, he became an executive engineer in 1955; at the same time, he took a part-time university degree. During this time he helped to prepare the trunk network for the introduction of subscriber trunk dialling in 1958.

In 1963, he became involved in electronic switching as the BPO's liaison officer with Industry for the development of a pre-production prototype of the TXE4 reed-relay electronic exchange system. In 1967, he was given the responsibility for exchange ordering; 2 years later he became head of the design co-ordination branch.

When TSSD was formed in 1974, he was promoted to Deputy Director; thereafter, his main task was liaison with Industry on the development of System X so as to ensure compatibility of design, standards, and documentation.

In 1978, he was appointed Director of a new department that was set up to accelerate the development of System X, which was largely carried out by the staff employed by BT's Industry partners: GEC, Plessey and STC; he acted as the director and co-ordinator of the project. When the System X programme was rationalised in October 1982, STC withdrew and Plessey became the prime contractor for the development of the project.

In May 1983, John Martin left BT to become Director of Engineering at Plessey Telecommunications Ltd.

---

## **Forthcoming Conferences**

Further details can be obtained from the conferences department of the organising body.

**Institution of Electrical Engineers**, Savoy Place, London  
WC2R 0BL.  
Telephone 01-240 1871

**Telecommunications, Radio and Information Technology (Communications 84)**  
16-18 May 1984  
The Birmingham Metropole Hotel

**IFIP Conference on Human-Computer Interaction**  
4-7 September 1984  
Imperial College, London

**Computers in Communication and Control (Eurocon 84)**  
26-28 September 1984  
Brighton

**Online Conferences Ltd.**, Pinner Green House, Ash Hill Drive,  
Pinner, Middlesex HA5 2AE.  
Telephone: 01-868 4466

**Mobile Communications**  
13-15 March 1984  
Barbican Centre, London

**Telecoms Today**  
13-15 March 1984  
Barbican Centre, London

**Satellite Communications**  
13-15 March 1984  
Barbican Centre, London

**Satellite and Cable Television**  
10-12 July 1984  
Wembley Conference Centre, London

**Conference Clearway Ltd.** (United Kingdom Secretariat), Conference House, 9 Pavilion Parade, Brighton, BN2 1RA  
Telephone: (0273) 695811/694079

**Teleconference Symposium**  
3-5 April 1984  
Concurrently in 5 locations: Sydney, Australia; Tokyo, Japan; London, UK; Toronto, Canada; and Philadelphia, USA

# Institution of British Telecommunications Engineers

(formerly Institution of Post Office Electrical Engineers)

General Secretary: Mr. J. Bateman, BT/NS3.2.3, Room 620, Williams National House, 11-13, Holborn Viaduct, London EC1A 2AT; Telephone 01-357 3858.  
(Membership and other local enquiries should be directed to the appropriate Local-Centre Secretary as listed in the October 1983 issue.)

## APPOINTMENT OF NEW PRESIDENT

Mr. R. E. G. Back, Managing Director, National Networks, has been appointed President of the Institution by Council. Mr. Back succeeds Mr. J. S. Whyte, who retired recently.

Ronald Back joined the British Post office in 1942 as a Youth-in-Training at Canterbury. After service in the Royal Signals, he returned to exchange maintenance at Maidstone before moving in 1949 to Headquarters as an Assistant Executive Engineer.

As an Executive Engineer he acted as liaison officer in the construction of deep-level tunnels for cables and equipment. This was followed by a period during which he worked on the design of external plant for radio stations.

On his appointment as a Senior Executive Engineer in 1961, he led a group providing microwave-radio systems; in 1965 he was appointed Assistant Staff Engineer concerned with the provision of satellite earth stations, a task he continued as Head of Division. During this period, the experimental Aerial 1 at Goonhilly was re-equipped for continuous service, Aerial 2 was provided and Aerial 3 construction commenced.

After promotion to Deputy Director in Network Planning Department, he was responsible for transmission planning and the Submarine Cable and Marine Divisions. During this period, these latter divisions undertook the provision of the CANTAT 2 cable and the acquisition by long-term leasing of the new cables, C. S. *Monarch* and C. S. *Iris*.

His move to Service Department came in 1975, initially as Deputy Director and later as Director, a post he held until

July 1979, when he became Senior Director responsible for Networks. This was followed in 1982 by appointment as Assistant Managing Director, National Networks; in this post he was responsible for setting up National Networks as an independent unit dealing with long-distance communications for British Telecom (BT).

In September 1983, he was promoted to Managing Director, National Networks, and in November 1983 appointed to the Board of BT.

## LOCAL-CENTRE SECRETARIES' MEETING

A meeting of Local-Centre Secretaries was held in London on 8 June 1983. The major item that was fully debated was the impact upon IBTE Rules of the introduction by British Telecom of its Management and Professional Structure. The General Secretary undertook to represent the views of the meeting to Council so that appropriate Rule changes could be drafted and put to members.

## FITCE GROUP MEMBERS

Several cases have come to light where members of the FITCE group have not received their copies of the *FITCE Review*. This journal is individually posted, on a quarterly basis, from Brussels direct to the address members have advised. Members are asked to ensure that they inform the Assistant Secretary (FITCE), Mr. P. A. P. Joseph (Telephone: 01-588 8970), of any change of address and if they do not receive a copy.

---

## Notes and Comments

### SYSTEM X REPRINTS

The stock of the book containing reprints of System X articles is now very low. Before sending orders, customers are advised to telephone the Editorial Office on 01-357 4313 to check on the available stock.

### CONTRIBUTIONS TO THE JOURNAL

Contributions to *British Telecommunications Engineering* are always welcome. In particular, the Board of Editors would like to reaffirm its desire to continue to receive contributions from Regions and Areas, and from those Headquarters departments that are traditionally modest about their work.

Anyone who feels that he or she could contribute an article (short or long) of technical, managerial or general interest to engineers in British Telecom and the Post Office is invited to contact the Managing Editor at the address given below. The editors will always be pleased to give advice and try to arrange for help with the preparation of an article, if needed.

### GUIDANCE FOR AUTHORS

Some guiding notes are available to authors to help them

prepare manuscripts of *Journal* articles in a way that will assist in securing uniformity of presentation, simplify the work of the *Journal's* editors, printer and illustrators, and help ensure that authors' wishes are easily interpreted. Any author preparing an article is invited to write to the Managing Editor, at the address given below, to obtain a copy.

All contributions to the *Journal* must be typed, with double spacing between lines, on one side only of each sheet of paper.

As a guide there are about 750 words to a page, allowing for illustrations, and the average length of an article is about 6 pages, although shorter articles are welcome. Contributions should preferably be illustrated with photographs, diagrams or sketches. Each circuit diagram or sketch should be drawn on a separate sheet of paper; neat sketches are all that is required. Photographs should be clear and sharply focused. Prints should preferably be glossy and should be unmounted, any notes or captions being written on a separate sheet of paper. Good colour prints and slides can be accepted for black-and-white reproduction. Negatives are not required.

It is important that approval for publication is given at organisational level 5 (that is, at General Manager/Regional Controller/BTHQ Head of Division level) and authors should seek approval, through supervising officers if appropriate, before submitting manuscripts.

Contributions should be sent to the Managing Editor, *British Telecommunications Engineering*, LCS/P5.1.1. Room 704, Lutyens House, Finsbury Circus, London EC2M 7LY.



# Profiles of Senior Staff

## DEPUTY CHAIRMAN

D. VANDER WEYER, C.B.I.M., F.I.B.



Deryk Vander Weyer joined Barclays Bank in Yorkshire in January 1941, subsequently serving in the Indian Army. He rejoined Barclays in 1947 and his first managerial job was in Liverpool. He became Manager of the Chester branch in 1960, and Local Director responsible for 60 branches on Merseyside in 1964.

In 1968, he started the Bank's first Marketing and Planning Departments as an Assistant General Manager, becoming a General Manager in 1969.

Promoted to Senior General Manager of the Bank in 1973, he was Chairman of the Chief Executive Officers' Committee of the Committee of London Clearing Bankers, and his main preoccupations at that time were in negotiations over the rescue of depositors' money in the fringe banks, called the *lifeboat*, and in re-negotiation of support for such major companies as British Leyland and Chrysler.

In 1977, he became Vice-Chairman, Finance and Planning, for the Barclays Group worldwide, and served on the Diamond Commission. In 1980, he became Chairman of Barclays Bank UK, which manages the high-street branches, Barclaycard and the finance house in the Group, and a Group Deputy Chairman. In addition to committee membership of the Confederation of British Industry, he joined the Board of British Telecom (BT) as a non-executive Director in October 1981. He was a Director of the English National Opera for 5 years and is a Governor of the Museum of London. He is currently Chairman of the Board of Companions of the British Institute of Management, and from 1979 to 1981 he was President of the Institute of Bankers. He retired from Barclays in September 1983, and joined BT as Deputy Chairman on 3 October 1983. He deputises for Sir George Jefferson in all parts of the business, with particular interest in privatisation and finance, and in business systems.

He is married and has a grown-up son and daughter. He lives in London, and his interests include painting and music.

## MANAGING DIRECTOR DEVELOPMENT AND PROCUREMENT, AND ENGINEER-IN-CHIEF

J. ALVEY, C.B., B.SC.(ENG.), DIP. N.E.C.,  
C.ENG., F.I.E.E.



John Alvey was educated at Reeds School, Cobham, Surrey. He joined the Royal Navy in 1943 as a radio mechanic in the Fleet Air Arm. After the war, he studied engineering at London University, obtaining a first-class honours degree in 1950. He then joined the Royal Navy Scientific Services, his initial posting being to the service's Electronics Research Laboratory at Baldock, where he specialised on the development of microwave valves. In the late-1950s, he spent 2 years studying valve and solid-state development in the United States; he returned to a post with the Components, Valves and Devices Directorate in London.

In 1961, he moved into radar-systems research at the Admiralty Surface Weapons Establishment, Portsmouth, with a break

in 1966 to attend the Senior Officers War Course at Greenwich, London. He was appointed Head of Weapons Projects in 1968, with responsibility for the development of naval missile systems such as *Seadart* and *Seawolf*. In 1972, he moved to London as Director General, Airborne Electronic Systems, with responsibility for the development and production of guided weapons, radars and communication equipment for military aircraft. He was appointed Director, Admiralty Surface Weapons Establishment, Portsmouth, in January 1976.

In 1977, he became Chief Scientist to the Royal Air Force and a member of the Air Force Board, being responsible for analytical studies and scientific advice on operational, supply and logistic, and personnel matters. At the same time, he was Deputy Controller Research and Development Establishments and Research in the C Sector with responsibility for research programmes in the aerospace field, including headquarters responsibilities for the management of the Royal Aircraft Establishment, National Gas Turbine Establishment and experimental flying out of Boscombe Down.

He joined British Telecom (BT) in 1980 as Senior Director of Technology with responsibility for the development of future technology relevant to telecommunications and for the BT Research Laboratories at Martlesham Heath.

In 1982, the Minister for Information Technology, Mr. Kenneth Baker, appointed Mr. Alvey as chairman of a committee charged with exploring ways in which Britain could maintain its competitive position in the challenging era of information technology, with particular emphasis on the next generation of computers. The Alvey Report recommended a 5-year programme to mobilise the UK's technical strengths through a Government-backed collaborative effort between industry, the academic sector and other research organisations.

He was appointed Managing Director Development and Procurement and Engineer-in-Chief of BT on 1 August 1983, and is an Executive Board Member.

He is married, has 3 sons and lives in Guildford, Surrey.

## DIRECTOR: LOCAL EXCHANGE SERVICES

P. B. FRAME C.ENG., F.I.E.E.

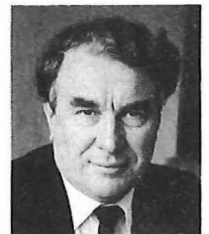

Brian Frame joined the British Post Office as a Youth-in-Training in the Circuit Laboratory in 1947. In the 1950s, he worked in the team developing subscriber trunk dialling and the transit network and afterwards spent some years in the development of analogue and digital switching and signalling systems. This was followed by a spell in the Personnel Department as a member of the Engineering Promotion Board before he took charge of the development of customer apparatus and coinbox equipment in the Development Department. In 1975, he was appointed Head of the New Exchange Systems Development Division with responsibility for developing national and international switching and signalling systems, and in 1980, as Deputy Director in the Exchange Systems Department, he added maintenance and planning for switching systems to his responsibilities. As Director of Local Exchange Services, he is heavily involved in the modernisation of the local exchange switching systems.

Mr. Frame is currently a member of the Board of Editors of the *Journal*.

# British Telecom Press Notices

## CITY BUSINESS SYSTEM IN THE USA

Merrill Lynch Capital Markets, the leading firm of Wall Street brokers, is to replace its present trading equipment with orders worth in excess of \$14M (about £10M) for the City Business System (CBS), designed by the City Telephone Area of British Telecom (BT) London. A joint venture between Centel Corporation and BT to market and distribute the system throughout the USA has also been announced.

The unique CBS provides a single terminal that combines a comprehensive telephone system, data retrieval, computer access and Telex all at the touch of a finger on a monitor surface.

The sale is a major boost to BT exports. BT has produced a world beater; the CBS is flexible, fast and reliable, it saves time and money, and it is easily customised for the large trading establishments of North America. The sale of the CBS to a renowned firm that operates in Wall Street and other financial centres in the USA reflects great credit on BT's team in the City of London.

It is expected that more sales will be achieved by the joint venture with Centel Business Systems, part of the Centel Corporation. Centel Business Systems runs one of the largest activities for marketing business communication systems in the USA. BT has the technical knowledge and a successful company that will enable it to put the product quickly and profitably into a prime market. BT is well ahead of the rest of the world and is confident that it can compete with any rival systems that come on the market in the future.

A CBS terminal consists of a visual display unit (VDU) and 2 telephone handsets. The terminal can be used by dealers for consulting company information, and for sending and receiving Telex messages. Built-in 'hot lines' provide an instant link with other dealers or clients, as well as normal telephone calls. The system stores up to 10 000 pages of information, and can be used to access information on third-party computers.

All operations are controlled by fingertip touch of labelled 'keys', which appear on the VDU. The action of touching these keys is detected by means of an invisible grid of infra-red beams over the surface of the screen.

Up to 10 000 exchange lines, switchboard extensions or private lines can be connected to the system, and it can cater for more than 1000 dealer positions. At a touch of the screen, users can make internal or external telephone calls, hold and release them, and designate a line as PRIVATE.



Sir George Jefferson, Chairman of British Telecom, pictured with a City Business System terminal at TELECOM 83

Although designed for the financial community, the CBS can be used wherever users need access to sophisticated communications without using up desk space. CBS terminals are being used, for example, in the control centre for British Caledonian Airways' activities at Gatwick Airport. The system has been sold in Europe, the Middle East and Hong Kong, where, among other things, it will be controlling a large network of power generating stations for the China Light and Power Company.

The CBS was featured in 2 articles in the October 1983 issue of the *Journal: British Telecom Teletrade* by G. R. Price and *The City Business System* by D. J. French.

## FIRST SINGLEMODE OPTICAL-FIBRE SYSTEM

British Telecom (BT) has successfully tested the world's first 140 Mbit/s commercial optical-fibre link using a technique known as *singlemode transmission*. The link, which is 27 km in length, runs between Luton and Milton Keynes and has no intermediate regenerators.

In general, singlemode systems can span distances of at least 30 km without regenerators having to be used; this is in contrast to the less-advanced multimode systems, in which regenerators have to be installed, usually in manholes, at 6–10 km intervals.

The link between Luton and Milton Keynes was supplied to BT National Networks by Standard Telephones and Cables plc (STC). Its installation was completed in 38 days, from the start of cable laying to acceptance testing. An STC 8-fibre cable, of which 4 fibres are initially being used, has been installed to support two 140 Mbit/s systems. Each can carry nearly 2000 telephone calls simultaneously, or 2 colour television pictures; each is laser driven and operates at an optical wavelength of 1300 nm. Each fibre is 25  $\mu\text{m}$  in diameter, and has a light carrying core of only 8  $\mu\text{m}$ . When successive lengths of fibre are jointed, the butt ends must be accurately aligned to avoid excessive loss.

The cable was supplied in 1 km lengths, and pulled into ducts and jointed by staff of BT's Bedford Telephone Area using an arc-fusion jointing machine designed by BT; this is micropro-

cessor controlled and can achieve an alignment accuracy of 0.25  $\mu\text{m}$ . A BT-designed cleaving tool was used to prepare the ends of fibre for jointing. Even when working alongside a busy trunk road, BT's engineers have been able to achieve high accuracy—the average joint loss has been no more than 0.3 dB.

The installation of this new link confirms BT's position as a world leader in optical-fibre cable technology, and its employment in all of BT's long-distance cable links in the future will bring significant savings in capital and operating costs. Singlemode transmission makes it possible to house the associated electronic equipment in BT's existing buildings, which makes it easy to install and maintain and, protected from the elements, eliminates the problem and expense of manhole access to equipment.

Optical-fibre links form part of the high-capacity digital network being set up in Britain under BT's £1.5 billion a year modernisation programme. Digital transmission reduces costs, gives high-quality speech and, more important, increases flexibility in the way that the network can be used. It paves the way for BT to introduce advanced services such as video-conferencing, high-speed data and high-definition facsimile. In a digital network, these, together with speech, can be sent in comparative ease on the same systems.

# British Telecom Press Notices

## TAT 8

A new transatlantic submarine cable made of optical fibre is to be laid between the USA and Great Britain, currently the world's busiest telephone route. The new cable—code named *TAT 8*—will cater for the rapid growth in telephone calls that has taken place in the past and that will continue in the future. At present, about 30 million telephone calls, equally divided between cable and satellite, are made between the UK and the USA, and it is expected that this figure will at least double during the remainder of this decade.

The new cable will cost approximately £225M, will carry data and messages besides telephone calls and will be completed sometime around 1988. British Telecom (BT) will contribute the second largest share of the cost of its provision, estimated to be £34M.

A unique international arrangement has allowed all 3 companies that tendered—Standard Telephones and Cables plc., AT&T and the French firm of Submarcom—to participate in the 6657 km long project. The cable will be the world's first submarine link to use a junction box on the ocean floor to enable the cable to be landed in 3 countries.

AT&T Communications will supply the 5800 km segment from Tuckerton, New Jersey, to the junction box, which is to be located just off the European continental shelf. STC will

make the 520 km segment from the junction box to the landing point, Widemouth Bay in Cornwall, in the UK. Submarcom will be responsible for the 310 km segment from the branching unit to Penmarche, on the coast of Brittany. Finally, AT&T will be responsible for integrating the 3 systems.

TAT 8 will have 2 pairs of fibres; each pair will operate digitally at 280 Mbit/s, the 2 pairs together being equivalent to nearly 8000 simultaneous telephone calls. The basic capacity of 8000 telephone channels would then be increased to 40 000 by digital circuit-multiplying equipment. Initially, only a small proportion of this capacity will be used; the remainder will be phased into service as it is needed. Singlemode transmission will be used to give high capacity in conjunction with a long spacing between light regenerators. Regenerators are likely to be installed at 30–55 km on the new cable as compared with the 5 km spacing of repeaters in modern undersea coaxial-cable links.

TAT 8 will be jointly owned by at least 28 telecommunications administrations. On the European side, BT International is a co-owner with 18 other administrations, and its share is the largest of the co-owners. North American ownership will be divided between at least 7 companies, of which AT&T has the largest single share.

---

## INTERNATIONAL DIRECTORY ENQUIRY CENTRE OPENED

British Telecom's (BT's) customers outside London can now speak directly to international directory operators who have 800 overseas directories covering 200 countries available to them. Customers outside London making an international directory enquiry for countries other than those in North America can dial 153 to be directly connected to the new enquiry centre at Irvine, Scotland, which opened on Thursday 6 October 1983.

The new centre, which employs just over 100 staff, represents the latest stage in BT's plans for improving its international directory-enquiry service. Prior to the commissioning of Irvine, international telephone enquiries from customers outside London were undertaken at 3 centres. Approximately 8000 international enquiries are handled each day in the UK.

Previously, customers would have spoken to an international

control centre before they were put through to an international directory-enquiry operator. Now, enquiries are dealt with in most cases by the operator who first accepts the call, and this results in a quicker, more efficient service.

A call-queuing system operates so that all calls are answered in order of arrival. Customers connected with the new centre are not left in silence if the operator has to seek out a number; BT provides soft music while they wait. Customers in London still dial either 102 or 103, depending upon the country they require. For directory enquiries for North America, customers dial 107, 155 or 157, depending on their location. They are then connected to a BT International operator, who obtains the required information from an operator in the USA or Canada.

---

## CARGO NET

A new computer package designed to help freight forwarders has been launched by the National Data Processing Service (NDPS). The package, known as *Cargo Net*, comprises a set of programs and all the necessary computer equipment; for larger installations, it includes a microcomputer designed and built by British Telecom (BT).

Cargo Net is offered as the total solution to air-freight forwarders' office problems. It is a modular package, handling any or all of the following: imports and exports, management information and statistics, job costing and invoices, accounts and ledgers, payroll, word processing and mailing.

According to the agent's scale of operations, Cargo Net can operate either as a small stand-alone system with a single

terminal or as a local area network with up to a dozen or more simultaneous users. Satellite or branch offices can be linked together over normal telephone lines. The core of the smaller systems will be a Videcom microcomputer, which can also double as a terminal for ACP80 and DEPS, the sophisticated air-cargo-handling and customs-processing services which are also operated by NDPS. This will make it particularly attractive to small businesses which up to now have shared another trader's ACP80 terminal.

Larger systems will be provided with a microcomputer purpose-designed and built by BT. In both cases a comprehensive selection of programs is supplied, plus a correspondence quality daisywheel printer.

# British Telecom Press Notices

## MERLIN INTRODUCES NEW RANGE OF SMALL BUSINESS COMPUTERS

Merlin, British Telecom's (BT's) business equipment supplier, launched, in October 1983, a new range of small business computers to mark the nationwide availability of its office automation products. Full UK introduction of BT's office automation equipment was achieved just 6 months after its initial unveiling in London.

During this period a basic network of district offices was set up around the country, and these will be progressively enlarged in the future. Merlin is creating more than 100 jobs by setting up a specialised sales team, which will be supported by fast-acting service back-up for its customers, in both hardware and software.

This has been accomplished in addition to Merlin increasing its established business in office switchboards and call-connect systems, data modems and teleprinters. And with other developments in information technology waiting on the sidelines—*Chain* for the health service and *Modulus* for the travel industry—Merlin has clearly become a competitive force where the electronic office is concerned.

Merlin's commitment to office automation is based, first and foremost, on customer care, in the widest sense; it is not just offering hardware but providing a comprehensive service. Merlin wants customers to be confident that any equipment they buy will work, and that full training of operators, service back-up, updates and enhancements will be provided. Customers who become involved in office automation with Merlin will not be leaping in the dark. Although they will be entering a new world, it will have familiar landmarks, and everyday language; they will not have to learn the language of computer jargon. Merlin has done everything possible to ensure that users get the most

from the equipment.

The principal addition to the range of automated-office equipment is a business computer with a significantly smaller memory store than the existing machine. Known as the *M2215*, this computer has an integral memory of 64 Kbytes and a twin floppy-disc drive. This compares to the 5 Mbyte hard-disc drive and one floppy-disc drive of the existing *M2226*. Both computers feature a wide range of communications options that enable access to private and public databases to be achieved automatically at the touch of a button. Machines can send and receive messages by using a computer-based message service such as *Telecom Gold*; linked to a Puma teleprinter, the computers become Telex terminals. They also employ the unique Merlin-Master interface software, which guides the operator through each computer application. This is offered with a wide range of applications software packages, including sales co-ordination, mailing list, business administration and financial modelling; also, the *WordStar* word-processing package. A choice of printers is available: a daisy-wheel printer for correspondence, and 2 sizes of dot-matrix units.

Complementing the 2 computers is the *M1100* desk-top visual display unit, which uses the same modem as the business computers. The terminal can link into computer service bureaux, *Prestel*, *Telecom Gold* and the *Packet SwitchStream* data service.

Merlin's current range of automated-office equipment is completed by the *M3300* communication word processor, which offers the option of press-button access to the Telex network, via a Puma teleprinter, and automatic dial-up to remote databases, computer bureaux, *Prestel* and electronic-mail services.

## OPTICAL-FIBRE NETWORK FOR CENTRAL LONDON AND DOCKLAND

British Telecom's (BT's) plans to provide central London and its dockland with a comprehensive optical-fibre network was unveiled last October by Sir George Jefferson, Chairman of BT. The new network, in which an initial investment of more than £2M has been made, will make it possible to provide businesses with high-technology communications virtually off the shelf.

In the future, BT's business customers will be able to see as well as speak to each other. This dramatic step forward follows the introduction in 1981 of London's highly successful overlay communications. This has enabled BT to provide private business links very quickly, in some cases within 24 hours.

BT is once again helping to attract world business to London by providing the advanced interactive services sought by modern companies. The broadband network will, by adding the vital extra dimension of vision, such as closed-circuit television, or videoconferencing, enable BT to transform voice communications.

London will become one of the world's first major cities to have an advanced interactive network of this kind; it will put the capital at the forefront of modern communications and reinforce its excellence as a world communications centre. In addition to visual services, this network will be able to offer enhanced *Prestel* facilities, high-speed computer-to-computer data transfer, high-resolution facsimile and interconnection of local area networks. It will also provide for all standard business services, such as data, text and speech, and cater for the high capacity X-Stream digital services offered by BT.

Work has already started on the project, in which ultimately 150 km of optical-fibre cable will be used to link strategic locations in London's central area. The first phase serving inner London will cover Dockland, the City, Westminster and much of the West End, and the aim is to complete the work by September of this year. The network will operate at 140 Mbit/s,

to offer customers a much wider range of speeds than those currently available.

The inclusion of London's dockland in the project underlines BT's recognition of the emerging importance of this development area. Taking the optical-fibre network to Wapping, Poplar and the Albert Dock area represents only part of BT's investment plans for Dockland. Plans have already been announced for the construction of a satellite earth station there; and BT intends to install digital switching systems. BT's investment in the area demonstrates its continued commitment to providing London with the first-class communications facilities which will effectively make Dockland an integral part of the City's business community.

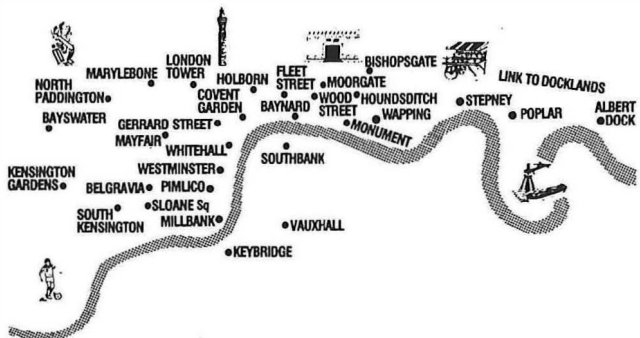

Locations to be covered by BT's 'Heart of London' optical-fibre network



# British Telecommunications Engineering

Those wishing to subscribe to *British Telecommunications Engineering* can do so by completing the relevant section of the order form below. British Telecom (BT) and British Post Office (BPO) staff should complete the upper section and send it to their local *BTE Journal* agent or, in case of doubts, to the address shown; other subscribers should complete the lower section. A photocopy of this form is acceptable.

## SUBSCRIPTION ORDER (BT and BPO STAFF)

To: The Local Agent (*BTE Journal*), or  
*British Telecommunications Engineering Journal*  
(Sales), Post Room,  
2-12 Gresham Street, London EC2V 7AG.

### British Telecommunications Engineering: Authority for Deduction from Pay

Please arrange for me to receive *British Telecommunications Engineering*. I have completed the form opposite authorising deductions from pay to cover the special annual subscription of £1.92.

I .....  
(name in full, surname first in block capitals), authorise the deduction from my salary or wages, until further notice, of the sum of 16p per month/4p per week for 48 weeks for payment to the Managing Editor, *British Telecommunications Engineering*, on my behalf.

Date ..... Signature .....

Date ..... Signature .....

Name and initials (in block capitals) .....  
Rank .....

Official address .....

Official address .....

Rank ..... Pay No. ....

Area/Dept. ....

## YEARLY SUBSCRIPTION ORDER (NON-BT/BPO STAFF)

To: *British Telecommunications Engineering Journal*  
(Sales), Post Room,  
2-12 Gresham Street, London EC2V 7AG.

Name .....

Address .....

Please supply 4 quarterly issues of *British Telecommunications Engineering*. I enclose a cheque/postal order for the sum of £5.60 (Canada and the USA: \$12) to cover the yearly subscription.

.....

.....

(Cheques and postal orders, payable to "BTE Journal", should be crossed "& Co." and enclosed with the order. Cash should not be sent through the post.)

Please state with which issue you wish your subscription to commence (April, July, October or January) .....

## IBTE CENTRAL LIBRARY

Any member who does not have a copy of the catalogue can obtain one on loan from the Librarian, IBTE, 2-12 Gresham Street, London EC2V 7AG. Library requisition forms are also available from the Librarian, from honorary local-centre secretaries, and from Associate Section centre secretaries and representatives.

Alternatively, the panel opposite, or a photocopy, can be used (only by members) to borrow any book listed in the catalogue or in the updating lists published in recent issues of the *Journal*. The form should be sent to the Librarian at the address above; a self addressed label must be enclosed.

### IBTE Central Library LIBRARY REQUISITION FORM

*For use only by members of the Institution of British  
Telecommunications Engineers*

Author .....

Title .....

.....

Catalogue No. .... Date .....

Name .....

Official Address .....

## INDEX TO ADVERTISERS

### Advertisements

Communications should be addressed as shown below.

*No responsibility is accepted by the Journal for any of the private or trade advertisements included in this publication.*

John Noad (Ceilings) Ltd. . . . .	7
Eaton-Williams Products Ltd. . . . .	12
EXACT . . . . .	6
Fischbach Ventilation Ltd. . . . .	7
GEC Telecommunications Ltd. . . . .	8
Greenpar Connectors Ltd. . . . .	13
Herman Smith (Eurocraft) Ltd. . . . .	14
Intertec Electronics Ltd. . . . .	9
Krone (UK) Technique Ltd. . . . .	4
Plessey Telecommunications Ltd. . . . .	2
Siemens Ltd. . . . .	10
STC Telecommunications Ltd. . . . .	5
Teradyne Ltd. . . . .	1
Ultra Electronic Components Ltd. . . . .	9

# British Telecommunications Engineering

### Copyright

The entire contents of this *Journal* are covered by general copyright, and special permission is necessary for reprinting long extracts, but editors are welcome to use not more than one-third of any article, provided that credit is given at the beginning or end, thus: 'From *British Telecommunications Engineering*'.

The Board of Editors is not responsible for the statements made nor the opinions expressed in any of the articles or correspondence in this *Journal*, unless any such statement is made specifically by the Board.

### Subscriptions and Back Numbers

The *Journal* is published quarterly in April, July, October and January, at 90p per copy (£1.40 per copy including postage and packaging); annual subscription: £5.60; Canada and the USA: \$12.00.

The price to British Telecom and British Post Office staff is 48p per copy.

Back numbers will be supplied if available, price 90p (£1.40 including postage and packaging). At present, copies are available of all issues from April 1974 to date with the exception of the April and October 1975; January, April and October 1976; and January 1982 issues.

Orders, by post only, should be addressed to *British Telecommunications Engineering Journal*, 2-12 Gresham Street, London EC2V 7AG.

Employees of British Telecom and the British Post Office can obtain the *Journal* through local agents.

### Binding

Readers can have their copies bound at a cost of £8.75, including return postage, by sending the complete set of parts, with a remittance, to Press Binders Ltd., 4 Iliffe Yard, London SE17 3QA.

### Remittances

Remittances for all items (except binding) should be made payable to '*BTE Journal*' and should be crossed '& Co.'

European customers can pay by means of a direct bank mail transfer. Customers using this method of payment should instruct their bankers to remit payments to the *Journal's* bankers—Midland Bank plc, 2 Gresham Street, London, EC2V 7JD, England—specifying that the beneficiary is to be *British Telecommunications Engineering Journal*.

### Distribution and Sales

Correspondence relating to the distribution and sales of the *Journal* should be addressed to *British Telecommunications Engineering Journal* (Sales), Post Room, 2-12 Gresham Street, London EC2V 7AG.

### Communications

With the exceptions indicated, all communications should be addressed to the Editorial Office, *British Telecommunications Engineering*, LCS/P5.1.1, Room 704, Lutyens House, Finsbury Circus, London EC2M 7LY (Telephone: 01-357 4313).

### Advertisements

All enquiries relating to advertisement space reservations should be addressed to Mr. A. J. Pritchard, The Advertisement Manager, *British Telecommunications Engineering Journal*, Room 608, 2-12 Gresham Street, London EC2V 7AG.

### Model-Answer Books

Books of model answers to certain of the City and Guilds of London Institute examinations in telecommunications are published by the Board of Editors. Copies of the syllabi and question papers are not sold by *British Telecommunications Engineering Journal*, but may be purchased from the Sales Department, City and Guilds of London Institute, 76 Portland Place, London W1N 4AA.

# When you've been finding faults as long as we have, it's easy to knock the competition.

STC first set out to design a new system of remote line testing equipment back in 1977.

The results attracted worldwide interest and praise.

Not least from British Telecom who worked closely

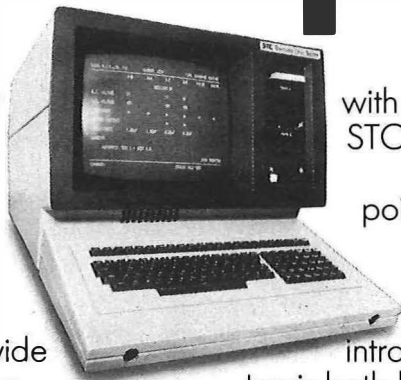

with us to develop the STC RLT II.

Its ability to pinpoint faults at any distance from the Repair Service Centre led to its introduction on a trial basis both here and abroad.

Today, the RLT II is tried, tested and already operating

in several centres throughout the U.K.

We're sorry to say our competitors are a little behind. But who's fault is that?

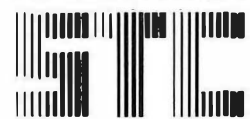

RLT II Remote Line Tester

FOR FURTHER INFORMATION PLEASE CONTACT A E REDHEAD, STC TELECOMMUNICATIONS LTD.,  
INFORMATION TERMINALS DIVISION, OAKLEIGH ROAD SOUTH, NEW SOUTHGATE, LONDON N11 1HB. TEL: 01-368 1234



# exact

## An International Scheme for the Exchange of Authenticated Data on Electronic Components

*EXACT is a technical association which provides users of electronic components with test, reliability and performance data on components and related materials from worldwide sources. The prime aim of the scheme is to enhance the knowledge of equipment manufacturers regarding the performance of electronic components and to reduce costs by avoiding duplication of testing.*

- Companies within the scheme provide EXACT with test reports generated by their own procedures and these are then circulated to the other members.
- Easy access to the data from EXACT Indexes.
- A very wide range of components is covered including LSI, capacitors, resistors, connectors, relays, etc.
- Reports are written in English or with an English translation.
- 83 Members in 15 countries.
- Members in the UK include British Telecom, STC and Plessey.

*For further details of the EXACT Scheme contact:*

The General Secretary, EXACT,  
EXACT Central Office, Burroughs House,  
The Burroughs, London NW4 4AP. Tel: 01-202 0937



# Little & Large and all the stages in between

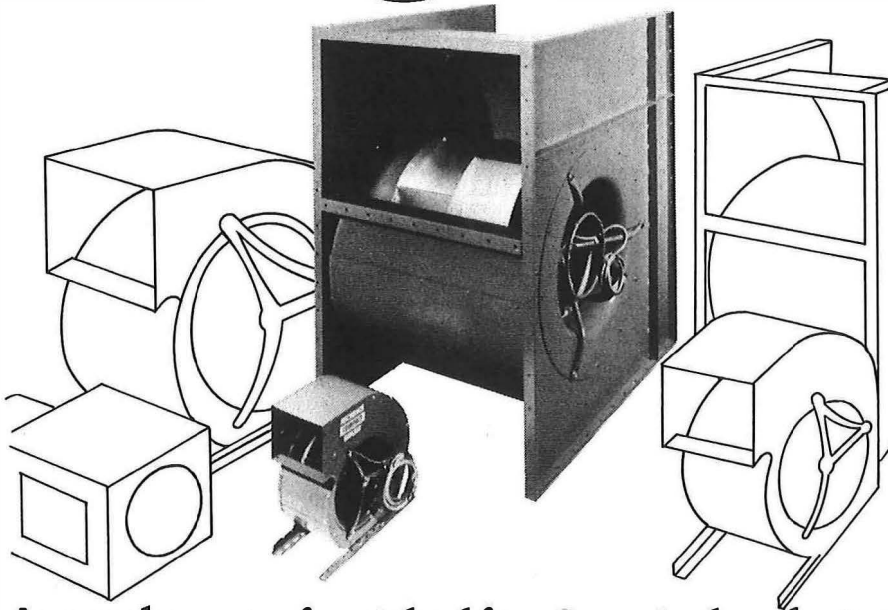

**A superbrange of matched fan & control packages available 'off the shelf.' From Fischbach. Who else?**

Our superb centrifugal fan range now extends all the way up to 10m<sup>3</sup>/s. All units feature Fischbach Disc Rotor fully protected, induction motors for low cost, ultra quiet, high efficiency performance.

But use of this special motor design means much, much more. Coupled with our range of manual and automatic speed controllers it enables us to offer complete matched packages to meet virtually any specification including VAV controlled by pressure, temperature or humidity.

We hold stocks too! So even specialised requirements can very often be met literally 'off-the-shelf' at very competitive prices.

Why make life complicated? The Fischbach solution is *only a phone call away!*

**FISCHBACH  
VENTILATION**

**Fischbach Ventilation Ltd.,**  
9, Jefferson Way, Thame Industrial Estate,  
Thame, Oxon, OX9 3SY  
Tel: 084 421 5611 (4 lines) Telex: 837734

## British Telecom Cool it with JNLX

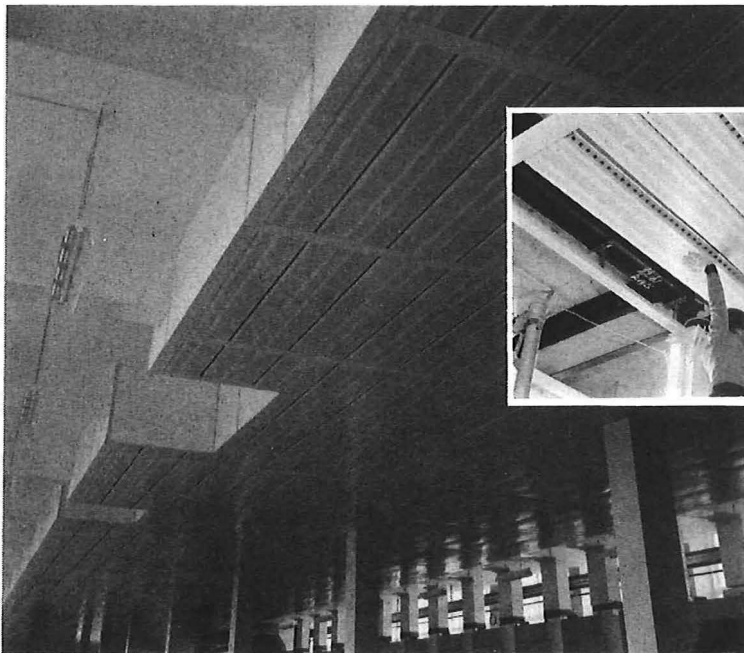

The JNLX all steel integrated ceiling system from John Noad (ceilings) Limited was developed in conjunction with British Telecom for cooling System X, and there are now numerous installations proving the efficiency of the system.

Its exclusive design combines the advantages of high quality materials and short programme times, with high cooling capacity and versatility of installation — utilising the tried and proven JNL air supply slots.

JNLX is also available with lighting fittings (modular or linear), and the steel trays are available in a wide range of durable electrostatically applied zinc powder colour finishes to complement the working environment.

**FOR MORE DETAILS CONTACT:**

**JNL** JOHN NOAD  
(ceilings) LTD

218 New Road, ASCOT, Berks SL5 8PT. Tel. No. Winkfield Row (0344) 884831 & 882070.

# Good Morning

It's the dawn of the digital 80's from GEC Telecommunications. Now with a total network capability in digital transmission systems up to 140 Mbit/s; microwave radio systems, coaxial-cable and optical-fibre line systems and a complete range of digital multiplex.

Versatile business communications systems, including P.A.B.X.'s from 4 to over 5,000 lines using digital switching and stored programme control.

The dawn of digital technology from GEC Telecommunications... make an early start.

## **GEC**

Telecommunications

GEC Telecommunications Limited,  
P.O. Box 53, Coventry CV3 1HJ England.

A Management Company of  
The General Electric Company p.Lc., of England. CC 24

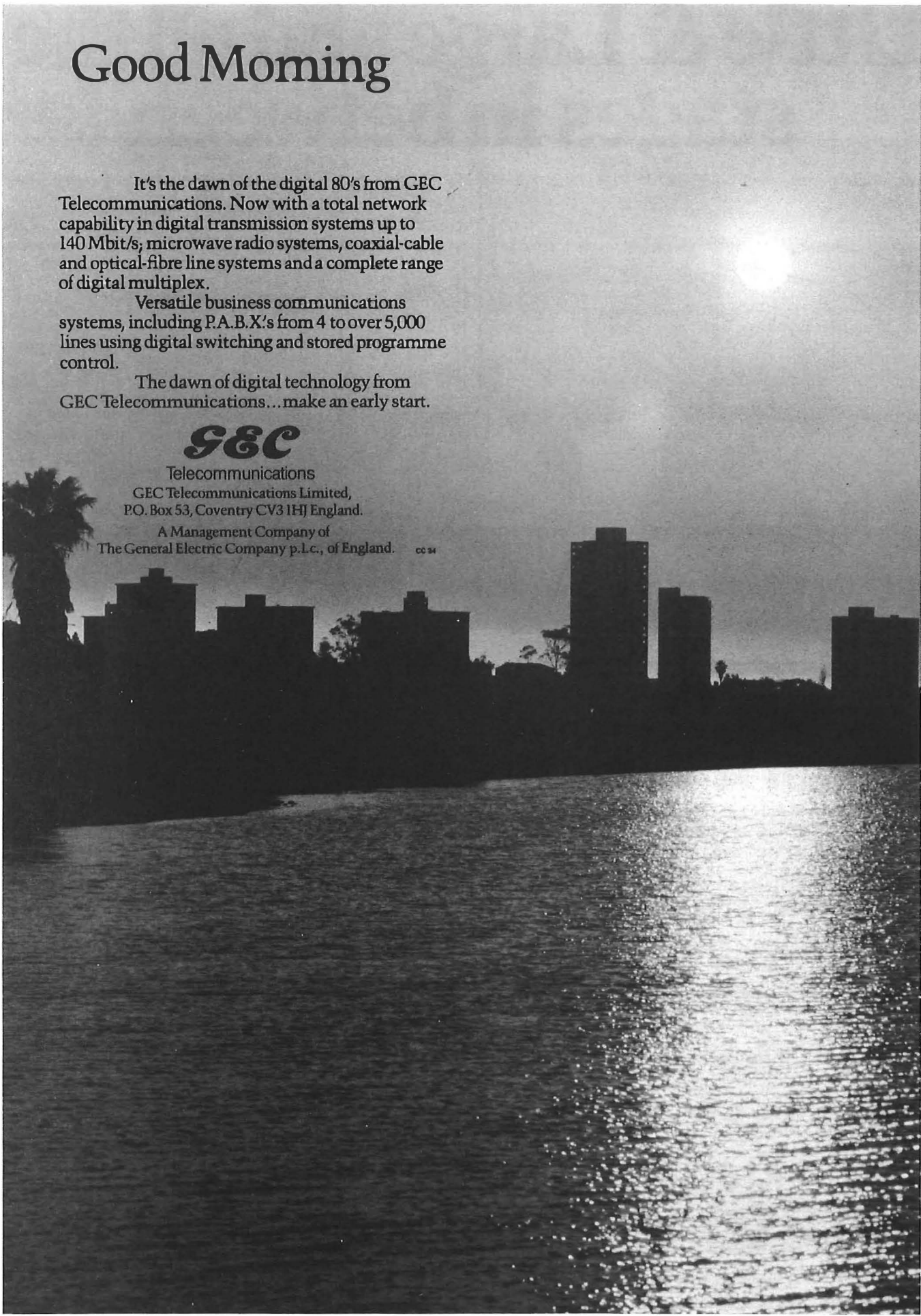

# A NEW GOLDEN AGE OF CONNECTORS

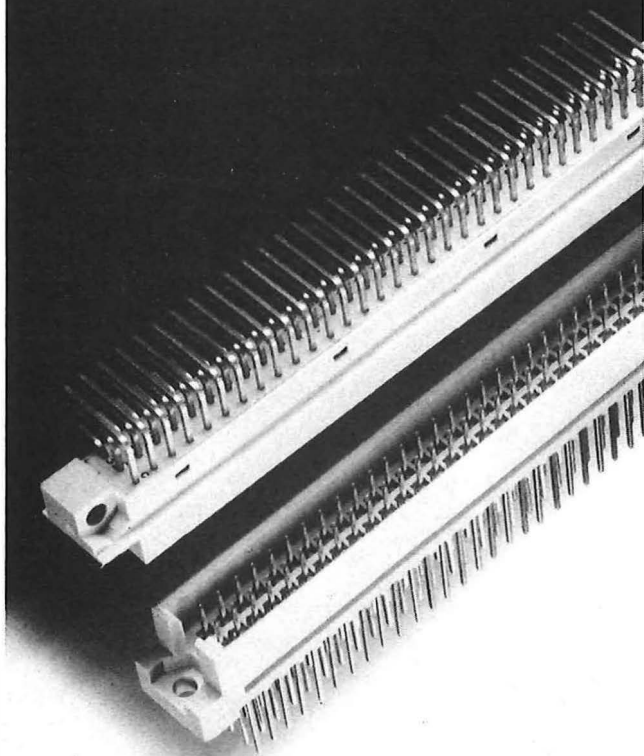

## UECL satisfy a need with reversed indirect printed circuit connectors ex-stock

- ★ Connectors conform to BS 9525 F0017 and DIN 41612.
- ★ Inlaid gold contacts economise on, and stabilise costs yet improve performance. Connectors have the most enduring mechanical efficiency.
- ★ Connectors are entirely designed and manufactured in the UK by UECL. Automated production techniques keep prices down and facilitate delivery.
- ★ The full range of terminals is available ex-stock from us and five UK stockists.

Ask today for our brochure on Series 1696 Reversed Types Q, R and T.

## Ultra Electronic Components Ltd

Fassetts Road, Loudwater, High Wycombe, Bucks. HP10 9UT  
Tel: High Wycombe (0494) 26233 Telex: 83173

### DIN STOCKISTS

**Ajax Electronics Ltd.**, Ajax Avenue, Slough, Berks. 0753-76331

**Component Technology Ltd.**, Eastington Trading Estate, Nr. Stonehouse, Gloucester. 045382-5281

**Electronics 2000 Ltd.**, 94 Kitchener Road, High Wycombe, Bucks. 0494-451567

**Intercontinental Components Ltd.**, Clivemont Road, Cordwallis Trading Estate, Maidenhead, Berks. 0628-32466

**Vako Electronics Ltd.**, Pass Street, Oldham, Gt. Manchester. 061-652-5111

Ultra-connectability



# Communicating?

... INTERTEC ELECTRONICS SUPPLY  
A WIDE RANGE OF SPECIALISED EQUIPMENT  
FOR THE COMMUNICATIONS INDUSTRY

## INTERTEC

Facsimile and Radio Modem Equipment including:

Model GD 396 Variable Shift Demodulator (F1) - IEEE 488 Interface.

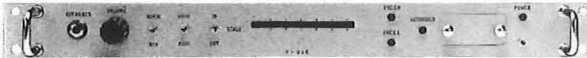

Model F226 FM/AM Facsimile Demodulator.

Model K326 AM/FM Facsimile Modulator.

Model GD 496 Variable Shift DFSK (F6) Demodulator - IEEE Interface.



GD496

Sole UK Distributors for:

**PLANTRONICS Wilcom**  
Telecommunications Test  
Equipment including:

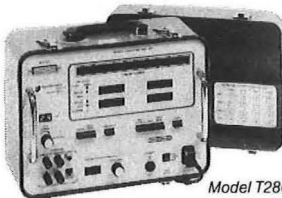

Model T286

Model T286 DTMF Test Set for evaluating performance of dual tone multifrequency (DTMF) tone systems and equipment.

Model T306E Phasor Impedance Measuring Set measures both resistive and reactive components of impedance ( $R \pm jX$ ) at frequencies between 20Hz and 20kHz.

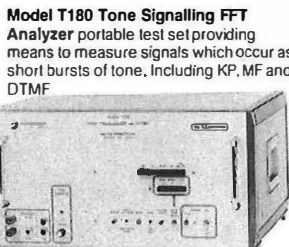

Model T180

Model T180 Tone Signalling FFT Analyzer portable test set providing means to measure signals which occur as short bursts of tone, including KP, MF and DTMF



Model T306E

Model T296 Programmable Frequency Synthesizer portable signal generator capable of simultaneously sending two tones between 20Hz and 20kHz. The frequency, level, pulsing on and off times of each tone are controlled by a microprocessor.



Model T296

Model T222C Signaling Test Set provides facilities for accurately measuring the performance of DC and SF signaling systems. Both send and receive functions measured.

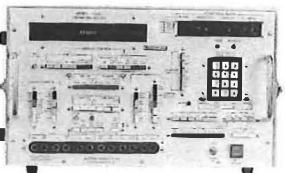

Model T222C

**PLANTRONICS Frederick Electronics**  
Specialised FSK Modems including:

Model 1635 Variable FSK/DFSK Demodulator operates as a four channel FSK or two channel DFSK demodulator.

Model 1635-SD Spectrum Display

Model 1636 Digitizer/Multiplexer

The D<sup>3</sup> Frequency and Traffic Monitoring System incorporates all three equipments offering a comprehensive system to

monitor, capture, analyse and quantify traffic without prior information regarding mark or space frequencies, shifts or baud rates.

Model 1277 and 1280 Programmable FSK Modems the latest in a comprehensive range of proven equipment.

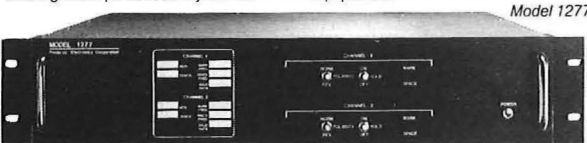

Model 1277

Further information on Intertec, Wilcom and Frederick can be obtained from:

**Intertec Electronics Ltd.**

Unit 3, Brook Road, Wimborne, Dorset BH21 2BH  
Telephone (0202) 881707 Telex 418122

**INTERTEC** (ELECTRONICS) LTD.

# See what a Siemens team can do...



## For British Telecom

One major project involved the design and manufacture of additional high power amplifiers operating at 6GHz with an output power of 8kW. Technologies incorporated include high voltage/high current power supplies, waveguide systems, water and air cooling systems and a sophisticated, microprocessor-based, supervisory system. Associated equipment includes ALC systems and a control system. Projects in this field have also been carried out for the German and Dutch PTT's.



## For the Royal Navy

A teleprinter interface unit has been developed for MOD (N). This ruggedised modem, for ship and shore based use with Siemens T1000 Teleprinter, has since been produced in volume. Other projects include peripheral equipment such as a magnetic cassette recorder, to reduce the need for papertape, and a free-standing paper tape reader for satellite circuits. The development and manufacturing facilities of Siemens Limited in Congleton have been successfully assessed to Defence Standard 05-21 and BS 5750.



## For the DOI

Seaview was a sequence of projects partly financed by the DOI as part of Information Technology Year '82. The projects, carried out jointly with CAP and with the co-operation of Townsend Thoresen and British Telecom International, were to investigate the feasibility of the transmission of Prestel-like information over maritime VHF radio circuits. Successful trials were carried out at sea during 1982.

**Siemens - Electronic systems are our business**



## For You?

The facilities of our Communication Systems Engineering Department cover five broad areas, all fully backed by a manufacturing capability.

### Microprocessor engineering

The department is well equipped with development/emulation facilities, PROM programmers, printers, logic analysers, and software support. A PDP11/44 is also available for software development and documentation.

### Analog/digital design

A wide range of equipment supports our extensive experience of precision analog circuitry, A/D converters, microprocessor control/display interfaces, fibre optic data links, data modems, phased locked frequency generators, digital communication systems, and transducer interface circuits.

### RF and microwave

Experience up to 30GHz, backed by extensive facilities, includes high power amplifier design using single and cascaded travelling wave tubes and precision down converter subsystems for level control.

### Power electronics

Products developed in this field include several high voltage DC power supplies (1-22kV) in various power ratings up to 50kW. Experience also includes precision measurement and control of floating high voltage supplies, UPS systems and static inverters.

### Support facilities

To support all of the above activities, the department is well equipped with a model room, prototype PCB production facilities, CAD for PCB layouts and an extensive microfilm library of all relevant BSI, Defence and CCITT specifications. Use is also made of remote database facilities such as Lockheed Dialog in the USA. Apart from our own immediate resources, we are able to draw on the products and experience of our parent and sister companies in more than 100 countries throughout the world, and 330,000 colleagues, whether it be in the field of transmission, terminal equipment, switching, speech or data, or any other aspect of communications or electronics.



*Hardware/Software integration*

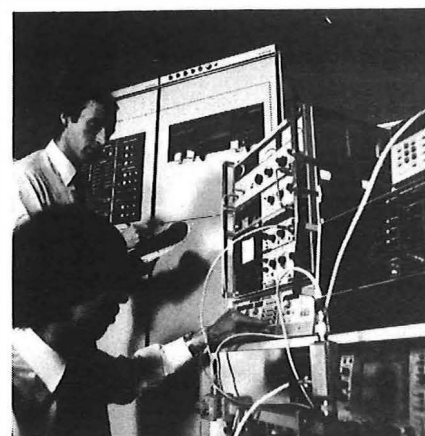

*Test procedures on a high power amplifier*

**Ring now for further information.**

**Contact Roger Killick  
or Mauro Cordani  
on 02602 78311 Ext 185**  
Communication Systems Engineering,  
Siemens Limited, Eaton Bank,  
Congleton, Cheshire CW12 1PH.  
Telex: 8951091 SIELON G



Eaton-Williams Products Ltd.

## Nationally Approved BT 1A/15 kW Cooling Unit

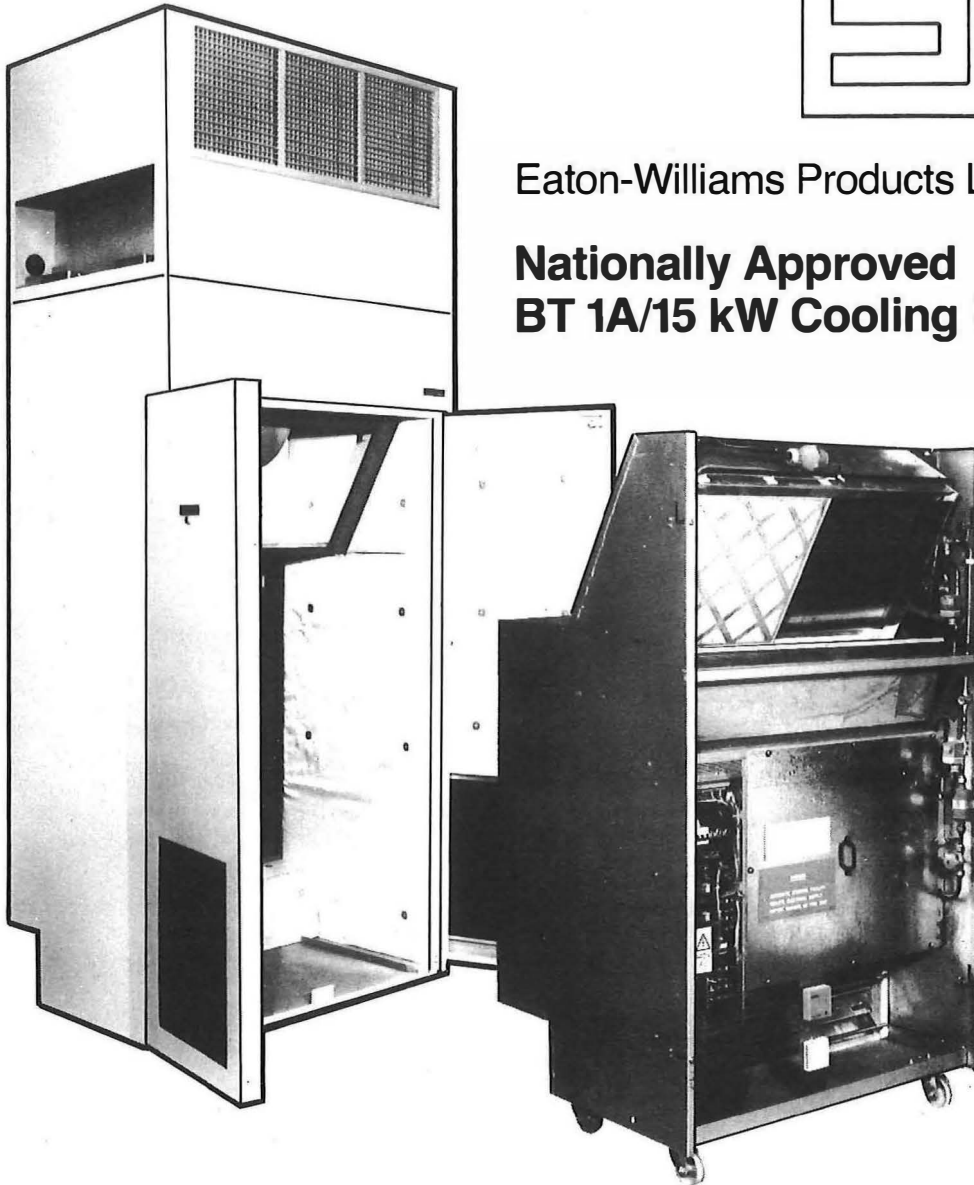

The BT 1A/15 Cooling Unit is a free-standing, self-contained air-conditioning unit, quiet in operation and specifically designed to provide an inherently reliable cooling system for British Telecom System X and TXE 4 telephone exchanges.

Cooling is provided by a direct expansion (DX) close-coupled refrigeration system arranged so that the cooling coil and the air cooled condensers are both contained within the BT 1A/15 unit. The unit is designed for upward airflow with return air from the room entering the unit at low level on the front, through a modulating volume control damper, it then mixes with fresh air drawn in at the rear of the unit. In this way the recirculating air and fresh air ratio can be varied to obtain as much 'free' cooling as possible from the fresh air. Cooling air is supplied to the room at high level.

The unit is designed to provide a sensible cooling capacity of 15 kW with external ambient conditions between the limits  $-7^{\circ}\text{C}$  and  $32^{\circ}\text{C}$ . Reduced cooling capacity available up to  $40^{\circ}\text{C}$ .

The micro-processor control system is designed to maintain the room condition at  $24^{\circ}\text{C} \pm 3^{\circ}\text{C}$  by optimum use of outside fresh air to obtain as much free cooling as possible under suitable outside ambient conditions. This is done by automatic modulation of the fresh and recirculating air volumes with supplementary use of the direct expansion cooling system.

**Eaton-Williams Products Ltd.**  
Station Road, Edenbridge,  
Kent TN8 6EG  
Tel: Edenbridge (0732) 863447  
Telex: 95493

The Greenpar range of 75 ohm BT 43 series connectors is approved to both BT.8003 and BS 9210F0022, certifying conformity of design and providing user confidence in quality, performance and reliability. Cost effective design plus the latest computer test technology ensures complete product integrity whilst continuity and volume supply is assured by our fully automated manufacturing and assembly procedures.

The BT 43 family of connectors comprises the following:

U link, featuring a robust Noryl body designed for ease of use and long life; straight and right angle PB and cable crimp types both designed for ease of assembly and with either snap-on or latching engagement. The latching connector, which prevents accidental disconnection, is preferred for most applications.

#### BT/Greenpar/British Standard cross reference

BT	Greenpar	B.S. Style	Cable
<b>Straight Crimp Sockets</b>			
43/1A	G67241D280	06-03-1B1-C	2001
43/2A	G67241D117	06-03-1B2-Q	2002
43/3A	G67241D62	06-03-1B3-R	2003
43/4A	G67241D22	06-03-1BB-B	RG179B/U

# BT 43 series

#### Straight Latching Crimp Sockets

43/1B	G67243D280	06-03-2B1-C	2001
43/2B	G67243D117	06-03-2B2-Q	2002
43/3B	G67243D62	06-03-2B3-R	2003
43/4B	G67243D22	06-03-2BB-B	RG179B/U

#### Right Angle Latching Crimp Sockets

43/1C	G67244D280	08-03-2B1-C	2001
43/2C	G67244D117	08-03-2B2-Q	2002
43/3C	G67244D62	08-03-2B3-R	2003
43/4C	G67244D22	08-03-2BB-B	RG179B/U

#### Right Angle Crimp Sockets

43/1D	G67242D280	08-03-1B1-C	2001
43/2D	G67242D117	08-03-1B2-Q	2002
43/3D	G67242D62	08-03-1B3-R	2003
43/4D	G67242D22	08-03-1BB-B	RG179B/U

#### Straight Bulkhead Crimp Plugs

43/1A	G67245D280	07-02-1B1-C	2001
43/2A	G67245D117	07-02-1B2-Q	2002
43/3A	G67245D62	07-02-1B3-R	2003
43/4A	G67245D22	07-02-1BB-B	RG179B/U

#### Right Angle Bulkhead Crimp Plugs

43/1B	G67249D280	11-02-B1-C	2001
43/2B	G67249D117	11-02-B2-Q	2002
43/3B	G67249D62	11-02-B3-R	2003
43/4B	G67249D22	11-02-BB-B	RG179B/U

#### Straight 5 mm Bulkhead Mount Plugs

43/1C	G67247D280	07-02-2B1-C	2001
43/2C	G67247D117	07-02-2B2-Q	2002
43/3C	G67247D62	07-02-2B3-R	2003
43/4C	G67247D22	07-02-2BB-B	RG179B/U

#### Straight PCB Mounting Plug

43/1D	G67207	13-02
-------	--------	-------

#### Right Angle PCB Mounting Plug

43/1E	G67210	14-02
-------	--------	-------

#### U Link

13A	G67229	33-05
-----	--------	-------

Greenpar offers a comprehensive range of miniature and r.f. connectors, cables and assemblies and has been an approved BT supplier since 1973.

# set your sights

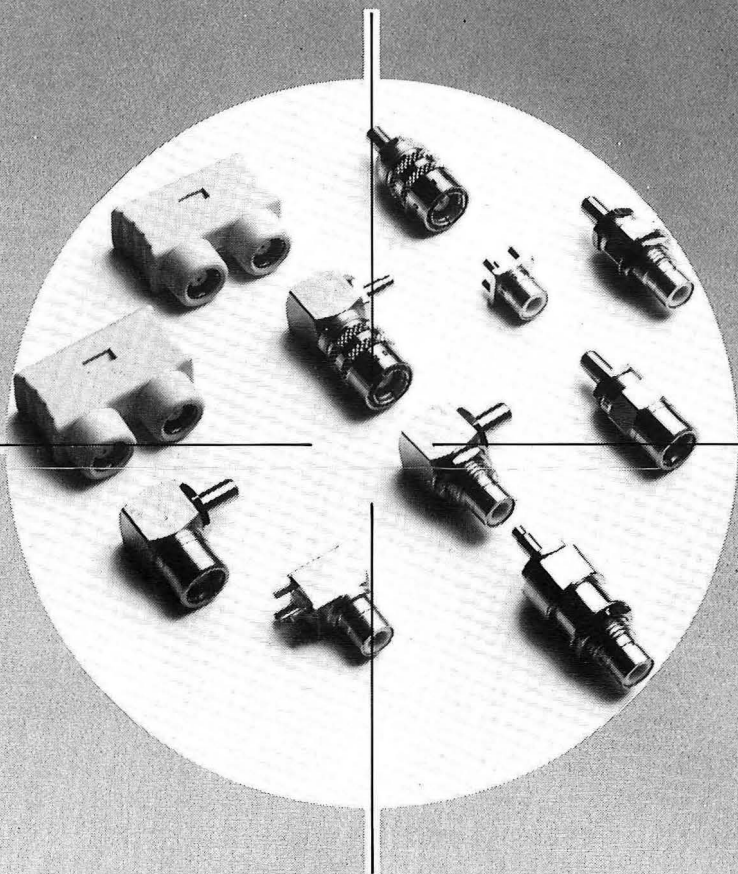

# see the range

# Greenpar

**Greenpar Connectors Ltd.**

P.O. Box 15, Harlow, Essex CM20 2ER

Telephone (0279) 39111

Telex 81404 GRNPAR

# Herman Smith



Metal fabrications and electro-mechanical assemblies to customers' requirements, approved to British Telecommunications and Ministry of Defence standard.

Typical 19" rack, one of several types manufactured suitable for mounting 19" shelves or 8- and 4-unit TEP-1E shelf units, with or without doors.

Ask us to quote for your requirements.

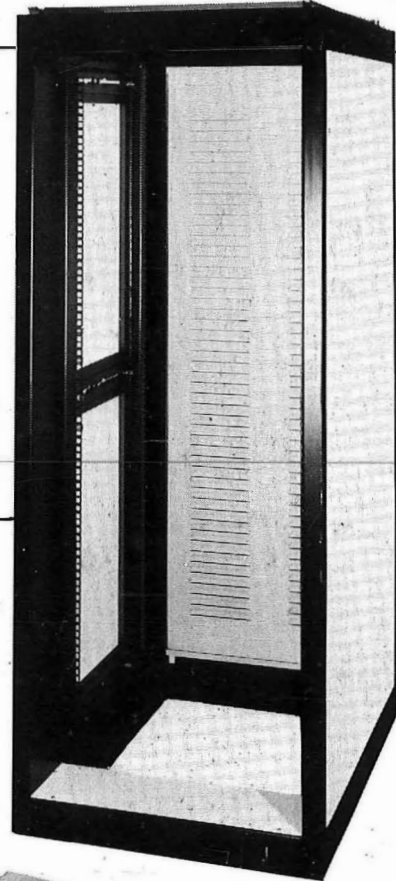
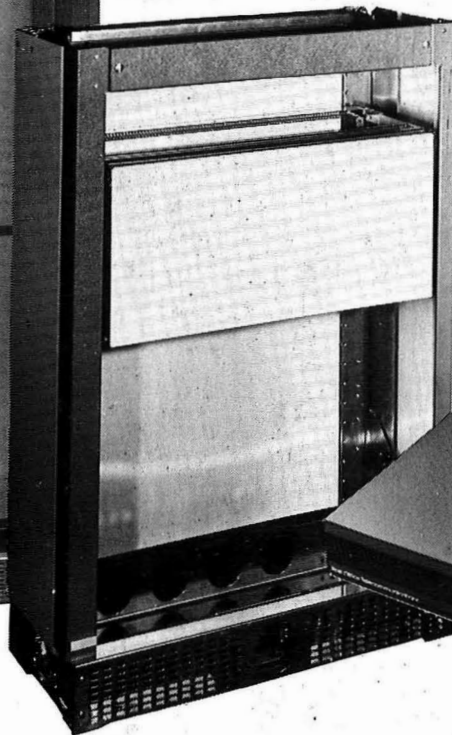
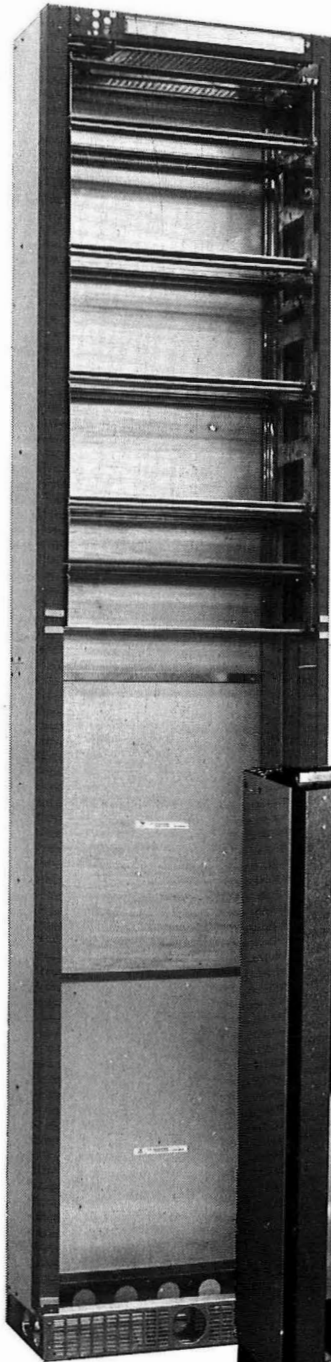

Datel cases to British Telecommunications and contractors' requirements.

\*TEP-1E Rack 80A, 8- and 4-unit shelves in full production. Detailed leaflet on request.

\*TEP-1E is a Registered Trade Mark of the British Telecommunications

**Herman Smith**  
(Eurocraft) Ltd.

A member of the Herman Smith Group of Companies



Fully approved by British Telecommunications  
Ministry of Defence to 05/24 standard and C.A.A.

Netherton, Dudley,  
West Midlands, DY2 9AH.  
Tel: Dudley (0384) 52791.  
Telex: 339962.