

## UNISELECTOR MECHANISMS

CONTENTS

	Page No.
GENERAL	1
P.O. TYPE 1 UNISELECTOR	6
P.O. TYPE 2 UNISELECTOR	11
P.O. TYPE 3 UNISELECTOR	17

GENERALPrinciple of operation

The uniselector is a selector in which the assembly of movable contacting arms, known as wipers, move in one direction only. The wipers rotate about a central shaft and wipe over series of contacts set radially in banks. The uniselectors described in this pamphlet are of the reverse-action type of drive, and Fig. 1 shows, in a simplified form, the mechanical arrangement of this action.

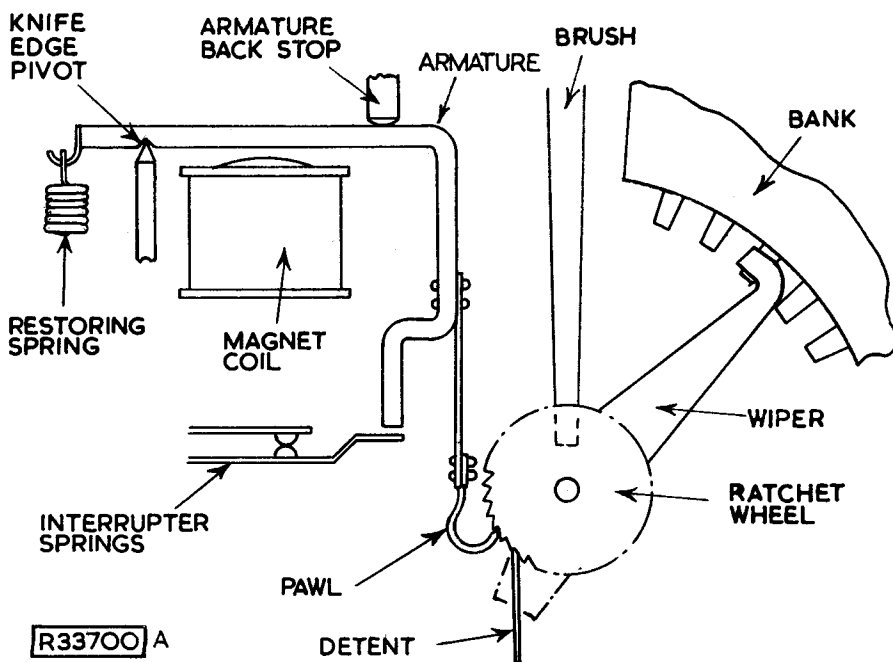

Fig. 1

When current flows in the magnet coil, the armature is attracted and the extension of the armature pushes the pawl forward to engage the next tooth in the ratchet wheel. The armature is operated against the tension of the restoring spring. The detent spring, which is tensioned against the ratchet wheel, prevents movement of the wiper as the pawl is pushed over the ratchet tooth. When the current in the magnet coil is disconnected, the tension of the restoring spring pulls the armature and pawl back to the normal position. In restoring to normal, the pawl pulls the ratchet wheel round, and the wiper moves to the next contact in the bank. This type of drive is known as reverse-action because the ratchet wheel and wiper assembly is moved round as the armature restores to its normal position. To obtain a continuous stepping action, known as "self-drive", interrupter springs, operated by the armature, are fitted to the uniselector. The contacts of the interrupter springs are connected in series with the magnet coil and the battery.

When the magnet coil circuit is completed, the armature is attracted, and towards the end of its operate stroke the interrupter spring contacts open and disconnect the circuit, so allowing the armature to restore. During the release movement of the armature the interrupter spring contacts close and reconnect the magnet coil circuit, thus commencing a new operating cycle. The point in the armature stroke at which the interrupter springs operate is chosen so that the armature has sufficient momentum at that point to complete the operate and release strokes.

### Mechanical Design Details

The tractive force of the electromagnet is approximately inversely proportional to the square of the length of the air gap between the armature and the pole face, and consequently increases rapidly during the armature travel. The force to be overcome by the electromagnet during the operation of the armature also varies from instant to instant. The variation of tractive force, and armature load, with armature travel is shown in Fig. 2. The main portion of the initial load on the armature, OA, is caused by the tension of the restoring springs which hold the armature against the back stop. During the armature travel, the load increases as the restoring springs are extended and as the pawl slides along the long face of the ratchet tooth, deflecting the pawl spring.

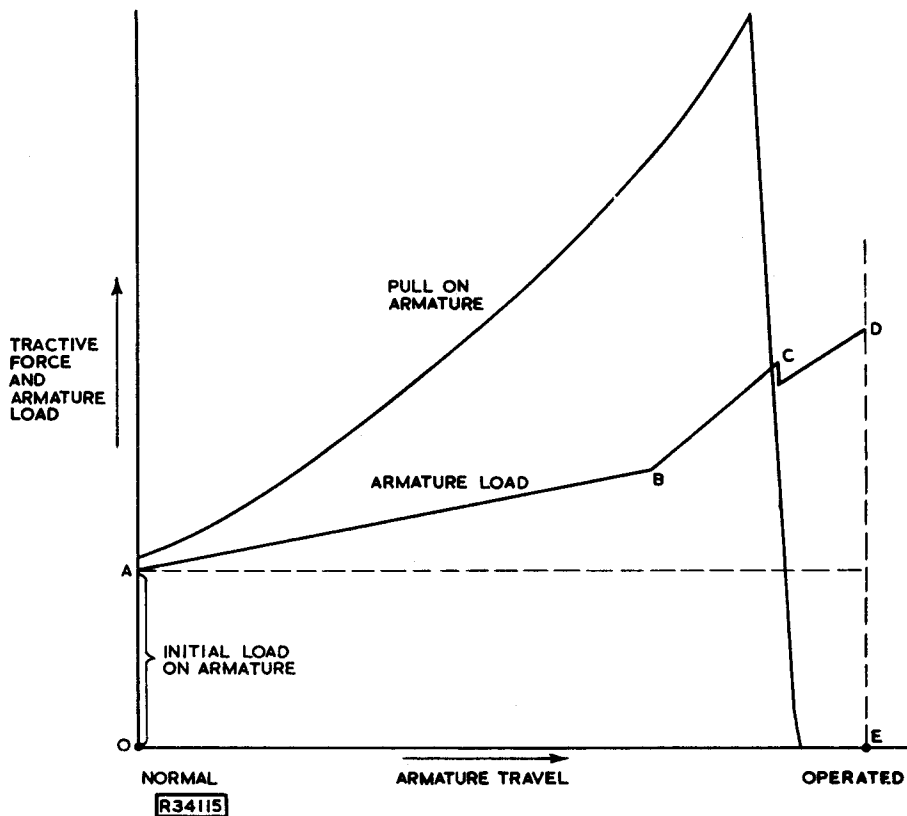

Fig. 2

At point B a further increase in load takes place as the interrupter striker meets the interrupter spring. The load on the armature continues to increase until, at point C, the pawl drops over the next tooth on the ratchet wheel and

reduces the load due to the pawl spring. At a point between B and C the interrupter springs open and disconnect the magnet coil circuit, so removing the tractive force, but the momentum of the armature assembly carries it forward to complete its stroke. The major portion of the armature load represented by the distance between the points D and E is the force in the armature restoring springs and this will be used to restore the armature to normal, at the same time moving the wipers to the next contact.

During the restoration of the armature, the armature restoring springs have to overcome the following forces:-

- (a) friction between the wipers and bank contacts,
- (b) friction between the detent spring and the surface of the long face of the ratchet wheel tooth,
- (c) friction between the wiper assembly and the wiper assembly bearing pin,
- (d) friction between the brushes and the collector rings, and
- (e) any residual magnetism in the armature and magnet core.

The forces in (c) and (d) do not vary during the restoration of the armature and that in (e) is reduced to a negligible amount by the use of a residual plate fixed either to the pole face of the magnet or to the armature. The variation of the forces in (a) and (b) and the variation of the force in the restoring springs during the restoration of the armature are shown in Fig. 3. When the armature is in the operated position, the force to restore it to normal is made up of the pull of the restoring springs and the tension of the interrupter spring. At point A during the release of the armature, the interrupter springs close, so removing their

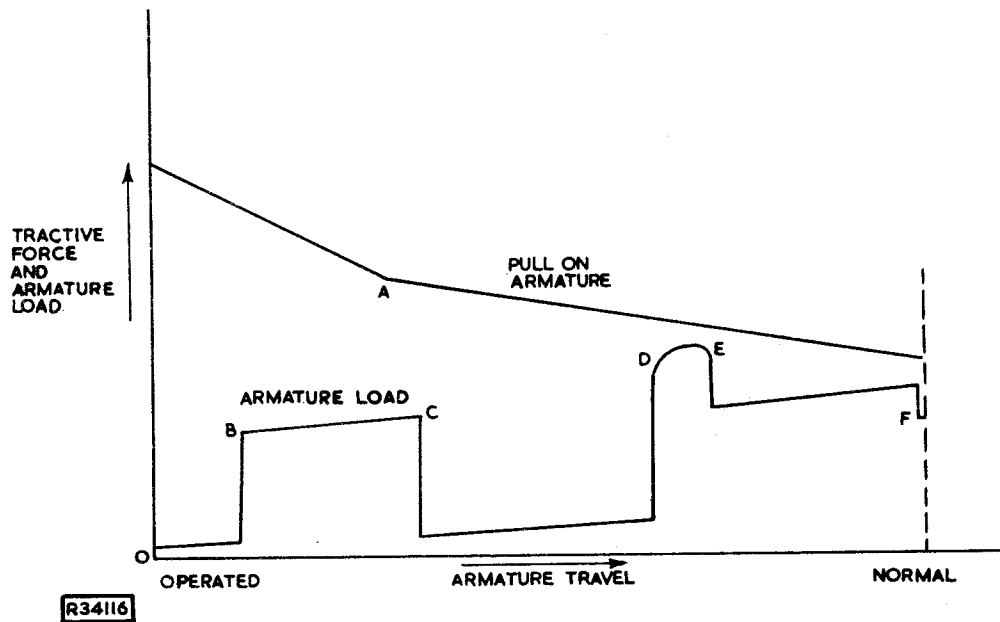

Fig. 3

restoring effect from the armature. From this point onwards the release of the armature is dependent upon the force remaining in the restoring springs. At the beginning of the armature release it has a small load which is mainly due to the friction of the pawl against the long face of the ratchet tooth. When the pawl meets the short face of the ratchet tooth, and commences to move the wiper assembly, the armature load increases as shown at point B, due to the friction between the wipers and the bank contacts. Between points B and C the wipers are moving over the bank contacts, and the rise in load between the two points is caused by the increasing pressure of the detent spring as it slides up the long face of the ratchet tooth. At point C the wipers leave the contacts, so reducing the load to a value mainly dependent upon the pressure of the detent spring on the ratchet wheel. When the wipers reach the next bank contacts, there is a large increase in the load for a short period, points D to E, as the wiper blades are forced outwards by the contacts. At point E the armature load is reduced as the wipers move on to the bank contacts, and at point F it is further reduced when the detent engages the next tooth in the ratchet wheel just before the end of the armature stroke.

Under certain circuit conditions the tip of the wiper is shaped so that as the wiper steps from one contact to the next the tip momentarily connects the two contacts together. This type of wiper, known as a "bridging" wiper, maintains a

reasonably constant load on the armature as it steps round the bank, and in consequence of this the reduction in armature load at point C in Fig. 3 will be reduced if the wiper assembly includes one or more of the bridging type wipers. Also, in practice the load on the armature will be increased because the bridging type wiper has a larger wiping surface than the non-bridging type, as shown in Fig. 4.

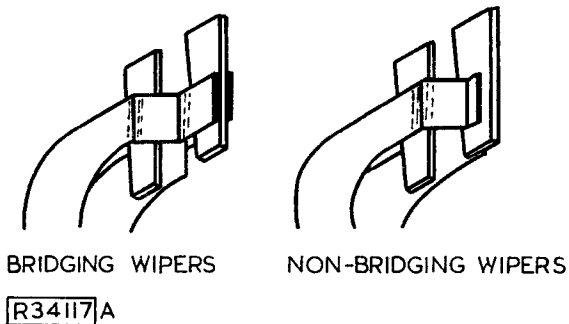

Fig. 4

The magnitude of a frictional force depends upon the state of the surfaces concerned and is proportional to the pressure between them. In the uniselector mechanism these forces are, where practicable, reduced by lubrication of any surfaces that make a rubbing contact, and by keeping the pressure between the surfaces within specified limits. In considering the effects of any of the forces, the force must be considered in relation to the appropriate axis of movement, e.g. the movement of the force due to friction between the wipers and the bank contacts would be the product of the magnitude of the friction and the effective radius of the bank.

For the uniselector to perform satisfactorily there must be a clearance at any instant between the curves representing the tractive force on the armature and the load on the armature. At any instant the distance between the curves represents a margin of safety on the mechanism; in the example shown in Fig. 3 the lowest margin of safety, hence the most likely point of failure, occurs when the wipers meet the next set of contacts.

Contact Banks and Wipers

The uniselector bank consists of from 3 to 10 rows of contacts, known as levels, and each row of contacts is arranged over an arc of  $172^{\circ} 48'$ . The levels are insulated from each other and separated by aluminium plates to provide mechanical rigidity and to reduce electrostatic induction between the levels. The contact levels and spacing plates are clamped between two zinc-plated mild-steel plates, one of which has its ends bent at right angles across the ends of the levels. The two plates so formed are suitably drilled to provide a means of fixing the mechanism to the bank and the bank to a shelf. The shelf is made from two horizontal lengths of angle iron, suitably spaced so as to provide a fixing point for each of the plates. To prevent the vibration caused by the uniselector mechanism from being transmitted to adjacent equipment, the bank is fixed to the shelf by means of spring clips.

There are three types of contact levels, (a) 25 individual contacts equally spaced over the arc, (b) a single contact followed by a solid arc covering the space normally occupied by the other 24 contacts, and (c) a single contact followed by a solid arc covering the space normally occupied by contacts 2 to 11, then a single contact followed by a solid arc covering the space normally occupied by contacts 13 to 25. There is usually only one contact level of type (b) or (c) in a contact bank.

The number of wipers mounted side by side to form the wiper assembly corresponds to the number of contact levels, and double-ended wipers, Fig. 5a, are used in order that the stepping time from contact 25 to contact 1 will be the same as the stepping time from contact 1 to contact 2. The availability of the uniselector may be increased from 25 to 50 by having two single-ended wipers set  $180^{\circ}$  apart and electrically connected, rotating over two separate contact levels.

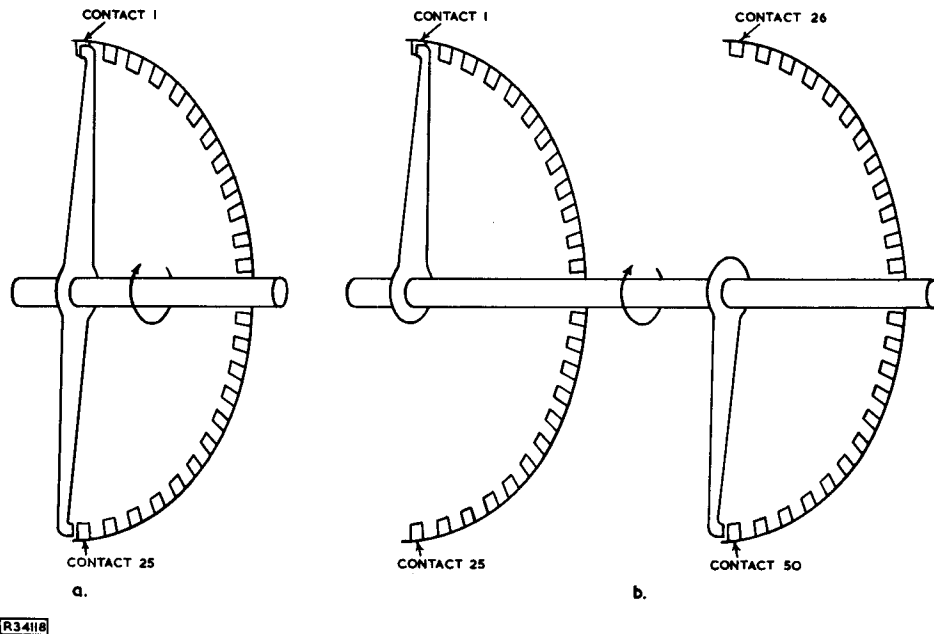

Fig. 5

half revolution of the wiper shaft, one set of wipers rotates over one set of 25 contacts, and during the next half revolution the other set of wipers rotates over the other 25 contacts. Thus, during one complete revolution, the wiper unit wipes over 50 individual contacts. This arrangement is shown in Fig. 5b. Each wiper is in contact with a brass collector ring, and the wipers, collector rings and insulators are clamped together on a steel tube, with an index wheel at one end and the ratchet wheel at the other. The index wheel indicates the bank contact on which the wiper assembly is standing, it has 25 or 50 divisions depending on whether the wiper assembly is composed of double-ended or single-ended wipers.

The pointer associated with the index wheel is positioned so that,

- (a) on homing type uniselectors the first bank contact is numbered '0', i.e. the bank contacts number 0 to 24 or 0 to 49;
- (b) on non-homing type uniselectors the first bank contact is numbered '1', i.e. the bank contacts number 1 to 25 or 1 to 50.

#### P.O. TYPE 1 UNISELECTOR

The mechanism of the P.O. Type 1 Uniselector is made in two sizes, the smaller size to fit banks having 3 to 5 levels and the larger size to fit banks having from 6 to 10 levels. The two uniselectors are shown in Figs. 6 and 7. The larger type of uniselector has larger and more powerful magnet coils, but the chief mechanical difference is in the pawl spring arrangements which can be clearly seen in Figs. 6 and 7.

The mechanical arrangement of the smaller uniselector is shown in Fig. 8. The armature assembly is hinged on a knife edge, and held firmly against the back stop by the adjustable steel restoring springs, which have felt inserts moistened with oil to reduce vibration. The two magnet coils are positioned by the adjusting glands, so that when the armature operates it strikes both magnet cores simultaneously and pushes the pawl forward to the next tooth on the ratchet wheel. With the mechanical arrangement used in this type of uniselector it would be possible for the inertia of the armature lever and pawl to lift the armature away from the knife edge, thus allowing the pawl to move forward more than one tooth on the ratchet wheel. This is prevented by means of a forward stop for the armature lever. The pawl has a case-hardened tip, and is joined to the armature lever by a flat steel spring which is tensioned so that the pawl exerts a pressure of the order of 175 grammes on the ratchet wheel. With the mechanism in the normal position the pawl stop is positioned so that the pawl is lightly wedged between the pawl stop and the ratchet wheel; this adjustment prevents overshoot of the wiper assembly as it is stepped from contact to contact. The detent spring prevents movement of the wiper assembly when the armature operates, and in practice it is tensioned to exert a pressure of the order of 150 grammes on the ratchet wheel.

The interrupter spring-set consists of one fixed and one moving spring, each fitted with a platinum contact. The moving spring is so placed that it is struck during each armature operation by an insulated stud fixed to an extension of the armature. The instant of interruption may be varied by bending the armature extension.

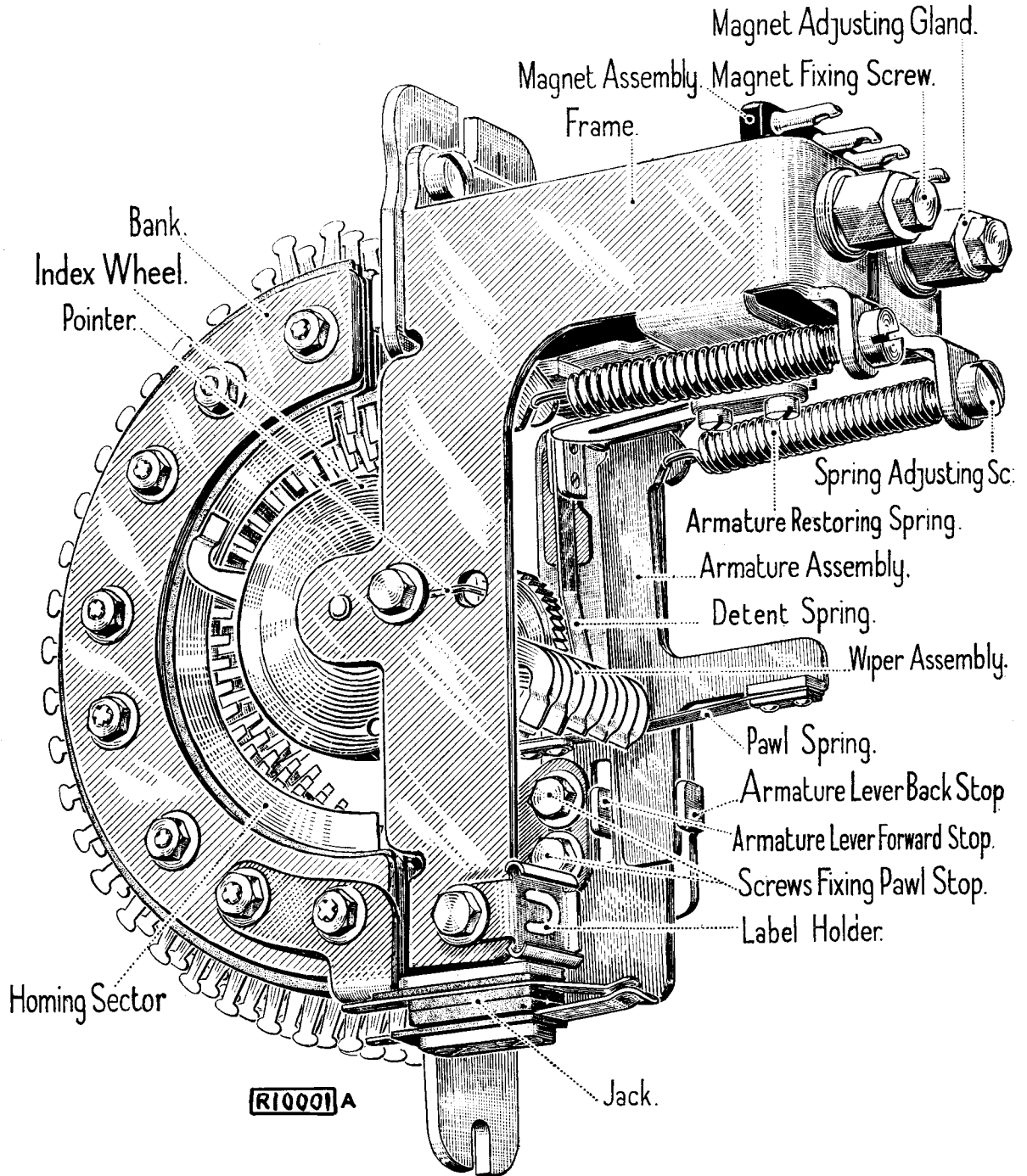

Fig. 6

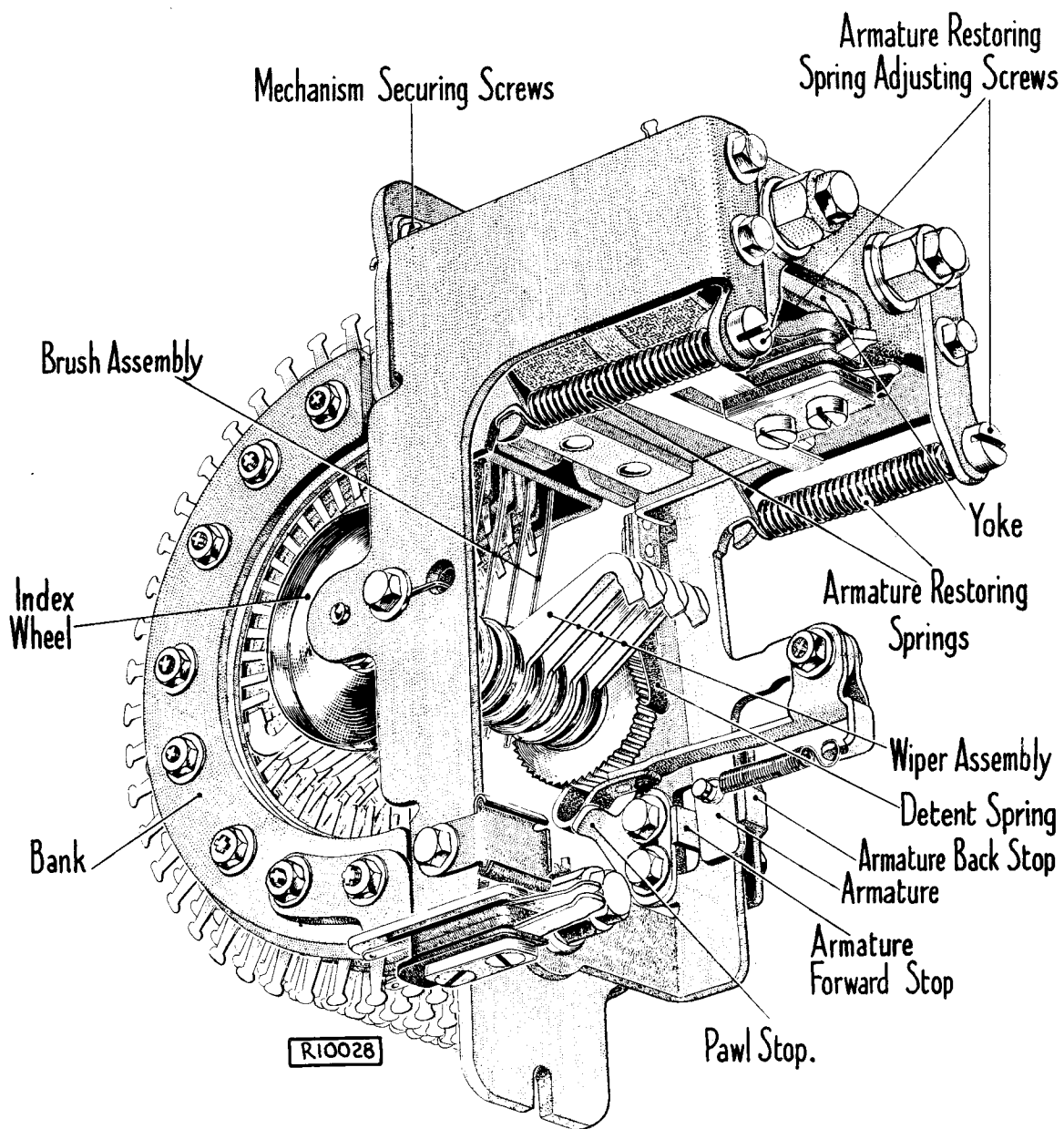

Fig. 7



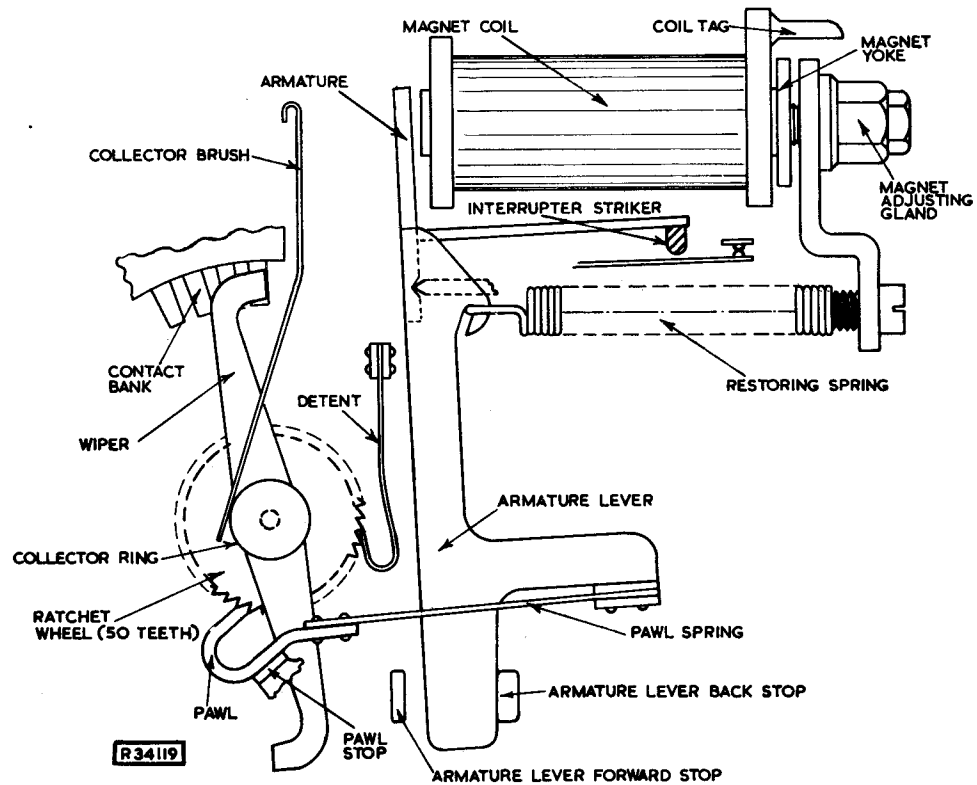

Fig. 8

The ratchet wheel is of brass and is mounted on a steel tube on which the phosphor bronze wipers, brass collector rings and any necessary insulation are assembled. An index wheel is also mounted on the tube and the whole assembly is then clamped together to form a rigid wiper assembly. The wiper assembly rotates on a steel shaft which is screwed into the right-hand side member of the uniselector frame. Electrical connexions to the wipers are made by bronze wires resting in the grooved collector rings, as shown in Fig. 9, each collector ring being in metallic contact with a wiper. In practice the bronze wires, known as brushes, exert a pressure of the order of 35 grammes on the collector rings, and the wipers exert a pressure of the order of 30 grammes on the bank contacts.

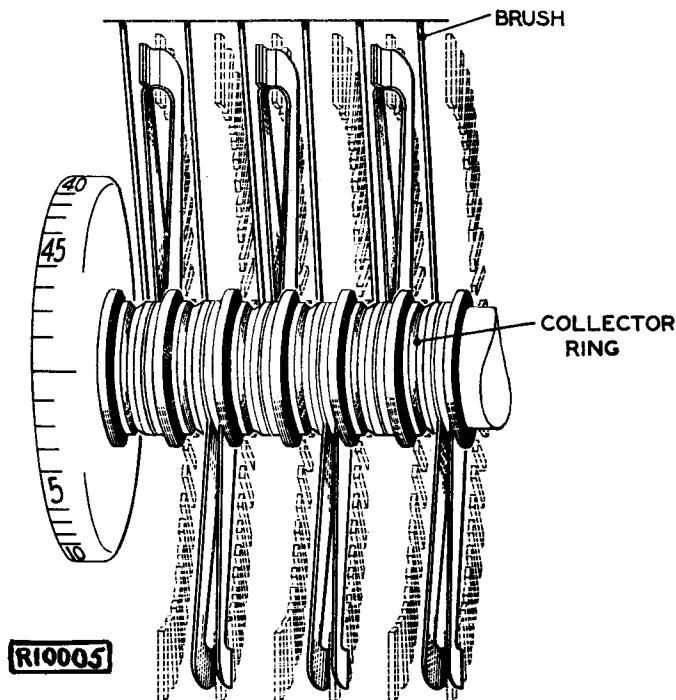

Fig. 9

The magnet coils are connected so that, under operated conditions, the armature forms part of a closed magnetic circuit. Brass residual caps are fitted to the core faces of the coils used in the larger mechanisms to assist the armature release. As the position of the wipers with respect to the ratchet wheel is fixed, the mechanism can only be adjusted when fixed to its bank. The initial adjustment of the armature back stop must ensure that the wipers are correctly positioned on the first bank contact. The detent, pawl stop, and the armature travel are then adjusted to suit. The self-drive speeds of the Type 1 uniselector under various voltage conditions are tabulated below:-

Working voltage	60 V.	50 V.	40 V.	22 V.
Maximum speed of all uniselectors	100 r.p.m.	100 r.p.m.	100 r.p.m.	80 r.p.m.
Minimum speed 3 to 5 level type	60 r.p.m.	60 r.p.m.	60 r.p.m.	55 r.p.m.
Minimum speed 6 to 10 level type	50 r.p.m.	50 r.p.m.	50 r.p.m.	45 r.p.m.

P.O. TYPE 2 UNISELECTOR

This type of uniselector supersedes the Type 1 uniselector for all purposes except subscribers' calling equipments. It is made in two frame sizes, one to fit banks of up to 5 levels and the other to fit banks of from 6 to 10 levels. The mechanical details of both sizes are identical except for the width of the frame and the wiper assembly. With the correct type of brush feed fitted to the bank the Type 2 uniselector is, except with certain types of mounting, interchangeable with the corresponding Type 1 uniselector.

The mechanical arrangement of the Type 2 uniselector mechanism is shown in Fig. 10.

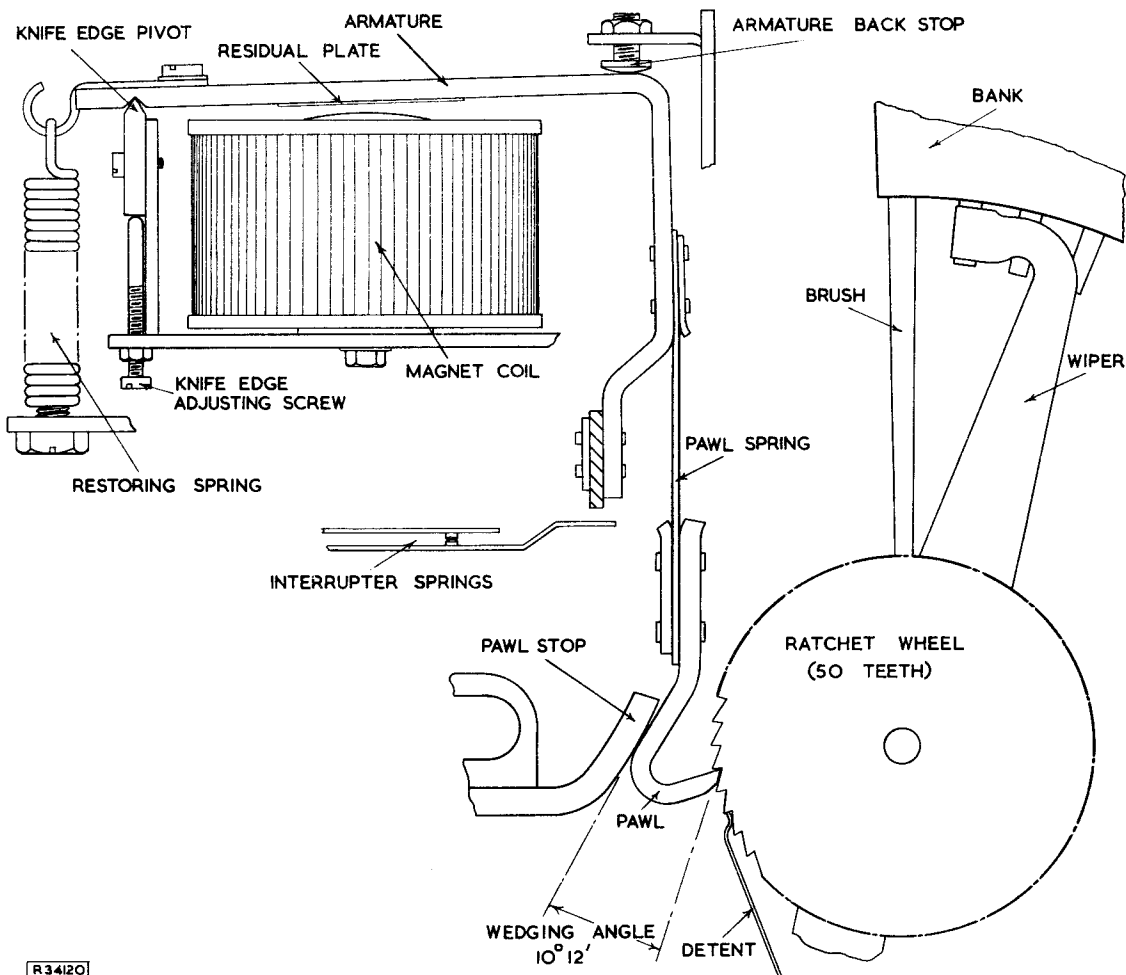

Fig. 10

There are three important differences in the armature arrangements from those used in the Type 1 uniselector.

(a) The coil and pawl are on the same side of the knife edge. This stops the armature leaving the knife edge at the end of its stroke and so dispenses with the need for an armature front stop.

(b) The coil assembly is fixed to the yoke so making an efficient magnetic joint between the core and the yoke. For adjustment purposes the armature is moved in relation to the coil by adjustment of the knife edge.

(c) The armature is lighter, with a consequent reduction in wear at the bearing surfaces.

Special attention has been given to the design of the detent, pawl and pawl back-stop to minimize wearing of the ratchet teeth and to prevent the pawl jamming between its back-stop and the ratchet wheel when the armature restores to normal.

When the armature is normal, the pawl is lightly wedged between the ratchet wheel and the pawl back-stop. The pawl is prevented from jamming, and so delaying the operation of the armature, by setting that surface of the pawl which meets the back-stop at a suitable angle to the long face of the ratchet tooth. This angle is indicated as the "wedging angle" in Fig. 10. The back of the pawl is cambered across its width so that the thrust of the back-stop will always be on the centre line of the pawl. The back-stop is curved, to ensure that even if it is slightly out of correct adjustment, it will make contact near the correct point on the pawl and so not impose excessive strain on the pawl spring. The end of the pawl-spring clamping plate is curved outwards as shown in Fig. 10, so that as the pawl moves the spring gradually flexes on the curved surface, taking the load smoothly and without concentrated stresses at any point. The pawl spring is tensioned so that the pawl exerts a pressure on the ratchet wheel of the order of 200 grammes. The pawl tip is case-hardened and shaped as shown in Fig. 10 to avoid hammering on, and consequently wearing, the tips of the ratchet teeth.

The detent is mounted tangential to the ratchet wheel, so that the movement of its tip is parallel to the short face of the ratchet tooth, and the end is so formed that it rests on the long face of the ratchet tooth. As movement of the detent tip is parallel to the short face of the tooth, wear on the teeth will not cause back lash of the wiper assembly as it is stepped round the bank.

The Type 2 Uniselector that will fit banks having from 6 to 10 levels is shown in Figs. 11 and 12.

The wiper assembly consists of the index wheel, collector rings, wipers and insulators, clamped together on a stainless steel sleeve. This assembly fits over a tubular extension of the ratchet wheel, and is locked to it by a clamp, which fits over the split portion of the extension projecting into the well formed by the index wheel. The position of the wipers relative to the ratchet wheel is determined when the uniselector mechanism is fitted to the bank. The combined wiper and ratchet wheel assembly rotates on a steel spindle which screws into the uniselector frame as shown in Fig. 12.

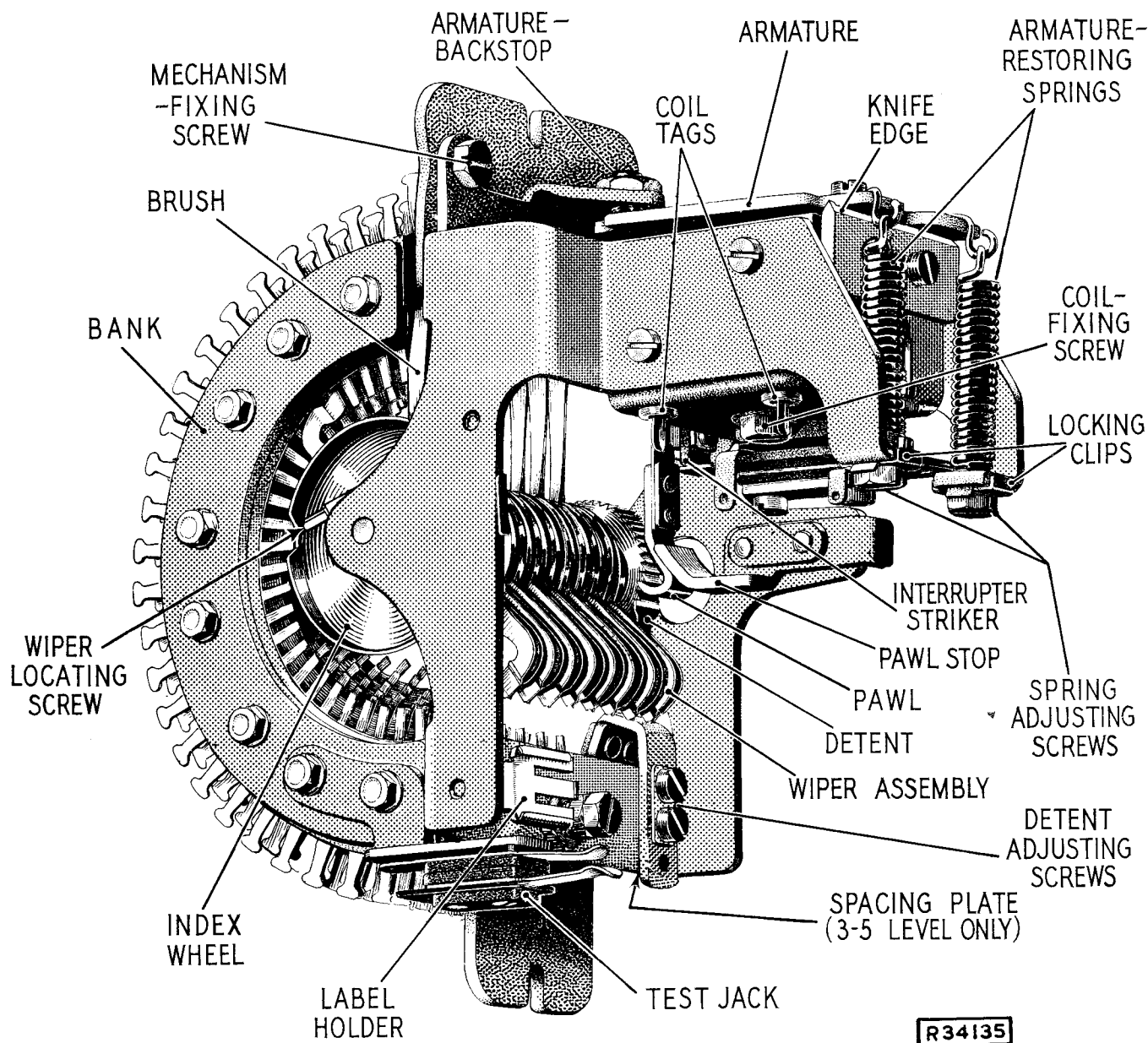
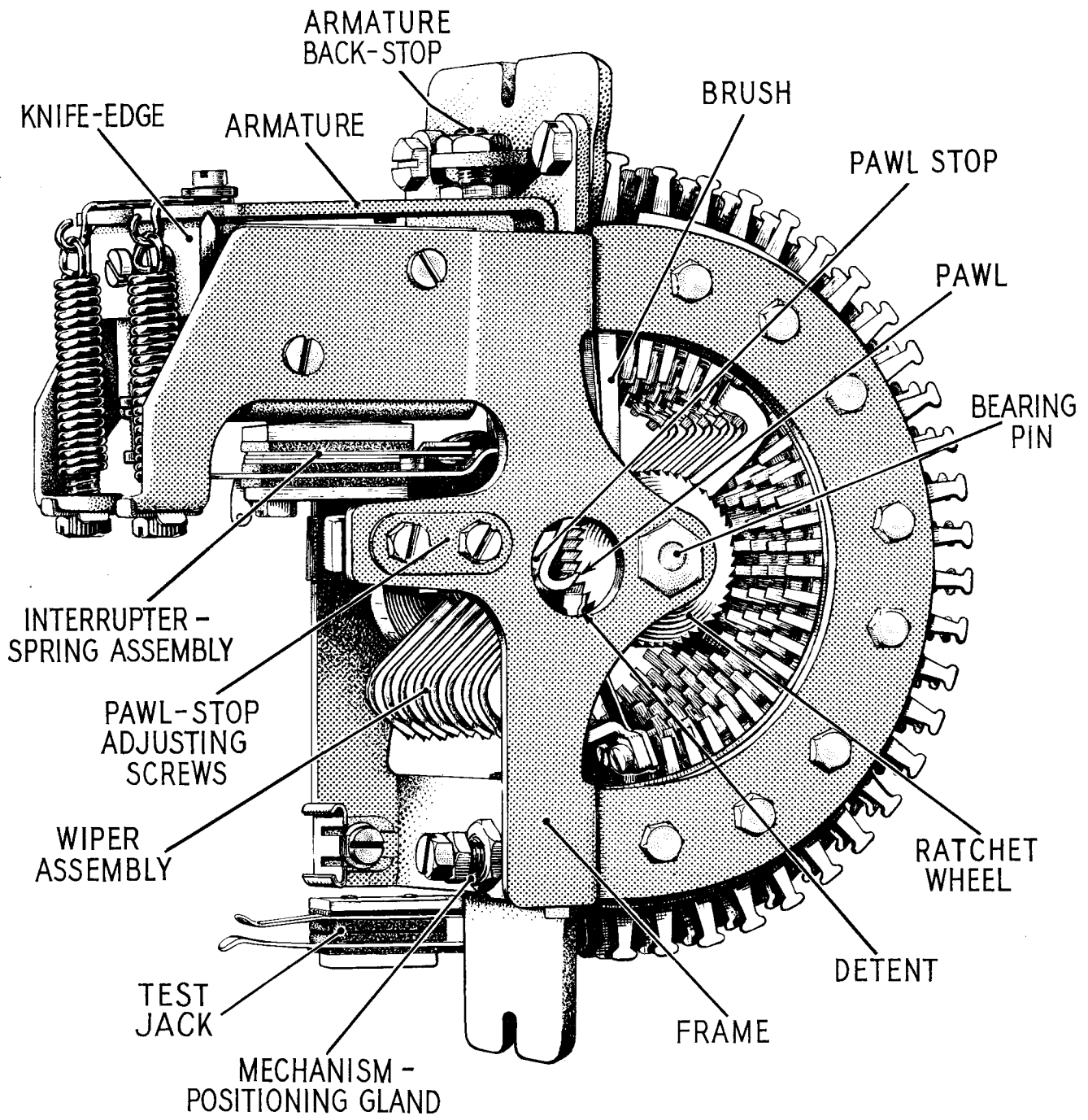

Fig. 11  
13



R34136

Fig. 12

The tips of the wipers are shaped to allow the wiper assembly to be moved round the bank in either direction without fouling the contacts, this facility being required during the adjustment of the mechanism.

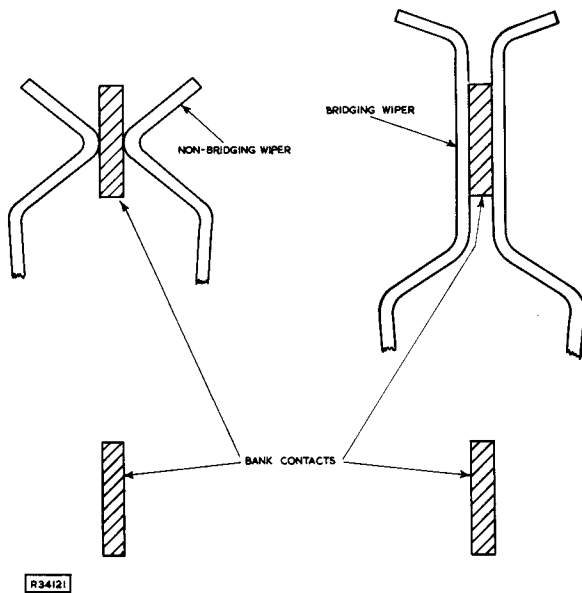

Fig. 13

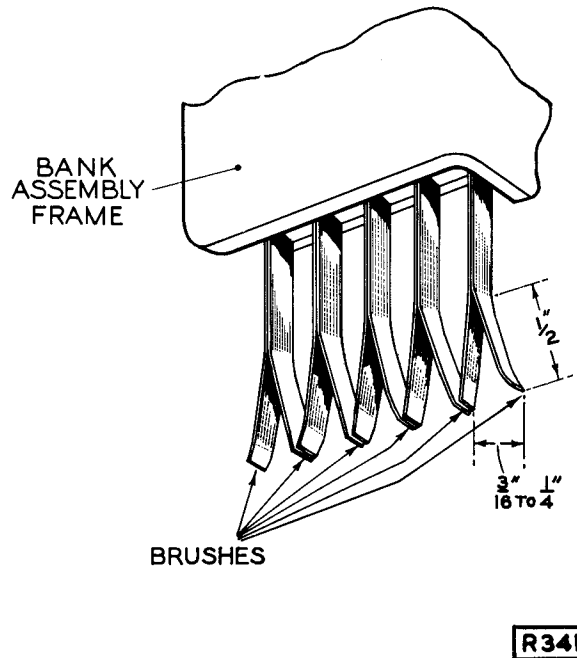

Fig. 14

The relative positions of a non-bridging and a bridging type wiper on a bank contact, when both types of wiper are included in the same wiper assembly, is shown in Fig. 13. On a wiper assembly having all bridging type wipers, the wipers are positioned so that the whole width of the bank contact is embraced within the wiping surfaces of the wipers. In practice the wipers exert a pressure on the bank contacts of the order of 30 grammes. Current is fed to and from the wipers by flat outward-bearing brushes, running in parallel-sided collector rings. The feeder brushes, shown in Fig. 14, the collector rings and the wipers are made of nickel silver.

The interrupter springs are mounted on a rocker plate, Fig. 15, so that by adjustment of the two screws the interrupter can be positioned for correct operation without affecting the contact spring tension. The interrupter is operated by a striker of bakelised material, riveted to an extension of the armature. The interrupter contacts are of tungsten and the design of the springs is such that, as the contacts make and break, there is a slight rubbing action between them. This rubbing action is necessary to break down the oxide coating of high electrical resistance that forms on tungsten under normal atmospheric conditions. Tungsten is used for the contacts because of its toughness and high melting point.

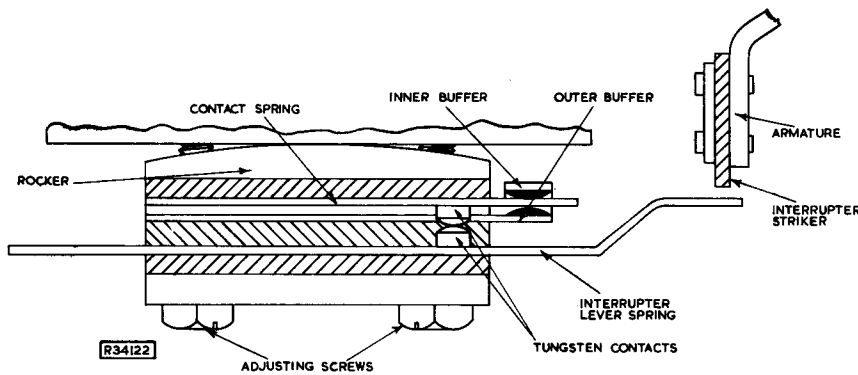

Fig. 15

The electro-magnets of the Type 1 Uniselectors give an insufficient margin of power with heavy wiper loads, so a more powerful electro-magnet system has been designed for the Type 2 and 3 Un-selector. A single coil is used, wound on a large diameter core and fixed in a box-shaped yoke, with the armature completing the magnetic circuit as shown in Fig. 16.

Although in practice the armature does not touch the top edges of the yoke when operated, this arrangement produces a magnetic circuit of low reluctance. The large coil, which has a resistance of 75 ohms for 50 volt working, and the efficient magnetic circuit give ample margin of power under all normal conditions of adjustment and voltage. A non-magnetic residual plate of "Staybrite" stainless steel is fitted to the armature, to give a uniform time of release under various conditions of operation; stainless steel is used in preference to nickel silver because the residual plate also

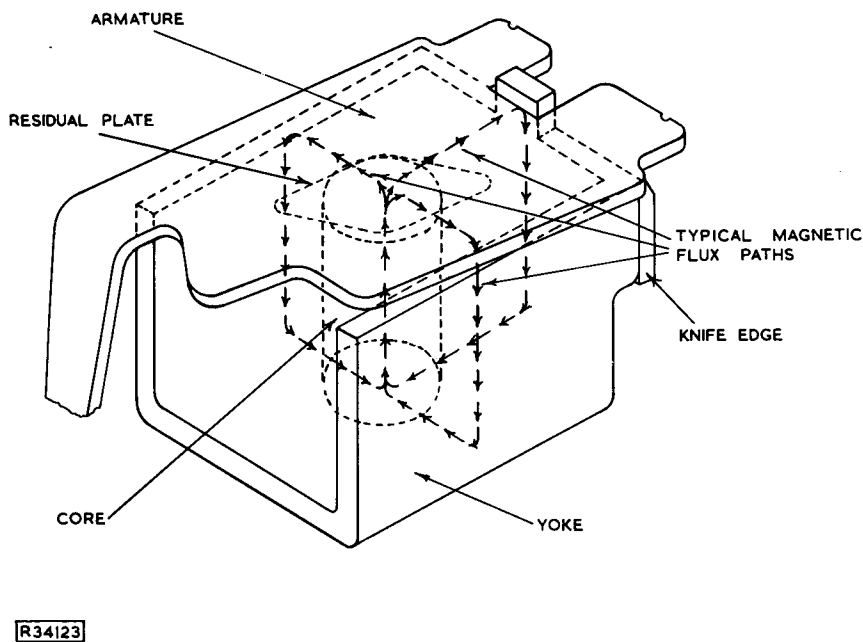

Fig. 16

acts as the armature front stop.

As the wipers can be moved relative to the ratchet wheel, the mechanism can be adjusted out of the bank. The magnet coil is fixed and this is used as the reference point for the adjustment. The knife edge is positioned so that the armature, when operated, touches the core and lies parallel to the top edges of the



yoke. The detent is positioned with the armature in the operated position, the armature back-stop and pawl back-stop are then adjusted so that, when the armature is released, the detent engages with the next tooth on the ratchet wheel. The mechanism is fitted to the bank for the final adjustment of the wipers, feeder brushes, armature restoring springs and interrupters.

The self-drive speed, operate and release times are substantially the same as for the Type 1 uniselectors, so that changes to circuit design when the mechanisms are interchanged are not required. The operate and release times of the Types 1 and 2 Uniselectors for 50 volt working are tabulated below:-

Uniselector		Operate time	Release time
Type 1.	Not more than 5 levels	8 to 25 milli. secs.	5 to 10 milli. secs.
Type 2.	" " " "	8 to 22 " "	5 to 12 " "
Type 1.	Over 5 levels	12 to 23 " "	3 to 9 " "
Type 2.	" " "	13 to 30 " "	3 to 10 " "

P.O. TYPE 3 UNISELECTOR

The Type 3 uniselector shown in Figs. 17 and 18 supersedes the Type 1 uniselector for subscribers' calling equipments and can, with the correct type of brush feed fitted to the bank, replace existing Type 1 mechanisms. It is simpler in design and of lighter construction than the Type 2 mechanism, although incorporating many of the refinements introduced on that uniselector, and is made with a frame size to fit banks with 4 or 5 levels.

By employing a different form of wiper-assembly adjustment, reducing the width of the ratchet wheel and eliminating projecting screw-heads, the width of the mechanism has been reduced to less than  $1\frac{3}{4}$  inches. This has enabled a new subscribers' calling equipment rack to be designed which is capable of accommodating 50 per cent more calling equipments in the same floor space. The main differences from the Type 2 uniselector are in the wiper assembly and the interrupter springs.

The wiper assembly and ratchet wheel are manufactured as one unit, although the facility of relative adjustment is still provided. To transmit the drive from the ratchet wheel to the wiper assembly a flat arm has one end riveted to the ratchet wheel hub and the other end fixed to the index wheel. This fixing consists of a screw, fixed to the arm, passing through a slot in the index wheel and secured by a nut. The length of the slot is such as to allow relative movement over  $1\frac{1}{2}$  contacts. The wipers, collector rings and feeder brushes have the same shape as those used on the Type 2 mechanism. Nickel silver is used for the wipers, bank contacts and feeder brushes, but brass, because it is easy to machine, is used for the collector rings.

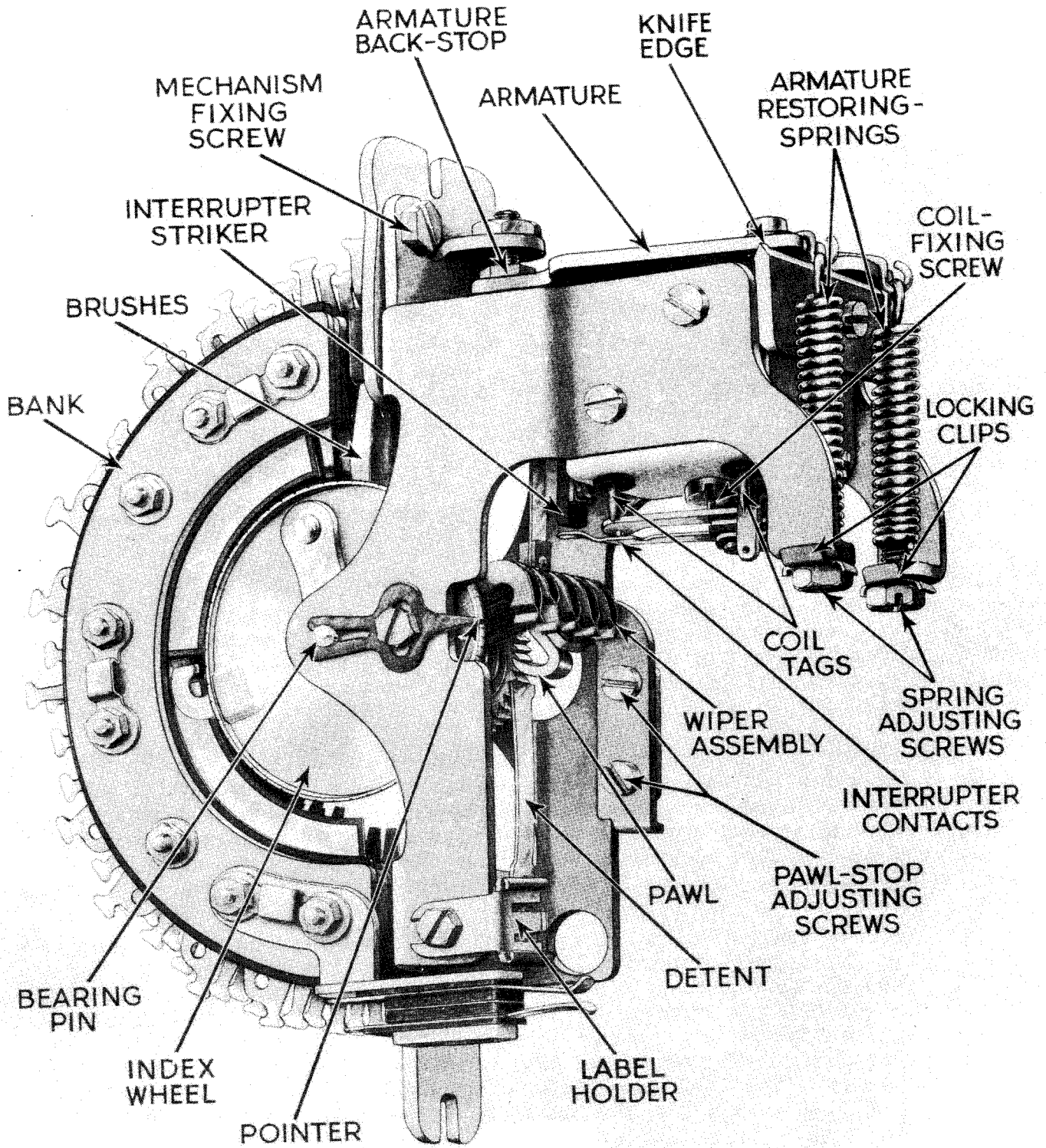

R34138

Fig. 17

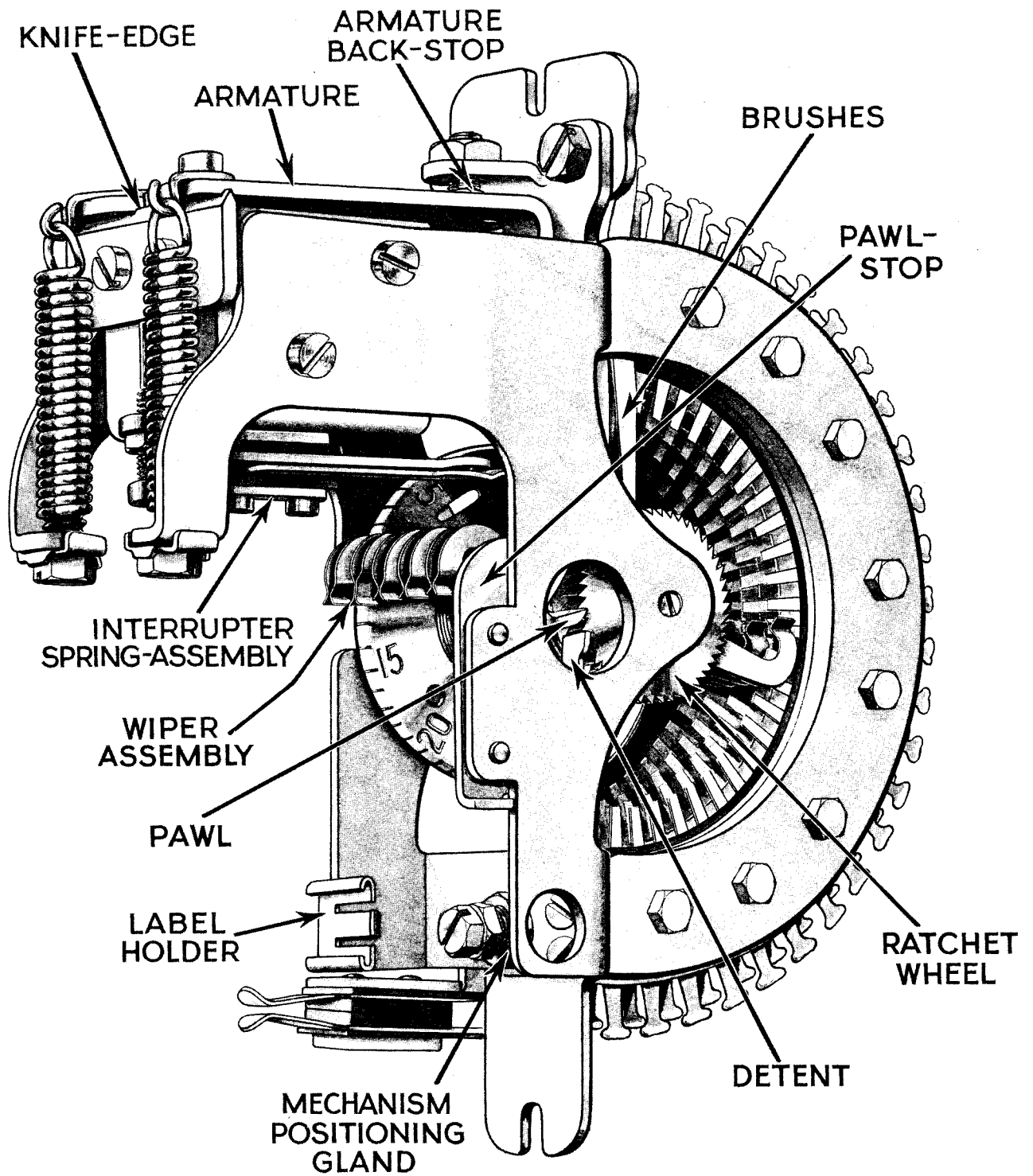

R34139

Fig. 18  
19

The interrupter assembly is similar to that used on the smaller pattern Type 1 uniselector and consists of a stiff, fixed contact spring and a thinner lever spring as shown in Fig. 19. The contact material is platinum and the instant of interruption is varied by adjustment of the contact spring.

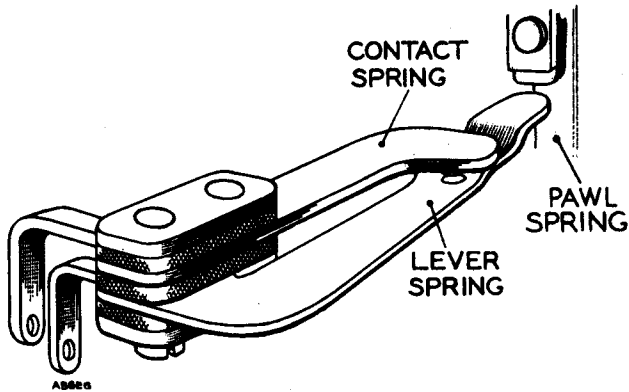

The magnet coil is wound with enamel-covered wire, the enamel being such as to resist the effects of high temperature, and it has a resistance of 100 ohms for 50 volt working.

The adjustment technique is the same as that used with the Type 2 mechanism and the self-drive speed limits are the same as for the Type 1 uniselector.

R34140

Fig. 19

END