

## LOCAL BATTERY AND CENTRAL BATTERY TELEPHONES

CONTENTS

	Page
Introduction	1
Principles of Operation	2
Principles of the Anti-sidetone Induction Coil Circuit	6
Practical A.S.T.I.C. Telephone Circuits	11
Shared Service Telephones	22
Portable Telephone	27
Conclusions	28

Figs. 5, 16, 17, 18, 21, 23, 38, 40, 42 and 43 are appended to this pamphlet.

INTRODUCTION

This pamphlet describes in some detail the operating principles of the common types of telephone set that are installed at subscribers' premises. Later pamphlets in this series will deal with extension plan numbers, house exchanges and private branch exchanges.

To transmit sound from one place to another, other than directly through air or similar sound-conducting media, an arrangement is required consisting of:-

- (a) An instrument to convert the energy of the sound waves into energy of a different form.
- (b) A medium through which the energy can travel.
- (c) A second instrument which re-converts the energy received into sound waves similar to those originally produced.

The instruments required in (a) and (c) are known as a transmitter and receiver respectively. It will be found that the term 'transducer', i.e. a power-transforming device for insertion between electrical, mechanical or acoustic parts of systems of communication, is sometimes used for the transmitter or receiver. The transmitter consists essentially of a quantity of carbon granules packed between two carbon electrodes. One electrode is fixed while the other is firmly attached to a diaphragm. The receiver consists essentially of a permanent magnet together with an electromagnet mounted in close proximity to a diaphragm. These instruments are described in detail in Educational Pamphlet - Draft Series - General 4/1. The transmitting medium, as far as this aspect of telephony is concerned, is a pair of metal wires.

The design of the circuit which incorporates the transmitter and receiver, i.e. the telephone circuit, must satisfy the following conditions:-

(a) The signalling path through the telephone must have a low resistance to allow the majority of the permissible signalling path resistance to be in the line. The transmitter is usually in the signalling path, consequently it must have a resistance which is low compared with that of the line.

(b) The circuit must work efficiently in an existing line network which consists of lines having a wide range of impedances.

(c) The circuit must work efficiently when connected to a telephone circuit of earlier design.

(d) The circuit must include a device which will respond to the incoming alternating current ringing signal; in practice the device is usually a magneto bell.

### PRINCIPLE OF OPERATION

#### General

Fig. 1a shows a simple circuit which enables one person to talk to another. The battery may be considered as being positioned midway between the transmitter and the receiver. Under quiescent conditions, a steady current flows the magnitude of which is determined by the total circuit resistance presented to the battery. When a sound wave impinges on the transmitter diaphragm however, the resulting vibrations of the diaphragm vary the pressure on the carbon granules, thus causing the resistance of the transmitter to vary about its mean value. The current changes in the circuit also vary about the mean value in accordance with the changes of resistance of the transmitter. In the absence of a sound being applied to the transmitter, the steady current flowing through the receiver determines the mean pull on its diaphragm. When the current commences to vary about its mean value, the pull on the diaphragm also varies. The sudden changes of position of the receiver diaphragm produce changes of air pressure in the immediate vicinity of the receiver. These changes of pressure are heard and the sound reproduced is the same as the original sound applied to the transmitter. Bothway conversation is possible with the simple circuit shown in Fig. 1b.

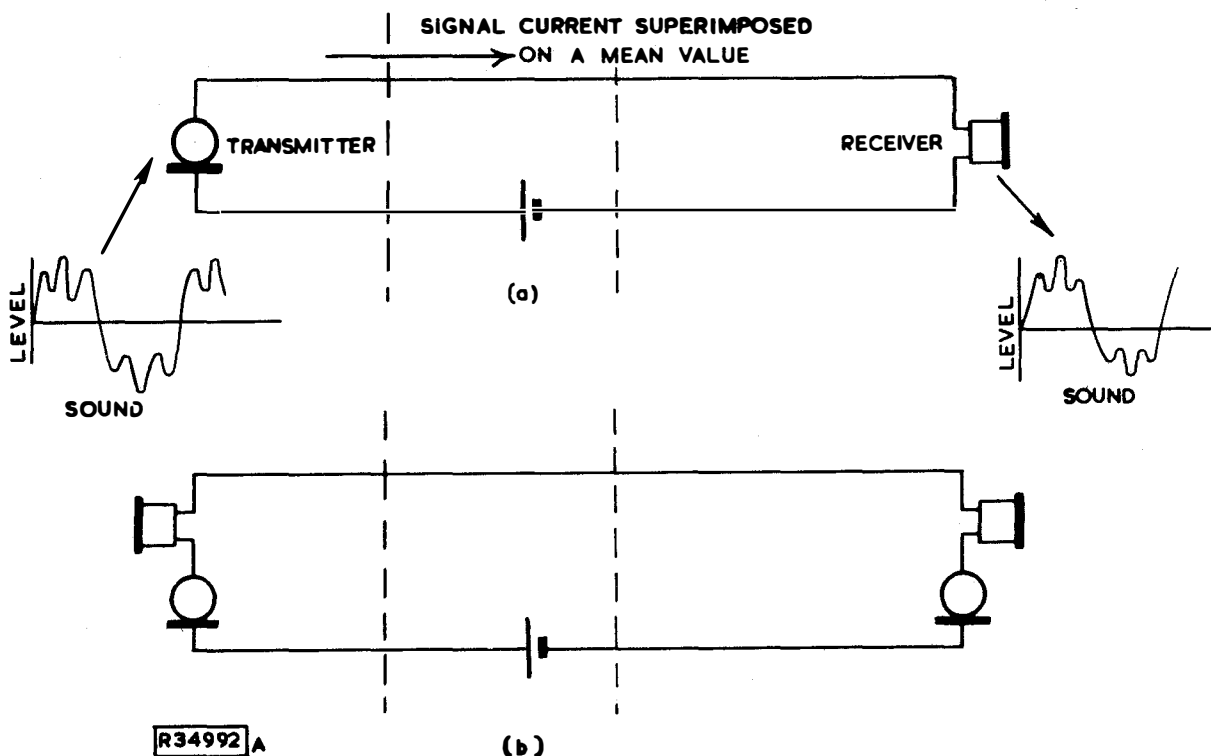

Fig. 1  
2.

The circuits shown in Fig. 1 have certain disadvantages. As the distance between the two stations is increased, so also will the resistance of the connecting line be increased. Consequently, to maintain the same transmitter output, the e.m.f. of the battery must be increased in order to keep the transmitter energizing current at the same value. Apart from the difficulty of adjusting the battery voltage for each individual line, a limit is soon reached when it becomes uneconomical to provide the required number of cells. There are two solutions to the problem, namely:-

(a) Provision of a local circuit at each station for the transmitter and battery, the resistance of this circuit being independent of the length of the line; this is referred to as a Local Battery system.

(b) Provision of a high-voltage battery at some central point to serve all the transmitters on an exchange; this is known as a Central Battery system.

### Local Battery System

A simple circuit diagram of two local battery telephones connected by a pair of wires is shown in Fig. 2. The transformer, generally termed an induction coil, provided in this telephone circuit performs the following functions:-

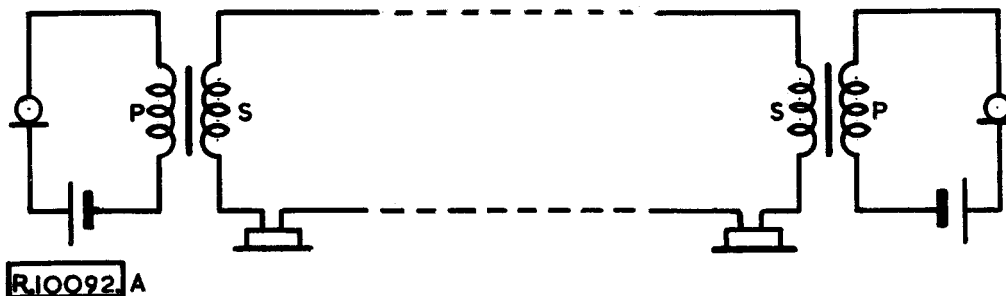

Fig. 2

(a) Provides a local circuit of low resistance for the transmitter, thus enabling adequate feeding current to be obtained from a low voltage battery. In practice it is usual to employ two primary cells connected in series, i.e. 3 volts.

(b) Isolates the receiver from the path of the transmitter feeding current. It is undesirable to have direct current flowing through the receiver because it may produce a magnetic field in opposition to that of the permanent magnet.

(c) Matches the impedance of the transmitter circuit with that of the line to ensure maximum sending efficiency. The theory of impedance matching is not considered in this pamphlet, but the following may be accepted without proof. When a direct or alternating source of e.m.f. is used to supply current to an external load, the power dissipated in the load will be a maximum when the load impedance is equal to the internal impedance of the source. The source and external load are then said to be "matched". If this condition does not arise naturally, the load impedance presented to a source of alternating e.m.f. may be varied by means of a matching transformer, since primary impedance =  $\left(\frac{\text{primary turns}}{\text{secondary turns}}\right)^2 \times$  secondary impedance.

The required load impedance may therefore be obtained by a transformer with a suitable turns ratio.

The circuit arrangement of a type of local battery, L.B., telephone in common use is shown in Fig. 3. The induction coil has three windings and acts as an auto transformer when speech is both transmitted and received. The spring-sets which are actuated by the removal of the telephone handset, that is the moulding

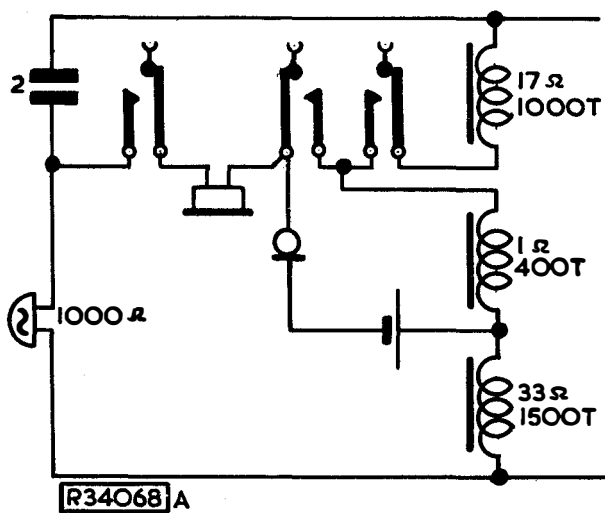

Fig. 3

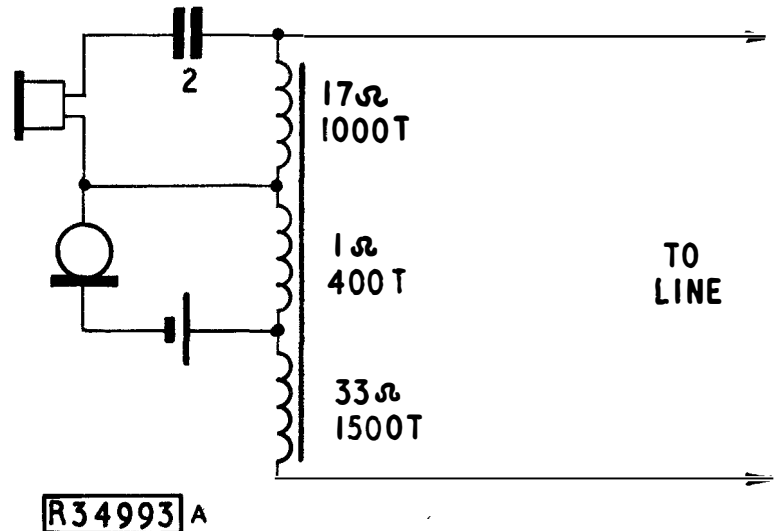

Fig. 4

which houses the transmitter and receiver, disconnect the local battery circuit and ensure that only the bell coils in series with the capacitor, bridge the line when the telephone is normal. The capacitor is included in the bell circuit to comply with the 'loop-calling' disconnexion-clearing' line signalling conditions. For consideration of the transmission of speech the circuit of Fig. 3 can be rearranged as shown in Fig. 4. When the transmitter is spoken into, the resultant alternating currents that flow in the coil which is directly associated with the transmitter, that is the 1 ohm 400 turn winding, induce aiding voltages in each of the three windings. Thus, because of the auto transformer action of the induction coil, the voltage developed across the 400 turn winding is stepped up by the ratio  $1000 + 400 + 1500$  to 400, i.e. 7.25 to 1, before being applied to the line.

The impedance ratio is equal to the square of the turns, or voltage, ratio consequently there is a 52.5 to 1 step up impedance ratio between the transmitter circuit and the line. Such a high ratio is required because the transmitter circuit contains only the impedance of the transmitter.

Received speech currents flow in all the windings but the receiver is actuated by currents caused by the voltage induced in the 1000 turn winding. Thus the voltage developed across the three windings by the received currents is stepped down by the ratio  $1000 + 400 + 1500$  to 1000, i.e. 2.9 to 1 before being applied to the receiver. The 2.9 to 1 voltage ratio means that there is an 8.4 to 1 impedance step down ratio between the line and receiver circuit.

In Post Office practice the telephone circuit shown in Fig. 3 is formed by interconnecting a Telephone No. 196 L.B. and a Bell Set No. 31, or it is contained within the combined telephone and bell set, the telephone No. 396.

The circuit of a subscriber's telephone installation in a magneto exchange area is shown in Fig. 5 (appended). The circuit is, except for the generator, identical with that given in Fig. 3. The hand operated generator develops low frequency alternating current and is used for signalling the exchange. Immediately the generator handle is turned the associated spring-set operates and disconnects the telephone from the generator, thereby ensuring that the alternating current is applied only to the line. When normal the generator is disconnected from the line.

### Central Battery System

The elementary circuit of the connexion between two central battery telephones is shown in Fig. 6. The coil and battery are situated at the telephone exchange, the coil is particular to the connecting circuit but the battery is common to all the circuits. If the transmitter, A, of circuit 1 is spoken into, the greater portion of the alternating currents so generated will flow through the receiver of circuit 2. Similarly alternating currents generated by the transmitter, A, in circuit 2 will flow through the receiver of circuit 1. If the coil, which has a

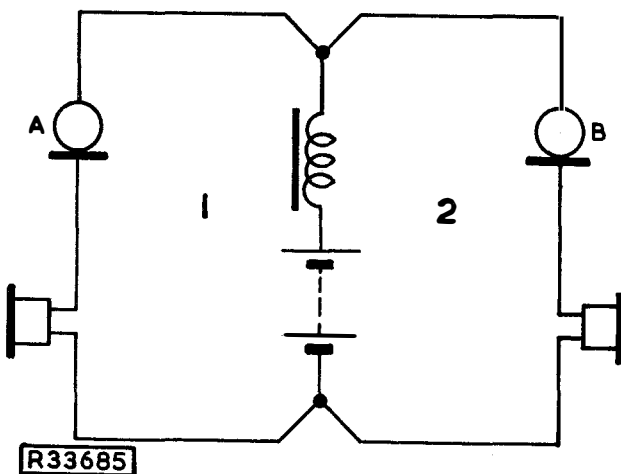

Fig. 6

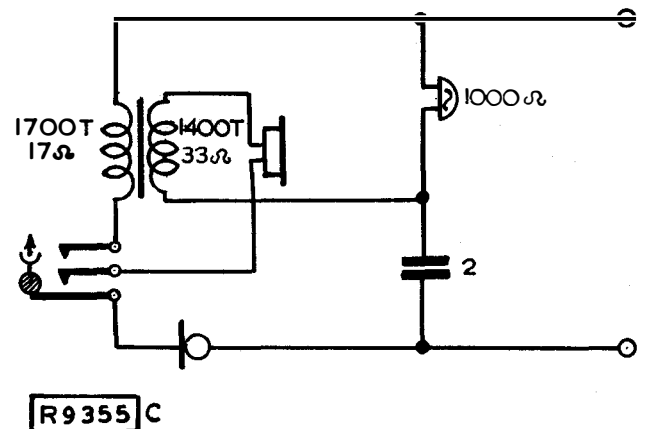
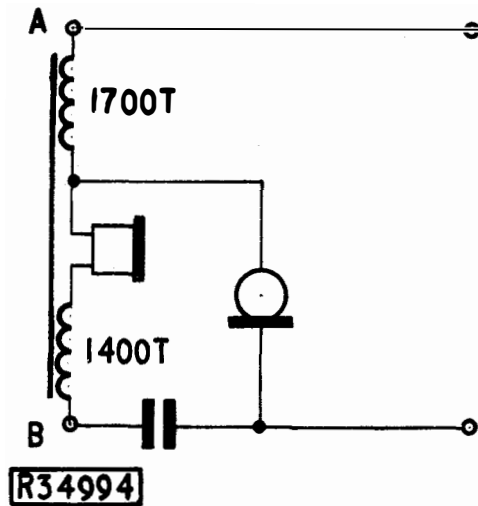

Fig. 7

high impedance to speech frequency alternating currents, is not included in the circuit by far the greater proportion of the alternating currents generated by each of the transmitters would flow through the low resistance path offered by the battery instead of the appropriate receiver. The voltage of the battery is determined by the exchange switching system, 22 or 40 volt is general for manual systems and 50 volt is standard for automatic systems.

The circuit of an early type of C.B. telephone is shown in Fig. 7. The circuit is different from the L.B. telephone, Fig. 3, because provision has to be made for connecting the transmitter in series with the central battery and isolating

the receiver from the direct current. For the purpose of considering the transmission of speech, the circuits can be drawn as shown in Fig. 8, the magneto bell offers a very high impedance to the speech and consequently can be neglected. The



capacitor can also be neglected because of its low reactance at speech frequencies, but is included to show how it isolates the receiver from direct current. It should be noted that by connecting a particular line wire to a particular terminal of the telephone the direct current would oppose the permanent magnet in the receiver. The presence of the capacitor is, however, still necessary to ensure that there is the maximum possible flow of direct current through the transmitter and consequently the maximum possible alternating current output. In modern telephone circuits it can be considered that the main purpose of the capacitor is to block any path for direct current other than that through the transmitter.

Fig. 8

When the transmitter is spoken into, alternating voltages are developed across it, and consequently alternating currents are caused to flow in the 1700 and 1400 turn windings of the induction coil. The currents in the 1700 turn winding, however, are small and for the purpose of this simple explanation may be neglected. The windings of the induction coil are connected in series aiding, and consequently the voltage induced between the points A and B, Fig. 8, by the alternating current in the 1400 turn winding is in the ratio 1.4 to  $(1.4 + 1.7)$  to that developed across the 1400 turns. Thus the induction coil acts as an autotransformer, and the voltage applied to line, i.e. points A and B, is approximately 2.2 times that developed by the transmitter in the 1400 turn winding. It follows that the impedance matching ratio between the transmitter and line circuits is approximately 1 to 4.8.

When speech currents are received the induction coil acts as a simple transformer having a 1.7 to 1.4 step down turns ratio. The low impedance path offered by the transmitter to the received currents effectively short circuits the 1400 turn winding and receiver. Consequently the speech currents which actuate the receiver are caused by the voltage induced in the 1400 turn winding by the received current in the 1700 turn winding. The impedance matching ratio between the line and the receiver circuits is approximately 1.48 to 1.

#### PRINCIPLE OF THE ANTI-SIDE TONE INDUCTION COIL CIRCUIT

##### Introduction

Sidetone, which may be defined as the reproduction in a telephone receiver of sounds picked up by the associated transmitter, causes the subscriber to lower his voice; presumably this is because by hearing himself well in his own receiver he has the subconscious impression that the distant subscriber can hear him well also. Although it is certainly not desirable for a subscriber to shout into the transmitter, a tendency to speak in a voice lower than normal is to be avoided.

Sidetone has the following bad effects:-

(a) It lowers the transmitting efficiency of the instrument by wasting power in the receiver circuit.

(b) It lowers the apparent transmitting efficiency by causing the speaker to lower his voice.

(c) It lowers the overall receiving efficiency by producing ear fatigue. On the other hand a small amount of sidetone is desirable in order to avoid the impression of speaking into a 'dead' telephone.

Room noise sidetone may be reduced by stopping extraneous noise and reducing reverberation in the room containing the telephone. The circuit arrangement of the telephones already described in this pamphlet are such that a portion of the output from the transmitter is reproduced in the associated receiver. Thus the production of sidetone is inherent in the circuits.

The method that became standard to suppress the sidetone inherent in the early type of C.B. telephone circuit is shown in Fig. 9. An additional induction

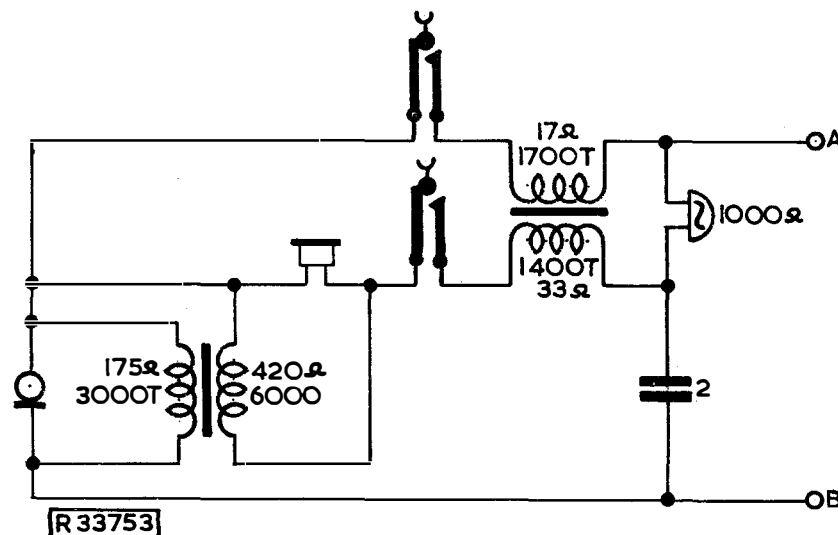

Fig. 9

coil is introduced into the circuit and connected so that it introduces speech currents in the receiver which oppose those caused directly by the transmitter. With average line conditions the opposing currents reduce the sidetone to a tolerable level.

In B.P.O. practice the telephone circuit shown in Fig. 9 is formed by interconnecting a Telephone No. 162 C.B. and a Bell Set No. 25.

In telephone circuits of modern design the separate anti-sidetone coil has been abolished and additional windings added to the original induction coil. The new coil is termed an "anti-sidetone induction coil", and telephones so fitted are consequently referred to as A.S.T.I.C. telephones. It should be noted that the induction coil by itself does not possess anti-sidetone qualities, these properties are established by the circuit which includes such an induction coil.

The modern subscribers telephones used by the B.P.O. have a transmission circuit based on the following observed fact:-

It is only possible for the transmitter, receiver, and line of a telephone circuit to be interconnected so that each is electrically matched to the remainder of the circuit, thus ensuring maximum transfer of sent and received power, when an additional power consuming impedance is included in the circuit. The power consuming impedance is termed a 'balance'.

The basic circuit arrangement is that shown in Fig. 10. The sense of the three windings of the induction coil and the electrical characteristics of the other components are such that, ideally

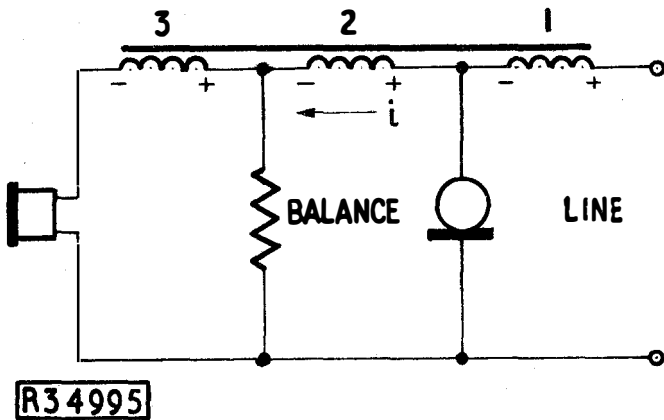

Fig. 10

(a) when transmitting, the output power is shared only between the line and balance, and

(b) when receiving, the output power from the line is shared only between the receiver and the transmitter.

The coil is wound such that a current in one winding will induce voltages of similar polarity in all the windings as indicated in Fig. 10.

A simplified treatment of the circuit operation and the factors which govern the electrical characteristics of the components will now be considered.

### Transmitting

When the transmitter is spoken into, the alternating voltages developed across it cause alternating currents to flow as indicated in Fig. 11. In practice a low resistance transmitter is used in order to keep the resistance of the signalling path low, and the current in winding 2 produces the greater ampere-turns product

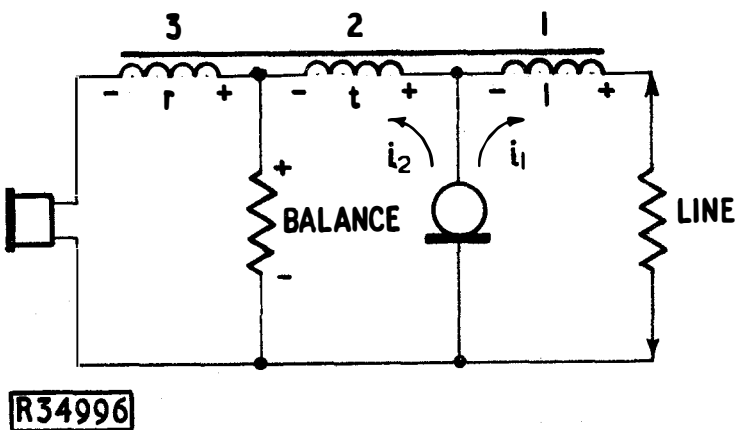

Fig. 11

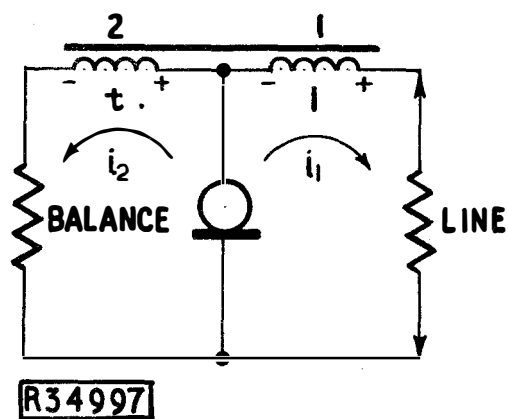

Fig. 12

and controls the direction of the flux in the core. The sense of the instantaneous currents and the induced voltages may be considered as shown in Fig. 11.



For the condition of 'no sidetone' there must be no flow of alternating current in the receiver. The condition is obtained by arranging that the turns ratio of winding 3 to the other windings results in an induced voltage across winding 3 which is equal and opposite to that developed across the balance impedance by  $i_2$ . The receiver is then subjected to two equal and opposite alternating voltages, hence there is no flow of current in the receiver.

When the no-sidetone condition exists the transmitting circuit can be considered as that shown in Fig. 12. The current  $i_1$  can be neglected because  $i_1$  controls the flux in the core, thus the total voltage induced in windings 1 and 2 by  $i_2$  is applied to a load which consists of the balance impedance in series with the line impedance. The output from the transmitter is, therefore, shared between the balance and the line, the division of the power will be considered later in this pamphlet.

### Receiving

The source of received speech can be considered as an alternating voltage in series with the impedance of the line as shown in Fig. 13. The current,  $i_1$ , which is caused to flow through winding 1 and the transmitter by the alternating voltage, induces aiding voltages in windings 2 and 3 as indicated in Fig. 13.

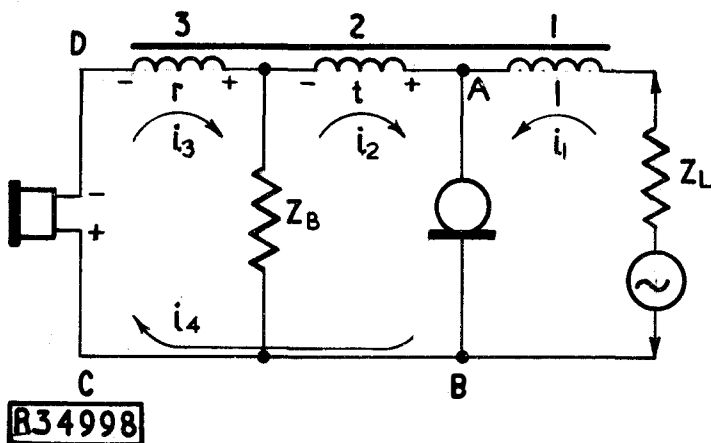

Fig. 13

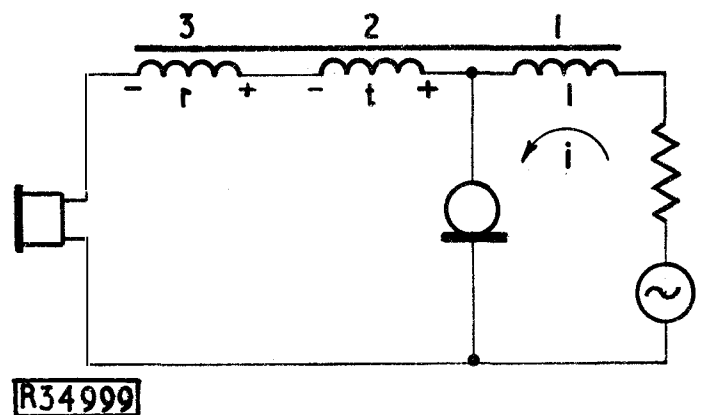

Fig. 14

The induced voltages could cause the flow of the three currents,  $i_2$ ,  $i_3$  and  $i_4$  as indicated in Fig. 13. It is a feature of the circuit however, that when it is balanced for no-sidetone and the receiver is of a suitable impedance,

(a) the voltage developed across the receiver by  $i_4$  is equal to that which is induced in winding 3 by  $i_1$ , but of opposite polarity as indicated in Fig. 13.

(b) there is no flow of current in the balance  $Z_B$ , i.e. currents  $i_2$  and  $i_3$  do not flow.

The conditions (a) and (b) mean that the power received from the line is shared only between the receiver and the transmitter.

The receive circuit can be considered as that shown in Fig. 14 because there is no power expended in the balance. The voltages induced in windings 2 and 3 are applied to a load consisting of the receiver in series with the transmitter, and the line is coupled to the circuit by a turns ratio of 1 to  $(r + t)$ , where 1,  $r$  and  $t$  is the proportionality of the turns as indicated in Fig. 13.

Design Considerations

In practice a telephone has to work in an existing network of lines the impedances of which range over widely spaced limits. Consequently as the condition of no-sidetone or a fixed value of sidetone requires a fixed relationship between the impedances of the line and the balance, it is not practicable to design the circuit to have a predetermined sidetone condition on all lines. Thus one problem in the design of the circuit is to keep the sidetone within tolerable limits over the usual range of speech frequencies for the line conditions met in practice.

For the telephone circuit to have a high transmission efficiency it must be designed so that the transmitter circuit impedance is matched to its load impedance, and the ratio of the power expended in the line to that expended in the balance is high. The ratio is known as the Y ratio. Under ideal conditions and allowing for the auto-transformer action of the induction coil, the impedance of the load on the transmitter in the basic A.S.T.I.C. telephone circuit is

$$\left(\frac{t}{t+1}\right)^2 Z_L + \left(\frac{1}{t+1}\right)^2 Z_B$$

where  $Z_L$  = impedance of the line  
 $Z_B$  = impedance of the balance  
 1 and t = proportionality of the turns  
 of windings 1 and 2, Fig. 11

The two components of the load impedance and consequently the Y ratio can, therefore, be adjusted only by the alteration of the turns ratio 1 to t and/or the impedance of the balance. In practice the values of t and  $Z_B$  are chosen to simultaneously match the transmitter to an average load and to give the required Y ratio. It is a basic property of the A.S.T.I.C. telephone circuit, however, that if the no-sidetone and receive conditions exist as previously described, then

$$Y = \frac{\text{Trans. power to line}}{\text{Trans. power to balance}} = \frac{\text{Received power to transmitter}}{\text{Received power to receiver}}$$

Thus the optimum Y ratio is 1, and if it is increased beyond this figure the receiving efficiency is decreased. Consequently unless the physical design of the receiver is an improvement on that used in existing telephones, any improvement in the transmitting efficiency caused by the circuit arrangements results in a decreased receiving efficiency.

If it is assumed that there is no saving in the manufacturing costs of a new telephone, economic advantage is gained only if the existing maximum permissible length of a line can be increased. Such a condition can exist only when both the transmit and receive features of the telephone are improved. Consider a new type of telephone which has a transmitting and receiving performance which is x and y units respectively better than the existing standard instrument. The transmission improvements over an existing connexion are,

New telephone transmitting to existing	=	+ x units
New telephone receiving from existing	=	+ y units
New telephone transmitting to new	=	x + y units
New telephone receiving from new	=	x + y units

Assuming that the lower limit of transmission performance allowable on a connexion between existing telephones is 0 units, then the length of the connexion when using

new instruments at each station can be increased to introduce an additional loss of  $x + y$  units. However, when the new telephone is to work with an existing instrument, the loss introduced by an increase in the length of the line must not be greater than the lesser of  $x$  and  $y$ . Thus there is no economic advantage if only the transmitting or receiving circuit is improved, but maximum advantage is gained when both circuits are improved by the same amount.

#### PRACTICAL A.S.T.I.C. TELEPHONE CIRCUITS

The present standard C.B. exchange subscriber's telephone, the No. 332, has a transmission circuit based on the anti-sidetone induction coil. The telephone No. 332 is termed a combined set because the telephone and bell set are contained in the same case. The previous standard telephone, the No. 232, has a similar transmission circuit but has the magneto bell and d.c. blocking capacitor in a separate case.

The circuit of the telephone No. 332 has been modified to suit the requirements of shared service lines, and the modified circuits have been given numbers in the 300 series. The requirements of shared service lines are discussed later in this pamphlet.

It should be noted that the telephone No. 396 which is used on C.B.S. and Magneto subscribers' lines is not an A.S.T.I.C. circuit; the transmission circuit is similar to that shown in Fig. 4.

Research into the design of telephone receivers has produced a receiver, the rocking armature type, which is more sensitive and has a better frequency response than the type used in the 300 series telephones. It has been found, however, that there is little chance in the immediate future of improving the output power of the carbon granule type of transmitter, the more likely improvements being related to frequency response and distortion. In 1955 the B.P.O. decided to proceed with the design of a new telephone, the 700 type, using the rocking armature receiver but retaining the existing standard type of carbon granule transmitter, and obtaining a balanced increase in transmission by re-design of the circuit.

The original 700-type telephone was contained within a 300-type telephone case but had a handset of new design. Subsequently an instrument of a new physical design and shaped to satisfy modern tastes was introduced, and designated the Telephone No. 706.

The Telephone No. 332

The electrical connexions of a Telephone No. 332 suitable for use on an automatic exchange subscriber's line are shown in Fig. 15; the circuit changes which are necessary when the telephone is used on a manual exchange line are indicated in the figure. A photograph of the telephone is shown in Fig. 16 (appended).

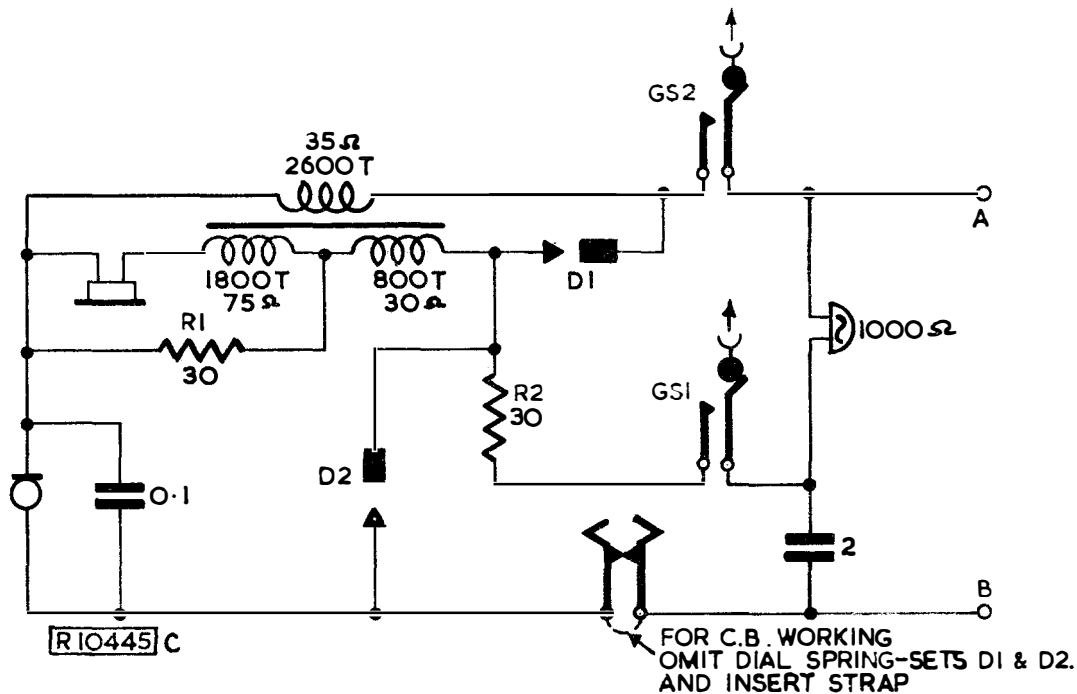

Fig. 15

The circuit arrangements allow for a 3-way connecting cord to be used between the components of the circuit contained within the body of the telephone and the inset transmitter and receiver which are housed in the handset. The components contained in the body are mounted on a metal plate as shown in Figs. 17 and 18 (appended); it should be noted that the two 30 ohm resistors are in the form of non-inductive windings on the induction coil.

The 0.1 capacitor is connected in parallel with the transmitter to prevent the demodulation of radio frequency currents that may be induced in the telephone line in certain districts. The demodulation effect will produce extraneous currents in the receiver circuit and consequently cause interference to the telephone user.

Signalling circuits

The ringing signal circuit consists of the 1000 ohm magneto bell connected in series with the 2  $\mu$ F capacitor directly between the A and B-wires, Fig. 15.

The loop calling signal circuit is completed when the gravity switch contacts GS1 and GS2 operate, i.e. when the handset is removed from the telephone. The loop is completed from the A-wire via GS2, 35 ohm winding of the induction coil, the transmitter, and dial pulse springs to the B-wire. When the telephone is normal the 2  $\mu$ F capacitor is charged to the exchange battery voltage, and contact GS1 operated completes a discharge path for the capacitor via the transmitter. Contact GS1 is designed to operate before GS2 and so complete the discharge path before the receiver circuit is completed, thus preventing an objectionable click in the receiver when the handset is removed.

The disconnexion clearing signal is created by contact GS2 when the handset is replaced.

### Dialling circuit

When the dial is moved off-normal contacts D1 and D2 operate, that is make, and form a non-inductive pulsing circuit. Contact D2 short circuits the variable resistance of the transmitter and completes a spark quench circuit across the dial pulse springs, it should be noted that the bell circuit capacitor is used in this circuit. Contact D1 short circuits the induction coil windings and the receiver, thus preventing clicks in the receiver during dialling. The 30 ohm resistor in the spark quench circuit is also connected across the bell to prevent its operation during dialling. The circuit conditions during pulsing are shown in Fig. 19.

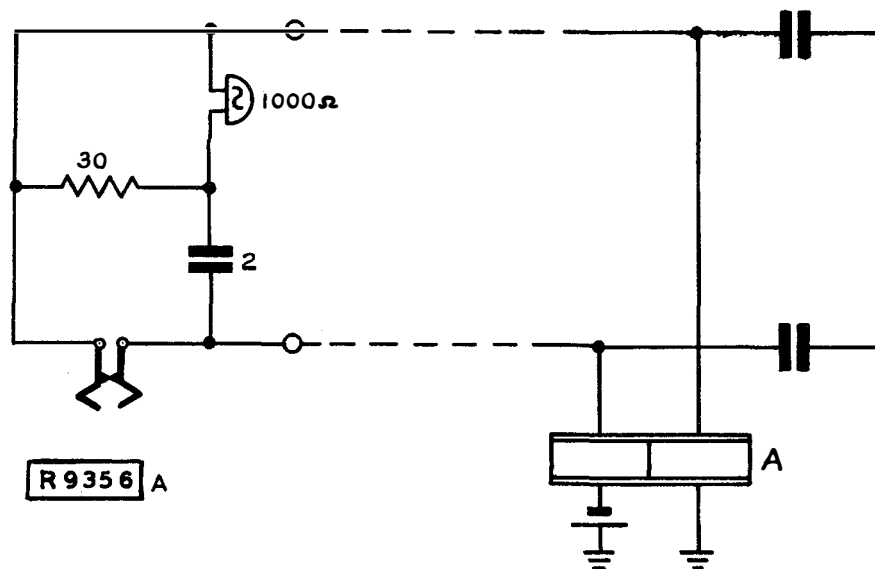
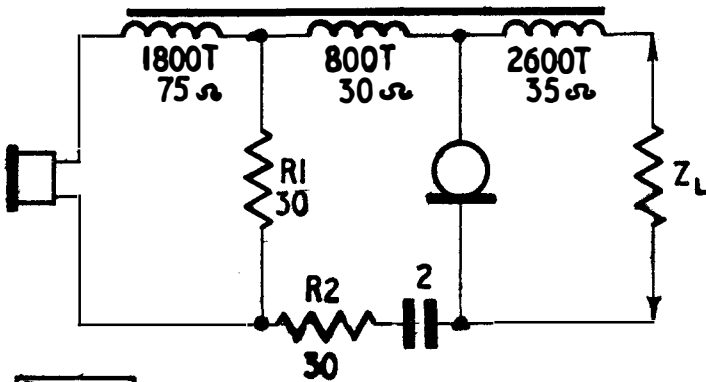

Fig. 19

Transmission circuit

Making use of the fact that, in a circuit the order in which elements are connected in series may be changed without affecting the working of the circuit; the transmission circuit of the telephone No. 332 can be represented as shown in Fig. 20. The impedance of the bell at speech frequencies is such that its shunting effect on the circuit can be ignored. The impedance of the  $2 \mu\text{F}$  capacitor can be ignored at all but the lowest speech frequencies, a larger capacitance would be desirable but is ruled out because of component size and cost. R2 is so positioned in the circuit to enable the capacitor to be used in both the bell circuit and the pulse spring spark quench circuit, thereby saving one capacitor.



R35000

Fig. 20

The transmitting and receiving conditions are similar to those already discussed for the A.S.T.I.C. telephones; the effect of R1 and R2 however require some explanation. The balance, assuming that the impedance of the capacitor can be neglected, is composed of R1 in series with R2, consequently the Y ratio is determined by their combined resistance in conjunction with the turns ratio of the induction coil. Thus there is no decrease in transmitting efficiency because of the presence of R2. Assuming that the circuit is balanced for a condition of no-sidetone, there is no flow of current in R1 when power is received from the line. In the basic circuit the received power is shared between the transmitter and receiver in the Y ratio, in the receive circuit of the telephone No. 332 however, the power is divided between the transmitter and the combination of R2 and the receiver. The ratio of R2 to the impedance of the receiver is low and consequently the loss of receive efficiency is low.

The turns ratios of the induction coil are such that, under balanced conditions, the load impedance presented to the transmitter is very nearly

$$\frac{1}{18} Z_L + \frac{1}{1.7} Z_B$$

where  $Z_L$  = impedance of line, and

$Z_B$  = impedance of balance

and results in a Y ratio of approximately 1. The impedance presented to the line is equal to

$$Z_R + 4 \cdot Z_T$$

where  $Z_R$  = impedance of the receiver, and

$Z_T$  = impedance of the transmitter.

The Telephone No. 706

The Telephone No. 706, Fig. 21 (appended) includes a number of new mechanical features, and has been designed so that with the addition of auxiliary units it can meet all the requirements for a table telephone. For example, by the addition of suitable units the basic telephone can easily be made suitable for automatic and manual shared service working, or for C.B.S. No. 1, C.B.S. No. 2 and Magneto working, i.e. a local battery telephone suitable for C.B.S. No. 1, C.B.S. No. 2 and Magneto working.

The electrical connexions of the basic telephone are shown in Fig. 22. When conventional wiring methods are used the components contained within the body of the telephone are mounted on a tough polystyrene pressing which forms the base of the telephone. Some Contractors, however, use the printed wiring technique, the circuit is then printed on a resin bonded board which is mounted with the other components on a pressed steel base-plate. In both systems the dial is mounted on the base of the telephone and wired directly into the circuit. Because the dial is mounted on the base the telephone can still be used when the case is removed,

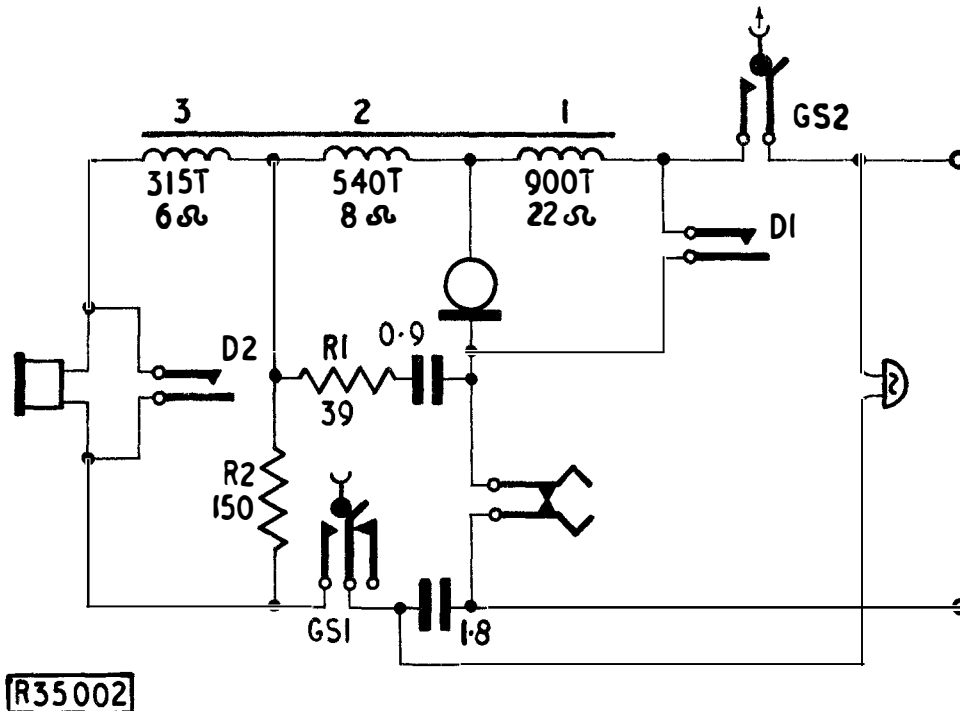

Fig. 22

such an arrangement is useful for maintenance purposes. The numerals and the letter equivalents are engraved on a ring which surrounds the dial, the number ring on the dial being engraved only with the numerals. The letter Q is associated with the digit 0 in anticipation of future subscriber trunk dialling requirements. The gravity switch is of a new design to suit the lightweight handset, and the associated springs have palladium contacts and full length twin tongues for reliability. A photograph of the telephone with the case removed is shown in Fig. 23 (appended).

To obtain an improved transmission performance, the induction coil has a closed magnetic circuit, and the balance-circuit resistors are not wound on the core as in the earlier type of coil. The use of separate resistors in the balance-circuit is convenient because it gives flexibility to the design of the circuit pattern. The transmission circuit requires a capacitor in the balance circuit, and for manufacturing convenience this capacitor is housed in the same container as the d.c. blocking capacitor. The size of the container is limited by the space available in the telephone and, as will be explained later, the values of the capacitors are a compromise to meet transmission and signalling requirements.

The receiver and the transmitter are of the inset type and are housed in the lightweight handset, the 'handle' of which follows a curve of constant radius. A 4-way connecting cord is used to enable the dial spark quench circuit to be formed from components necessary for the transmission circuit.

Signalling circuit

The ringing signal circuit is formed by the 1000 ohm magneto bell connected in series with the 1.8  $\mu\text{F}$  capacitor directly between the A- and B-wires, Fig. 22. It should be noted that in order to use the 1.8  $\mu\text{F}$  capacitor in both the ringing signal and transmission circuits direct current flows through the receiver when the telephone is in use. The direct current path includes the 1000 ohm resistance of the bell, consequently the value of the current is very small and its effect on the receiver sensitivity can be ignored. The current does, however, 'wet' the gravity switch contacts GS2, which otherwise would carry only speech currents and possibly give rise to faults.

The loop calling signal is completed by the gravity switch contacts and is formed by the contact GS2, 22 ohm winding 1, the transmitter and dial pulse springs. When the handset is lifted contact GS1 operates first to complete a discharge path for the 1.8  $\mu\text{F}$  capacitor.

The disconnexion clearing signal is created by contact GS2 when the handset is replaced.

Dialling circuit

The dial off-normal contact D1 prepares the low resistance pulsing path and the pulse spring spark quench circuit, and off normal contact D2 short circuits the receiver. The circuit conditions during pulsing are shown in Fig. 24(a), and a simplified version of the circuit, assuming the transmitter to have a resistance of 80 ohms, is shown in Fig. 24(b). An assessment of the effects of the circuit on

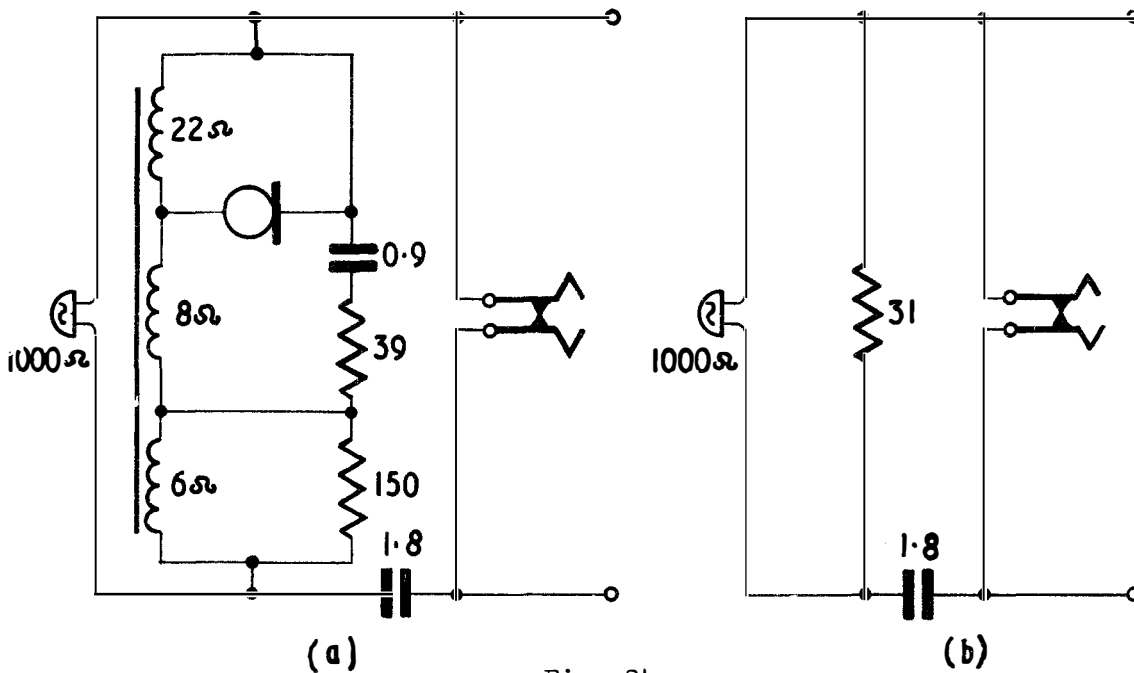

Fig. 24

R35004



pulse shape and ratio is complicated by the presence of inductance in the spark quench circuit, but it has been found that the effects are very similar to those of the resistance-capacitance circuit used in the Telephone No. 332. The bell is prevented from operating during dialling by the 31 ohm shunt.

### Transmission circuit

The transmission circuit is shown in Fig. 25. It has already been illustrated that to gain an economic advantage from a new telephone both the receiving and transmitting characteristics must be improved, and that maximum advantage is gained when both characteristics are equally improved. Only the receiver of the Telephone No. 706 has been improved, consequently if the circuit had been designed to have a Y ratio of 1, only the receive characteristic would be improved and no economic advantage gained. If, however, the Y ratio is increased the transmitting characteristic is improved but the gain due to the improved receiver is reduced; this feature of the A.S.T.I.C. circuit has already been discussed in this pamphlet. In the transmission circuit of the Telephone No. 706 the Y ratio has been increased to 3.3, thereby reducing approximately by a half the maximum gain in receive performance possible with the new receiver, but increasing the transmitting characteristic. The overall result is that the increase in Y ratio, in conjunction with other circuit improvements, causes an equal improvement in both the receiving and transmitting characteristics thereby giving the maximum economic advantage.

In practice the Telephone No. 706 allows for an increase of line length equivalent to a loss of 4 decibels (reference 1 mW in 600 ohms) when connected to a Telephone No. 332, and consequently an increase of length equivalent to 8 decibels when connected to a similar telephone. The existing network consists, of course, of both types of telephone consequently the economic advantage is the increase of line length equivalent to 4 decibel.

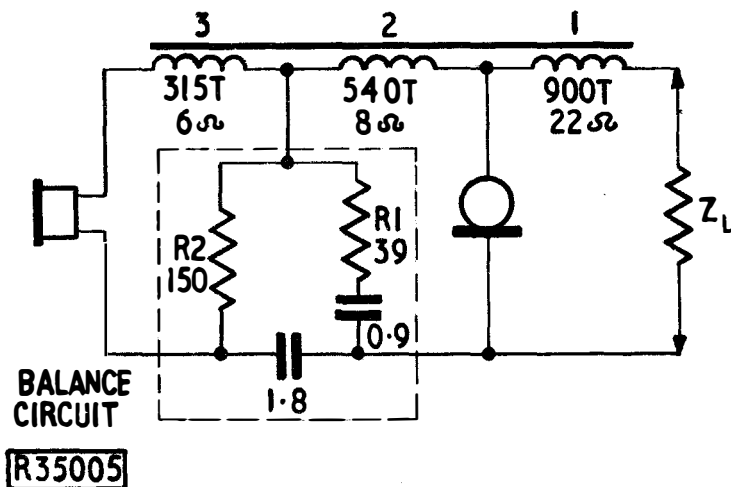

Fig. 25

is included in the balance; the value of this capacitor has been reduced from that used in previous circuits to enable the 1.8  $\mu\text{F}$  and 0.9  $\mu\text{F}$  capacitors to be housed in one can of a size suitable to fit the space available.

The improved efficiency of the transmitting and receiving features increases the level of the sidetone, and it is likely that this will cause a subscriber to lower his voice and consequently offset the transmission improvements. The circuit is, therefore, designed to have a high degree of sidetone suppression over a wide range of line conditions. The complexity of the balance network necessary to give the required suppression is largely governed by the quality of the induction coil. In the Telephone No. 706 the quality of the coil is improved by the use of a closed magnetic path formed from laminations of high grade silicon-iron, and this allows the use of the relatively simple resistance-capacitance balance shown in Fig. 25. It should be noted that the d.c. blocking capacitor

The induction coil winding ratios necessary to meet the chosen Y ratio and the impedances of the line and transducers are:-

$$\text{winding 1 to winding 2} = 1.67$$

$$\text{and winding 1 to winding 3} = 2.86$$

### Local battery adaptor

The telephone circuit may be converted to local-battery working by the addition of a choke coil, a 'make' gravity switch spring unit, and a 3 volt battery connected as shown in Fig. 26. The 15 ohm choke coil provides a relatively low resistance path for the transmitter feed current but a very high impedance path to the generated speech currents, therefore its presence has negligible effect on the flow of speech currents in winding 2. The gravity switch unit GS3 ensures that the circuit for the local battery is disconnected when the telephone is not in use. When the telephone is used in C.B.S. No. 1 areas the two bell coils are connected, in parallel, thereby reducing the combined resistance to 250 ohms, and the bell is connected directly to earth at point X in Fig. 26; there is no direct connexion between the B-wire and the bell circuit. In C.B.S. 2 and 3 and Magneto areas the bell coils are connected in series and point X is connected directly to the B-wire.

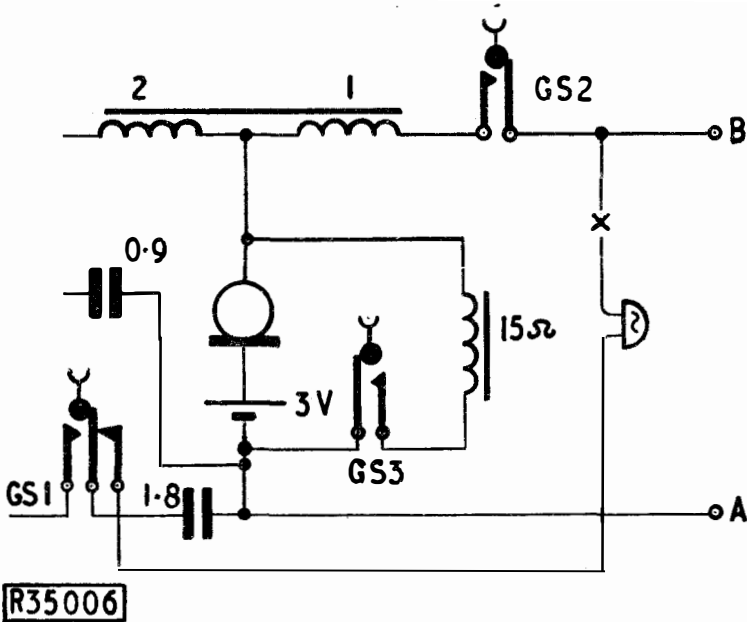

Fig. 26

### Shared service adaptors

The adaption of the Telephone No. 706 to shared service working is dealt with later in the pamphlet.

### Regulator circuit

Subjective tests have shown that the increased sensitivity of the Telephone No. 706, whilst permitting the use of longer lines, is an embarrassment to subscribers on calls over short lines. Such embarrassment can be prevented by,

- (i) providing the telephones connected to short lines with a unit designed to reduce the sensitivity by a predetermined amount.
- (ii) providing all telephones with a regulator which reduces the sensitivity by an amount governed by the value of the line current, i.e. an automatic regulator.

The method given in (i) is not practicable because of the additional work involved in the provision of each telephone. In practice each telephone is fitted with an automatic regulator operating as outlined in (ii).

Basically the regulator is a network of resistors and selenium rectifiers which effectively introduces a low d.c. resistance in series with the transmitter, an a.c. shunt path across the transmitter, and an a.c. shunt path across winding 2. The regulator circuit is contained within the broken lines in the complete transmission circuit of the Telephone No. 706 which is shown in Fig. 27

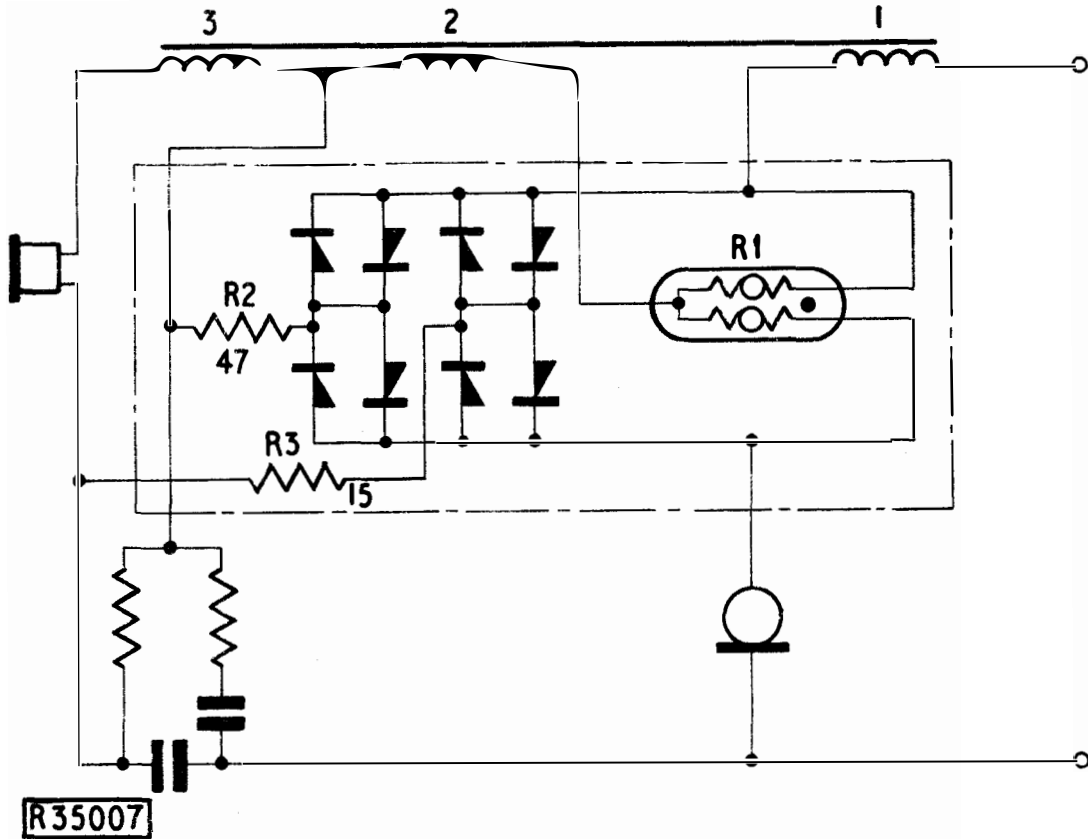

Fig. 27

An appreciation of the operation of the regulator may be obtained by first considering the circuit element shown in Fig. 28. The potential developed across  $R_1$  by the transmitter feed current will have a polarity as indicated, and its magnitude will increase as the resistance of the line  $R_L$  decreases. If it is assumed that all

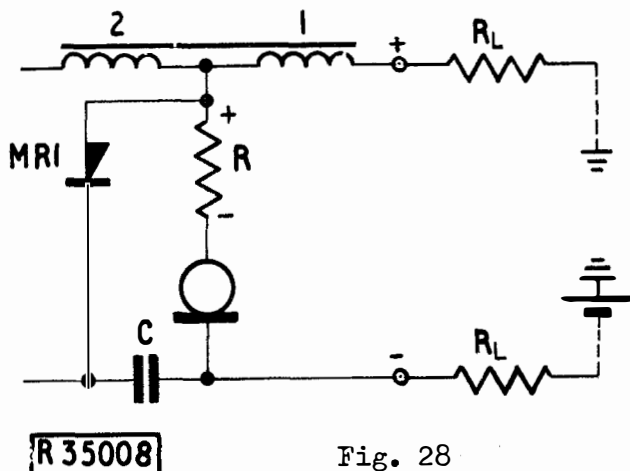

Fig. 28

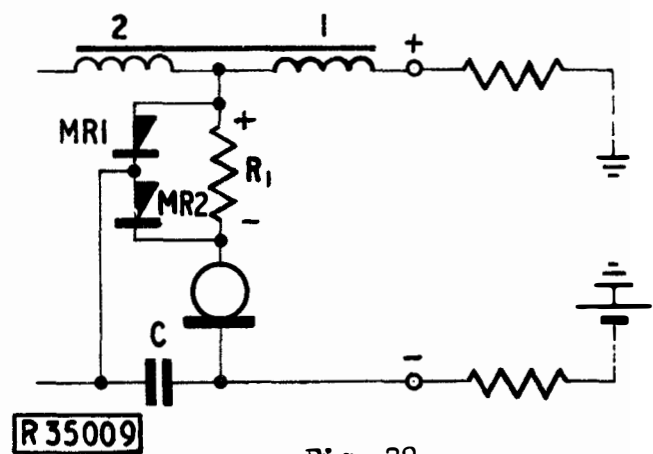

Fig. 29

lines have the same gauge conductor, the value of the positive bias potential on the rectifier increases as the length of the line decreases. Therefore as the length of the line decreases the forward resistance of the rectifier decreases and the impedance of the circuit  $R_1$ ,  $MR_1$  and  $C$  in shunt with the transmitter also decreases. The effect of the shunt is to divert a portion of the transmitter output from winding 2 and therefore decrease the output to line. The rectifier has a non-linear voltage/resistance characteristic and there is partial rectification of that part of the transmitter output which flows via the shunt, so giving rise to appreciable distortion. The inclusion of a second rectifier,  $MR_2$ , similarly biased and connected as shown in Fig. 29 obviates the noticeable distortion by causing both the positive and negative half cycles of the alternating component in the shunt to be equally distorted.

The basic circuit developed in the foregoing has several disadvantages, the more important being:-

(i) The value of  $R_1$  is independent of line current and must be of such a value that it does not seriously reduce the transmission efficiency when the value of  $R$  is high.

(ii) There is a linear relation between line current and the voltage drop across  $R_1$ , thus the bias potential will vary by the same ratio as the line current. In practice, however, a higher ratio of voltage change than current change is required to produce the necessary decrease in transmitting efficiency on short lines.

(iii) If direct current paths exist within the telephone circuit such that unequal currents flow in  $MR_1$  and  $MR_2$ , distortion will be caused by the resultant unequal characteristics of the rectifiers.

(iv) The regulator is made ineffective if there is a reversal of bias potential as would occur if there was a change of line polarity.

Taken in order, the disadvantages are overcome in practice as follows:-

(i) The resistance  $R_1$  is in the form of a tungsten-filament lamp which has a resistance/current characteristic such that its resistance increases as the current through it increases. Thus on long lines the resistance of  $R_1$  is low and has negligible effect on the transmission.

(ii) The characteristic of the lamp is such that when the line current is 76 mA the lamp resistance is 36 ohm, when the current falls to 30 mA however, the resistance is only 10 ohm. Therefore a bias voltage change of approximately 9 to 1 is obtained with a current change of about 2.5 to 1.

(iii) The resistance  $R_1$  is in two equal sections and the rectifiers are connected so that a Wheatstone bridge is formed as shown in Fig. 30. If it is assumed that, when equal current flows in each, the characteristics of  $MR_1$  and  $MR_2$  are similar the bridge is balanced and there will be no flow of direct current in the shunt path.

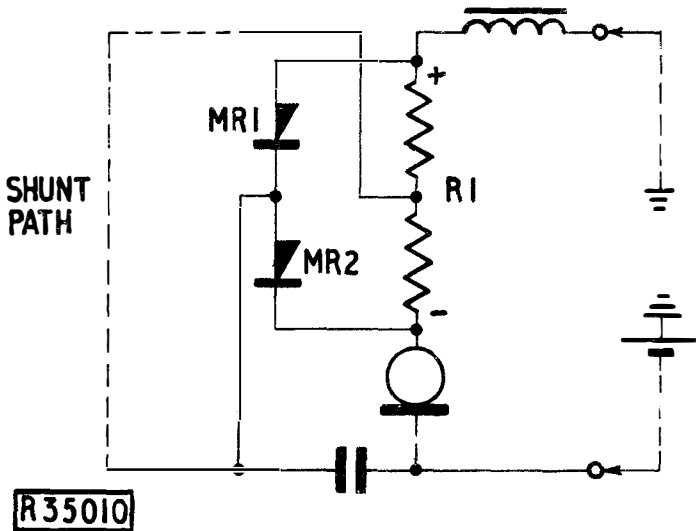

Fig. 30

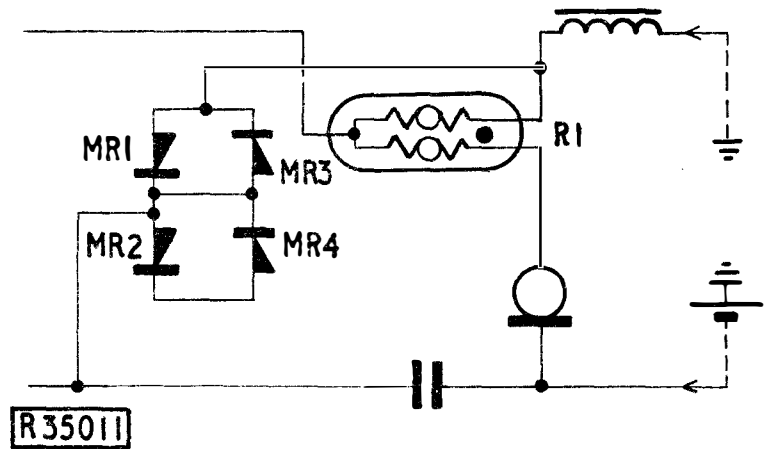

Fig. 31

(iv) An additional pair of rectifiers are connected in parallel with  $MR_1$  and  $MR_2$  as shown in Fig. 31, which also shows  $R_1$  as a resistance lamp. With the line polarity shown in the figure  $MR_1$  and  $MR_2$  are effective and  $MR_3$  and  $MR_4$  are subject to a negative bias such that they may be considered as a disconnection. A reversal of line polarity causes a reversal of bias conditions on the rectifiers and  $MR_3$  and  $MR_4$  are then effective and  $MR_1$  and 2 are biased negatively.

For simplicity only the shunt path on the transmitter has so far been considered. The loss on receiving is obtained by shunting winding 2 of the induction coil, such an arrangement requires less components than directly shunting the receiver, and is effected by connecting a second set of rectifiers across  $R_1$  as shown in Fig. 27. The same value of impedance is not required in each shunt path, and the correct value is obtained by biasing the rectifiers to have a lower impedance than that required and adding a suitable value of series resistance.  $R_2$  and  $R_3$ , Fig. 27, are the series resistors in the receive and transmit shunt paths respectively. The transmitter shunt is connected to the receiver side of the balance circuit in order that the d.c. blocking capacitor is included in it, thereby saving an additional capacitor.

The complete regulator circuit is mounted on a small printed wiring board, one end of which forms a 5-point plug for inserting into a jack mounted on the telephone base. The other end of the board forms a dummy plug, the insertion of which completes an unregulated telephone circuit. The unit construction and methods of connecting the regulator to the circuit facilitate construction, production testing, fault finding, and easy replacement of a faulty regulator. The jack is mounted on the base between the sides of the gravity switch and is labelled A, B, C, D and E as shown in Fig. 23.

SHARED SERVICE TELEPHONESGeneral

Shared service working is a method of providing telephone service to two subscribers, each having a separate telephone number, by utilizing a common pair of wires over which signalling and speech currents are transmitted. One subscriber of a pair is known as the X subscriber and the other as the Y subscriber. Originally, shared service subscribers on automatic exchanges shared a common line, exchange equipment and meter, but later an additional facility of separate metering, i.e. the calls proper to each subscriber are recorded on individual meters, was introduced. There is no secrecy between two sharing subscribers.

Automatic Exchange Areas

In the common metering system the following facilities are provided.

- (a) Outgoing calls may be originated by either subscriber in the normal way, using an exchange calling equipment which is common to both subscribers.
- (b) All automatically registered calls originated by the two sharing subscribers are recorded on the meter associated with the X subscriber's number.
- (c) A separate number is allocated to each subscriber, and all incoming calls are completed on an automatic basis with selective ringing.

The method of originating a call is the same as for a normal direct exchange line, i.e. a loop is extended when either subscriber lifts his handset, and loop-disconnect pulses are transmitted during dialling. For incoming calls, however, the bell circuit is modified as the method of achieving selective ringing is the passage of ringing current over either the A or B-wire to earth. Thus, instead of connecting the bell and the capacitor directly between the A and B-wires, one side of the bell is connected to earth via the capacitor. The other side of the bell is connected either to the A-wire or to the B-wire as indicated in Fig. 32. The subscriber whose bell is connected in this way to the B-wire is designated the X subscriber, since ringing current is normally fed out over the B-wire. The Y subscriber's bell will be rung when ringing current is fed over the A-wire of the line.

To signal an incoming call, ringing current is fed over the appropriate line to earth return via the bell and the capacitor. When the subscriber lifts his handset, the A and B-wires are looped to complete an operate circuit for relay F in the exchange final selector and so trip the ringing in the normal way. The exchange equipment is designed to extend ringing current to the B-wire of a subscriber's line, consequently to obtain party line signalling conditions the Y subscribers connexion is reversed in the exchange as indicated in the elementary circuit connexion diagram Fig. 32.

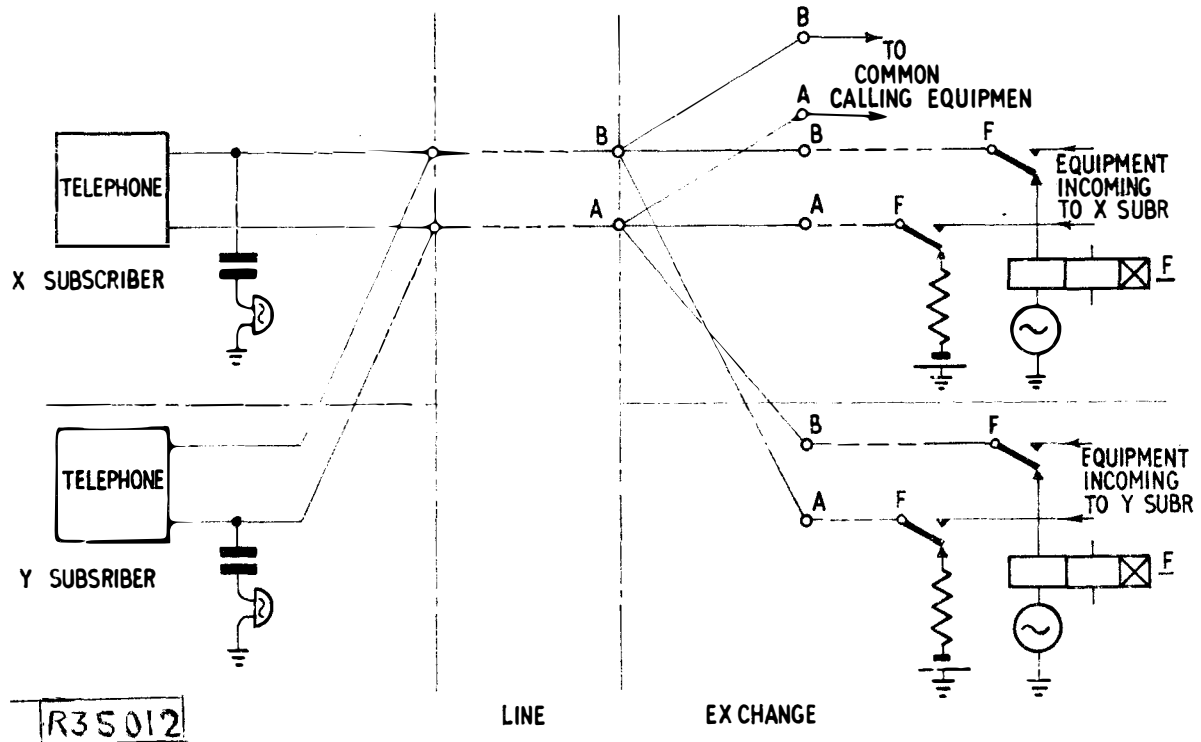

Fig. 32

The facilities offered by the separate metering system are as follows:-

- (a) Each telephone is fitted with a calling button which is depressed before the caller lifts the handset when originating a call. When dial tone is received the button is released and dialling can commence.
- (b) Each subscriber is allotted a separate exchange calling equipment, and meter.
- (c) A separate number is allocated to each subscriber, and all incoming calls are completed on an automatic basis with selective ringing.

The method of originating a call differs from normal practice and a simplified element diagram of the arrangement is shown in Fig. 33. In practice the circuit is so arranged that the X and Y subscriber cannot originate a call unless the exchange equipment is normal, but for simplicity this is not shown in the diagram. Consider an X subscriber, the depression of the button and lifting of the handset causes an earth to be extended via the telephone loop to the B-wire and via the metal rectifier to the A-wire. The connexion of the rectifier, however, is such that the A-wire will not be materially affected, and the earth on the B-wire causes relay L in the X subscriber's line equipment to operate. Similarly, when the Y

subscriber originates a call, earth is extended over the A-wire to operate relay L in the Y subscriber's line equipment. In both cases, on receipt of dial tone the subscriber releases the press button, and dials in the normal manner. The incoming call conditions are the same as those in the common metering system.

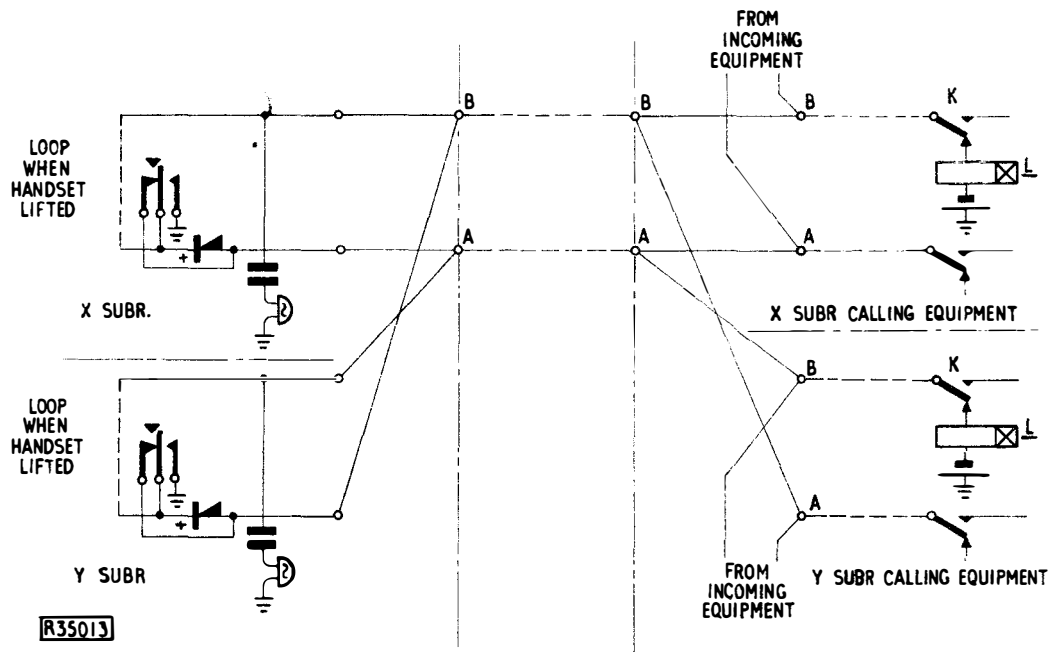

Fig. 33

### Manual Exchange Areas

The subscriber's telephone circuit arrangement for shared service working in a manual exchange area is similar to that shown in Fig. 32. At the exchange a common answering equipment is provided for the two sharing subscribers, consequently the same calling lamp glows when either subscriber originates a call. When answering the calling signal the operator ascertains both the calling and the called subscribers numbers, the call is then recorded on a ticket.

### Practical Circuits

The transmission circuit of a telephone suitable for shared service working is the same as that for a normal telephone, special consideration must be given to the bell circuit, however, when the telephone is used in automatic areas.



Consider the circuit elements shown in Fig. 34, which show the conditions which exists when the X subscriber is dialling. The two bell circuits effectively form a

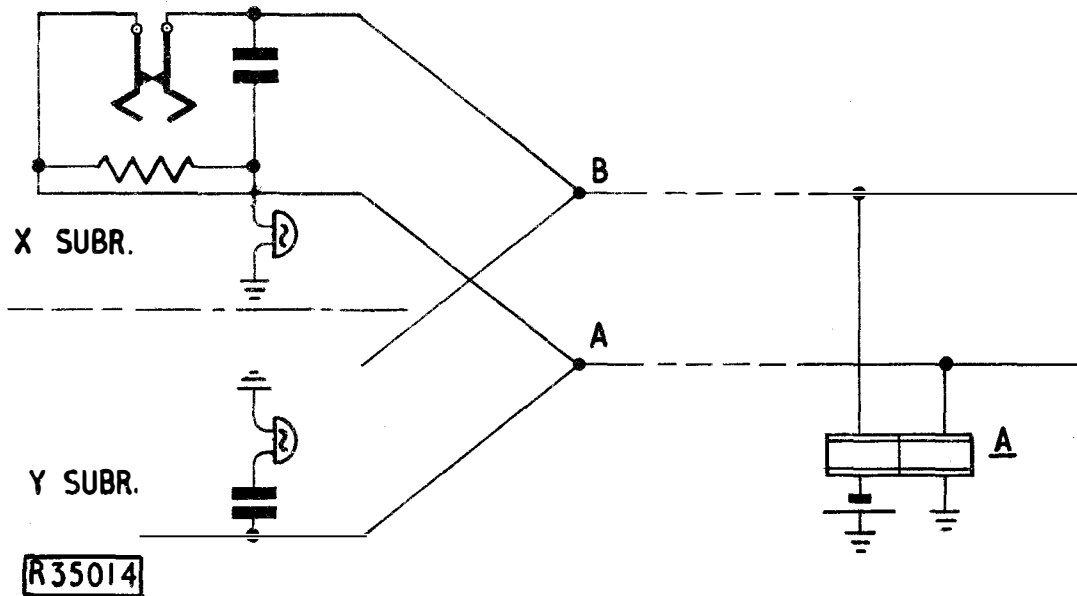

Fig. 34

series circuit between the A- and B-wires, and are, therefore, subject to the voltage surges caused by the loop disconnect pulses during dialling. Such a condition causes the bell to tinkle at both installation when either subscriber is dialling, and consequently is not acceptable. Originally both bell armatures were biased by means of a flat spring, the tension of which was just sufficient to prevent the operation of the armature to the voltage surges. The 'bias spring' method was not altogether satisfactory because of the difficulty experienced on certain lines of obtaining an adjustment which prevented operation to surges but allowed operation to the ringing signal.

A more suitable arrangement to suppress the bell tinkles is the use of a

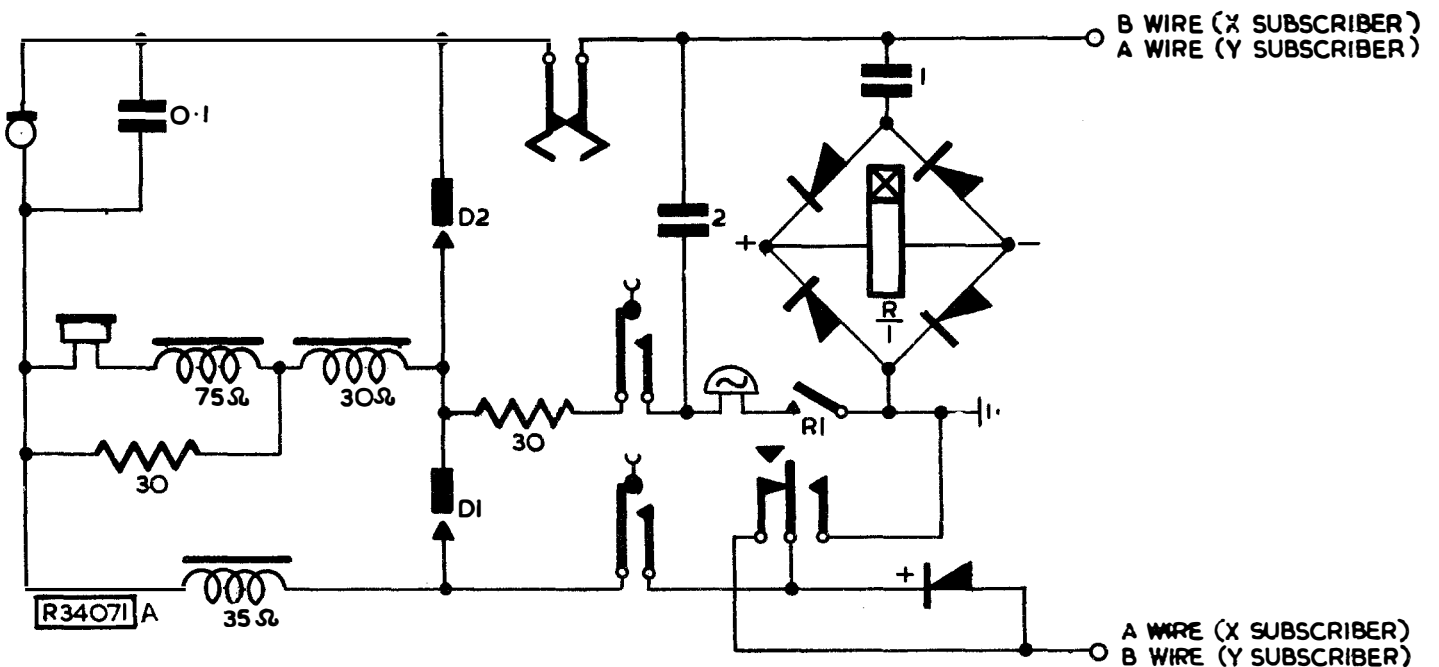
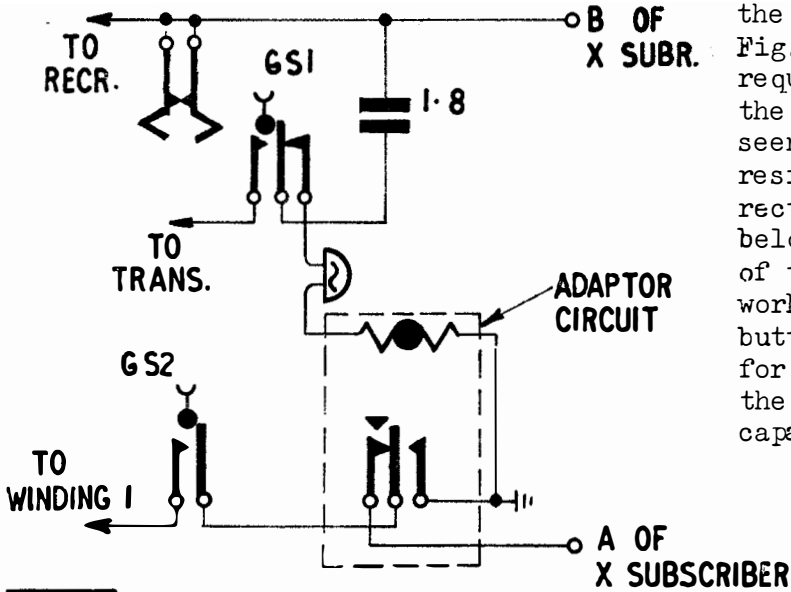

Fig. 35



The Telephone No. 706 is made suitable for use in shared service lines by the addition of a 'shared-service adaptor'. Fig. 37 shows the circuit arrangement of the adaptor and its position in the circuit of the telephone. A photograph of the call button and thermistor mounted on the gravity switch assembly is shown in Fig. 38 (appended), the 5-wire connexion required to associate the adaptor with the telephone circuit can be clearly seen in the figure. The carbon type resistors, resistance lamp and tubular rectifier pack situated immediately below the adaptor are the components of the regulator. On C.B. manual working there is no need for the call button and the telephone is arranged for shared service working by connecting the side of the bell remote from the capacitor directly to earth.



R35015 A

Fig. 37

PORTABLE TELEPHONE

The portable telephone although it is not a subscriber's instrument, is included in this pamphlet because it is used extensively for service purposes.

The telephone, complete with the handset, ringing generator, and dial is contained within a rectangular shaped case. The transmission circuit, Fig. 39,

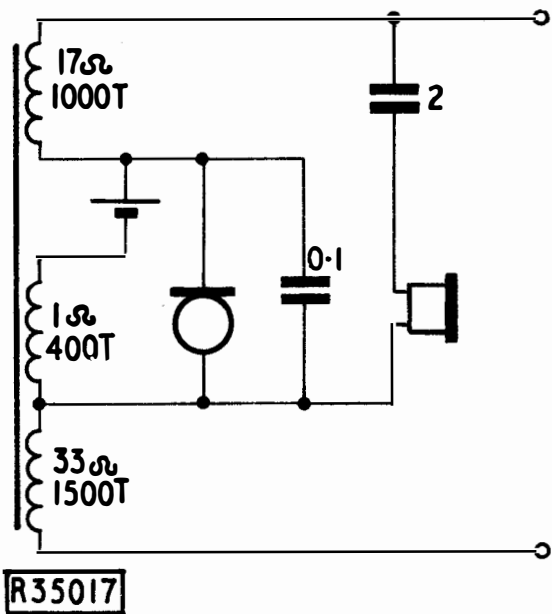

R35017

Fig. 39

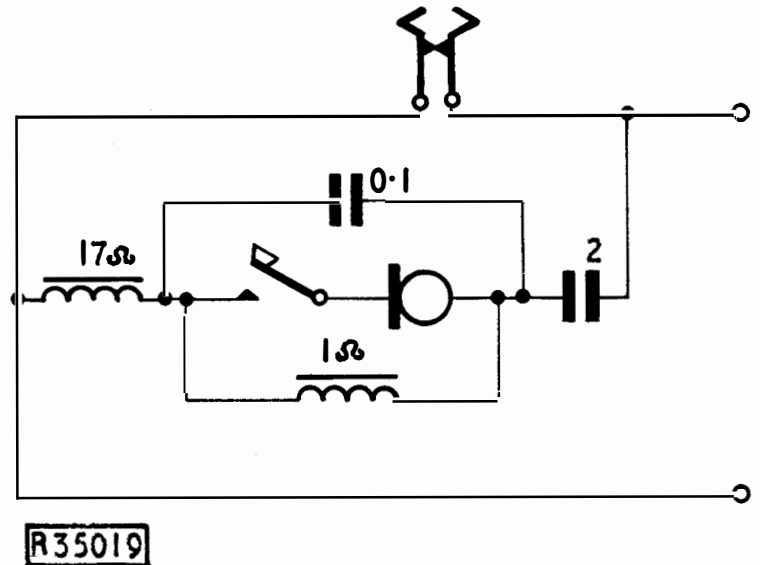

R35019

Fig. 41

although similar to that of the local battery telephone shown in Fig. 4, is arranged to supply direct current to line when the handset is off so that conversation can be carried on with a C.B. subscriber when the line is disconnected from the exchange battery. The complete circuit of the telephone, known as the Telephone No. 250, is shown in Fig. 40 (appended).

The transmitter circuit is under the control of both the gravity switch contacts and a switch built into the handset, thus the transmitter can be disconnected, i.e. 'cut off', without affecting the rest of the circuit.

The circuit condition during pulsing, i.e. when the dial off-normal springs are operated, is shown in Fig. 41. The spark quench circuit contains windings of the induction coil but this inductive component does not unduly distort the dial pulse shape and duration.

### CONCLUSIONS

The table type combined sets shown in Fig. 16 and 21 are the telephones normally fitted at subscribers' premises, other types of instrument are, however, available to meet special requirements.

A wall type A.S.T.I.C. telephone having a circuit similar to that shown in Fig. 15 is illustrated in Fig. 42; the same telephone with the cover removed is shown in Fig. 43 (appended). There is also a modern wall type telephone (Telephone No. 711) in the 700-Type series of telephones; the circuitry of which is similar to that of the Telephone No. 706 previously described. The wall telephones can, with slight modification, be used for shared service working.

Numerous other types of telephone are available for various industrial locations such as coal mines, the circuits of these telephones in the main, however, follow the principles outlined in this pamphlet.

END

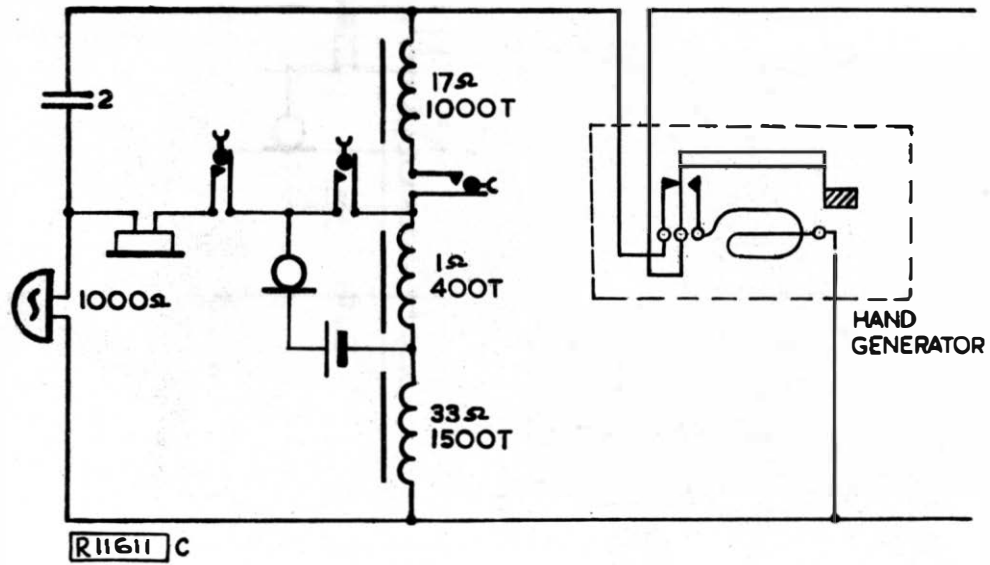

Fig. 5



R31449

Fig. 16

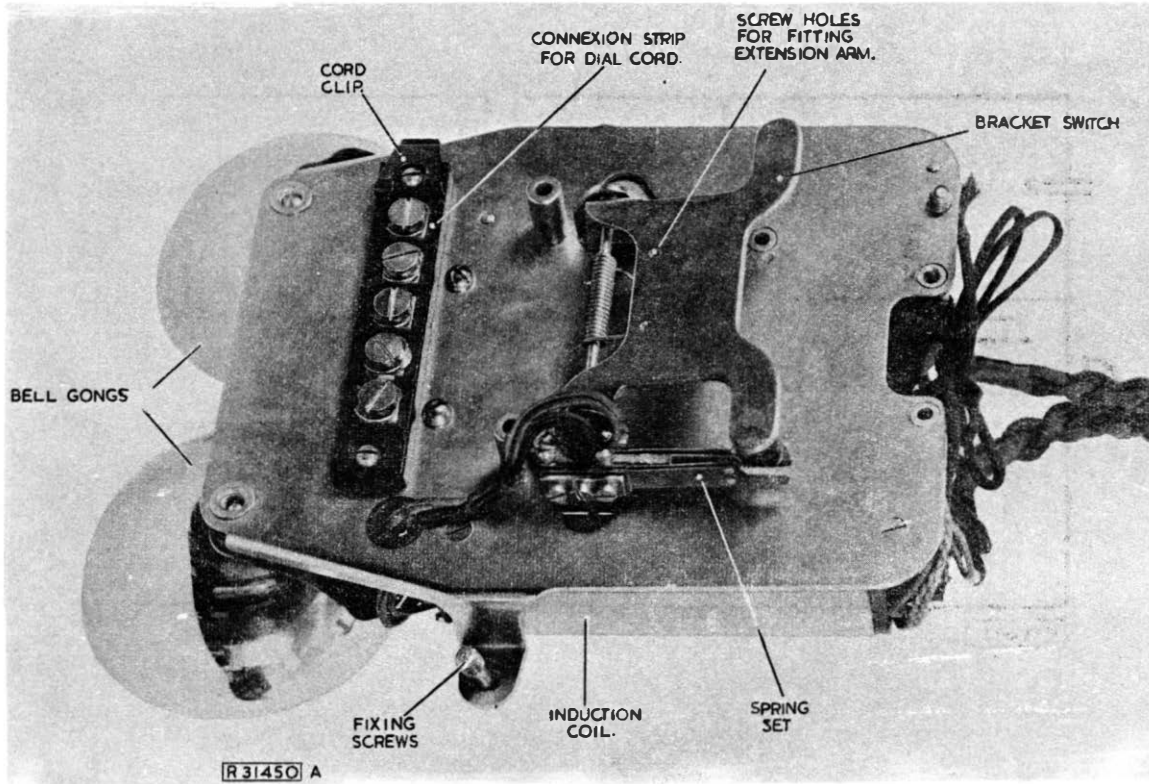

Fig. 17

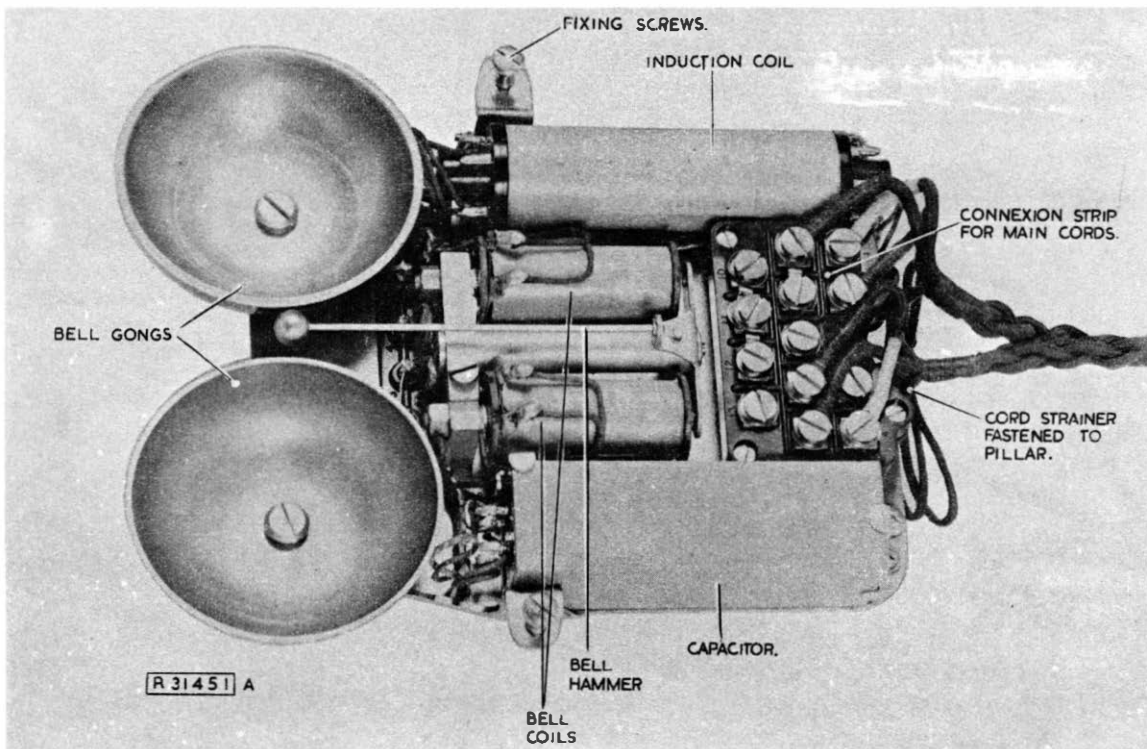

Fig. 18  
30.



Fig. 21

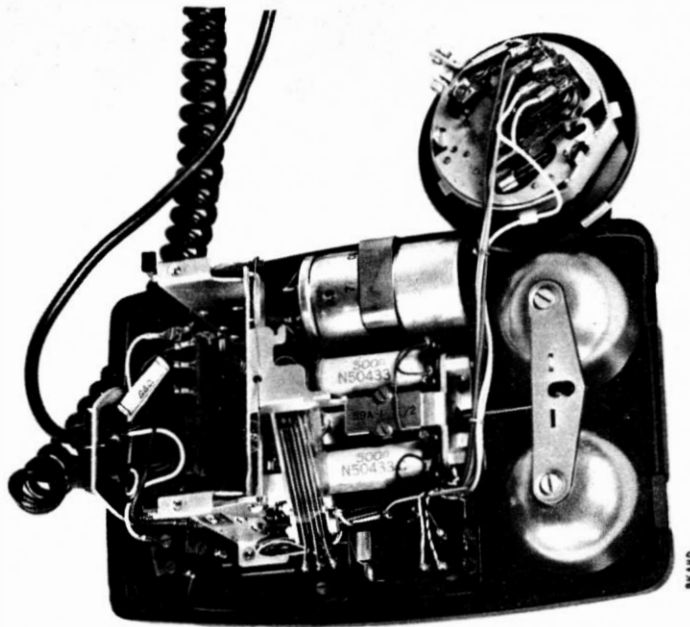
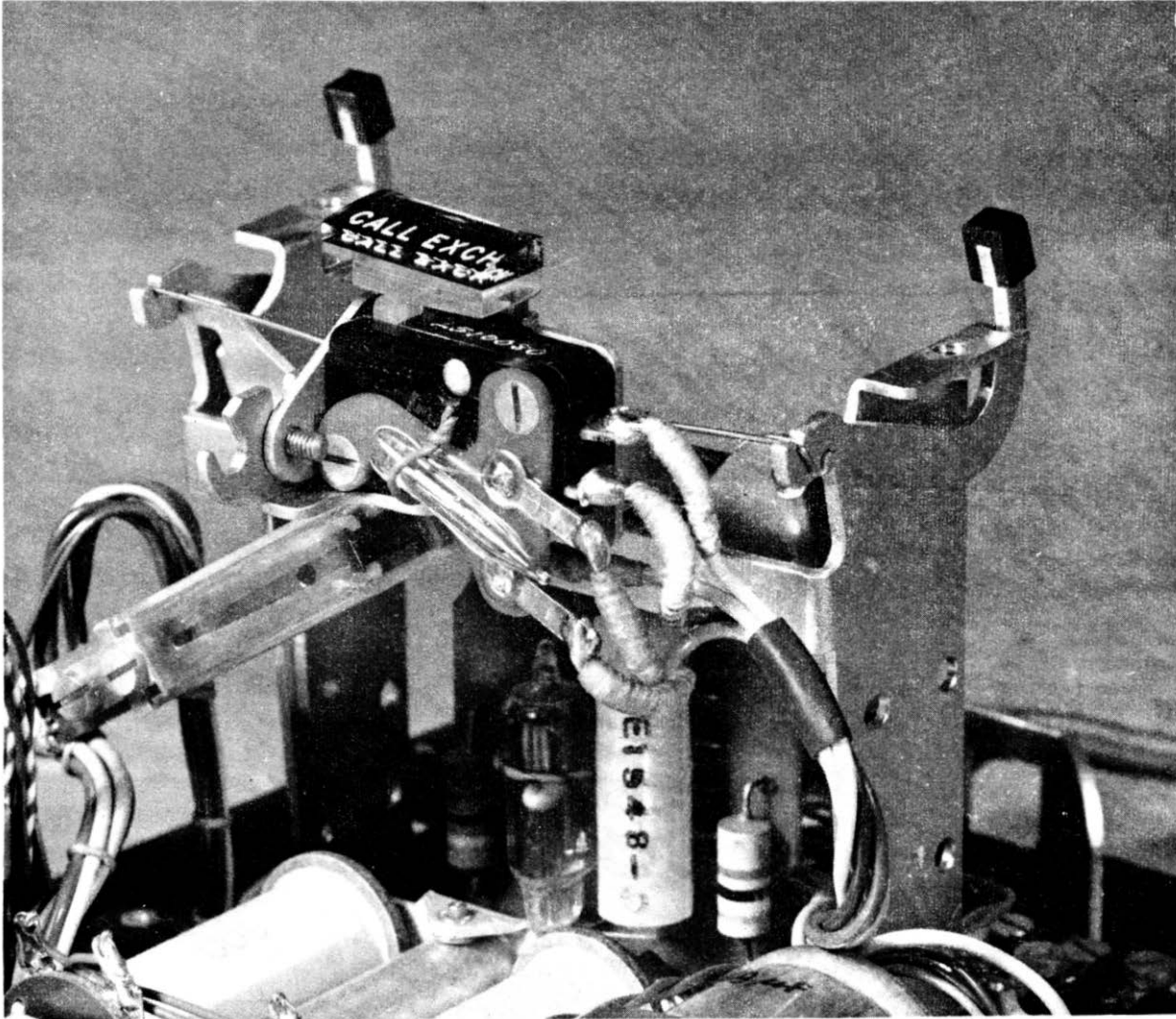

Fig. 23  
31.



R35016

Fig. 38



TELEPHONE No. 250.  
LINESMANS PORTABLE TELEPHONE FOR ALL SYSTEMS.

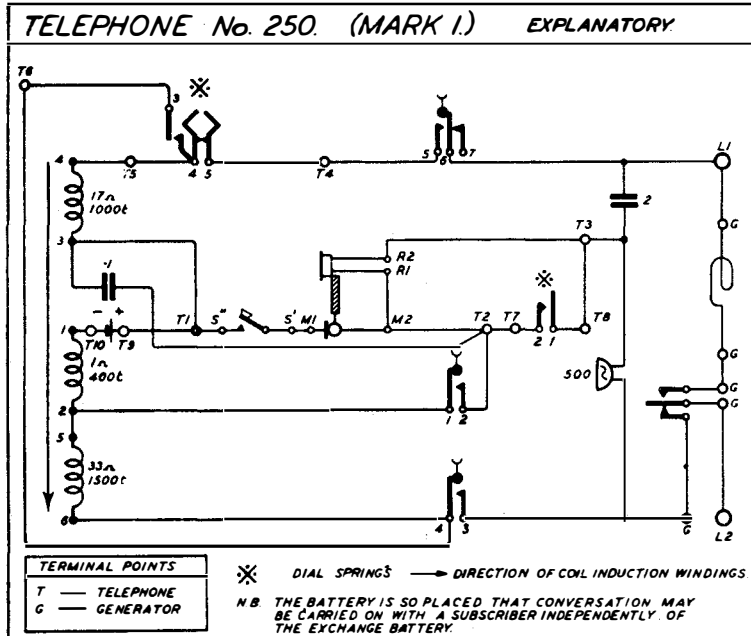
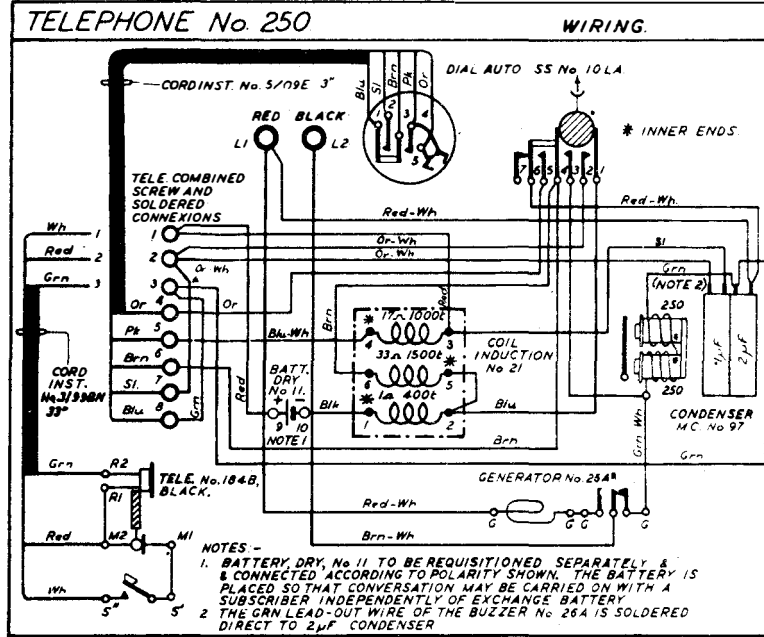
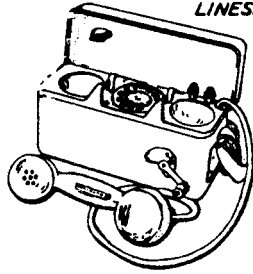

R35018

Fig. 40



Fig. 42

R35020

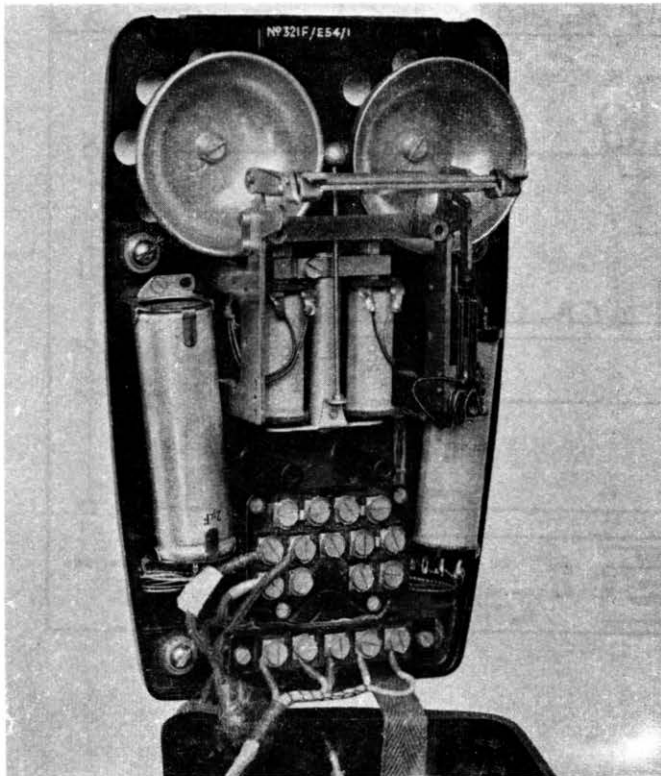

Fig. 43

R35021