

PROTECTIVE DEVICES USED IN TELEPHONE AND TELEGRAPH LINES

CONTENTS

	Page
Scheme of protection	1.
Line fuses and mountings	4.
Heat coils	9.
Protectors	12.
Protector units	14.
Gas discharge tubes	17.
Limitations of protection	17.

SCHEME OF PROTECTION

Telephone and telegraph lines are liable to interference from lightning discharges, contact with power conductors and induction from power lines. The methods used to reduce the liability of danger to telephone users and damage to apparatus from these sources are classified under the two general headings, "Guarding" and "Protection".

Guarding is the placing of an effective physical barrier between the line plant and the power plant.

Protection is the placing of voltage and current limiting devices at suitable points in the telephone or telegraph circuit. These devices and their application are described in this pamphlet.

The general scheme of protection and the function of each device is as follows:-

(a) To limit the voltage which can exist between the line and earth a spark-gap type voltage limiting device is used. This will operate at a predetermined voltage and earth the circuit while the voltage persists. This device is known as a 'protector'.

(b) To limit the current which can flow in the line or apparatus a fuse is connected between the external line wire and the internal apparatus. The function of this fuse is to disconnect the external wire should a current greater than a predetermined value flow in this wire and the internal apparatus, to earth.

(c) To limit the time of flow of a current which is smaller in magnitude than that necessary to operate the fuse, but large enough to damage the apparatus through overheating, a heat coil is used. This is a delayed action device which, when operated, earths the line wire.

The functions of the fuse and heat coil can be combined in one protective device; the delay-action fuse. This device rapidly disconnects the circuit when a current larger than a predetermined value flows through it or disconnects the circuit after a delay when the current is below this value but still sufficiently high to damage the apparatus if allowed to flow for a long time.

The design of the protective devices is such that they do not appreciably reduce the signalling and transmission efficiency or increase the fault liability of the circuit into which they are introduced.

In practice it has been found that the combination of fuse, protector and heat-coil or its equivalent is not necessary on every type of external circuit. The form of protection provided on the various types of external circuit is given in Table 1.

TABLE 1

Circuit	Protection provided
Exchange to exchange, wholly underground or with less than five spans of overhead wiring.	None.
Exchange to exchange with more than four spans of overhead wiring.	Full protection (fuses, heat coils and protectors) at each end of the circuit.
Subscribers to exchanges opened before 1960, with less than five spans of overhead wiring.	Fuses, heat coils and protectors at exchange, none at subscriber's premises.
Subscribers to exchanges opened before 1960, with more than four spans of overhead wiring.	Fuses, heat coils and protectors at exchange, protectors only at subscriber's premises.
Subscribers to exchanges opened after 1959, with less than five spans of overhead wiring.	Delay-action fuse at exchange, no protection at subscriber's premises.
Subscribers to exchanges opened after 1959, with more than four spans of overhead wiring.	Delay-action fuse at exchange, protectors at subscriber's premises and at the junction between the overhead wiring and the underground cable.

The same standard of protection is provided at any one exchange for all subscriber's lines that is, either fuses, heat coils and protectors or delay-action fuses. This is because of the impracticability of separating, at the exchange, those lines with overhead wiring from those lines without. For the purpose of protection requirements metallic sheathed aerial cable is considered as underground cable, and non-metallic sheathed aerial cable as open-wire.

In addition to the points already mentioned protection is, in certain circumstances, provided at the point where cables are connected to open wires and at points in open wire routes.

The circuit arrangement of the combination of protector, heat coil and fuse provided in each wire of a subscriber's line at a pre 1960 exchange is shown in Fig. 1.

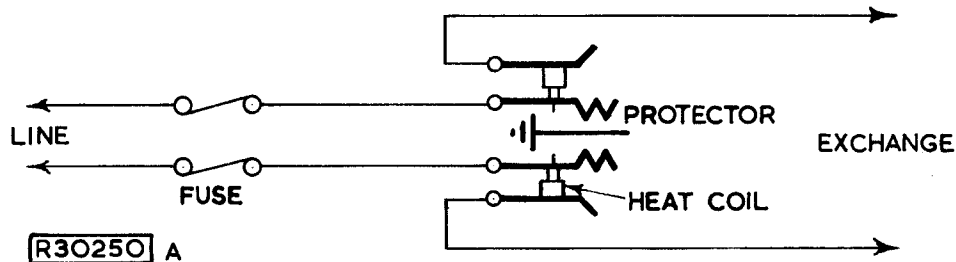

Fig. 1

The function of pre 1960 exchange circuit for each of three possible types of voltage interference is as follows:-

(a) Lightning discharge (not a direct stroke)

A nearby lightning stroke, which is an electrical discharge of extremely short duration, creates in the line a high voltage having a complex waveform which contains high frequency components. The impedance of the path to earth offered by the exchange apparatus to the high voltage is much greater than that of the protector air gap. Consequently the interfering voltage is conducted through the fuse and the arc created across the protector air gap, to earth.

(b) Sustained voltages above 600 volts.

A voltage greater than 600 volts is sufficient to create an arc across the protector air gap. The sustained voltage maintains the arc, and the heavy current which flows in the line, fuse and protector operates the fuse to disconnect the line from the exchange apparatus.

(c) Sustained voltage below 600 volts.

A voltage below 600 volts is insufficient to create an arc across the protector air gap. The current caused by the voltage passes through the heat coil and exchange apparatus to earth, and if this current is in excess of the rating of the heat coil, the heat coil operates and earths the line. The increased current operates the fuse and the line is disconnected.

This scheme of protection has limitations, and these are considered later in this pamphlet.

In locations such as the Highlands of Scotland, high voltage power lines and open wire telecommunication circuits necessarily run parallel to each other for considerable distances. Consequently the risk of high voltages being induced in

the telecommunication circuits if earth faults occur on the power circuits, is very high. Protection on such circuits is effected by the introduction of gas discharge tubes at each end and at intermediate points along the route. A gas discharge tube is a device for earthing the line when the voltage between the line and earth reaches a certain value.

The lower voltage limit at which the tubes are designed to operate is set by the voltages employed in the telecommunication circuits. In practice it is specified that the tube does not operate at voltages less than 150V r.m.s. at 50 c/s and operates at a voltage not greater than 250V r.m.s. at 50 c/s.

Power lines are fed from both ends, and an earth fault at a point in the line causes heavy currents to flow in opposite directions towards the fault. The voltages induced in the telecommunication circuit on each side of the point opposite the fault will, therefore, act in opposition to each other. Gas discharge tubes situated at each end of the line will operate only when the difference between the two induced voltages exceeds the operate voltage of the tubes. If the induced voltages are equal the tubes will not operate, but a potential to earth, equal in value to the induced potential, will exist at a point on the circuit opposite the earth fault. When such a condition exists the appropriate intermediate tube or tubes operate to protect the circuit.

A detailed description of the design of gas discharge tube installations for protective purposes in telecommunication circuits is beyond the scope of this pamphlet.

LINE FUSES AND MOUNTINGS

FUSES

The heat developed by an electric current raises the temperature of the conductor and of the surrounding materials at a rate depending on the mass and the specific heat of the materials heated. If the development of heat continues indefinitely, the temperature may rise so high as to damage the conductor and the insulation and even set fire to surrounding objects. Fuses are introduced into circuits to prevent this type of damage.

The fuse is defined as a device for opening a circuit by means of a conductor designed to melt when an excessive current flows. In practice the fuse comprises all the parts that form the complete device. The properties desirable in a fuse are that it should 'blow' quickly without scattering molten metal and that any arc which may be set up when the conductor melts cannot be maintained.

The "rating current" of a fuse is the maximum current it will carry indefinitely without blowing. This value is approximately one-half of the "fusing current", i.e. the minimum current which will cause the fuse to blow almost instantaneously. A fuse does not blow quite instantaneously, there being a time lag dependent upon the value of the current applied, therefore the current actually flowing in the conductor at the instant a fuse is blown may be many times the nominal fusing current.

The working currents in telegraph and telephone line circuits are small, and a fuse having a fusing current of 1 amp would generally provide sufficient margin above the working currents. In circuits exposed to voltage surges caused by lightning or power wires, such fuses would blow too frequently and so cause severe interruptions of service. In practice subscriber's line circuit fuses have a fusing current of 3 amp.

TYPES OF LINE FUSES

Porcelain tube. This type of fuse is fitted in the older type fuse mountings at some telephone exchanges; it was also fitted in the older type protector units at subscribers' premises. The fuse wire is of phosphor bronze having a fusing current of 3 amp, and is inserted in a small-bore porcelain tube fitted with metal end caps as shown in Fig. 2.

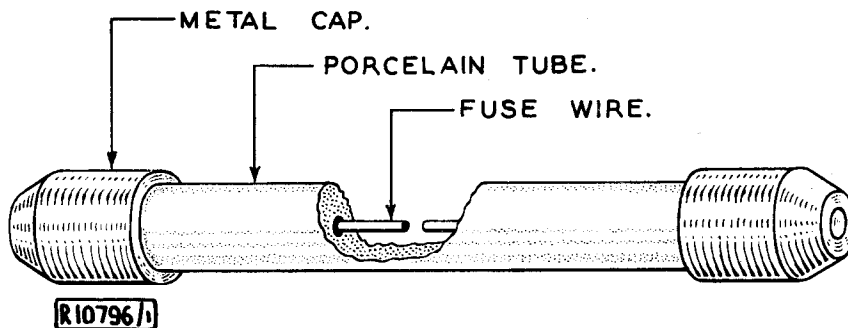

Fig. 2

Hexagonal ceramic tube. This fuse was developed to fit a type of protector unit fitted at subscribers premises. The fuse is fitted with one-piece side-contact lugs and the ceramic tube is made hexagonal to ensure alignment of the contact tongues as shown in Fig. 3. To reduce the number of interruptions due to lightning the fuse blows after 30 seconds when carrying a current of 5 amp. As previously mentioned the practice of fitting fuses at subscribers' premises has now ceased.

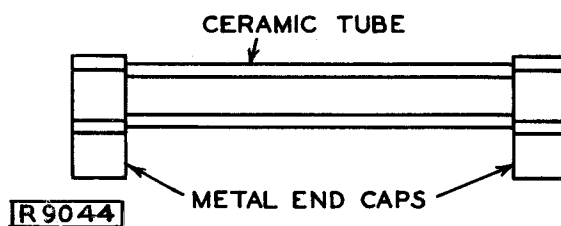

Fig. 3

Asbestos tube. The fuse wire is enclosed in an asbestos tube held between flat body-pieces of an insulating material known as press board. The wire is soldered to copper end-caps which grip the asbestos tube and press board as shown in Fig. 4.

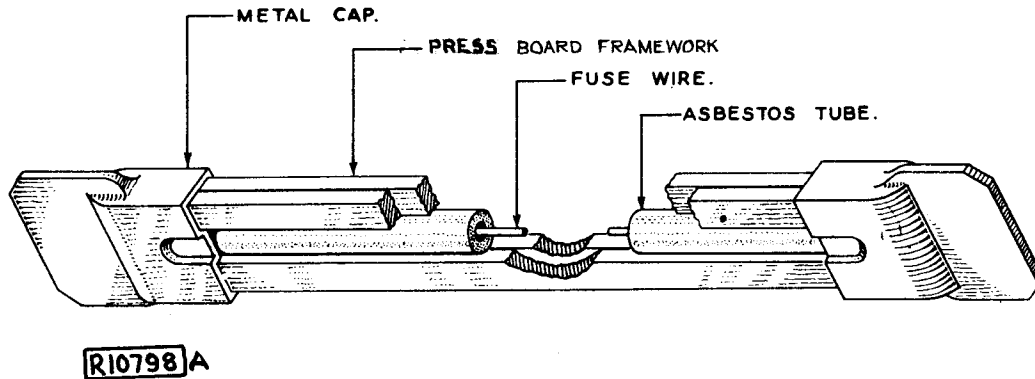
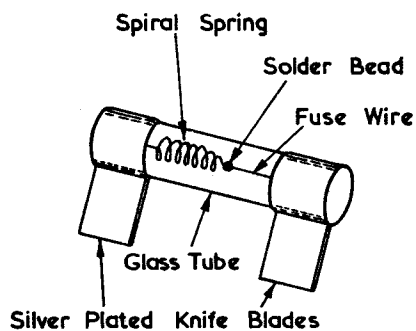

Fig. 4

This fuse is rated to carry 1.5 amp continuously without deterioration and to blow within 30 sec of the current reaching 3.0 amp.

Delay-action fuse. The delay-action fuse consists of a length of fuse wire, a bead of solder and a helical spring, contained within a glass tube with metal end connexions as shown in Fig. 5. Most of the electrical resistance of the fuse is in the fuse wire which, with sufficient current flowing through it, develops enough heat to melt the solder. On the melting of the solder, the spring retracts and the fuse is open circuited. When large currents flow through the fuse the fuse wire itself melts to disconnect the circuit.



This fuse has a rated current of 200 mA and blows within 5-300 seconds when carrying 350 mA.

Fig. 5

LINE FUSE MOUNTINGS

In an exchange the line fuse mounting is used as the terminating point for the external cable. The mountings are made in units each accommodating 40 fuses and providing for the termination of 20 circuits. The mounting for the delay action fuse accommodates 80 delay action fuses and provides terminations for 40 circuits.

A type of unit, a large number of which are still in service, is shown in Fig. 6. This unit has twenty fuse mountings on each side of a centrally situated zinc-plated mild-steel plate. Clamped to this plate, but insulated from it and from each other, are the sets of nickel-silver springs between which the fuses are held. Opposite fuses on the left and right of the plate constitute a pair and are connected to the A and B conductors respectively of one circuit. The connexions for each pair of fuses are brought out at the rear on tags. To facilitate wiring, the tags for the corresponding ends of the two fuses of a pair are arranged on the same side of the central plate.

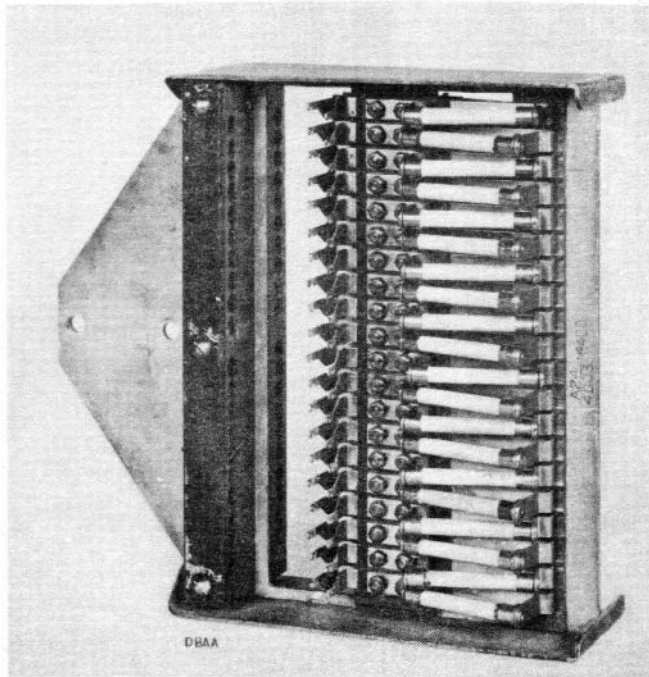

Fig. 6

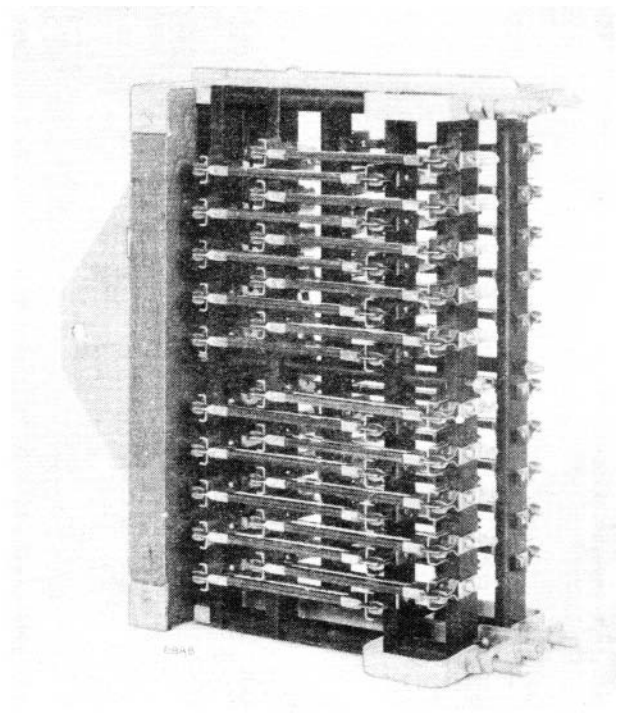
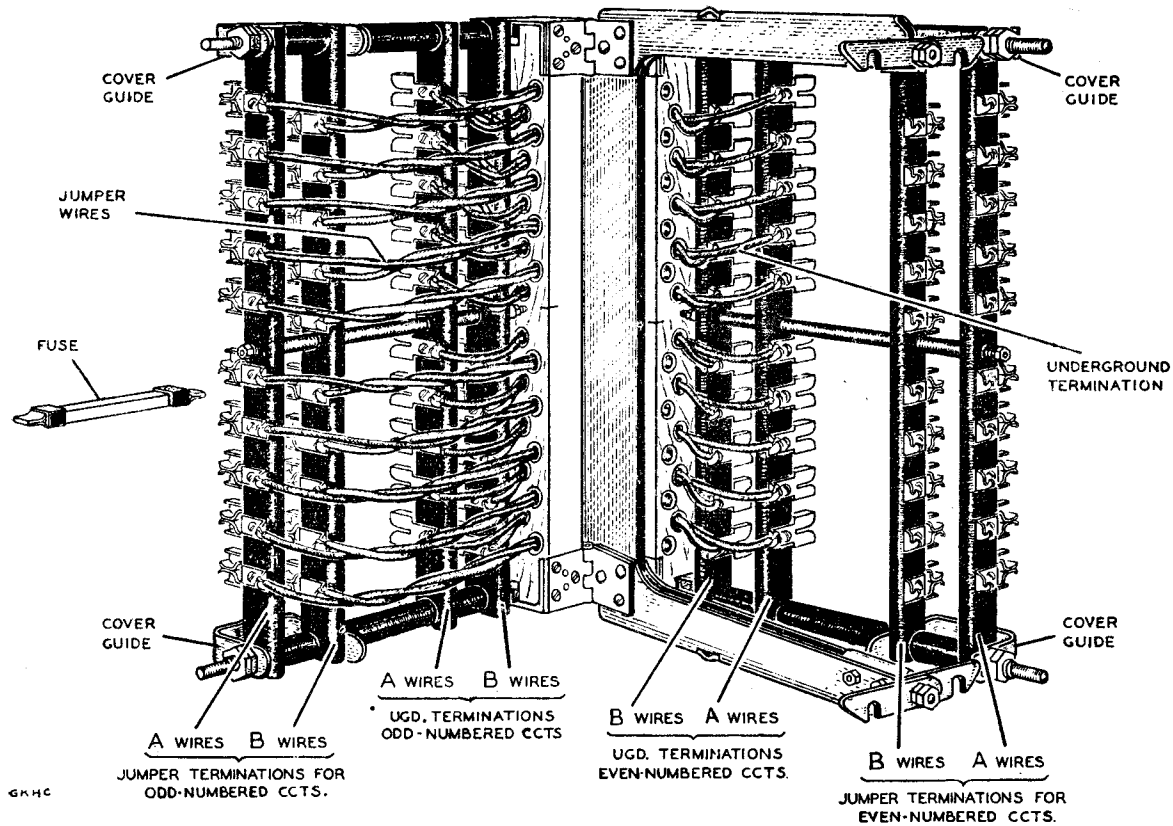

Fig. 7

Alternate fuses are mounted at different angles, or, to employ the usual term, are "staggered". This is done to give ease of access in removing and replacing fuses, and to lessen the risk of contacts between the metal portions of adjacent fuses, without sacrificing compactness of design. In order to prevent troubles arising from loose contacts between the fuses and the springs, stringent precautions are necessary in manufacture, to ensure that the fuses are of uniform length and the springs of permanent resilience.

The fuse mounting for the asbestos tube fuse is shown in Fig. 7. This mounting was developed for use on long distance circuits where a higher standard of insulation resistance has to be maintained. Subsequently it was introduced as the standard line fuse mounting for both subscribers and long distance circuits.

Clips to accommodate the knife-edge of fuse shown in Fig. 4 are mounted on strips of insulating material which are fixed in a skeleton or gate form of framework. This framework is in two halves which are hinged separately and can be opened outwards to facilitate wiring operations. The soldering tags are short projections from the base of the fuse mounting clips. The arrangements for hinging the two frameworks to a central plate and the allocation of fuses to circuits is shown clearly in Fig. 8. In certain circumstances the mounting is provided with a dust-proof cover.



R34414

Fig. 8

The fuses in both types of line fuse mountings can be removed for testing purposes and replaced without the use of special tools.

The mounting for the delay-action fuse is shown in Figs. 9 and 10. Fig. 9 shows the left-hand side on which the fuses are mounted. Two fuses are shown fitted by the arrow C. Dummy fuses with the same physical size as the delay action fuse are used in power leads and ringing leads and are shown at A. The fuse covers B are used on high grade circuits and clip over the fuses or dummy fuses. The covers are made from red polystyrene and in addition to providing physical protection also act as markers to guard against inadvertent circuit interruption.

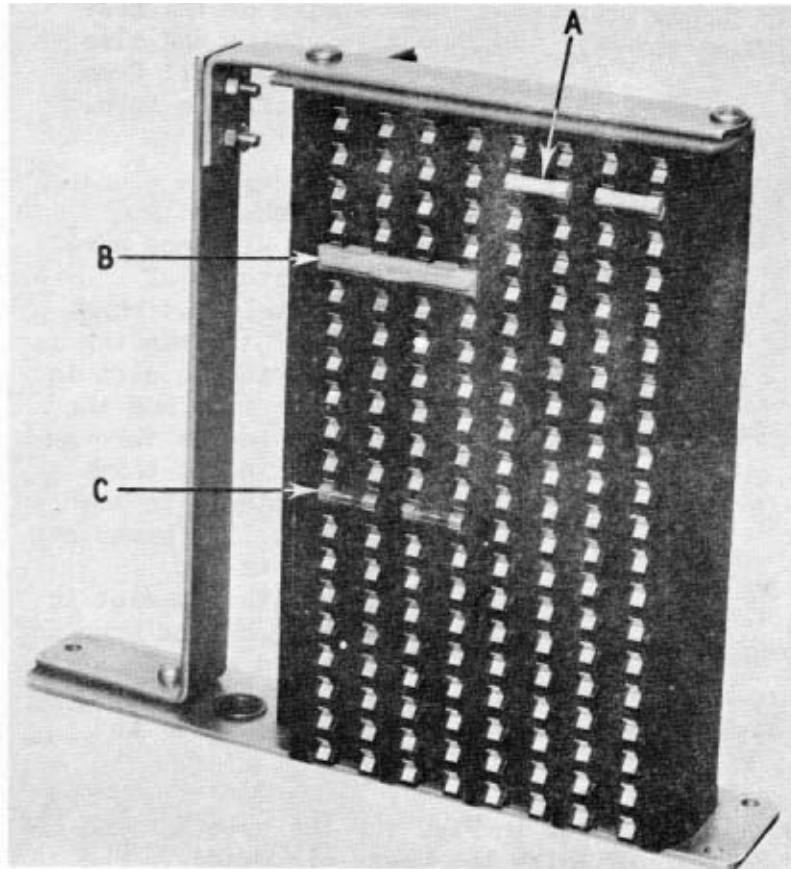

R35903

Fig. 9

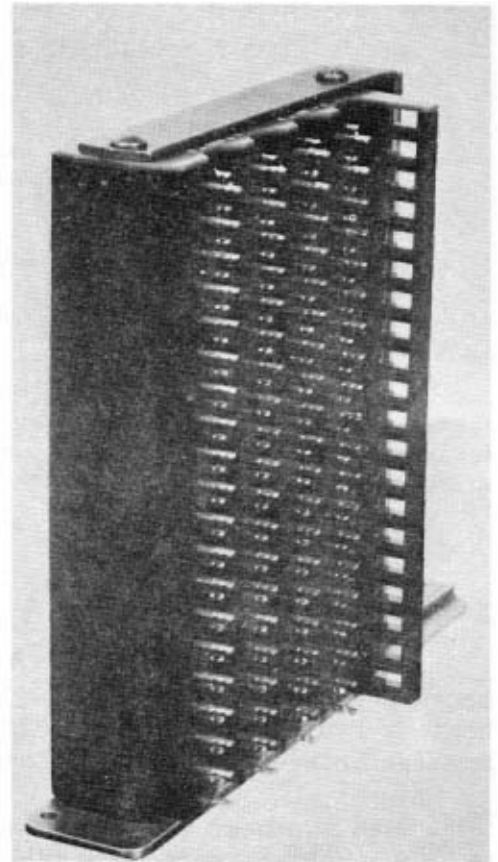

Fig. 10

R35904

The right-hand side of the mounting showing the soldering tags is shown in Fig. 10. The mounting is built up from 20 individual 2-circuit assemblies, which are interlocked by moulded dowels and clamped by long bolts. Any individual assembly can be removed after slackening the nuts on the two bolts.

HEAT COILS

The heat coil is a device designed to protect apparatus against damage from persistent currents which are not strong enough to blow the fuses but which would eventually damage the apparatus by overheating. The action of the heat coil depends on the heating effect of an electric current.

Two types of heat coil are in general use: the earthing heat coil, which, as its name indicates, connects the line to earth when it operates, and the break heat coil, which disconnects the line when it operates. The earthing heat coil is fitted when, necessary, in the line circuits at telephone exchanges, the break type was fitted at subscribers' premises but is now used only in certain types of circuits associated with the apparatus in telephone exchanges.

THE EARTHING HEAT COIL. This type of heat coil is shown in Fig. 11. The body of the heat coil is an ebonite split thimble, in the centre of which a brass pin is rigidly fixed. A copper tube is soldered to the pin with a low melting point solder which is composed of lead 27.6%, tin 10.3%, cadmium 34.5% and bismuth 27.6%. This particular alloy has been found to reduce the number of heat coil failures due to metal fatigue, i.e. operation of the heat coil with no current flowing. The

lower belled end of the copper tube provides a knife-edged contact with one spring of the heat coil mounting and also prevents the coil from slipping off the tube.

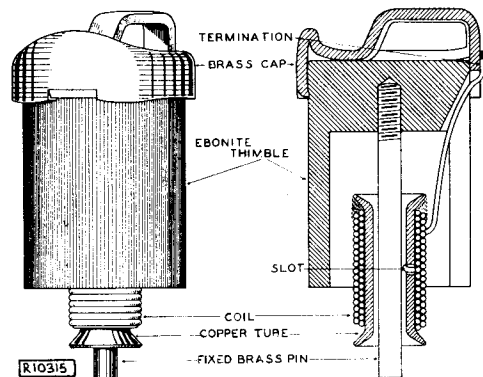

Fig. 11

The coil is wound with a double silk covered resistance wire to a resistance of approximately 5.1 ohms. One end of the winding is connected to the slot in the copper tube and the other end passes through the split in the thimble and is soldered to the brass cap. The brass cap is shaped to fit rigidly within a slot in the spring of the mounting to maintain a good

contact between spring and coil. This arrangement overcomes the intermittent contact faults experienced with the earlier type of heat coil which is free to revolve between the mounting spring.

When the heat coil is in the mounting as shown in Fig. 12, the external end of the copper tube rests on a fixed spring through which the brass pin passes. The pin engages a travelling spring which is fixed to, and in electrical contact with the fixed spring. The ebonite thimble is pressed towards the fixed spring by the tension of the outer spring against the brass cap. With the conditions shown in Fig. 12 a circuit from the fixed spring, which is connected through the fuse to the external line, to the outer spring which is connected to the internal equipment is completed through the coil.

When a sufficiently heavy current of prolonged duration flows through the coil the heat generated melts the solder between the copper tube and the pin. The ebonite thimble then moves forward under the tension of the outer spring, carrying with it the brass pin which slides through the copper tube. The end of the brass pin pushes the travelling spring forward into contact with the earthed centre plate of the mounting, thereby earthing the line.

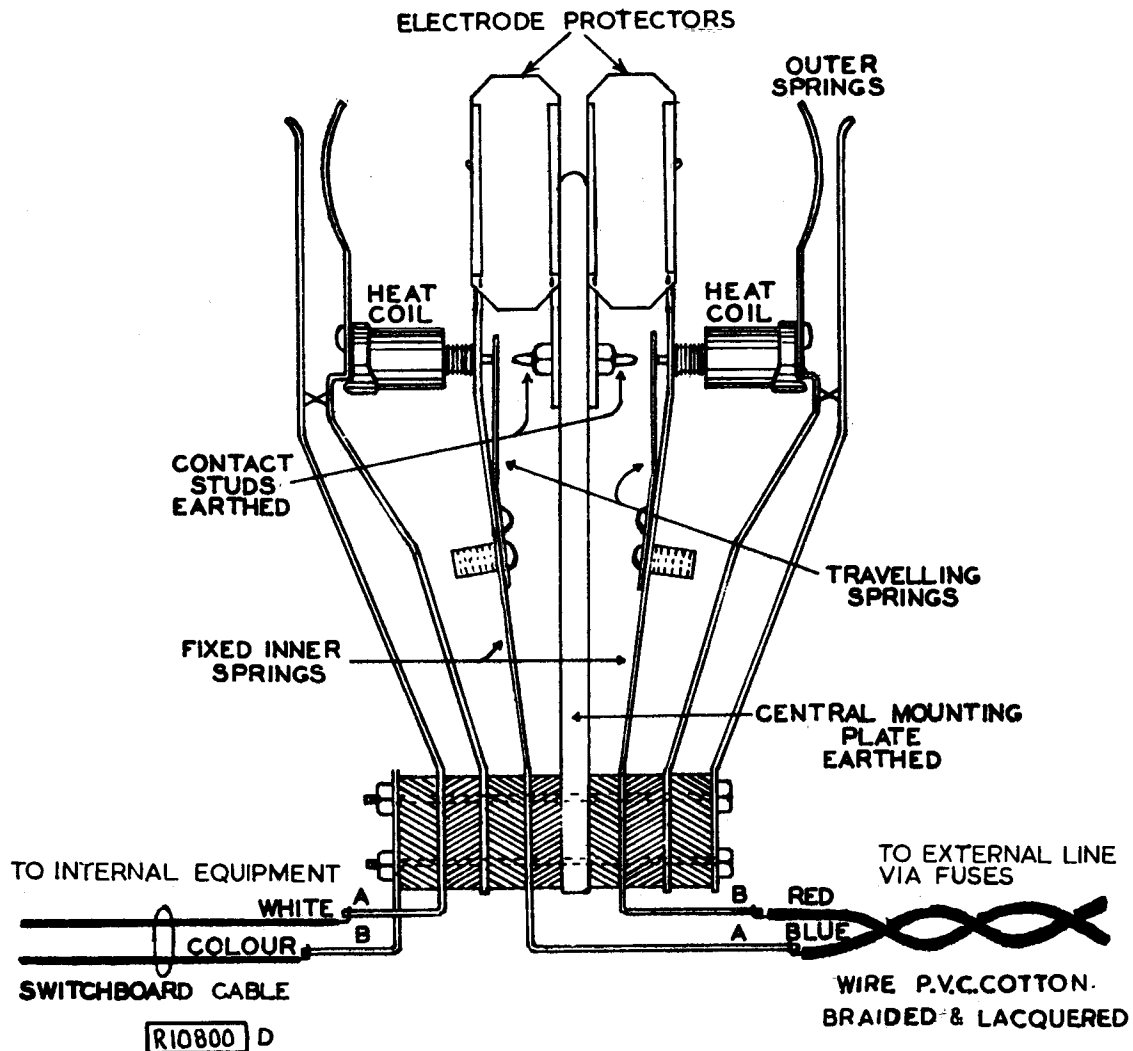

Fig. 12

This type of heat coil is designed to carry a current of 350 mA for 3 hours without operating, but to operate within 210 seconds when carrying a current of 500 mA and under a pressure of $2\frac{1}{2}$ lb-weight at room temperature.

THE BREAK TYPE HEAT COIL This type of heat coil is shown in Fig. 13. The coil is wound over a central brass stem fixed inside a brass thimble. The stem is insulated from the thimble by means of ebonite washers fitted at either end. Immediately below the brass thimble is a brass collar fitted with a tapped and tapered ebonite bush. The brass stem passes through the lower end of the brass thimble and is screwed into the ebonite bush, thereby clamping the brass collar and brass thimble tightly together.

The inner end of the winding is electrically connected to the central brass stem and the outer end is brought out through the brass thimble, the end bared and laid in a groove between the thimble and the brass collar. The thimble, collar and wire are then all soldered together. The upper end of the central brass stem, as shown in the figure, is drilled to receive a brass pin. This pin is of such a

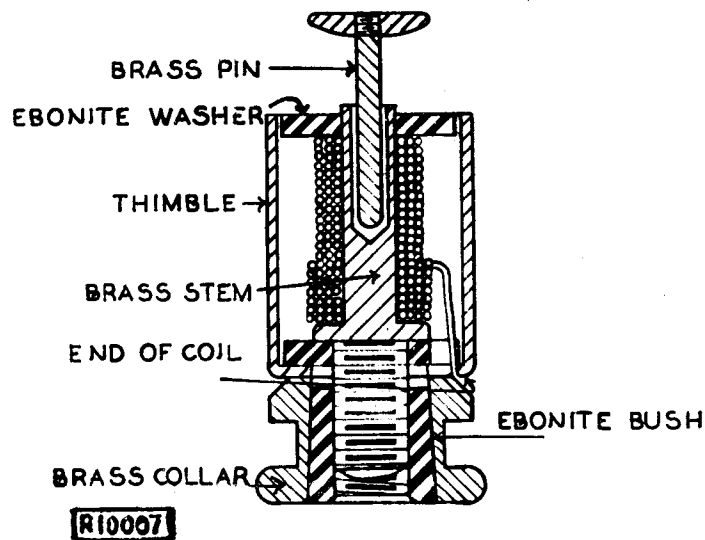

Fig. 13

diameter as to slide freely in and out of the hole in the stem, but is soldered to the stem by means of a special solder with a low melting point.

When mounted in the heat coil fitting the heat coil is held in tension between a fixed and a moving spring which engage respectively with the slot in the brass collar and the knob on the end of the brass pin. The circuit is completed from one spring to the other via the windings of the coil. When a sufficiently heavy current passes through the windings, the heat generated melts the solder which is holding the brass pin in the hole in the central brass stem, and the

tension on the moving spring pulls out the pin, thus disconnecting the circuit.

As already mentioned, this type of heat coil is no longer used in the protection of telephone lines. The type used in circuits associated with exchange apparatus has a coil resistance of the order of 0.6 ohms and carries 0.3 amp for 3 hours without operating, but operates within the limits 15 to 60 seconds when a current of 1.5 amp flows.

PROTECTORS

The protector is a device which offers a low resistance path to earth when the potential difference between the line and earth reaches a predetermined value. The potential difference is usually caused by lightning discharges, and the effective resistance of the path to earth through the protector is then very much smaller than that through the telephone or telegraph apparatus. Consequently the protector guards the apparatus against the high potentials.

The desirable properties of protectors are as follows:-

- (a) They should earth the line quickly when its potential with respect to earth reaches a predetermined value.
- (b) They should earth both lines of a circuit simultaneously, so as to reduce the risk of acoustic shock caused by heavy currents passing through the telephone receiver.
- (c) They should carry heavy discharge without undue heating.

- (d) They should have high insulation resistance up to the time of breakdown.
- (e) They should be self-restoring.
- (f) They should be capable of easy removal, examination and replacement.

TYPES OF PROTECTOR

Carbon protectors. The original lightning protector used on line circuit consisted of two grooved rectangular carbon blocks, one of the blocks having a fusible metal plug in its face. The two blocks were held under pressure with their faces together, contact between the two faces being prevented by a thin sheet of mica.

The effect of a lightning discharge melted the fusible plug which then flowed through a hole in the mica sheet, and short-circuited the two carbon blocks to connect the line to earth. This type of protector was not self restoring and gave rise to low insulation faults because of carbon dust collecting between the blocks.

A later type of carbon protector which, although obsolescent, is still in use, overcomes the low insulation difficulties and is, to a limited extent, self restoring. Each carbon block of this type of protector has a flat inner surface with bevelled edges as shown in Fig. 14.

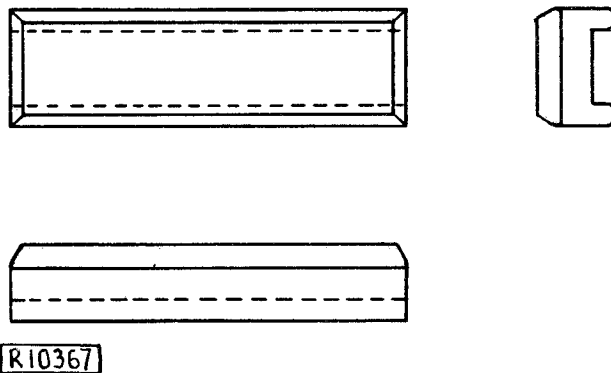

The discharge surface and the bevels are coated first with a thin film of anti-dust varnish, having a collodian base and containing fusible gum, non-drying oil and sufficient coloured pigment to assist application and identification; this is covered by a film of insulating varnish, with a clear cellulose acetate base, approximately 1.5 mils thick. This carbon is used on both the line and earth electrodes.

The dimensions of the blocks are 1.25 in x 0.37 in x 0.2 in with a slot in the outer surface, to fit the width of the guides on the spring mounting and the earth bar.

Fig. 14

The effect of a high voltage is to produce a small puncture in the insulating varnish, where the arc occurs. The heat produced melts the varnish round the puncture, causing it to run, and reinsulate the punctured area.

Electrode protectors. This type of protector is interchangeable with the carbon type protectors and is the standard protector used in telephone exchanges on external lines. The construction of the protector is shown clearly in Fig. 15. The two channel-section brass electrodes are separated by the perforated insulating

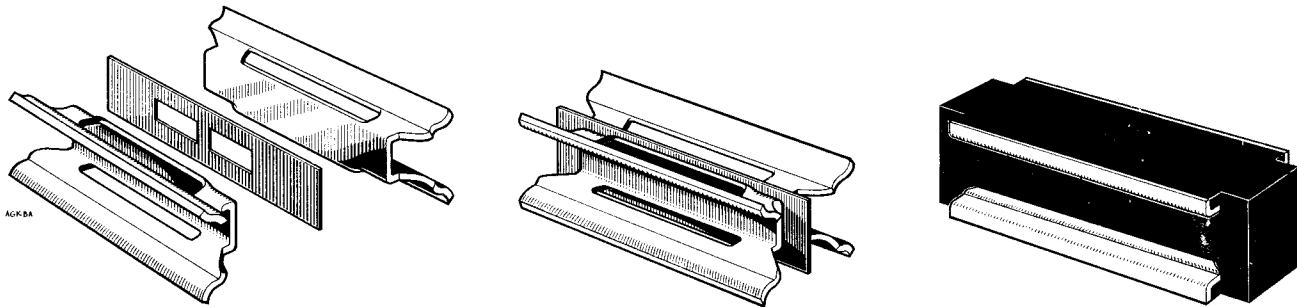

R34378

Fig. 15

film and the whole is enclosed in an injection moulding having a high insulation-resistance and low inflammability. The flanges of the electrodes project from the moulding and make contact with the springs on the protector mounting, Figs. 16 and 17.

These protectors will withstand repeated discharges of larger magnitude, without detriment and with more consistent performance, than carbon protectors. They are furthermore superior in damp or dusty situations because the air gap is enclosed. The electrode protector usually used in subscribers' lines has a range of breakdown voltage of 750 ± 150 volts, but in certain circumstances a similar type of protector having a range of breakdown voltage of 1400 ± 300 volts can be used.

PROTECTOR UNITS

HEAT COIL AND PROTECTOR MOUNTINGS. The heat coils and protectors are situated in a combined mounting fitted on the main distribution frame in the exchange. The plan of this fitting is shown in Fig. 12 which illustrates clearly the manner in which the various springs are assembled on either side of the central mounting plate.

The mountings are made up in units 11 in. long, each mounting accommodating heat coils and protectors for 20 circuits as shown in Fig. 16. Opposite heat coils and protectors on either side of the mounting plate are arranged to serve the two wires of one circuit. The method of arranging the connexion tags as shown in Fig. 12 facilitates wiring arrangements.

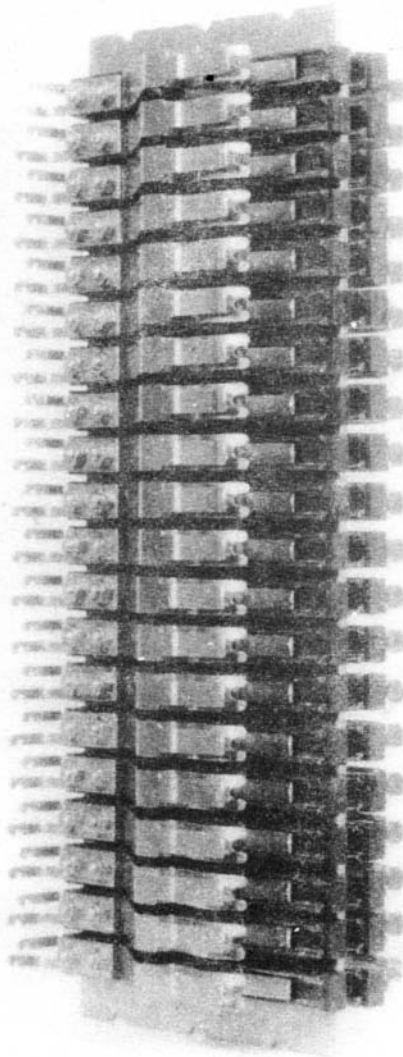

R34375

Fig. 16

PROTECTOR AND FUSE MOUNTING. The type of mounting which was fitted at subscribers' premises on lines other than those which were wholly underground is shown in Fig. 17. The mounting is a two-piece plastic moulding consisting of the base and cover. The dimensions of the mounting are 4 in. x $1\frac{1}{2}$ in. x $1\frac{3}{4}$ in. high. Originally the base accommodated two hexagonal ceramic fuses and two protectors electrode. With the introduction of the scheme of protection given in Table 1, dummy fuses have replaced the hexagonal ceramic fuses shown in Fig. 3, and the protectors electrode are retained only where necessary.

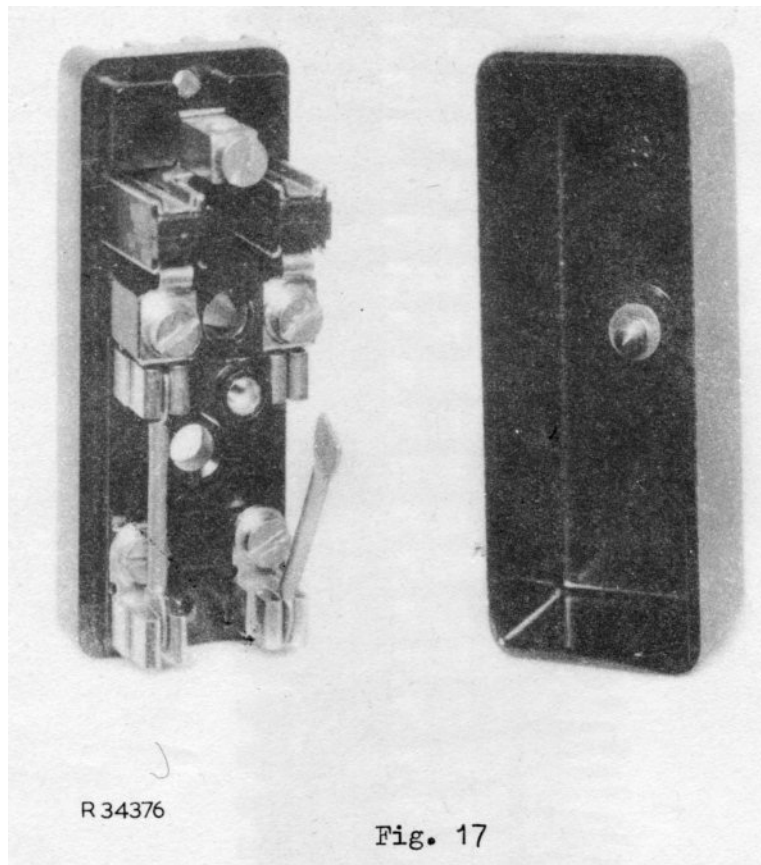

POLE-TOP PROTECTOR UNIT

When it is necessary to provide protection at the junction of overhead and underground wiring the electrode protectors are mounted either in a special terminal block which replaces the normal pole-top terminal block, or if less than six pairs require protection, in a special insert which fits inside the terminal insulator.

The pole-top protector unit caters for 15 pairs and contains contact springs for a protector electrode for every wire of every pair connected by the unit.

GAS DISCHARGE TUBES

The gas discharge tube is used as a protector on lines where there is a high risk of damage by induced voltages from power lines or lightning discharges. The tube, shown in Fig. 18,

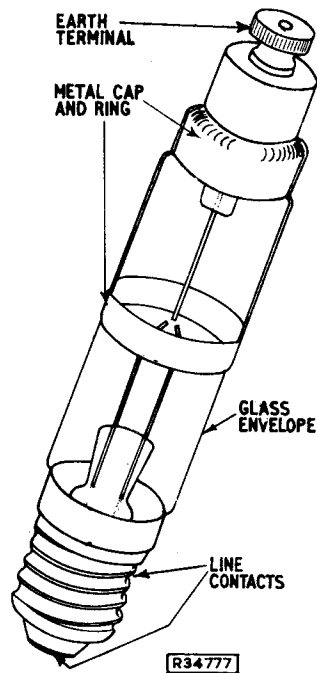

Fig. 18

consists of three tungsten electrodes in a glass envelope which contains a mixture of neon and argon gases at low pressure. Two of the electrodes, one for each wire of the line, are brought out to an Edison type screw cap; connexion to the wires is made through a threaded holder situated as near the line as possible. The third electrode is taken out to a terminal post to facilitate connexion to an earth electrode.

The arrangement of the electrodes within the envelope is shown clearly in Fig. 18. The electrodes are of tungsten wire having a diameter of 0.035 in and have square cut ends to reduce wear during arcing. A small amount of radium sulphide is introduced on to the glass seal of the earth electrode to partially ionise the gas

and so improve the speed of operation. The time delay in striking when 2000V r.m.s. is applied to the tube is of the order of 0.8 mS. The tube in use has a nominal current rating of 1 amp but is able to carry surge currents of the order of 10 amps, the operating voltages of the tube have been quoted earlier in the pamphlet.

LIMITATIONS OF PROTECTION

If a line is subjected to a direct lightning stroke or direct contact with a high voltage power line, the potential to earth is high enough and the energy dissipated great enough to destroy the protector fitting and the line plant. On overhead routes lightning conductors are provided on certain poles and physical barriers erected between the telephone lines and the power lines, but should a direct stroke or contact occur, there is no practical way of avoiding the destruction already mentioned.

In addition to the foregoing, the earlier scheme of protection outlined in this pamphlet has other limitations.

- (a) The current required to operate the earthing heat coil is in excess of that necessary to damage certain items of automatic telephone exchange apparatus.
- (b) The position of the protection is such that induced voltages pass through cable before reaching the protector. Experience has shown that this often leads to damage of the cable insulation at the junction between the open wires and the cable, or at the junction between different types of cable.

Protectors of normal design cannot be relied upon to discharge both lines of a circuit to earth simultaneously. Consequently it is possible for one line to discharge to earth via the subscriber's telephone and cause acoustic shock.

These limitations are well known, and the methods of protection are constantly under review to enable them to meet the changing techniques of line provision.

END